

K
Kawasaki

KZ750
Four

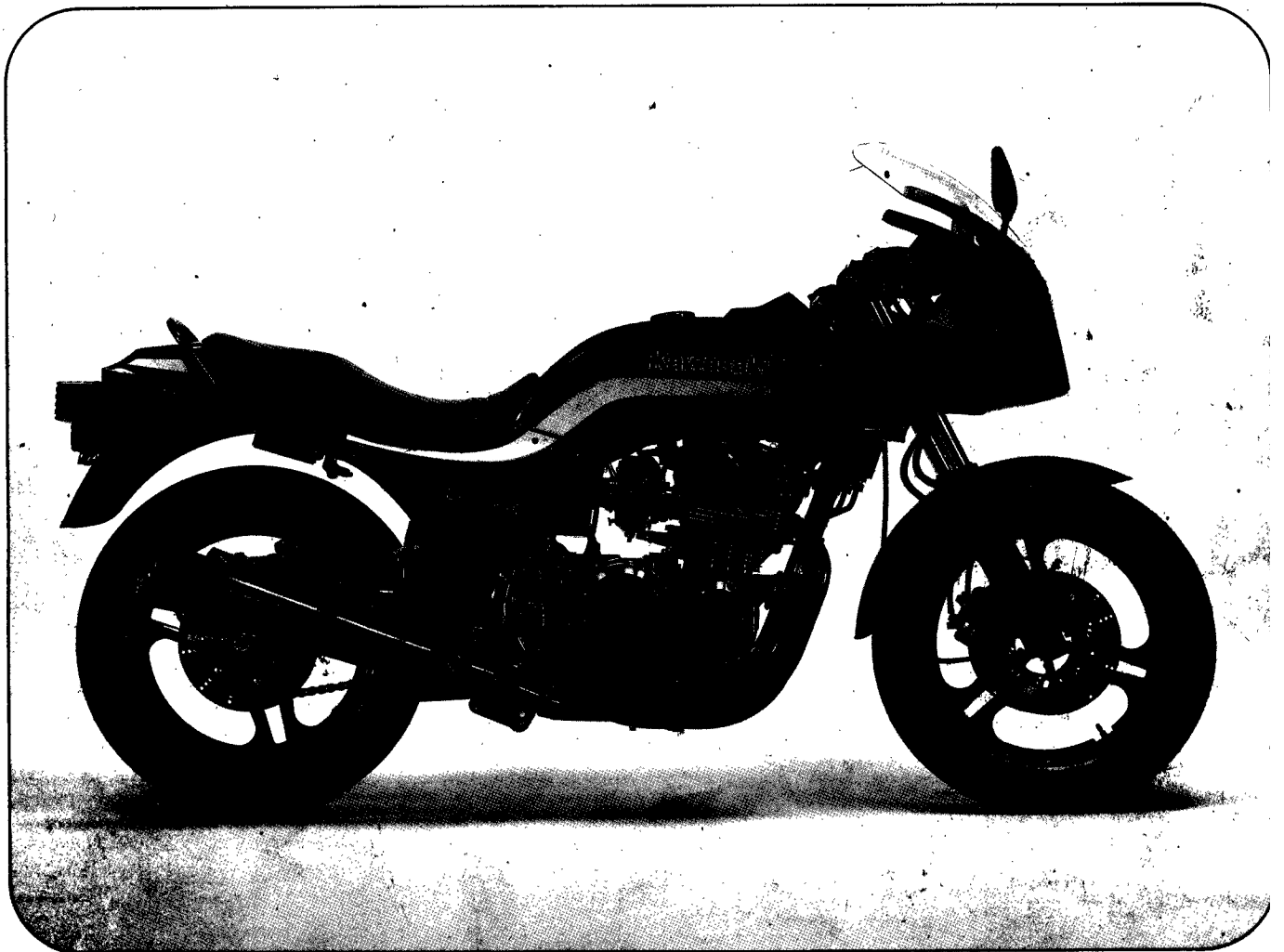

Motorcycle
Service Manual

Decimal Equivalents

INCH				MM INCH	INCH				MM INCH
$\frac{1}{64}$				1mm= .03937 inch	$\frac{33}{64}$				14mm= .55118 inch
	$\frac{1}{32}$.015625			$\frac{17}{32}$.515625	
$\frac{3}{64}$.03125	2mm= .07874 inch	$\frac{35}{64}$.53125	15mm= .59055 inch
		$\frac{1}{16}$.046875				$\frac{9}{16}$.546875	
$\frac{5}{64}$.0625	3mm= .11811 inch	$\frac{37}{64}$.5625	16mm= .62992 inch
	$\frac{3}{32}$.078125			$\frac{19}{32}$.578125	
$\frac{7}{64}$.09375	4mm= .15748 inch	$\frac{39}{64}$.59375	17mm= .66929 inch
		$\frac{1}{8}$.109375				$\frac{5}{8}$.609375	
$\frac{9}{64}$.125	5mm= .19685 inch				.625	18mm= .70866 inch
	$\frac{5}{32}$.140625			$\frac{41}{64}$.640625	
$\frac{11}{64}$.15625	6mm= .23622 inch		$\frac{21}{32}$.65625	19mm= .74803 inch
		$\frac{3}{16}$.171875			$\frac{43}{64}$.671875	
			.1875	7mm= .27559 inch			$\frac{11}{16}$.6875	20mm= .78740 inch
$\frac{13}{64}$.203125			$\frac{45}{64}$.703125	
	$\frac{7}{32}$.21875	8mm= .31496 inch		$\frac{23}{32}$.71875	21mm= .82677 inch
$\frac{15}{64}$.234375			$\frac{47}{64}$.734375	
		$\frac{1}{4}$.25	9mm= .35433 inch			$\frac{3}{4}$.75	22mm= .86614 inch
$\frac{17}{64}$.265625			$\frac{49}{64}$.765625	
	$\frac{9}{32}$.28125	10mm= .39370 inch		$\frac{25}{32}$.78125	23mm= .90551 inch
$\frac{19}{64}$.296875			$\frac{51}{64}$.796875	
		$\frac{5}{16}$.3125	11mm= .43307 inch			$\frac{13}{16}$.8125	24mm= .94488 inch
$\frac{21}{64}$.328125			$\frac{53}{64}$.828125	
	$\frac{11}{32}$.34375	12mm= .47244 inch		$\frac{27}{32}$.84375	25mm= .98425 inch
$\frac{23}{64}$.359375			$\frac{55}{64}$.859375	
		$\frac{3}{8}$.375	13mm= .51181 inch			$\frac{7}{8}$.875	1
$\frac{25}{64}$.390625			$\frac{57}{64}$.890625	
	$\frac{13}{32}$.40625			$\frac{29}{32}$.90625		
$\frac{27}{64}$.421875		$\frac{59}{64}$.921875		
		$\frac{7}{16}$.4375			$\frac{15}{16}$.9375		
$\frac{29}{64}$.453125		$\frac{61}{64}$.953125		
	$\frac{15}{32}$.46875			$\frac{31}{32}$.96875		
$\frac{31}{64}$.484375		$\frac{63}{64}$.984375		
		$\frac{1}{2}$.5				1		

Unit Conversion Table

cc	x	.0610	=	cu in
cc	x	.02816	=	oz (imp)
cc	x	.03381	=	oz (US)
cu in	x	16.39	=	cc
ft-lbs	x	12	=	in lbs
ft-lbs	x	.1383	=	kg-m
gal (imp)	x	4.546	=	litres
gal (imp)	x	1.201	=	gal (US)
gal (US)	x	3.7853	=	liters
gal (US)	x	.8326	=	gal (Imp)
grams	x	.03527	=	oz
in	x	25.40	=	mm
in lbs	x	.0833	=	ft-lbs
in lbs	x	.0115	=	kg-m
kg	x	2.2046	=	lbs
kg	x	35.274	=	oz
kg-m	x	7.233	=	ft-lbs
kg-m	x	86.796	=	in-lbs
kg/cm ²	x	14.22	=	lbs/in ²
km	x	.6214	=	mile
lb	x	.4536	=	kg
lb/in ²	x	.0703	=	kg/cm ²
litre	x	28.16	=	oz (imp)
litre	x	33.81	=	oz (US)
litre	x	.8799	=	qt (imp)
litre	x	1.0567	=	qt (US)
metre	x	3.281	=	ft
mile	x	1.6093	=	km
mm	x	.03937	=	in
oz (imp)	x	35.51	=	cc
oz (US)	x	29.57	=	cc
oz (weight)	x	28.35	=	grams
qt (imp)	x	1.1365	=	litre
qt (imp)	x	1.201	=	qt (US)
qt (US)	x	.9463	=	litre
qt (US)	x	.8326	=	qt (imp)
kg/cm ²	x	98.07	=	kPa
lbs/in ²	x	6.896	=	kPa
kPa	x	.1450	=	lbs/in ²

$$^{\circ}\text{C} \rightarrow ^{\circ}\text{F}: \frac{9(^{\circ}\text{C} + 40)}{5} - 40 = ^{\circ}\text{F}$$

$$^{\circ}\text{F} \rightarrow ^{\circ}\text{C}: \frac{5(^{\circ}\text{F} + 40)}{9} - 40 = ^{\circ}\text{C}$$

List of Abbreviations

ABDC	after bottom dead center
ATDC	after top dead center
BBDC	before bottom dead center
BDC	bottom dead center
BTDC	before top dead center
cc	cubic centimeters
cu in	cubic inches
ft	foot, feet
ft-lbs	foot-pounds
gal	gallon, gallons
hp	horsepower
in	inch, inches
in-lb	inch-pounds
kg	kilogram, kilograms
kg/cm ²	kilograms per square centimeter
kg-m	kilogram meters
km	kilometer
kph	kilometers per hour
lb, lbs	pound, pounds
lbs/in ²	pounds per square inch
ltr	liter, litre
m	meter, meters
mi	mile, miles
mm	millimeters
mph	miles per hour
oz	ounce, ounces
psi	pounds per square inch
qt	quart, quarts
rpm	revolutions per minute
sec	second, seconds
SS	standing start
TDC	top dead center
"	inch, inches
r/min	revolutions per minute
ℓ	liter, litre
kPa	kilo-Pascals



KZ750
Four

Motorcycle
Service Manual

Foreword

This manual is designed primarily for use by motorcycle mechanics in a properly equipped shop, although it contains enough detail and basic information to make it useful to the motorcycle user who desires to carry out his own basic maintenance and repair work. Since a certain basic knowledge of mechanics, the proper use of tools, and workshop procedures must be understood in order to carry out maintenance and repair satisfactorily; the adjustments, maintenance, and repair should be carried out only by qualified mechanics whenever the owner has insufficient experience, or has doubts as to his ability to do the work, so that the motorcycle can be operated safely.

In order to perform the work efficiently and to avoid costly mistakes, the mechanic should read the text, thoroughly familiarizing himself with the procedures before starting work, and then do the work carefully in a clean area. Whenever special tools or equipment is specified, makeshift tools or equipment should not be used. Precision measurements can only be made if the proper instruments are used, and the use of substitute tools may adversely affect safe operation of the motorcycle.

Whenever you see the symbols shown below, heed their instructions! Always follow safe operating and maintenance practices.

WARNING

This warning symbol identifies special instructions or procedures which, if not correctly followed, could result in personal injury, or loss of life.

CAUTION

This caution symbol identifies special instructions or procedures which, if not strictly observed, could result in damage to, or destruction of equipment.

“NOTE” indicates points of particular interest for more efficient and convenient operation.

This manual is divided into the following sections:

(1) Adjustment

The adjustment section gives the procedure for all adjustments which may become necessary periodically and which do not involve major disassembly.

(2) Disassembly

This section shows the best method for the removal, disassembly, assembly, and installation which are necessary for maintenance and repair. Do not disassemble parts further than explained in this manual. For spare parts, refer to the Parts Catalog. Since assembly and installation are usually the reverse of disassembly and removal, assembly and installation are not explained in detail in most cases. Instead, assembly notes and installation notes are provided to explain special points.

In cases where removal procedure is readily apparent, such as for the seat, side stand, etc., no information are given in this section.

(3) Maintenance and Theory of Operation

The procedures for inspection and repair are described in detail in this section. An explanation on the structure and functioning of each of the major parts and assemblies is given to enable the mechanic to better understand what he is doing.

(4) Appendix

The appendix in the back of this manual contains miscellaneous information, including a special tool list and wiring diagram.

(5) Supplement

The maintenance and repair procedures, that are unique to later year units since the first publication of the Service Manual, are explained in this chapter per one year unit.

Since this Service Manual is based on the first production units of the KZ750-E1, -H1, there may be minor discrepancies between some vehicles and the illustrations and text in this manual. Major changes and additions pertaining to later year units will be explained in a supplement following the appendix or by a new edition.

QUICK REFERENCE GUIDE

To use, bend the manual back and match the desired section below against the black spot showing at the edge of these pages. 

Specifications

Adjustment

- Engine
- Chassis

Disassembly

- Introduction
- Engine (Installed)
- Engine (Removed)
- Chassis

Maintenance & Theory

- Engine
- Chassis
- Electrical

Troubleshooting

Appendix

Supplement



4 MODEL IDENTIFICATION

Model Identification

KZ750-E1

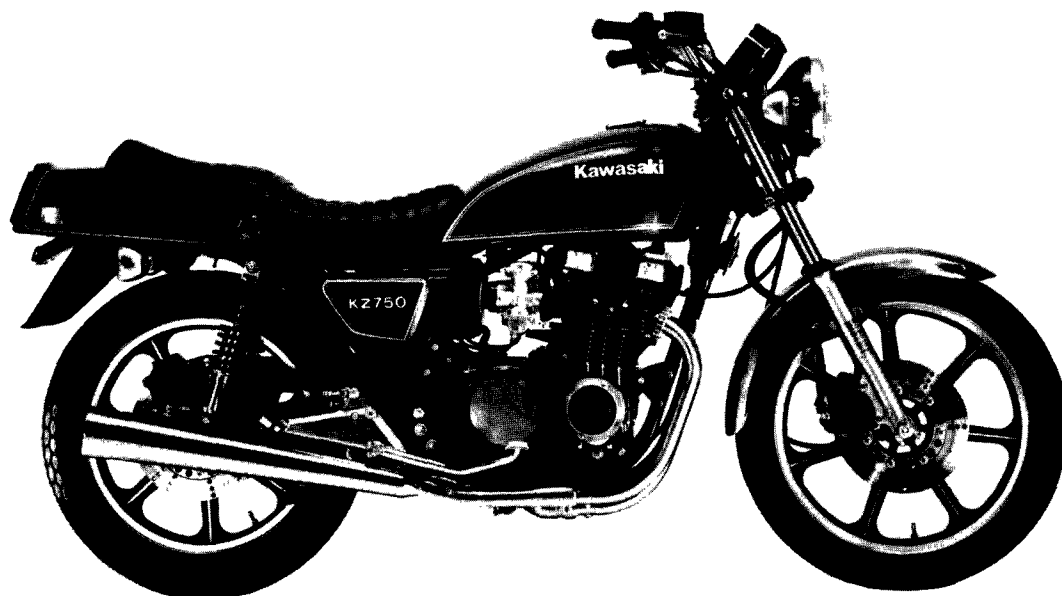

KZ750-H1



Specifications

Table of Contents

SPECIFICATIONS	6
ENGINE PERFORMANCE CURVES	8
RUNNING PERFORMANCE CURVES	9
PERIODIC MAINTENANCE CHART	10

6 SPECIFICATIONS

SPECIFICATIONS

		KZ750-E1		KZ750-H1
Dimensions				
Overall length		2,190 mm	Ⓔ 2,192 mm ⒸⓊ 2,130 mm	2,195 mm
Overall width		780 mm	ⒸⓊ 835 mm	810 mm
Overall height		1,135 mm		1,235 mm
Wheelbase		1,420 mm		1,450 mm
Road clearance		150 mm		155 mm
Dry weight		210 kg		211.3 kg
Fuel tank capacity		17.3 ℓ		12.4 ℓ
Performance				
Climbing ability		30°		*
Braking distance		12.5 m from 50 kph		*
Minimum turning radius		2.4 m		2.5 m
Engine				
Type		DOHC 4 cylinder, 4 stroke, air-cooled		*
Bore and stroke		66.0 x 54.0 mm		*
Displacement		738 cc		*
Compression ratio		9.0		*
Maximum horsepower		74 HP @9,000 rpm		*
Maximum torque		6.4 kg-m @7,500 rpm		*
Valve timing				
Inlet	Open	30° BTDC		*
	Close	60° ABDC		*
	Duration	270°		*
Exhaust	Open	60° BBDC		*
	Close	30° ATDC		*
	Duration	270°		*
Carburetors		Keihin CV34 x 4		*
Lubrication system		Forced lubrication (wet sump)		*
Engine oil	Type	SE class SAE 10W40, 10W50, 20W40, or 20W50		*
	Capacity	3.5 ℓ		*
Starting system		Electric starter		*
Ignition system		Battery and coil (transistorized ignition)		*
Cylinder numbering method		Left to right, 1-2-3-4		*
Firing order		1-2-4-3		*
Ignition timing (mechanically advanced)		From 10° BTDC @1,050 rpm to 40° BTDC @3,650 rpm		*
Spark plugs		NGK B8ES or ND W24ES-U ⒸⒺ NGK BR8ES or ND W24ESR-U		*
Transmission				
Transmission type		5-speed, constant mesh, return shift		*
Clutch type		Wet, multi disc		*
Driving system		Chain drive		*
Gear ratio:	1st	2.33 (35/15)		*
	2nd	1.63 (31/19)		*
	3rd	1.27 (28/22)		*
	4th	1.04 (26/25)		*

SPECIFICATIONS 7

	KZ750-E1	KZ750-H1
Primary reduction ratio	2.55 (27/23 x 63/29)	*
Final reduction ratio	2.54 (33/13)	2.46 (32/13)
Overall drive ratio	5.66 @top gear	5.49 @top gear
Electrical Equipment		
Maximum alternator output	238 VA @10,000 rpm	*
Battery	Furukawa FB12A-A (12V 12AH)	*
Headlight	Type Semi-sealed Ⓒ Ⓚ Sealed beam	Semi-sealed
	Bulb 12V 50/40W Ⓔ 12V 60/55W Ⓒ Ⓚ 12V 60/50W (quartz halogen light)	12V 60/55W (quartz halogen light)
Tail/Brake light(s)	12V 8/27W Ⓐ Ⓔ 12V 5/21W	12V 8/27W Ⓔ 12V 5/21W
City light	12V 3.4W Ⓔ 12V 4W	12V 4W
Turn signal lights	12V 23W Ⓔ 12V 21W	*
Turn signal/running position lights	12V 23/8W	*
Horn	12V 3A	*
Frame		
Type	Tubular, double cradle	*
Steering angle	39° to either side	*
Castor	27°	30°
Trail	108 mm	121 mm
Tire	Front Rear	* 130/90-16 67H Tubeless
	3.25H-19 4PR Tubeless 4.00H-18 4PR Tubeless	
Suspension type	Front Rear	* *
	Telescopic fork Swing arm	
Wheel travel	Front Rear	180 mm 100 mm
	160 mm 95 mm	
Front fork oil	Type Capacity (each fork)	* 280 cc
	SAE 10W 232 cc Ⓒ Ⓚ 248 cc	
Brakes		
Type	Front Rear	* *
	Dual disc brakes Single disc brake	
Effective disc diameter	Front Rear	* *
	226 mm 226 mm	

* : Same as left column

Ⓐ : Australian model

Ⓒ : Canadian model

Ⓔ : European model

Ⓚ : US model

Specifications subject to change without notice, and may not apply to every country.

8 SPECIFICATIONS

ENGINE PERFORMANCE CURVES

KZ750-E1, H1

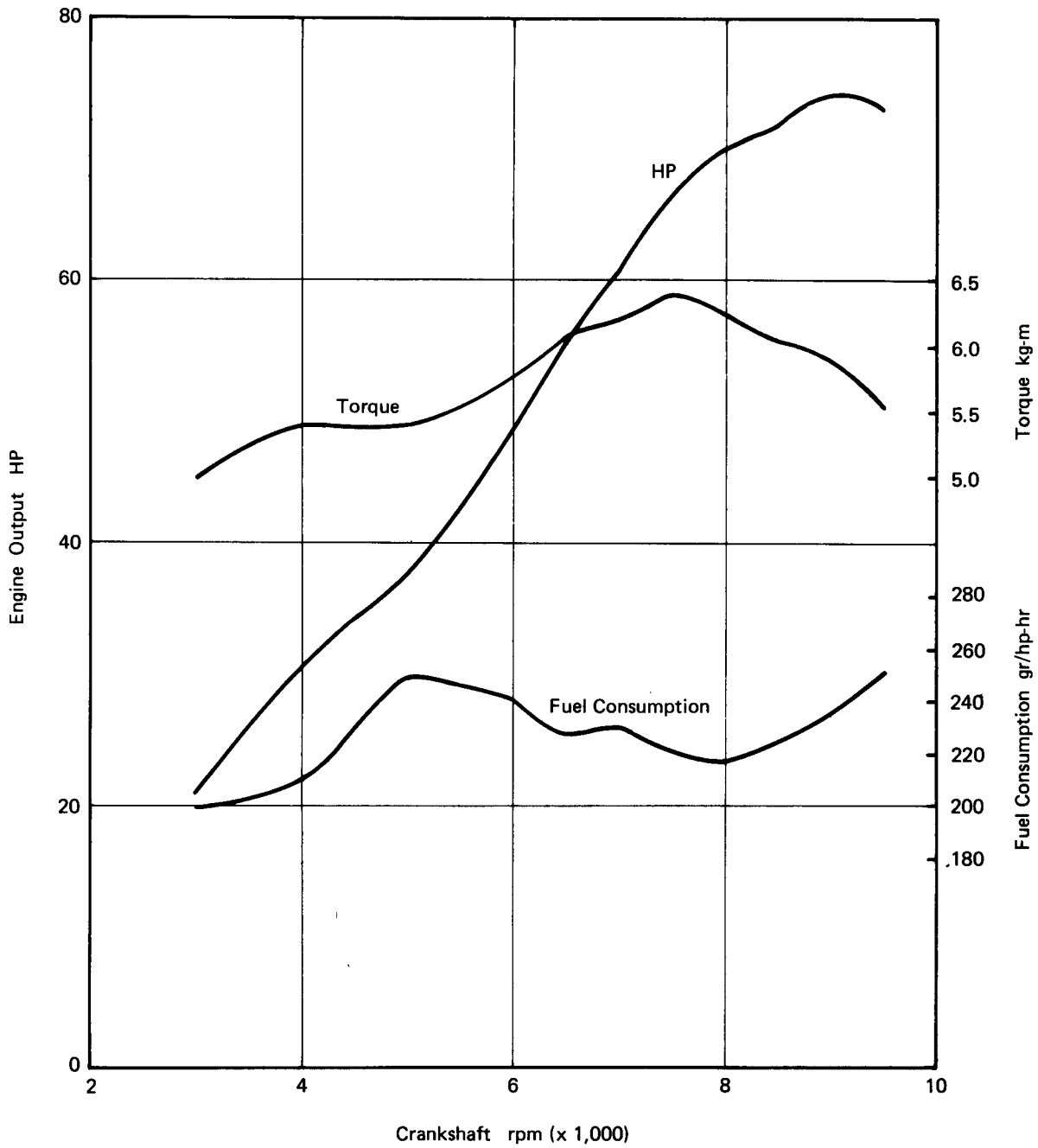

RUNNING PERFORMANCE CURVES

KZ750-E1

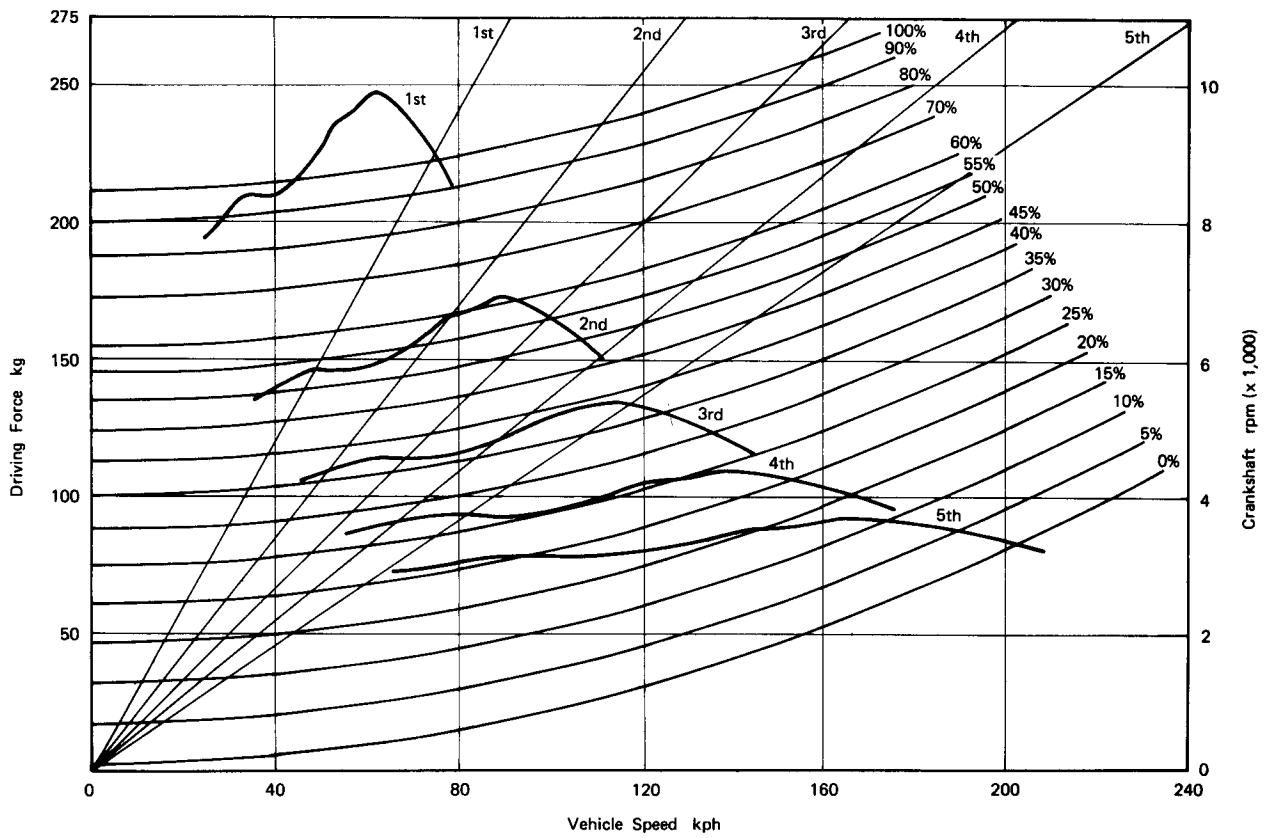

KZ750-H1

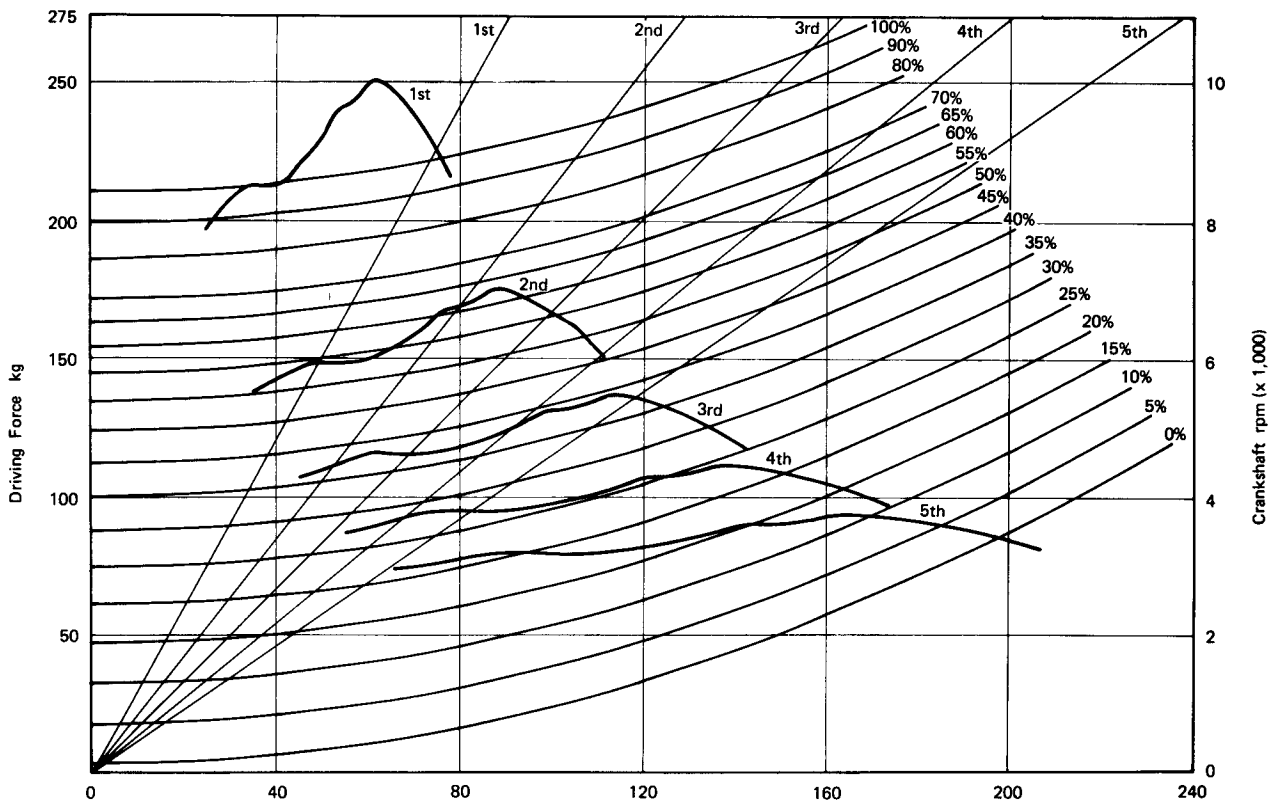

10 SPECIFICATIONS

PERIODIC MAINTENANCE CHART

The maintenance and adjustments must be done in accordance with this chart to keep the motorcycle in good running condition. The initial maintenance is vitally important and must not be neglected.

OPERATION	FREQUENCY	ODOMETER READING*							See Page
		800 km	5,000 km	10,000 km	15,000 km	20,000 km	25,000 km	30,000 km	
Battery electrolyte level – check †	Every month	•	•	•	•	•	•	•	218
Brake wear – check †			•	•	•	•	•	•	201~205
Brake fluid level – check †	month	•	•	•	•	•	•	•	207
Brake fluid – change	year			•		•		•	206
Clutch – adjust		•	•	•	•	•	•	•	17
Carburetors – adjust		•	•	•	•	•	•	•	15
Throttle cable – adjust		•	•	•	•	•	•	•	14
Steering play – check †		•	•	•	•	•	•	•	26
Drive chain wear – check †			•	•	•	•	•	•	198
Front fork – inspect/clean		•	•	•	•	•	•	•	211
Rear shock absorbers – inspect		•	•	•	•	•	•	•	214
Nuts, Bolts, Fasteners – check and torque		•		•		•		•	35~39
Spark plugs – clean and gap †		•	•	•	•	•	•	•	12
Valve clearance – check †		•	•	•	•	•	•	•	12
Air suction valves – check †			•	•	•	•	•	•	166
Air cleaner element – clean			•		•		•		148
Air cleaner element – replace	5 cleanings			•		•		•	148
Fuel system – clean		•	•	•	•	•	•	•	19
Tire tread wear – check †			•	•	•	•	•	•	193
Engine oil – change	year	•	•	•	•	•	•	•	18
Oil filter – replace		•		•		•		•	18
General lubrication – perform			•	•	•	•	•	•	29
Front fork oil – change				•		•		•	212
Timing advancer – lubricate				•		•		•	227
Swing arm – lubricate				•		•		•	215
Wheel bearings – grease	2 years					•			197
Speedometer gear housing – grease	2 years					•			197
Steering stem bearings – grease	2 years					•			209
Drive chain – lubricate	Every 300 km								198
Drive chain – adjust	Every 800 km								23

*For higher odometer readings, repeat at the frequency interval established here.

†Replace, add or adjust if necessary.

Adjustment—Engine

Table of Contents

SPARK PLUGS	12
VALVE CLEARANCE	12
THROTTLE CABLE	14
CARBURETORS	15
Idling Adjustment (on US model)	15
Idling Adjustment (other than US model)	15
Carburetor Synchronization	16
CLUTCH	17
ENGINE OIL	18
Oil Level Inspection	19
Oil and Oil Filter Change	19
FUEL SYSTEM	19
SHIFT PEDAL LINKAGE	19

12 ADJUSTMENT—ENGINE

SPARK PLUGS

Neglecting the spark plug eventually leads to difficult starting and poor performance. If the spark plug is used for a long period, the electrodes gradually burn away and carbon builds up along the insulator. In accordance with the Periodic Maintenance Chart (Pg. 10), the plug should be removed for inspection, cleaning and to reset the gap.

- Remove the spark plugs using a spark plug wrench.
- Clean the spark plug preferably in a sand-blasting device, and then clean off any abrasive particles. The plug may also be cleaned using a high flash-point solvent and a wire brush or other suitable tool. If the spark plug electrodes are corroded or damaged, or if the insulator is cracked, replace the plug. Use the standard plug or its equivalent.
- Measure the gap with a wire-type thickness gauge. If the gap is incorrect carefully bend the outer electrode, with a suitable tool to obtain the correct gap.

Spark Plug Gap

B1

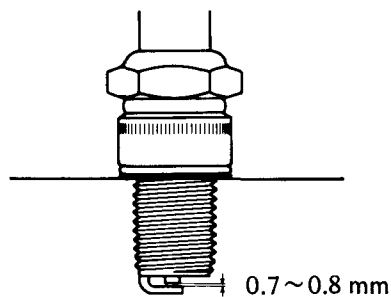

CAUTION For cold weather low speed riding, a hotter spark plug (NGK B7ES or BR7ES, ND W22ES-U or W22ESR-U) may be used for quicker warm-ups and more efficient engine operation. However, for normal temperatures and/or high speed use, the standard spark plug (NGK B8ES or BR8ES, ND W24ES-U or W24ESR-U) must be used to prevent engine damage.

Table B1 Spark Plug

Riding Condition	Normal	Cold weather [below 10°C (50°F)] low speed
Type	NGK B8ES ND W24ES-U Ⓜ NGK BR8ES ND W24ESR-U	NGK B7ES ND W22ES-U Ⓜ NGK BR7ES ND W22ESR-U
Gap	0.7 ~ 0.8 mm	
Tightening Torque	2.8 kg-m (20 ft-lbs)	

- Tighten the spark plugs in the cylinder head to specified torque.

VALVE CLEARANCE

Valve and valve seat wear decreases valve clearance, upsetting valve timing. If valve clearance is left unadjusted, the wear will eventually cause the valves to remain partly open, which lowers performance, burns the valves and valve seats, and may cause serious engine damage.

Valve clearance for each valve should be checked and, if incorrect, adjusted in accordance with the Periodic Maintenance Chart (Pg. 10) and any time that clearance may have been affected by disassembly.

When carrying out adjustment, be careful to adjust within the specified clearance. Adjusting to a larger value will both disturb valve timing and cause engine noise.

NOTE: Valve clearance must be checked when the engine is cold.

To check the valve clearance:

- Remove the fuel tank (Pg. 43).
- Remove the ignition coils (Pg. 51).
- Remove the cylinder head cover (See the Camshaft Removal: Pg. 53).
- Check the tightening torque of the camshaft cap bolts [1.2 kg-m (104 in-lbs)].
- Remove the pick-up coil cover.
- Using a 17 mm wrench on the crankshaft, turn the crankshaft so that the "1 4" T mark on the timing advancer is aligned with the timing mark.

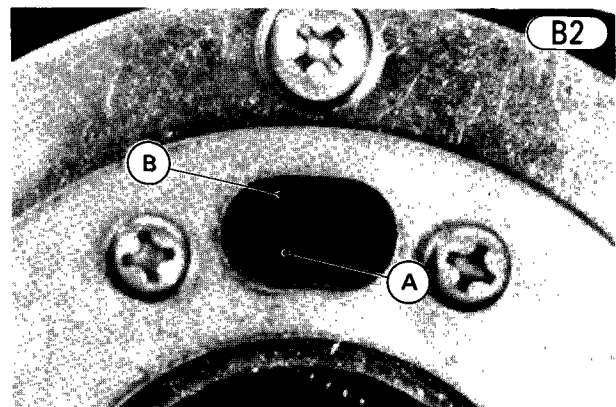

B2

14 ADJUSTMENT—ENGINE

- For two inlet valves (#1 and #3, or #2 and #4) at a time, measure the clearance between the cam and the valve lifter. The correct clearance is 0.08 ~ 0.18 mm for both inlet and exhaust valves.

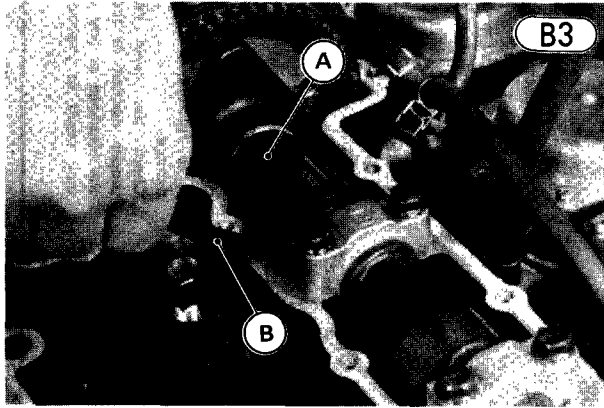

A. Inlet Camshaft B. Thickness Gauge

- Turn the crankshaft a half turn until the "2 3" T mark is aligned with the timing mark, and measure the clearance of two exhaust valves (#1 and #3, or #2 and #4).

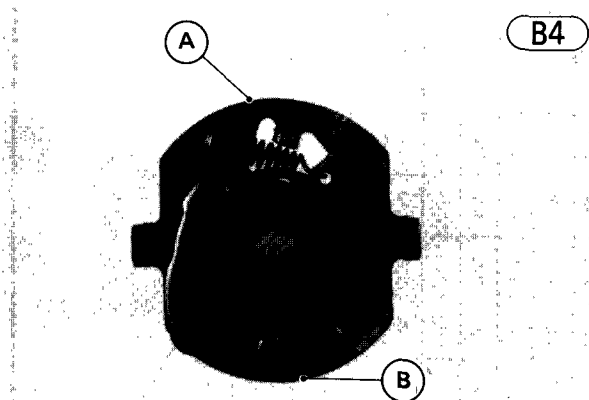

A. "1 4" T Mark B. "2 3" T Mark

- Turning the crankshaft another a half turn and then another a half turn to measure the clearance for the remaining valves.
 - If the valve clearance is incorrect, continue the following procedures to replace the present shim with a new shim, which will give the proper clearance.
- NOTE:** If there is no clearance between the valve lifter and cam, select a shim which is several sizes smaller and then remeasure the clearance once it is installed.

To adjust the valve clearance:

- Remove the camshaft (Pg. 53).
- Being careful not to damage the valve lifter, pull off

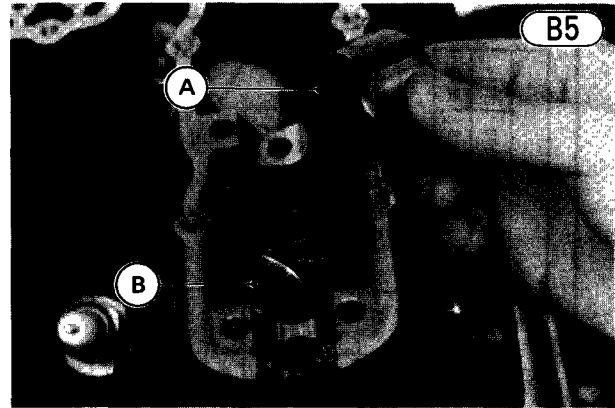

A. Valve Lifter B. Shim

- Check the present shim thickness (shim size) which is printed on the shim surface, and referring to the Valve Adjustment Chart (Pg. 13), select a new shim which brings valve clearance within the specified limits. Shims are available in sizes from 2.0~3.2 mm, in increments of 0.05 mm.

- Insert the new shim on the valve spring retainer.

- CAUTION**
1. Do not put shim stock under the shim. This may cause the shim to pop out at high rpm, causing extensive engine damage.
 2. Do not grind the shim. This may cause it to fracture, causing extension engine damage.

NOTE: If the smallest shim does not sufficiently increase clearance, the valve seat is probably worn. In this case, repair the valve seat (Pg. 163), and check the valve stem installed height (Pg. 164).

- Install the camshaft (Pg. 54), remeasure the valve clearance that was adjusted, and readjust if necessary.

Valve Location

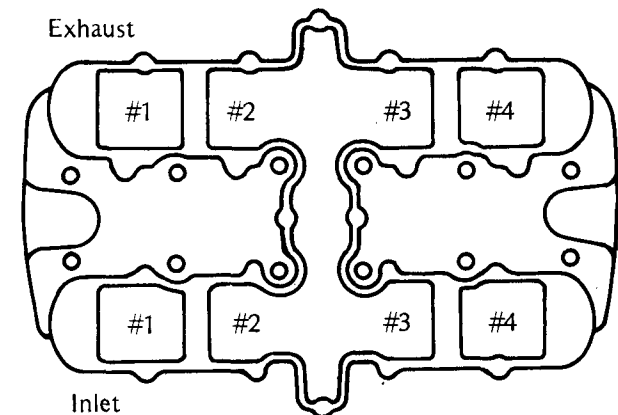

THROTTLE CABLE

The throttle cable controls the carburetor butterfly valves. Excessive play in the throttle grip will cause a delay in throttle response, especially at low rpm. Also, the butterfly valves may not open fully at full throttle. On the other hand, if the cable is too tight, the throttle will be hard to control, and the idle speed will be erratic.

To check and adjust the throttle cable:

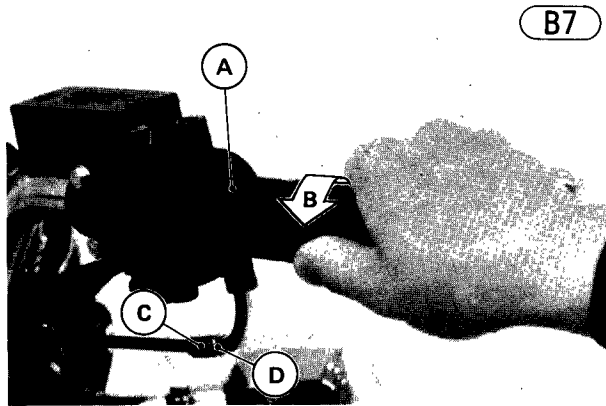

A. Throttle Grip
B. 2~3 mm play
C. Adjusting Nut
D. Locknut

●If not, loosen the locknut, and turn the adjusting nut until 2~3 mm of throttle grip play is obtained. Tighten the locknut.

NOTE: If the throttle cable cannot be adjusted by using the cable adjusting nut at the upper end of the throttle cable, use the cable adjuster at the lower end of the throttle cable. Do not forget to securely tighten the adjuster locknut.

CARBURETORS

For internal carburetor maintenance and replacement of parts, see the maintenance section (Pg. 150) of this manual. The following procedure covers the idling adjustment, which should be inspected during periodic maintenance or whenever the idling setting has been disturbed. This procedure also includes the necessary steps for obtaining proper carburetor synchronization.

When the idle speed is too low, the engine may stall; when the idle speed is too high, the fuel consumption becomes excessive, and the resulting lack of engine braking may make the motorcycle difficult to control. Poor carburetor synchronization will cause unstable idling, sluggish throttle response, the reduced engine power and performance.

The following procedure consists of two parts: idling adjustment and carburetor synchronization.

Idling Adjustment

- Start the engine, and warm it up thoroughly.
- Adjust the idle speed to 1,000~1,100 rpm by turning

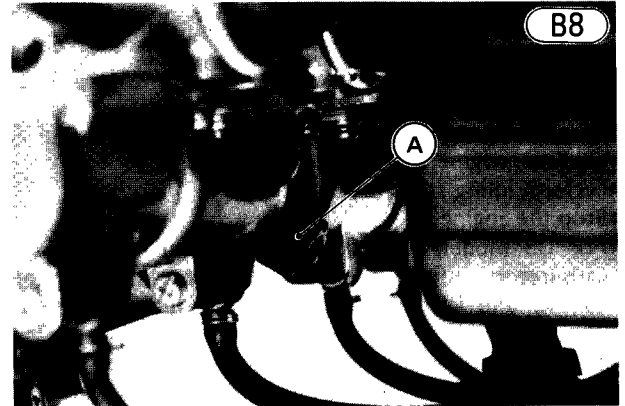

A. Idle Adjusting Screw

●Open and close the throttle a few times to make sure that the idle speed does not change. Readjust if necessary.

NOTE: With the engine idling, turn the handlebar to either side. If handlebar movement changes idle speed, the throttle cable may be improperly adjusted or incorrectly routed, or they may be damaged.

WARNING Operation with improperly adjusted, incorrectly routed, or damaged cable could result in an unsafe riding condition.

NOTE: If proper idle speed cannot be obtained by this adjustment above, first check the following and correct as necessary.

- Engine Oil
- Spark Plugs
- Throttle Cable
- Cylinder Compression
- Air Cleaner Element
- Air Cleaner Duct and Carburetor Holder Leakage
- Camshaft Chain
- Valve Clearance
- Kawasaki Clean Air System
- Carburetor Function Checks

Carburetor Synchronization

Fine adjustment of carburetor synchronization, necessary for smooth engine operation, requires the use of vacuum gauges. A difference between left two cylinders and right two cylinders might be found from exhaust noise and exhaust pressure; but to synchronize each carburetor, using vacuum gauges is essential.

- NOTES:**
1. During carburetor synchronization, the fuel tank will be removed. In most cases, it will be necessary to temporarily replace the standard fuel lines with lines long enough to reach the fuel tank while it is located on your workbench.
 2. If fuel is supplied to the carburetors from another optional tank, the vacuum hose for the automatic fuel tap will be open and extra air drawn into the carburetor bore through the vacuum hose. This results in improper carburetor synchronization. To prevent this, plug the open end of the vacuum hose during carburetor synchronization so that no extra air can be

16 ADJUSTMENT—ENGINE

WARNING Use extreme caution when working with gasoline, open fuel lines, etc. to avoid a fire or explosion.

To check the carburetor synchronization:

- Start the engine, and warm it up thoroughly.
- Perform idling adjustment.
- Stop the engine.
- For US model, pull off the rubber cap from the #3 carburetor, and pull off the vacuum hoses (3) from the #1, #2, and #4 carburetors sliding the hose clamps out of position.
- Except for US model, pull off the rubber caps (3) from the #1, #3, and #4 carburetors, and pull off the vacuum hose from the #2 carburetor sliding the hose clamp out of position.

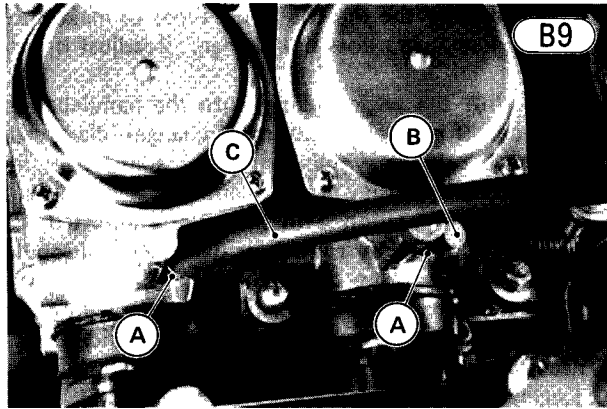

A. Vacuum Gauge Attachment **C. Vacuum Hose**
B. Rubber Cap

- Attach the vacuum gauges (special tool) fitting the gauge hoses to the vacuum gauge attachments.

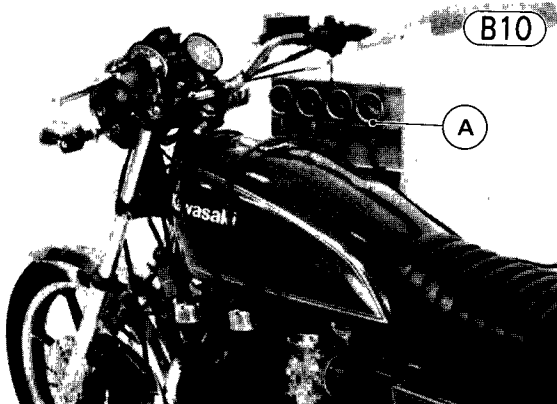

A. Vacuum Gauge Set (57001-127)

- Turn the fuel tap lever to the "PRI" position.
- With the engine running at idle speed, close the vacuum gauge damper valves until gauge needle flutter is less than 3 cmHg. Note the gauge reading.

Table B3 Engine Vacuum

Engine Vacuum	22 cmHg
Difference between ..	less than 2cmHg

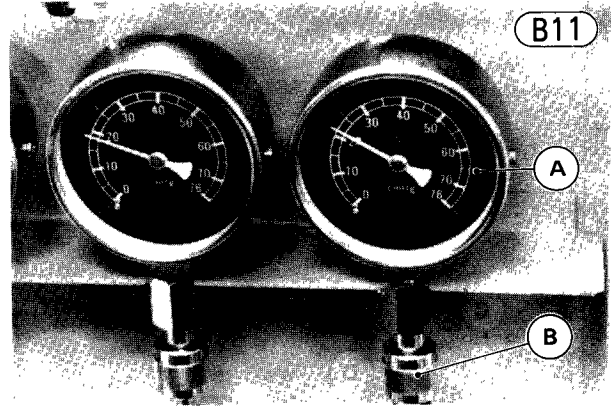

A. Vacuum Gauge **B. Damper Valve**

- If the difference in vacuum readings between any two cylinders is greater than the specified value, synchronize the carburetors according to the following procedure.

To synchronize the carburetors:

- Remove the fuel tank (Pg. 43), and supply fuel for carburetors by some means during adjustment.
- With the engine running at idle speed, loosen the locknut and alter the balance adjusting screw position using the balance adjuster (special tool) to obtain a difference in readings which is less than the specified value. Tighten the locknut.

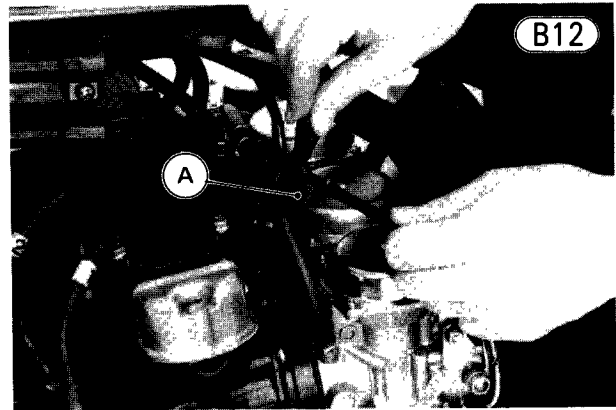

A. Balance Adjuster (57001-351)

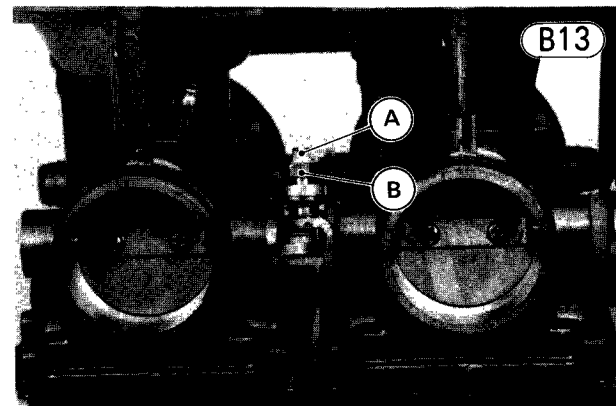

- Perform idling adjustment again.
- Open the throttle grip and let it snap shut a few times. Make sure the vacuum readings stay within the specified vacuum reading. If they do not, repeat the last two steps.
- If any gauge reads 5cmHg or more below the specified pressure after synchronizing the carburetors; check the points listed in the end of the idling adjustment.
- After the carburetors are properly synchronized, tighten the locknuts without changing the positions of the adjusting screws.
- Detach the vacuum gauges, and install the vacuum plugs (1 or 3). Connect the vacuum hoses (1 or 3) to the fitting(s). Slide the hose clamp(s) back into place.
- Install the fuel tank (Pg. 43).

CLUTCH

Stretching of the clutch cable causes the clutch lever to develop excessive play. Too much play will prevent complete disengagement and may result in shifting difficulty and possible clutch and transmission damage. Most of the play must be adjusted out, but a small amount must remain so that the clutch release lever will function properly.

Clutch plate wear also causes the clutch to go out of adjustment. This wear causes the play between the push rod and the adjusting screw to gradually diminish until the push rod touches the adjusting screw. When this play is lost, the clutch will not engage fully, causing the clutch to slip.

NOTE: Even though the proper amount of play exists at the clutch lever, clutch lever play alone cannot be used to determine whether or not the clutch requires adjustment.

The adjustment procedure which follows compensates for both cable stretch and plate wear.

WARNING To avoid a serious burn, never touch a hot engine or exhaust pipe during clutch adjustment.

To adjust the clutch:

- Turn in fully the locknut and adjusting nut at the center of the clutch cable to give the cable plenty of play.

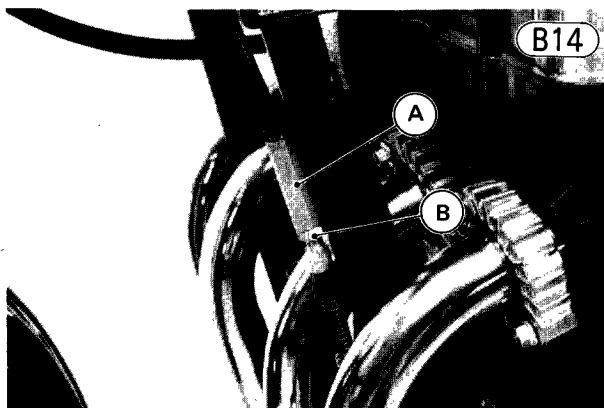

B14

- Loosen the knurled locknut at the clutch lever just enough so that the adjuster will turn freely, and then turn the adjuster to make a 5 ~ 6 mm gap between the adjuster and locknut.

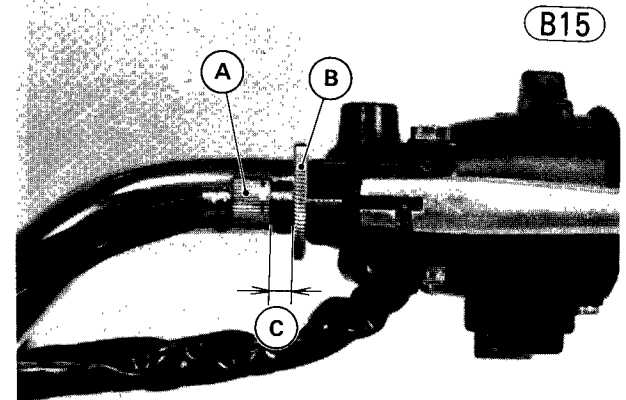

B15

A. Adjuster C. 5~6 mm
B. Knurled Locknut

- Remove the clutch adjusting cover.
- Loosen the locknut, and back out the clutch adjusting screw a couple of turns.

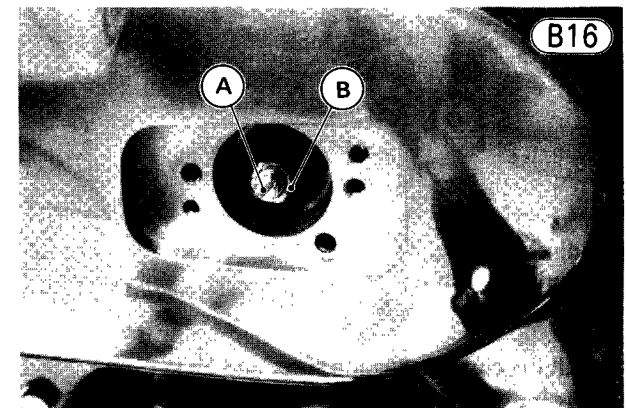

B16

A. Adjusting Screw B. Locknut

- Turn the adjusting screw in until it becomes hard to turn. This is the point where the clutch is just starting to release.
- Back out the adjusting screw 1/2 turn from that point, and tighten the locknut without changing the adjusting screw position.
- Take up all the cable play with the adjusting nut at the center of the cable, and then tighten the locknut.
- Make sure the lower end of the clutch outer cable is properly fitted into the cable bracket hole in the engine sprocket cover.

WARNING If the cable is not fully seated in the cable bracket hole in the engine sprocket cover, it could slip into place later and the clutch would not

18 ADJUSTMENT—ENGINE

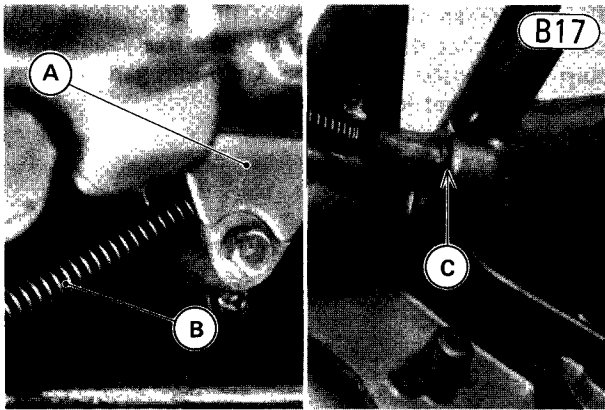

A. Engine Sprocket Cover
B. Clutch Cable

C. Cable Bracket Hole

- Turn the adjuster at the clutch lever so that the clutch lever will have 2~3 mm of play as shown in the figure, and tighten the knurled locknut.

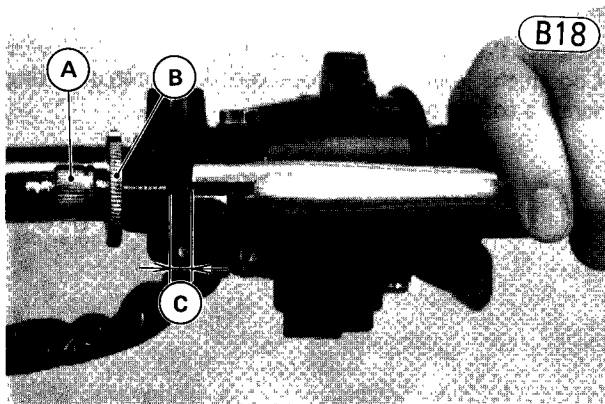

A. Adjuster
B. Knurled Locknut

C. 2~3 mm

- Install the clutch adjusting cover and gasket.
- Start the engine and check that the clutch has no slippage and that it releases properly.

ENGINE OIL

In order for the engine, transmission, and clutch to function properly, always maintain the engine oil at the proper level. Change the oil and replace the oil filter in accordance with the Periodic Maintenance Chart (Pg. 10).

WARNING Motorcycle operation with insufficient, deteriorated, or contaminated engine oil will cause accelerated wear and may result in engine or

Oil Level Inspection

- Set the motorcycle up on its center stand.
- If the oil has just been changed, start the engine and run it for several minutes at idle. This fills the oil filter with oil. Then wait several minutes until the oil settles.

CAUTION Run the engine at idle at least until the oil pressure light turns off. Racing the engine before the oil reaches every part can cause engine damage and seizure.

- If the motorcycle has just been used, wait several minutes for all the oil to drain down.
- Check the engine oil level through the oil level gauge in the lower right side of the engine. With the motorcycle held level or on the center stand, the oil level should come up between the lines next to the gauge.

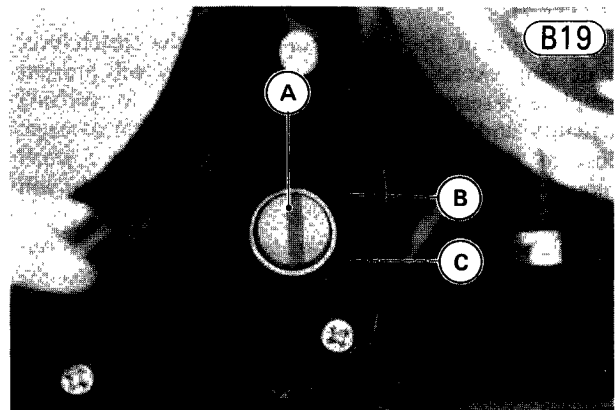

A. Engine Oil Level Gauge
B. Upper Level Line

C. Lower Level Line

- If the oil level is too high, remove the excess oil, using a syringe or some other suitable device.
- If the amount of oil is insufficient, add oil through the oil filler opening. Use the same type and brand of oil that already is in the engine.

CAUTION If the engine oil level gets extremely low or if the oil pump or oil passages clog up or otherwise do not function properly, the red oil pressure warning light in the switch panel will light. If this light stays on when the engine speed is above 1,200 rpm, stop the engine immediately and find the cause.

WARNING If the engine is run without oil, it will be severely damaged. In addition, the engine may suddenly seize, locking the rear wheel and causing an accident if the clutch lever is not pulled in fast enough.

Oil and Oil Filter Change

- Warm up the engine thoroughly, and then stop the engine.
- Set the motorcycle up on its center stand, place an oil pan beneath the engine, and remove the engine

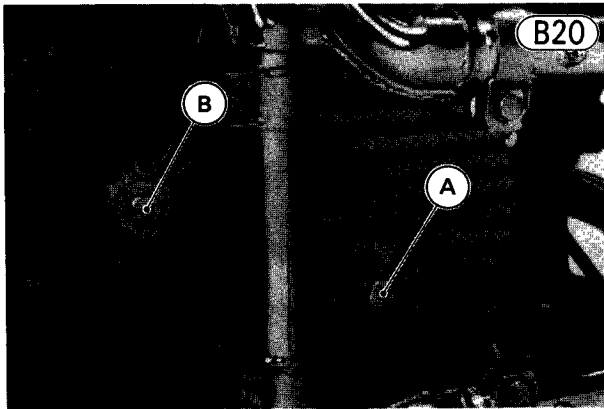

A. Engine Drain Plug B. Oil Filter Mounting Bolt

- If the oil filter is to be changed, remove the filter mounting bolt and drop out the oil filter.
- Replace the oil filter with a new one. Check that it is properly assembled.

NOTE: Check for O ring damage. If necessary, replace them with new ones.

- Install the oil filter, tightening its bolt to 2.0 kg-m (14.5 ft-lbs) of torque.
- After the oil has completely drained out, install the engine drain plug. Proper torque for the drain plug is 3.8 kg-m (27 ft-lbs).
- Fill the engine up to the upper level with a quality motor oil specified in the table.

NOTE: After the engine has been run and then stopped for a few minutes, the oil level should come to between the upper and lower marks.

Table B4 Engine Oil

Grade	Viscosity	Filling Engine Oil Capacity	
		When filter is not changed	When filter is changed
SE class	SAE 10W40	3.0 liters	3.5 liters
	10W50		
	20W40	3.0 liters	3.5 liters
	20W50		

FUEL SYSTEM

Water anywhere in the fuel system can cause starting difficulty, poor running, and lack of power. Clean out the fuel system as follows.

WARNING

1. Clean the fuel system in a well-ventilated area, and take ample care that there are no sparks or flame anywhere near the

2. Never clean out the fuel system when the engine is still warm.
3. Wipe any fuel off the engine before starting it.
 - Pull the overflow tubes off the bottom of the air cleaner housing, and run the tubes to a container.
 - Turn the fuel tap lever to the "PRI" position.
 - Loosen the drain screws, and drain the fuel in the fuel tank and float bowls through the overflow tubes. Tighten the drain screws.

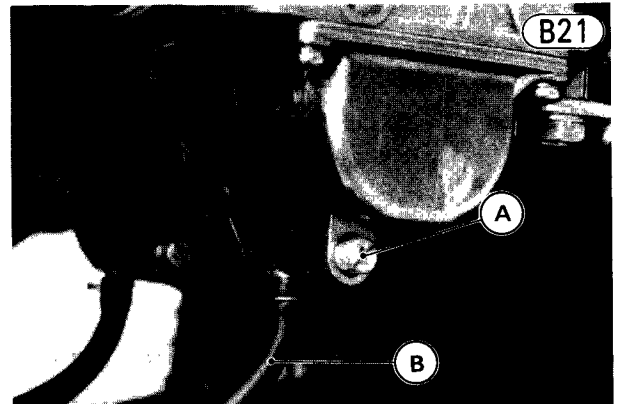

A. Drain Screw B. Overflow Tube

- If any dirt comes out, clean the following parts in according to the procedure in the Maintenance Section.
 - Fuel Tank (Pg. 149)
 - Fuel Tap (Pg. 149)
 - Carburetors (Pg. 150)
- Run the overflow tubes to each fitting on the air cleaner housing.

SHIFT PEDAL LINKAGE

For the motorcycle which has the shift pedal linkage, to make the shift pedal function most effectively, the shift pedal linkage should be at 90° angles. Improper angles of the shift pedal linkage may cause inaccurate shift operation.

Inspection

- Check that the shift pedal linkage angles are at 90°.
- Check that the shift pedal end matches the level of the

20 ADJUSTMENT—ENGINE

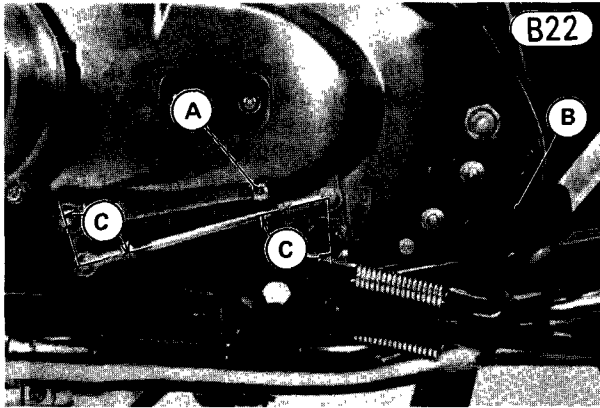

A. Shift Pedal B. Left Footpeg C. 90°

- If the pedal is found improperly adjusted by either one of the above checks, adjust the shift pedal.

Adjustment

- In case of the linkage angle at the shift lever is improper, first remove the lever, and then remount it at a new position on the shift shaft for the proper angle.
- Tighten the lever bolt.
- Loosen the locknuts of the shift linkage rod.
- Turn the rod to make the proper pedal position, and tighten the locknuts.

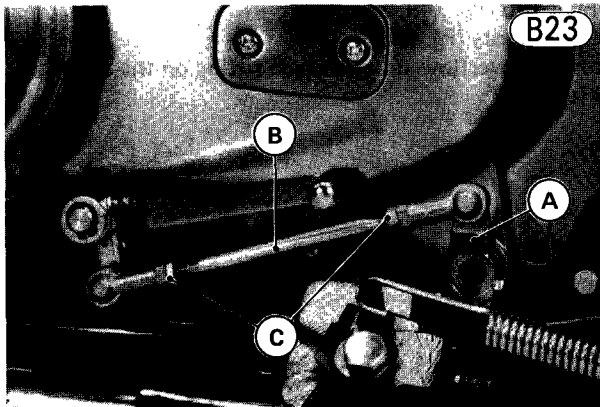

A. Shift Lever C. Locknuts
B. Shift Linkage Rod

Adjustment—Chassis

Table of Contents

FRONT FORK	22
REAR SHOCK ABSORBERS	22
Spring Adjustment	22
Damper Adjustment	23
FRONT AND REAR SUSPENSION SETTING	23
DRIVE CHAIN	23
BRAKES	24
Front Brake	24
Rear Brake	24
BRAKE LIGHT SWITCH	25
STEERING	26
WHEEL BALANCE	27
HEADLIGHT	28
Horizontal Adjustment	28
Vertical Adjustment	28
GENERAL LUBRICATION	29

22 ADJUSTMENT—CHASSIS

FRONT FORK

The front fork can be adjusted to any air pressure within the usable range to suit various riding and load conditions. They can be adjusted to lower air pressure for cruising on smooth roads, but should be adjusted to higher pressure to high speed riding, or riding on bad roads. Before making any adjustments, however, read the procedures in this chapter.

To check the front fork air pressure:

- Put the motorcycle up on its center stand.
- Raise the front wheel off the ground by using a jack under the engine. All weight must be off the front wheel.
- Remove the air valve cap, and check the air pressure with the air pressure gauge (special tool).



A. Air Pressure Gauge (52005-1003)
B. Air Valve

- NOTES:** 1. Check the air pressure when the fork legs are cold.
2. Do not use tire gauges for checking air pressure. They may not indicate the correct air pressure because of air leaks that occur when the gauge is applied to the valve.

To adjust the front fork air pressure:

- Inject air through the valve with a pump to adjust the pressure, but do not exceed 2.5 kg/cm² (36 psi, 250 kPa).

- NOTES:** 1. A normal tire pump can be used.
2. Adjust the air pressure to suit various riding conditions referring to the Front and Rear Suspension Setting (Pg. 23).

Table C1 Air Pressure

	Standard kg/cm ² (psi, kPa)	Usable Range kg/cm ² (psi, kPa)
KZ750-E	0.7 (10, 70)	0.6~0.9 (8.5~13, 60~90)
KZ750-H	0.6 (8.5, 60)	0.5~1.0

CAUTION

1. Try to set the air pressure of the right and left fork legs as equally as possible. The difference in air pressure between the right and left fork legs must be within 0.1 kg/cm² (1.4 psi, 10 kPa).
2. Inject air little by little so that air pressure does not rise rapidly. Air pressure exceeding 2.5 kg/cm² (36 psi, 250 kPa) may damage the oil seals.

WARNING

1. Be sure to adjust the air pressure within the usable range. Front fork adjusted too low or too high adversely affect handling and stability and could lead to accident and injury.
2. Only air or nitrogen gas can be used. Never inject oxygen or any other kind of gas. Other gases could produce an explosion.
3. Do not incinerate the front fork.

REAR SHOCK ABSORBERS

The rear shock absorbers can be adjusted by changing the spring force and damping force to suit various riding and loading conditions. The spring force and damping force can be left soft for average riding. But they should be adjusted harder for high speed riding, or riding with a passenger.

Before making any adjustments, however, read the following procedures:

Spring Adjustment

The spring adjusting sleeve on each rear shock absorber has 5 positions so that the spring can be adjusted for different road and loading conditions.

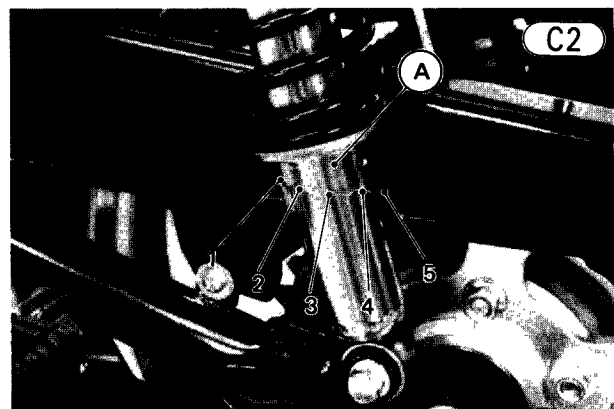

A. Spring Adjusting Sleeve

If the spring action feels too soft or too stiff, adjust it in accordance with the following table:

Table C2 Spring Action

Position	1	2	3	4	5

To adjust the spring force:

- Turn the adjusting sleeve on each shock absorber to the desired position with a hook spanner.
- Check to see that both adjusting sleeves are turned to the same relative position.

WARNING If both spring adjusting sleeves are not adjusted equally, handling may be impaired and a hazardous condition may result.

NOTE: Match the spring adjusting sleeve position with the damper adjuster position referring to the Front and Rear Suspension Setting.

Damper Adjustment

The damper adjuster on each rear shock absorber has 4 positions so that the damping force can be adjusted for different road and loading conditions. The numbers on the adjuster show the setting position of the damper.

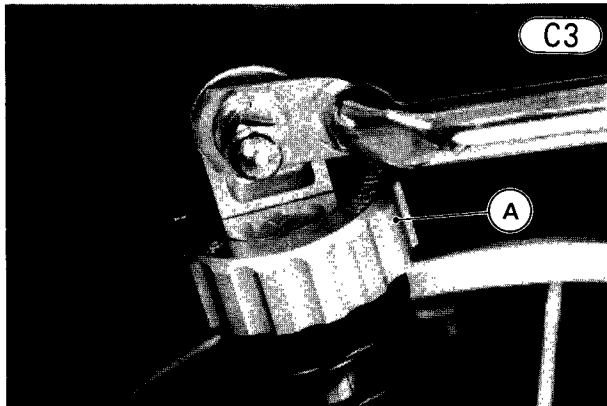

A. Damper Adjuster

If the damper setting feels too soft or too stiff, adjust it in accordance with the following table:

Table C3 Damping Force

Position	1	2	3	4
Damping Force	Larger \longrightarrow			

To adjust the damping force:

- Turn the adjuster to the desired number until you feel a click.

Table C4 Front and Rear Suspension Setting (example)

Suspension Setting	Rear Shock Absorber		Front Fork Air Pressure kg/cm ² (psi, kPa)	
	Spring Force (Sleeve Position)	Damping Force (Adjuster Position)	KZ750-E	KZ750-H
Soft \updownarrow	A	1 or 2	0.6 (8.5, 60)) 0.9 (13, 90)	0.5 (7.1, 50)) 1.0 (14, 100)
	B	2 or 3		
	C	3 or 4		

- Check to see that both adjuster are turned to the same relative position.

WARNING If both damper adjuster are not adjusted equally, handling may be impaired and a hazardous condition may result.

NOTE: Match the damper adjuster position with the spring adjusting sleeve position referring to the Front and Rear Suspension Setting.

FRONT AND REAR SUSPENSION SETTING

The following table shows an example of setting for the front and rear suspension. To obtain the stable handling or suitable riding condition, adjust the air pressure, spring force, or damping force for different road and loading conditions if necessary. For instance, setting A shown in the table is softest and designed for an average-built rider of 68 kg (150 lbs) with no accessories. Ordinarily, the heavier the total load becomes, the harder the suspension should be set.

DRIVE CHAIN

Chain and sprocket wear causes the chain to stretch, which results in power loss, accelerated chain and sprocket wear, and increased noise. A chain that has been adjusted too loose may be thrown off the sprockets. A chain that has been adjusted too tight will wear excessively and possibly break.

To check the drive chain slack:

- Check to see if the drive chain wear is past the service limit (Pg. 198). A chain worn past the service limit must be replaced with a new one.

WARNING A chain worn past the service limit must be replaced. Such wear cannot be adequately compensated for by adjustment.

- Set the motorcycle up on its center stand.
- Rotate the rear wheel to find the position where the chain is tightest, and measure the vertical movement midway between the sprockets. If it is less than 20 mm or more than 35 mm, adjust the chain so that the vertical movement will be about 20~30 mm.

24 ADJUSTMENT—CHASSIS

Drive Chain Slack

C4

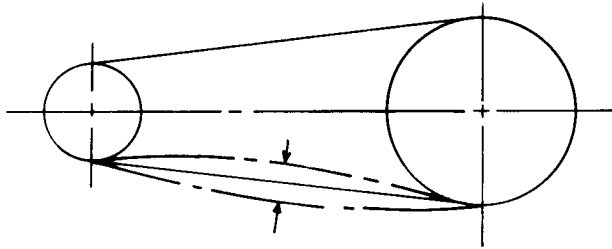

To adjust the drive chain:

- Loosen the nut at the torque link rear end.

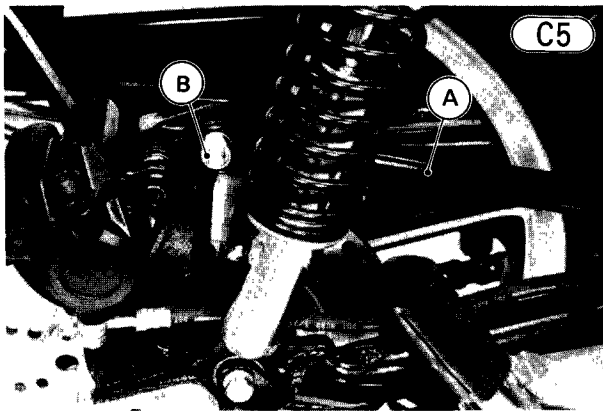

A. Torque Link B. Nut

- Loosen the left and right chain adjuster locknut.

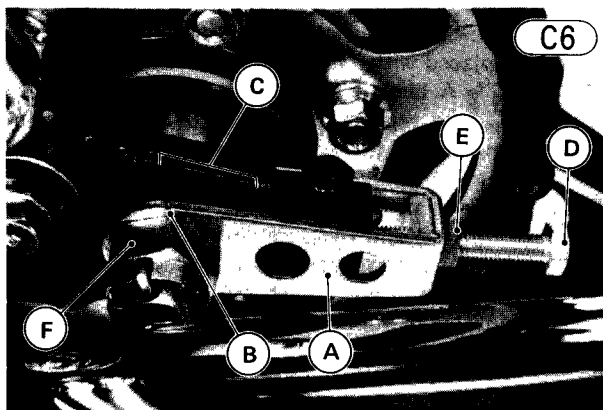

A. Chain Adjuster D. Adjusting Bolt
B. Notch E. Locknut
C. Swing Arm Marks F. Axle Nut

- Remove the cotter pin, and loosen the rear axle nut.
- If the chain is too tight, back out the left and right chain adjusting bolts evenly, and kick the wheel for-

WARNING Take care not to damage the brake hose. Damaging the brake line greatly reduces the brake line strength and causes brake fluid leakage, resulting in the loss of brake control.

- Turn the left and right chain adjusting bolts evenly until the drive chain has the correct amount of slack. To keep the chain and wheel aligned, the notch on the left chain adjuster should align with the same swing arm mark that the right chain adjuster notch aligns with.

NOTE: Wheel alignment can also be checked using the straightedge or string method.

WARNING Misalignment of the wheel will result in abnormal wear, and may result in an unsafe riding condition.

- Tighten both chain adjuster locknuts (Make sure the axle stays aligned).
- Tighten the axle nut to 12.0 kg-m (87 ft-lbs) of torque.
- Rotate the wheel, measure the vertical movement again at the tightest position, and readjust if necessary.
- Tighten the torque link nut to 3.0 kg-m (22 ft-lbs) of torque.
- Insert a new cotter pin through the axle nut and axle, and spread its end.

BRAKES

Front Brake

Disc and disc pad wear is automatically compensated for and has no effect on brake lever action. So there are no parts that require adjustment on the front brake. However if the brake lever has a soft, or "spongy feeling", check the brake fluid level in the master cylinder and bleed the air from the brake line (Pg. 206).

NOTE: Check the brake fluid level in accordance with the Periodic Maintenance Chart (Pg. 10).

Rear Brake

Disc and disc pad wear is automatically compensated for and has no effect on brake pedal action. However, the brake pedal position may occasionally require adjustment due to wear of the brake pedal pivot, or in case of disassembly. If the brake pedal has a soft, or "spongy feeling", check the brake fluid level in the reservoir and bleed the air from the brake line (Pg. 206).

NOTE: Check the brake fluid level in accordance with the Periodic Maintenance Chart (Pg. 10).

To check the brake pedal position:

- When the brake pedal is in its rest position, it should

Table C5 Pedal Position
(lower than the top of the footpeg)

KZ750-E	KZ750-H
8 ~ 12 mm, (E) 13 ~ 17 mm	4 ~ 8 mm

(E): European model, Australian model, and South African model

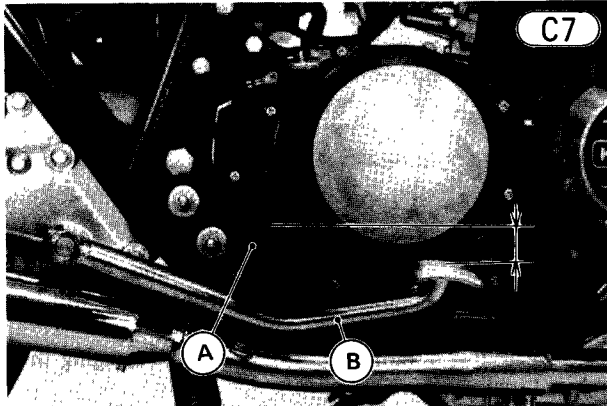

A. Footpeg B. Brake Pedal

●If it is not, adjust the brake pedal position as follows.

To adjust the brake pedal position:

- Remove the brake pedal bolt and brake pedal.
- Use a jack under the right muffler or other suitable means to hold the muffler in place.
- Remove the footpeg mounting bolt, nut, and flat washer.

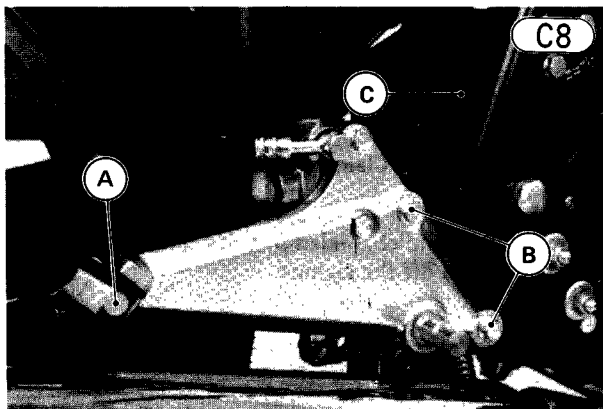

A. Mounting Bolt C. Brake Light Switch Spring
B. Mounting Bracket Bolts

- Remove the muffler mounting bracket bolts (2), and free the rear brake light switch spring from the switch.

CAUTION Take care not to damage the brake hose. Damage the brake line greatly reduces the brake line strength and causes brake fluid leakage, resulting in the loss of brake control.

- Loosen the locknut and turn the push rod to adjust the

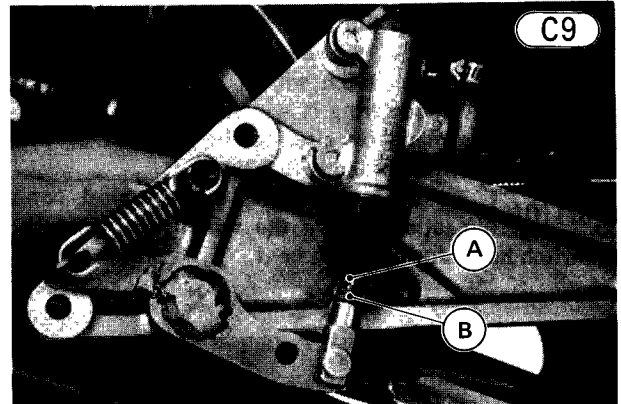

A. Push Rod B. Locknut

- Temporarily install the muffler mounting bracket with its bolts.
 - Install the brake pedal so that the line mark on the pedal is aligned with the punch mark on the shaft, and check the brake pedal position (Fig. C7).
 - If the pedal position is not correct, remove the pedal and bracket, and readjust the position.
- NOTE:** If the pedal position cannot be adjusted by turning the push rod, the brake pedal may be deformed or incorrectly installed.
- Install the rear brake light switch spring between the switch and the tab of the brake pedal shaft arm.
 - Tighten the mounting bracket bolts (2).
 - Install the brake pedal in its correct position, and tighten its bolt.
 - Install the footpeg mounting bolt, and tighten its nut with the flat washer.

BRAKE LIGHT SWITCH

The front brake light switch, mounted on the front brake master cylinder, is operated simple electrical contact and does not need adjustment. However, the rear brake light switch, activated by a spring attached to the brake pedal shaft arm, requires periodic adjustment to compensate for any change in spring shape or tension.

To check and adjust the rear brake light switch:

- Check the operation of the swing by turning on the ignition switch and depressing the brake pedal. The brake light should go on after 15 mm of pedal travel.

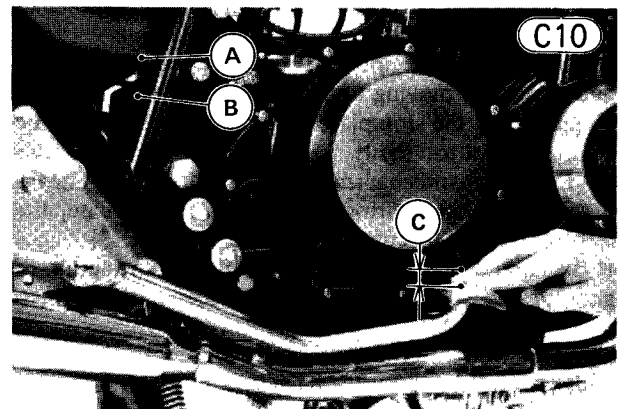

A. Rear Brake Light Switch C. 15 mm

26 ADJUSTMENT—CHASSIS

- If it does not, adjust the switch so that the brake light will go on after the proper amount of brake pedal travel. Raising the switch will make the light go on after less travel; lowering it will require more travel. Adjustment is made by altering the position of the adjusting nut on the brake switch body.

CAUTION To avoid damaging the electrical connections inside the switch, do not turn the switch body during adjustment.

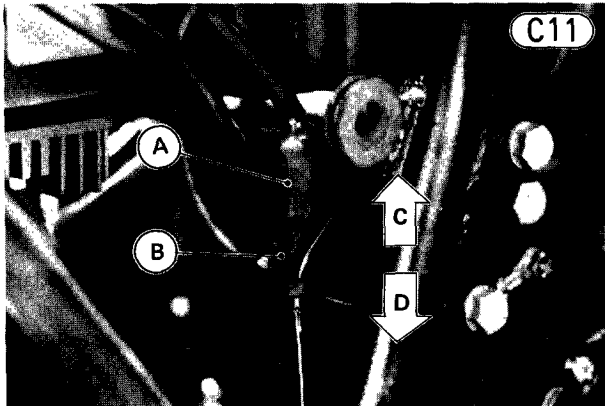

A. Brake Light Switch
B. Adjusting Nut

C. Lights sooner
D. Lights later

STEERING

For safety, the steering should always be kept adjusted so that the handlebar will turn freely but have no play.

If the steering is too tight, it will be difficult to turn the handlebar quickly, the motorcycle may pull to one side, and the steering stem bearings may become damaged. If the steering is too loose, the handlebar will vibrate and the motorcycle will be unstable and difficult to steer in a straight line.

To check the steering adjustment:

- Set the motorcycle on its center stand.
- Using a jack under the engine, lift the front wheel off the ground.
- From the straightforward position of the handlebar, slowly push the handlebar to either side.
- If the handlebar begins to turn by the action of gravity and continues moving until the ridge on the stem base stops against the stop plate on the frame head pipe, the steering is not too tight.

NOTE: The handlebar may catch halfway by means of the cables and wiring harnesses. In this case, the steering couldn't be considered to be too tight.

- If the handlebar does not begin to turn by the action of gravity, the steering is too tight necessitating adjustment.
- Squat in front of the motorcycle and grasp the lower ends of the front fork. Push and pull the fork end back and forth.

If play is felt, the steering is too loose, necessitating

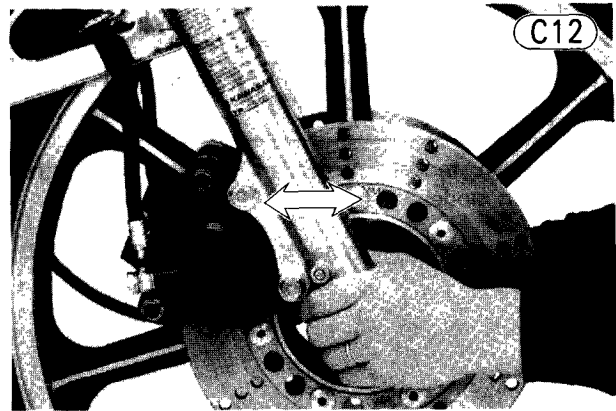

To adjust the steering:

- Put the motorcycle up on its center stand, and jack or prop up the engine so that the front wheel will be off the ground.
- Remove the fuel tank (Pg. 43) to avoid damaging the painted surface.
- Loosen the front fork upper clamp bolts (2) to free the fork tubes from the steering stem during adjustment.

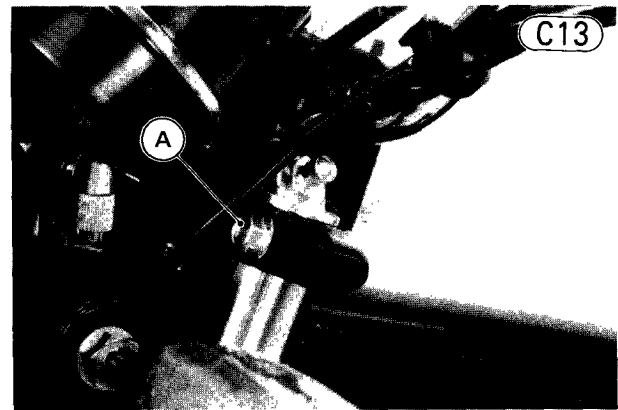

A. Front Fork Upper Clamp Bolt

- Remove the handlebar clamp bolts and lockwashers (4 ea), and take off the clamps.

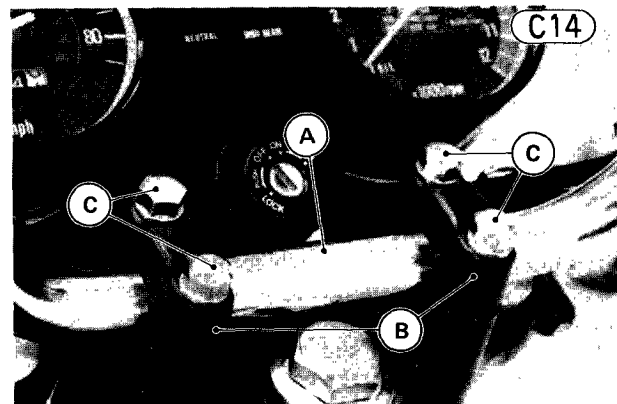

- Loosen the steering stem head bolt and head clamp bolt, and back out the steering stem locknut using the stem nut wrench (special tool) 1 or 2 turns until it turns without drag.

NOTE: Do not back out the steering stem locknut more than a couple of turns. If the locknut is backed off too far, the bearing balls in the steering stem may fall out of place. This will necessitate steering stem removal and installation.

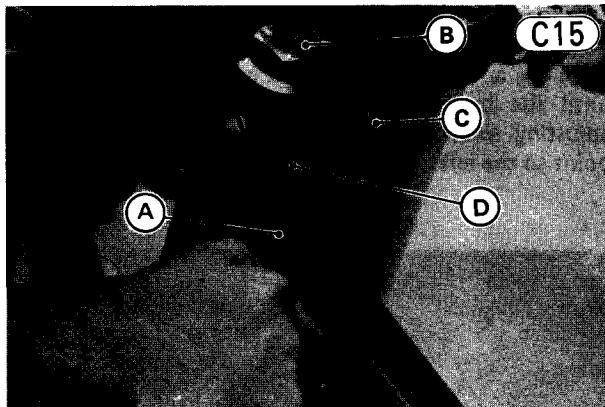

- A. Stem Nut Wrench (57001-1100)
- B. Stem Head Bolt
- C. Head Clamp Bolt
- D. Stem Locknut

- Tighten the stem locknut to 2.0 kg-m (14.5 ft-lbs) of torque.

NOTE: If a suitable torque wrench is not available, tighten the steering stem locknut lightly (until it just becomes hard to turn), and then continue for another 1/16 turn (about 20° travel) from that point.

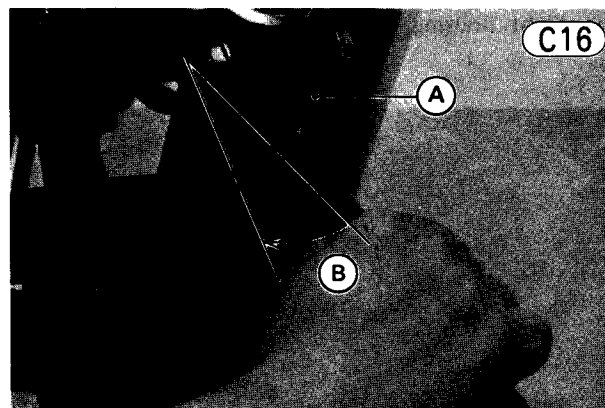

- A. Stem Nut Wrench (57001-1100)
- B. Another 1/16 Turn

- Tighten the steering stem head bolt to 4.0 kg-m (29 ft-lbs) of torque.
- Tighten the steering stem head clamp bolt nut to 1.8 kg-m (13.0 ft-lbs) of torque.
- Tighten the front fork upper clamp bolts (2) to 2.0 kg-m (14.5 ft-lbs) of torque.

- Check the steering again. If the steering is too tight or too loose in spite of correct adjustment, inspect the steering stem parts according to the maintenance section (Pg. 208).
- Install the handlebar referring to the handlebar installation section.
- Remount the fuel tank (Pg. 43).

WHEEL BALANCE

To improve stability and decrease vibration at high speed, the front and rear wheels must be kept balanced. Check and balance the wheels when required, or when a tire is replaced with a new one.

To check the wheel balance:

- Remove the wheel (Pg. 109 or 110).
- Check that the wheel is not damaged.
- Suspend the wheel so that it can be spun freely.
- Spin the wheel lightly, and mark the wheel at the top when the wheel stops.

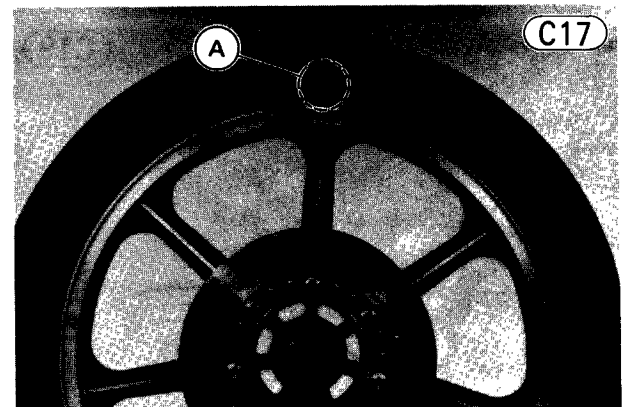

A. Mark

- Repeat this procedure several times. If the wheel stops of its own accord in various positions, it is well balanced.

To adjust the wheel balance:

- If the wheel always stops in one position, provisionally attach a balance weight on the rim at the marking using an adhesive tape.
- Rotate the wheel ¼ turn, and see whether or not the wheel stops in this position. If it does, the correct

28 ADJUSTMENT—CHASSIS

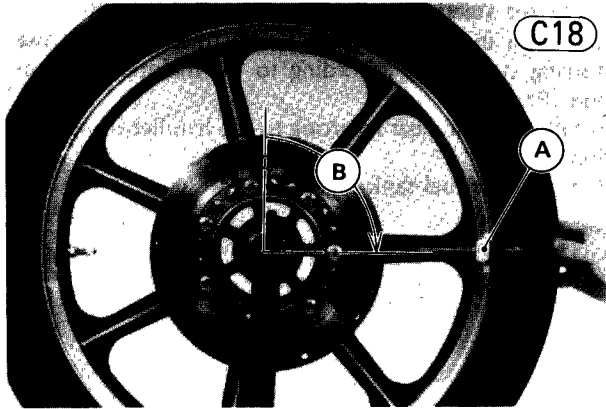

A. Balance Weight B. ¼ Turn

- If the wheel rotates and the weight goes up, replace the weight with the next heavier size. If the wheel rotates and the weight goes down, replace the weight with the next lighter size. Repeat these steps until the wheel remains at rest after being rotated ¼ turn.
- Rotate the wheel another ¼ turn and then another ¼ turn to see if the wheel is correctly balanced.
- Repeat the entire procedure as many times as necessary to achieve correct wheel balance.
- To install the balance weights on the rim, first reduce the tire pressure, pry the tire bead from the rim, and then insert the blade part of the balance weight between the rim and the tire bead until the stepped portion of the weight is hooked over the edge of the rim.

Balance Weight Installation

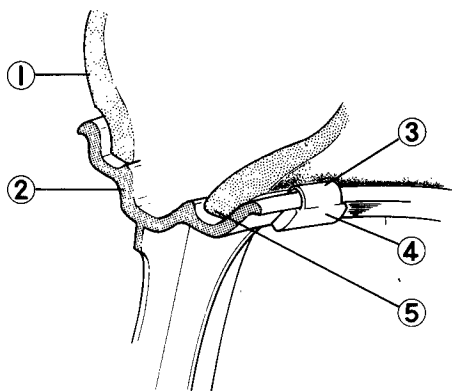

- | | |
|----------|-------------------|
| 1. Tire | 4. Balance Weight |
| 2. Rim | 5. Tire Bead |
| 3. Blade | |

- Inflate the tire to standard pressure (Pg. 193).
- Remount the wheel on the motorcycle (Pg. 109 or 111).

NOTE: Balance weights are available from Kawasaki Dealers in 10, 20, and 30 gram sizes. An imbalance of less than 10 grams will not usually affect running sta-

HEADLIGHT

The headlight beam is adjustable both horizontally and vertically. If not properly adjusted horizontally, the beam will point to one side rather than straight ahead. If adjusted too low vertically, neither low nor high beam will illuminate the road far enough ahead. If adjusted too high vertically, high beam will fail to illuminate the road close ahead, and low beam will blind oncoming drivers.

Horizontal Adjustment

- Turn the adjusting screw on the headlight rim in or out until the beam points straight ahead. Turning the adjusting screw clockwise makes the headlight beam point to the left.

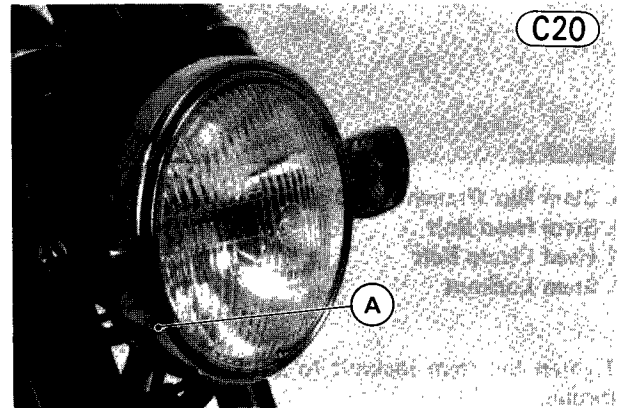

A. Adjusting Screw

Vertical Adjustment

- Remove the two screws from the lower side of the headlight housing, and drop out the headlight unit.

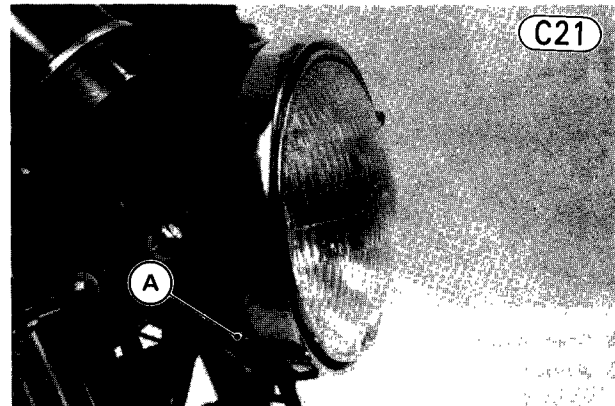

A. Screw

- Loosen the headlight housing mounting nuts, and loosen the housing mounting bolt underneath the head-

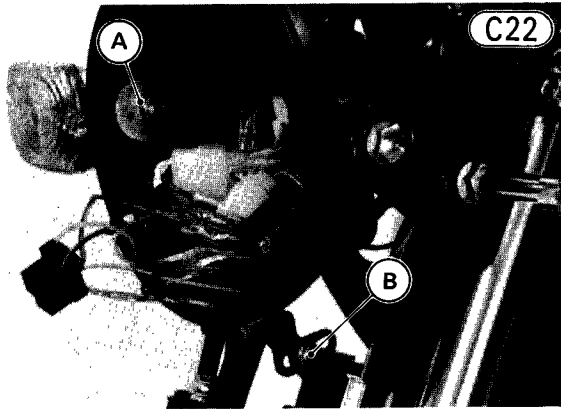

A. Mounting Nut

B. Mounting Bolt

● Move the headlight housing up or down so that the vertical aim is correct, and then tighten the mounting nuts to hold it there.

NOTE: On high beam, the brightest point should be slightly below horizontal. Adjust the headlight to the proper angle according to local regulation that applies to its operation. Adjust with normal operational weight loaded on the motorcycle.

Vertical Adjustment

C23

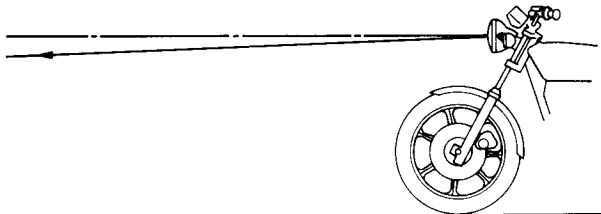

● Remount the headlight unit.

GENERAL LUBRICATION

Lubrication of exposed parts subject to rust with either motor oil or regular grease should be carried out periodically and whenever the vehicle has been operated

Avoid spraying water with any great force near the meter assembly, and under the fuel tank and the seat to prevent damage to electrical components. Exposed parts that are subject to rust can be treated with a protective polish or a water-displacing oil (brand-name examples: WD-40, LPS).

WARNING Never wax or lubricate brake discs. Loss of braking and an accident could result. Clean discs with an oilless solvent such as trichloroethylene or acetone. Observe solvent manufacturer's warnings.

Brake Lever

C24

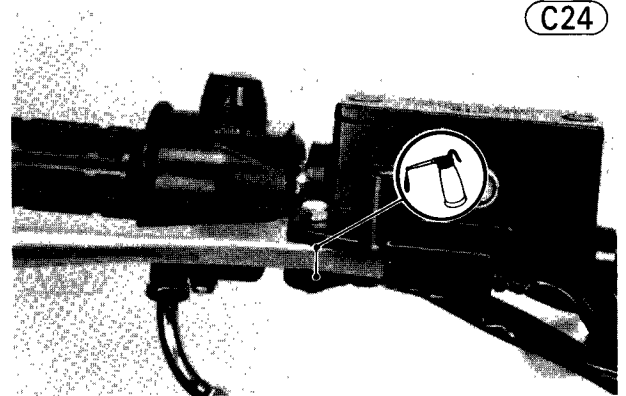

Clutch Lever

C25

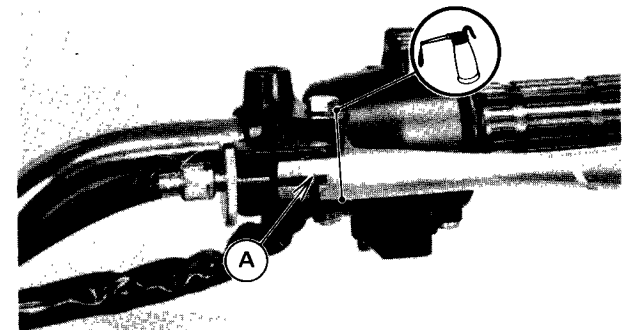

A. Grease.

Throttle Grip

Apply grease to the handlebar where the throttle grip turns.

Apply a light coat of grease to the exposed portion of the throttle grip inner cable and its catch in the throttle grip.

Fit the throttle cable into the throttle grip. Refer to

30 ADJUSTMENT—CHASSIS

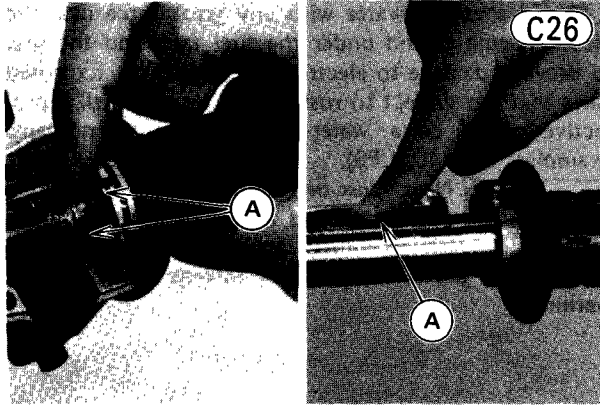

A. Grease.

Right Footpeg, Brake Push Rod Joint

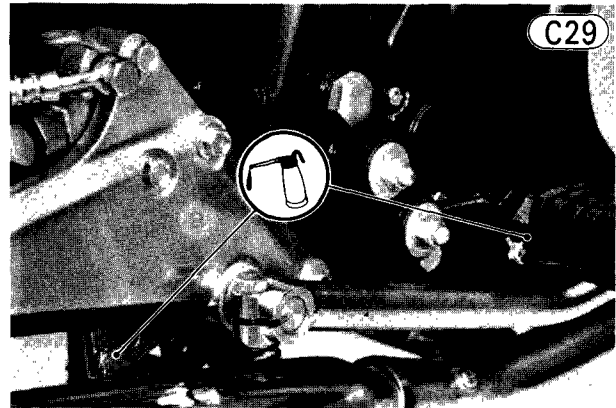

Clutch and Throttle Cables

Lubricate the clutch cable and throttle cable, as shown in the figure. Use a lubricant designed for cable lubrication. Refer to Pgs. 127 and 128.

Cable Lubrication

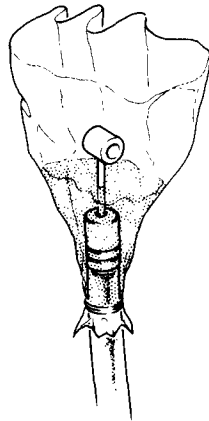

Center Stand

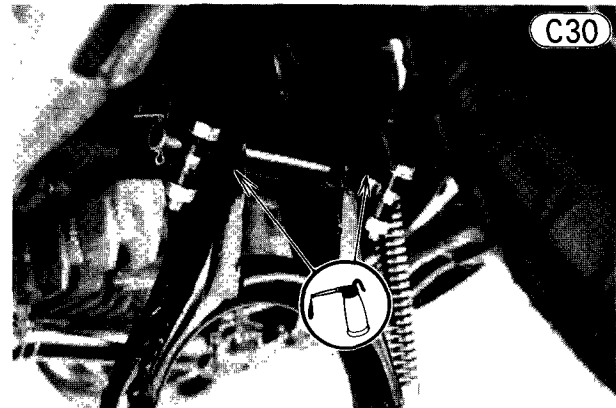

Left Footpeg, Side Stand

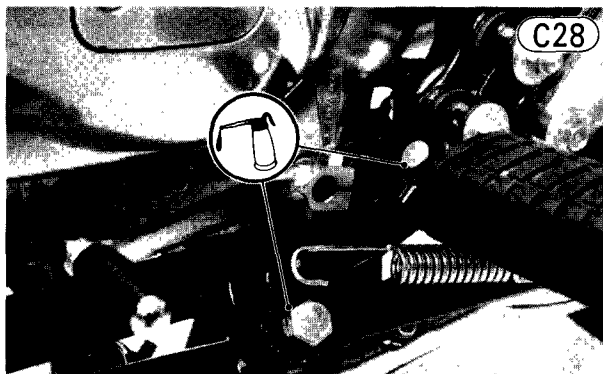

Speedometer and Tachometer Cables

Apply grease sparingly to these inner cables.

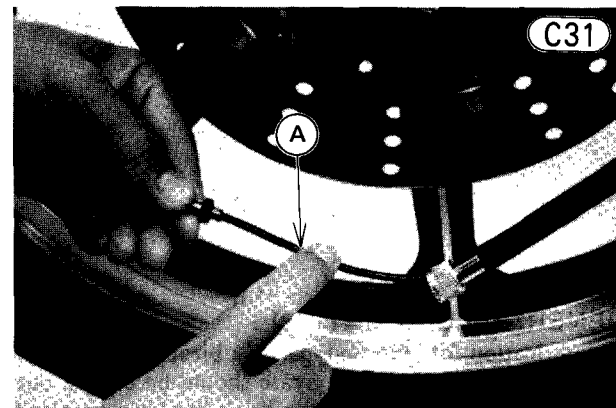

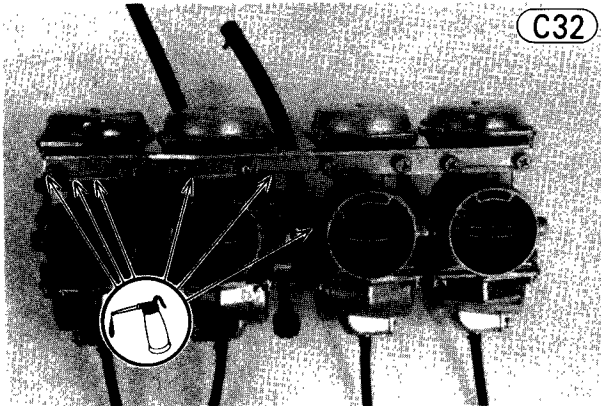
Carburetor Choke Link Mechanism

NOTE: A few drops of oil are effective to keep bolts and nuts from rusting and sticking. This makes easy removal at your next work. Badly rusted nuts, bolts, etc. should be replaced with new ones.

Disassembly—Introduction

Table of Contents

INTRODUCTION TO DISASSEMBLY	34
TORQUE AND LOCKING AGENT	35



34 DISASSEMBLY—INTRODUCTION

INTRODUCTION TO DISASSEMBLY

Detail has not been spared in this section in order that the motorcycle can not only be taken apart but also put back together properly as well. Photographs, diagrams, notes, cautions, warnings, and detailed descriptions have been included wherever necessary. Nevertheless, even a detail account has limitations; a certain amount of basic knowledge is also required for successful work.

Especially note the following:

(1) Edges

Watch for sharp edges, especially during major engine disassembly and assembly. Protect your hands with gloves or a piece of thick cloth when lifting the engine or turning it over.

(2) Dirt

Before removal and disassembly, clean the motorcycle. Any dirt entering the engine, carburetor or other parts will work as an abrasive and shorten the life of the motorcycle. For the same reason, before installing a new part, clean off any dust or metal fillings.

(3) Tightening Sequence

Where there is a tightening sequence indication in this Service Manual; the bolts, nuts, or screws must be tightened in the order and method indicated. When installing a part with several bolts, nuts, or screws; they should all be started in their holes and tightened to a snug fit. Then tighten them evenly, according to the tightening sequence, to the specified torque. This is to avoid distortion of the part and/or causing gas or oil leakage. Conversely when loosening the bolts, nuts, or screws; loosen all of them about a quarter of turn and then remove them.

(4) Torque

The torque values given in this Service Manual should always be adhered to. Either too little or too much torque may lead to serious damage. Use a good quality, reliable torque wrench.

(5) Force

Common sense should dictate how much force is necessary in assembly and disassembly. If a part seems especially difficult to remove or install, stop and examine what may be causing the problem. Whenever tapping is necessary, tap lightly using a wooden or plastic-faced mallet. Use an impact driver for screws (particularly for the removal of screws held by a locking agent) in order to avoid damaging the screw heads.

(6) Lubricant

Don't use just any oil or grease. Some oils and greases in particular should be used only in certain applications and may be harmful if used in an application for which they are not intended.

(7) Battery Ground

Before performing any disassembly operations on the motorcycle, remove the ground (—) lead from the battery to prevent the possibility of accidentally turning the engine over while partially disassembled.

(8) Engine Rotation

When turning the crankshaft by hand, always turn it in the direction of normal rotation; which is clockwise, viewed from the right side of the engine. This will ensure proper adjustments.

(9) Lubrication

Engine wear is generally at its maximum while the engine is warming up and before all the rubbing surfaces have an adequate lubricative film. During assembly, oil or grease (whichever is more suitable) should be applied to any rubbing surface which has lost its lubricative film. Old grease and dirty oil should be cleaned off. Deteriorated grease has lost its lubricative quality and may contain abrasive foreign particles.

(10) Press

A part installed using a press or driver, such as a wheel bearing, should first be coated with oil on its outer or inner circumference so that it will go into place smoothly.

(11) Oil Seal, Grease Seal

Replace any oil or grease seals that were removed with new ones, as removal generally damages seals. A seal guide is required for certain oil or grease seals during installation to avoid damage to the seal lips. Before a shaft passes through a seal, apply a little oil, preferably high temperature grease on the lips to reduce rubber to metal friction.

(12) Gasket, O Ring

When in doubt as to the condition of a gasket or O ring, replace it with a new one. The mating surfaces around the gasket should be free of foreign matter and perfectly smooth to avoid oil

(13) Liquid Gasket, Non-permanent Locking Agent

Follow manufacturer's directions for cleaning and preparing surfaces where these compounds will be used. Apply sparingly. Excessive amounts may block engine oil passages and cause serious damage. An example of a non-permanent locking agent commonly available in North America is Loctite Lock'n Seal (Blue).

(14) Ball Bearing, Oil Seal, Grease Seal Installation

When installing a ball bearing, the bearing race which is affected by friction should be pushed by a suitable driver. This prevents severe stress on the balls and races, and prevents races and balls from being dented. Press a ball bearing until it stops at the stop in the hole or on the shaft. Seals should be pressed into place using a suitable driver, which contacts evenly with the side of the seal until the face of the seal is even with the end of the hole.

(15) Circlip, Retaining Ring

Replace any circlips and retaining rings that were removed with new ones, as removal weakens and deforms them. When installing circlips and retaining rings, take care to compress or expand them only enough to install them and no more.

(16) High Flash-point Solvent

A high flash-point solvent is recommended to reduce fire danger. A commercial solvent commonly available in North America is Stoddard solvent (generic name). Always follow manufacturer and container directions regarding the use of any solvent.

(17) Molybdenum Disulfide (MoS₂) Grease

This manual makes reference to molybdenum disulfide grease in the assembly of certain engine and chassis parts. Always check manufacturer recommendations before using such special lubricants.

(18) Electrical Leads

All the electrical leads are either single-color or two-color and, with only a few exceptions, must be connected to leads of the same color. On any of the two-color leads there is a greater amount of one color and a lesser amount of a second color, so a two-color lead is identified by first the primary color and then the secondary color. For example, a yellow wire with thin red stripes is referred to as a "yellow/red" wire; it would be a "red/yellow" wire if the colors were reversed to make red the main color.

TORQUE AND LOCKING AGENT

Tighten all bolts and nuts to the proper torque using an accurate torque wrench. If insufficiently tightened, a bolt or nut may become damaged or fall off, possibly resulting in damage to the motorcycle and injury to the rider. A bolt or nut which is overtightened may become damaged, strip an internal thread, or break and then fall out. The following table lists the tightening torque for the major bolts and nuts, and the parts requiring use of a non-permanent locking agent or liquid gasket.

Parts marked with a cross (†) must be retorqued according to the Periodic Maintenance Chart (Pg. 10). One at a time, loosen each bolt or nut ½ turn, then tighten it to the specified torque. Follow the sequence if specified. For engine fasteners, retorque them when the engine is cold (at room temperature).

NOTE: Marks used in "Remark"

- : Apply a non-permanent locking agent to the threads.
- ★ : Apply a liquid gasket to the threads or washer.

ENGINE

Part	Quantity	Torque		Remark	See Pg.
		Metric (kg-m)	English (ft-lbs)		
Air suction valve cover bolts ϕ 6 P1.0	(8)	0.80	69 in-lbs	—	52
Alternator rotor bolt ϕ 10 P1.25	1	7.0	51	—	72
Alternator stator Allen bolts ϕ 5 P0.8	3	0.80	69 in-lbs	•	71
...

36 DISASSEMBLY—INTRODUCTION

Part	Quantity	Torque		Remark	See Pg.
		Metric (kg-m)	English (ft-lbs)		
Camshaft cap bolts $\phi 6$ P1.0	16	1.2	104 in-lbs	—	55
Camshaft sprocket bolts $\phi 6$ P1.0	4	1.5	11.0	•	57
Carburetor holder screws $\phi 6$ P1.0	8	—	—	•	—
Clutch hub locknut $\phi 20$ P1.5	1	13.5	98	—	75
Clutch release mounting screws $\phi 6$ P1.0	2	—	—	•	66
Clutch spring bolts $\phi 6$ P1.0	5	0.90	78 in-lbs	—	76
Connecting rod big end cap nuts $\phi 8$ P0.75	8	3.7	27	—	105
Crankcase bolts					
(upper) $\phi 6$ P1.0	13	1.0	87 in-lbs	—	96
(lower) $\phi 6$ P1.0	7	1.0	87 in-lbs	—	94
(lower) $\phi 8$ P1.25	10	2.5	18.0	—	93
†Cylinder head					
bolts $\phi 8$ P1.25	2	3.0	22	—	58
nuts $\phi 10$ P1.25	12	4.0	29	—	57
Cylinder head cover bolts $\phi 6$ P1.0	(24)	0.80	69 in-lbs	—	56
Drive chain guard bolts $\phi 6$ P1.0	3	—	—	•	68
Engine drain plug $\phi 12$ P1.5	1	3.8	27	—	19
†Engine mounting bolts $\phi 10$ P1.25	6	4.0	29	—	88
†Engine mounting bracket bolts $\phi 8$ P1.25	6	2.4	17.5	—	88
Engine sprocket nut $\phi 20$ P1.5	1	8.0	58	—	67
†Muffler					
exhaust pipe holder nuts $\phi 6$ P1.0	8	—	—	—	50
exhaust pipe clamp bolts $\phi 8$ P1.25	2	—	—	—	50
connecting pipe clamp bolts $\phi 8$ P1.25	2	—	—	—	50
rear mounting nuts (bracket) $\phi 8$ P1.25	4	—	—	—	25
rear mounting bolts (footpeg) $\phi 10$ P1.25	2	—	—	—	50
Neutral switch $\phi 12$ P1.5	1	1.5	11.0	—	69
Oil filter mounting bolt $\phi 20$ P1.5	1	2.0	14.5	—	77
Oil pan bolts $\phi 6$ P1.0	15	1.0	87 in-lbs	—	77
Oil pressure switch PT1/8	1	1.5	11.0	—	74
Oil pressure relief valve $\phi 12$ P1.25	1	1.5	11.0	•	77
Return spring pin (bolt) $\phi 8$ P1.5	1	2.5	18.0	•	67
Secondary shaft nut $\phi 18$ P1.5	1	6.0	43	—	81

Part	Quantity	Torque		Remark	See Pg.
		Metric (kg-m)	English (ft-lbs)		
Shift drum pin plate screw $\phi 6$ P1.0	1	—	—	•	101
†Shift pedal bolt $\phi 6$ P1.0	1	—	—	—	65
Spark plugs $\phi 14$ P1.25	4	2.8	20	—	12
Starter motor clutch Allen bolts $\phi 8$ P1.25	3	3.5	25	•	82
Studs					
(cylinder head) $\phi 6$ P1.0	8	—	—	•	—
(crankcase) $\phi 10$ P1.25	12	—	—	•	—
Timing advancer mounting bolt $\phi 8$ P1.25	1	2.5	18.0	—	73

CHASSIS

Part	Quantity	Torque		Remark	See Pg.
		Metric (kg-m)	English (ft-lbs)		
†Clutch lever holder bolt $\phi 6$ P1.0	1	—	—	—	136
Disc brake parts	See Table for Brake Parts.				38
†Footpeg mounting					
nuts (front) $\phi 10$ P1.25	4	—	—	—	65
bolts (rear) $\phi 10$ P1.25	2	—	—	—	50
†Front axle					
nuts (KZ750-E) $\phi 16$ P1.5	2	8.0	58	—	110
nut (KZ750-H) $\phi 14$ P1.5	1	8.0	58	—	109
†Front axle clamp					
nuts (KZ750-E) $\phi 8$ P1.25	4	1.8	13.0	—	110
bolt (KZ750-H) $\phi 8$ P1.25	1	2.0	14.5	—	109
†Front fender mounting bolts $\phi 8$ P1.25	4	—	—	—	—
Front fork air valves $\phi 10$ P1.25	2	1.2	104 in-lbs	•	140
Front fork bottom Allen bolts $\phi 8$ P1.25	2	2.3	16.5	•, ★	141
†Front fork clamp bolts					
(upper) $\phi 8$ P1.25	2	2.0	14.5	—	139
(lower) $\phi 10$ P1.25	2	3.8	27	—	139
Front fork drain screws $\phi 4$ P0.7	2	—	—	★	141
Front fork top plugs $\phi 28$ P1.0	2	2.3	16.5	—	141
†Handlebar clamp bolts $\phi 8$ P1.25	4	1.8	13.0	—	137

38 DISASSEMBLY—INTRODUCTION

Part	Quantity	Torque		Remark	See Pg.
		Metric (kg-m)	English (ft-lbs)		
† Rear shock absorber mounting nuts $\phi 10$ P1.25	2	3.0	22	—	143
bolts $\phi 10$ P1.25	2	3.0	22	—	143
Rear sprocket nuts $\phi 10$ P1.25	6	4.0	29	—	115
† Side stand pivot bolt nut $\phi 10$ P1.25	1	—	—	—	—
† Steering stem head bolt $\phi 16$ P1.5	1	4.0	29	—	27,139
† Steering stem head clamp bolt nut $\phi 8$ P1.25	1	1.8	13.0	—	27,139
Steering stem locknut $\phi 30$ P1.0	1	2.0	14.5	—	27,139
† Swing arm pivot shaft nut $\phi 16$ P1.5	1	10.0	72	—	144
Tire air valve nuts $\phi 8$ P0.8	2	0.15	13 in-lbs	—	117
† Torque link bolt nuts $\phi 10$ P1.25	2	3.0	22	—	24,145

BRAKE

Part	Quantity	Torque		Remark	See Pg.
		Metric (kg-m)	English (ft-lbs)		
Bleed valves $\phi 7$ P1.0	3	0.80	69 in-lbs	—	119
Brake hose					120,122,
banjo bolts $\phi 10$ P1.25	7	2.5	18.0	—	125,126
clamp screws (built in the clamp)	2	0.10	9 in-lbs	—	125
Brake lever pivot					
bolt $\phi 6$ P1.0	1	0.30	26 in-lbs	—	124
locknut $\phi 6$ P1.0	1	0.60	52 in-lbs	—	124
† Brake pedal bolt $\phi 8$ P1.25	1	—	—	—	—
Caliper holder shaft bolts $\phi 8$ P1.25	6	1.8	13.0	—	119
Disc mounting Allen bolts $\phi 8$ P1.25	21	2.3	16.5	—	116
† Front caliper mounting bolts $\phi 10$ P1.25	4	4.0	29	—	120
† Front master cylinder clamp bolts $\phi 6$ P1.0	2	0.90	78 in-lbs	—	122
† Rear caliper mounting bolt nut (torque link) $\phi 10$ P1.25	1	3.0	22	—	24
† Rear master cylinder mounting bolts	2	—	—	—	125

The table below, relating tightening torque to thread diameter and pitch, lists the basic torque for the bolts and nuts used on Kawasaki Motorcycles. However, the actual torque that is necessary may vary amount bolts and nuts with the same thread diameter and pitch. The bolts and nuts listed on Pg. 35 ~ 38 vary to a greater or lesser extent from what is given in this table. Refer to this table for only the bolts and nuts not included in the table on Pg. 35 ~ 38. All of the values are for use with dry solvent-cleaned threads.

Coarse threads

dia (mm)	pitch (mm)	kg-m	ft-lbs
5	0.80	0.35 ~ 0.50	30 ~ 43 in-lbs
6	1.00	0.60 ~ 0.90	52 ~ 78 in-lbs
8	1.25	1.6 ~ 2.2	11.5 ~ 16.0
10	1.50	3.1 ~ 4.2	22 ~ 30
12	1.75	5.4 ~ 7.5	39 ~ 54
14	2.00	8.3 ~ 11.5	60 ~ 83
16	2.00	13.0 ~ 18.0	94 ~ 130
18	2.50	18.0 ~ 25	130 ~ 181
20	2.50	26 ~ 35	188 ~ 253

Fine threads

dia (mm)	pitch (mm)	kg-m	ft-lbs
5	0.50	0.35 ~ 0.50	30 ~ 43 in-lbs
6	0.75	0.60 ~ 0.80	52 ~ 69 in-lbs
8	1.00	1.4 ~ 1.9	10.0 ~ 13.5
10	1.25	2.6 ~ 3.5	19.0 ~ 25
12	1.50	4.5 ~ 6.2	33 ~ 45
14	1.50	7.4 ~ 10.2	54 ~ 74
16	1.50	11.5 ~ 16.0	83 ~ 116
18	1.50	17.0 ~ 23	123 ~ 166
20	1.50	23 ~ 33	166 ~ 239

Disassembly—Engine Installed

Table of Contents

FLOW CHART	42
FUEL TANK	43
FUEL TAP, FUEL LEVEL SENSOR	43
AIR CLEANER ELEMENT	45
CARBURETORS	45
MUFFLERS	50
IGNITION COILS	51
VACUUM SWITCH VALVE, SILENCER	51
AIR SUCTION VALVES	52
TOP END	
CAMSHAFT CHAIN TENSIONER	52
CAMSHAFTS	53
CAMSHAFT SPROCKETS	56
CYLINDER HEAD	57
VALVES, VALVE GUIDES	58
CYLINDER BLOCK	60
CAMSHAFT CHAIN GUIDES (Upper, Front, Rear)	62
PISTONS, PISTON RINGS	62
BREATHER COVER	64
LEFT SIDE	
ENGINE SPROCKET COVER	65
CLUTCH RELEASE	65
ENGINE SPROCKET	66
EXTERNAL SHIFT MECHANISM	67
NEUTRAL SWITCH	68
STARTER MOTOR	69
ALTERNATOR STATOR	70
ALTERNATOR ROTOR	71
RIGHT SIDE	
PICK-UP COIL ASSEMBLY	72
TIMING ADVANCER	73
OIL PRESSURE SWITCH	74
CLUTCH	74
BOTTOM END	
OIL FILTER, BYPASS VALVE	76
OIL PAN, OIL PRESSURE RELIEF VALVE	77
ENGINE OIL PUMP	77
SECONDARY SHAFT, STARTER MOTOR CLUTCH	78

42 DISASSEMBLY-ENGINE INSTALLED

DISASSEMBLY CHART Engine Installed

The following chart is intended to be aids to proper removal. Select the component you wish to remove and follow the arrows to that point on the chart.

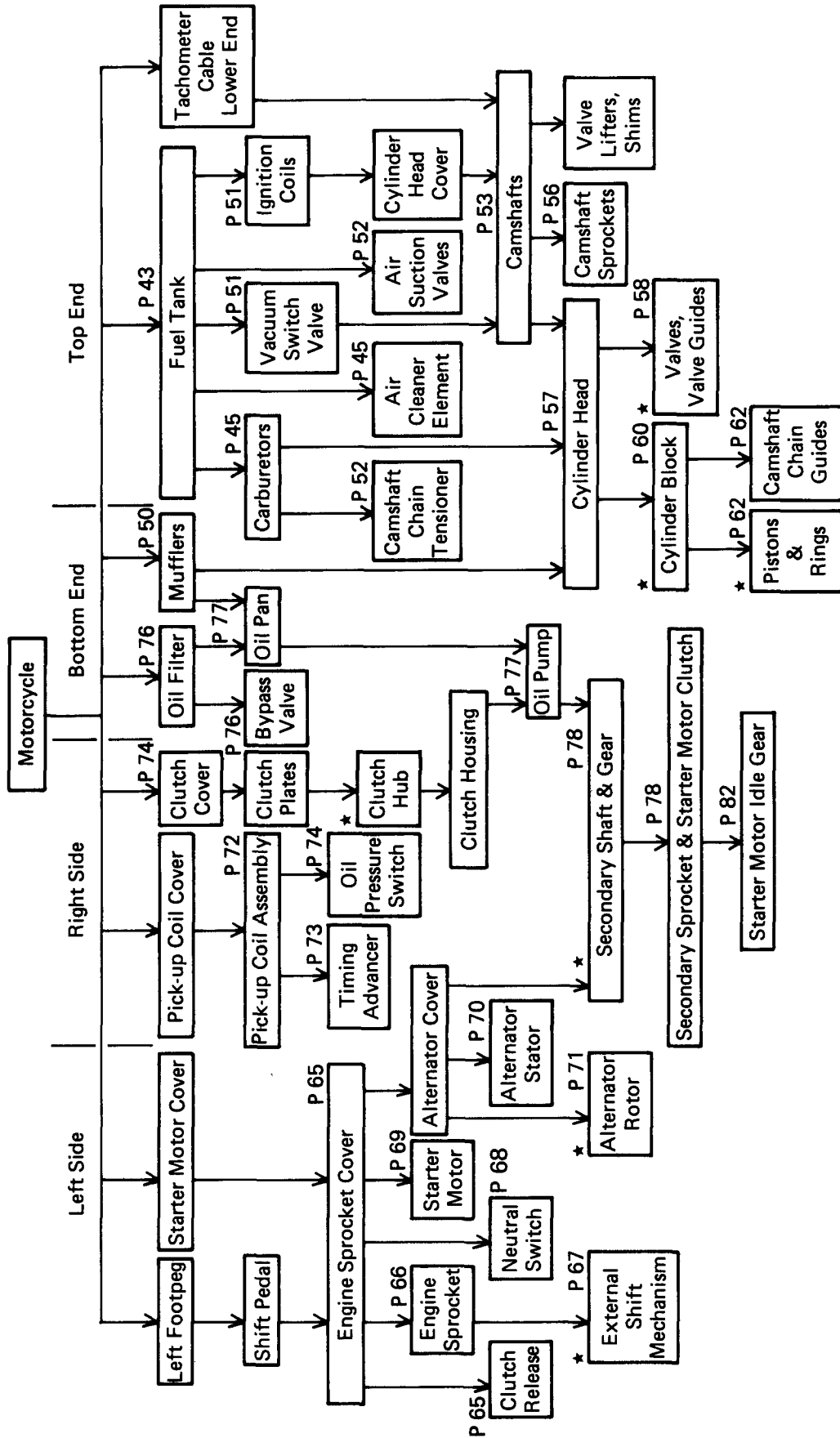

- NOTES:**
1. Before performing any disassembly operations, remove the ground (—) lead from the battery to prevent the possibility of accidentally turning the engine over.
 2. Action with a mark (*) requires special tool(s) for removal, installation, disassembly, or assembly.

FUEL TANK

Removal:

- Unlock the seat and swing it open.
- Turn the fuel tap to the "ON" or "RES" position, slide the hose clamps down, and pull the fuel hose and vacuum hose off the tap.
- For KZ750-H, disconnect the 2-pin connector from the low fuel warning sensor under the fuel tank.
- Remove the fuel tank retaining bolt. The bolt has a flat washer and collar.
- Lift the rear end of the fuel tank up about 30 mm and then pull the fuel tank off toward the rear.

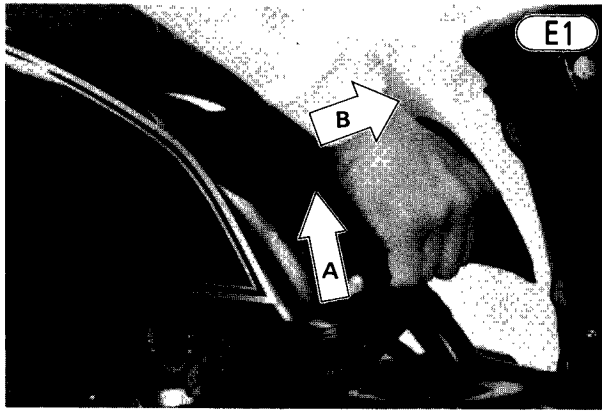

- A. Lift up about 30 mm.
- B. Pull off toward the rear.

Installation:

- Install the retaining rubber on the frame top tube.
- Mount the fuel tank. Fit the fuel hose and vacuum hose back onto the fuel tap, and slide the hose clamps back into place. The vacuum hose has a small diameter than the fuel hose.

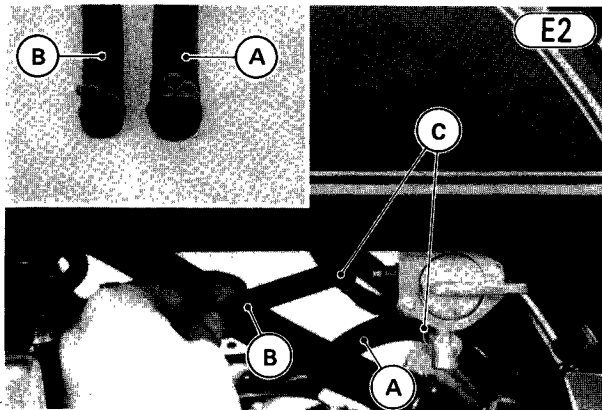

- A. Fuel Hose
- B. Vacuum Hose
- C. Clamps

- Install the fuel tank completely. Tighten the retaining

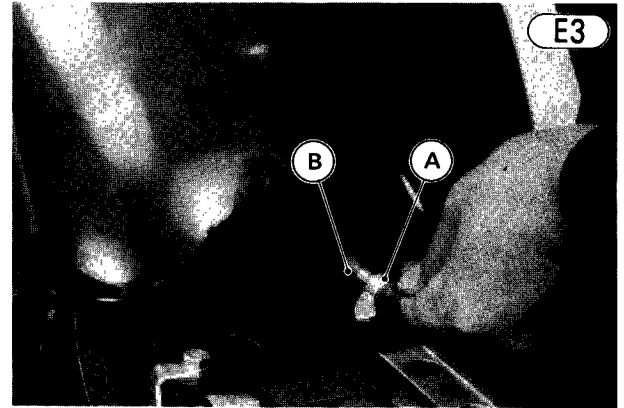

- A. Retaining Bolt
- B. Collar

- Push the seat back down.
- For KZ750-H, connect the 2-pin connector of the low full warning sensor.

FUEL TAP, FUEL LEVEL SENSOR

Removal:

- Remove the fuel tank.
- Holding a container under the fuel tap, turn the tap to the "PRI" position to drain the tank.
- Remove the bolts and gaskets, and pull the fuel tap off the fuel tank. Be careful not to damage the filter.

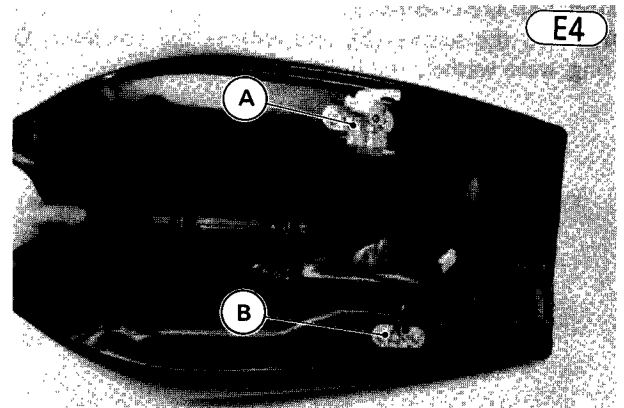

- A. Fuel Tap
- B. Fuel Level Sensor

- For KZ750-H, remove the screws and gaskets, and pull the fuel level sensor off the fuel tank. Be careful not

44 DISASSEMBLY—ENGINE INSTALLED

Fuel Tap

E5

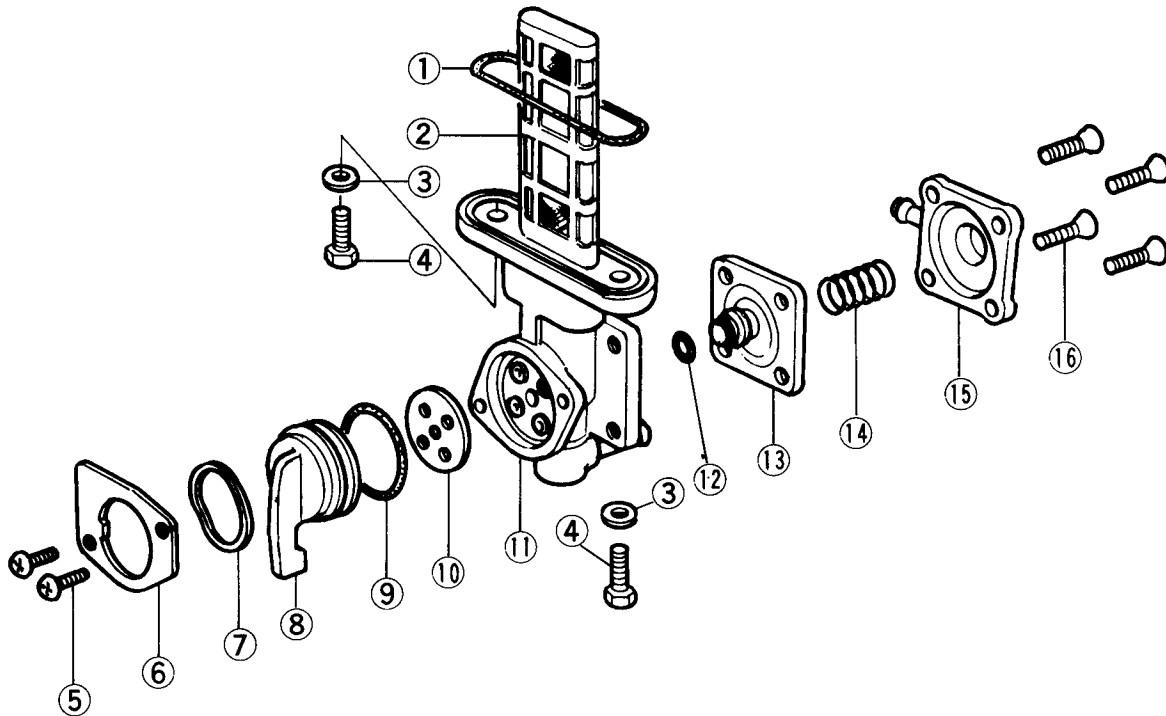

- 1. O Ring
- 2. Filter
- 3. Gasket
- 4. Mounting Bolt

- 5. Screw
- 6. Holding Plate
- 7. Wave Washer
- 8. Tap Lever

- 9. O Ring
- 10. Valve Gasket
- 11. Fuel Tap Body
- 12. O Ring

- 13. Diaphragm Assembly
- 14. Spring
- 15. Diaphragm Cover
- 16. Screw

Installation Notes:

1. Check the O ring, and replace it with a new one if it is damaged or deteriorated.
2. After installing the fuel tap on the tank, make sure that the fuel stops when the engine stops.
3. The vacuum hose is the small diameter hose; the fuel hose is larger (Fig. E2).

Fuel Tap Disassembly:

- Remove the screws (2), and remove the tap lever, O ring, wave washer, and holding plate.

- Take out the valve gasket.
- Remove the screws, diaphragm cover, and spring.

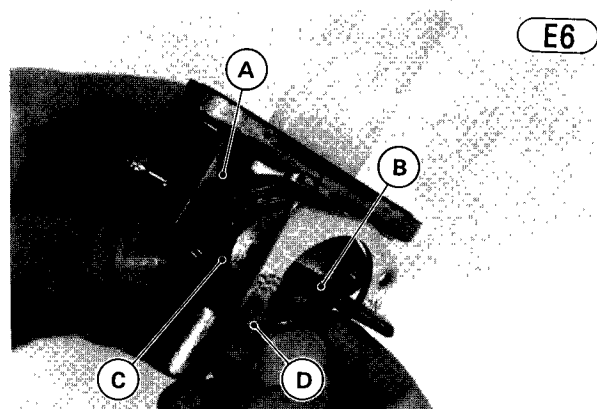

E6

A. Fuel Tap Body

C. Wave Washer

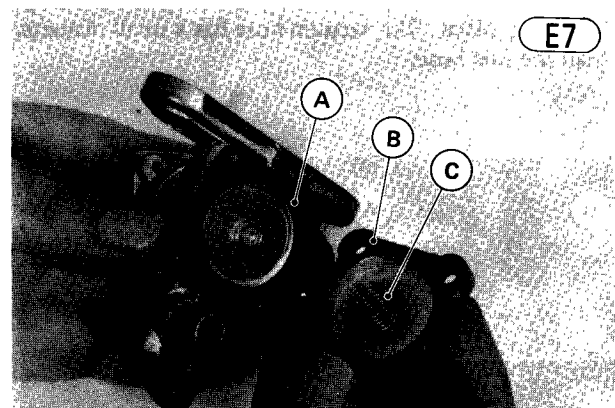

E7

A. Diaphragm Assembly
B. Diaphragm Cover

C. Spring

- Remove the diaphragm assembly from the fuel tap.

Fuel Tap Assembly Notes:

1. Check and clean all the parts (Pg. 149). Replace damaged parts with new ones.
2. Install the diaphragm plate so that the groove in the

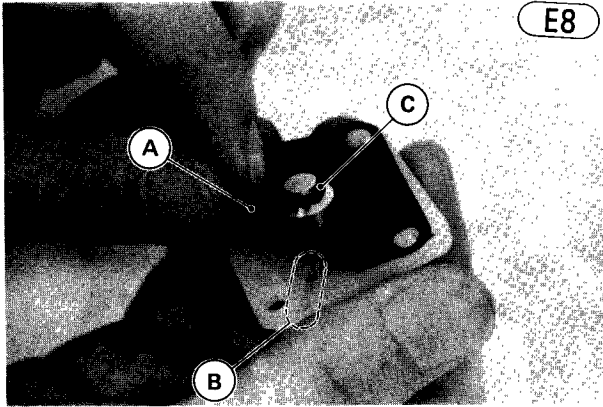

E8

A. Diaphragm Plate B. Groove C. O Ring

3. Install the diaphragm cover in the direction shown in Fig. E9, making sure that the spring is compressed at the center of the diaphragm between the diaphragm and the cover.

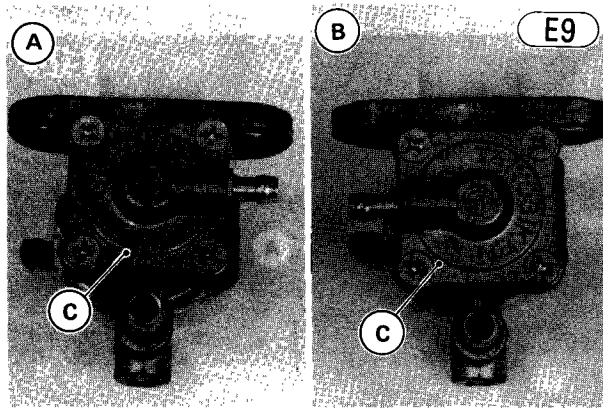

E9

A. KZ750-E B. KZ750-H C. Diaphragm Cover

AIR CLEANER ELEMENT

Removal:

- Unlock the seat, and swing it open.
- Remove the fuel tank (Pg. 43).
- Unscrew the air cleaner cap, and remove the cap and air cleaner element.

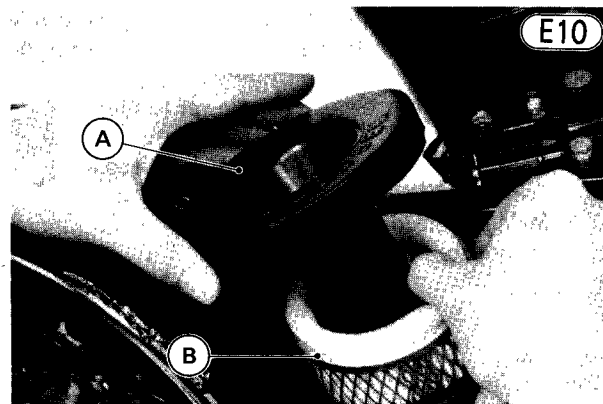

E10

Installation Note:

- When installing the air cleaner cap, screw the cap on until you feel a click.

CARBURETORS

This section is divided as follows:

- Carburetor Removal and Installation
- Carburetor Body Disassembly and Assembly
- Separation of Carburetors and Assembly
- Fast Idle Mechanism Adjustment

Removal:

- Remove the fuel tank (Pg. 43).
- Take off the right and left side covers.
- Loosen the carburetor holder clamps (4).
- Slide the spring bands (4) of the air cleaner ducts out of place.

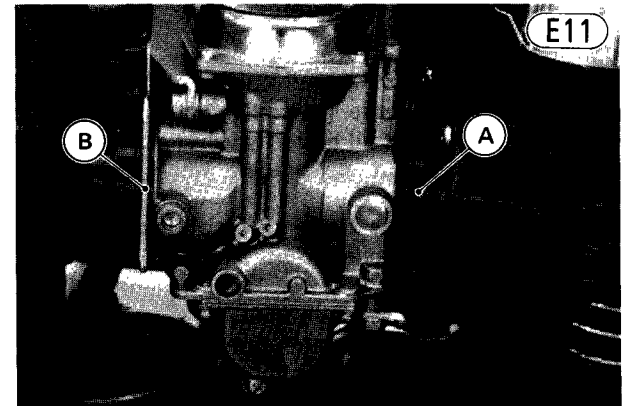

E11

A. Carburetor Holder Clamp B. Spring Band

- Slide the hose clamps up, and pull the vacuum hoses off the carburetors.
- Loosen the locknuts of the throttle cable adjuster, and free the adjuster from its bracket.

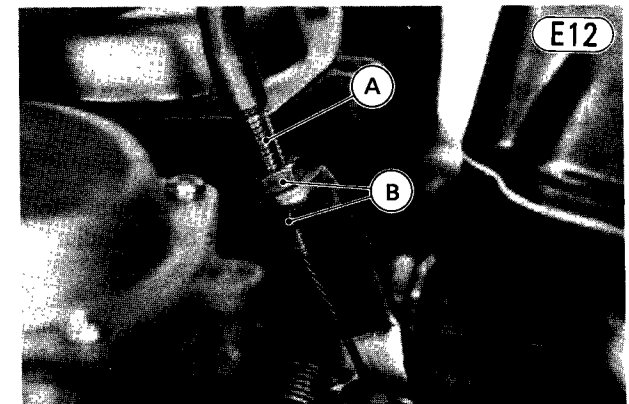

E12

46 DISASSEMBLY—ENGINE INSTALLED

- Pull the carburetor overflow tubes off the air cleaner housing.
- Slip the carburetors up and out of them to the right side, and slip the tip of the inner cable out of the pulley to complete the carburetor removal.

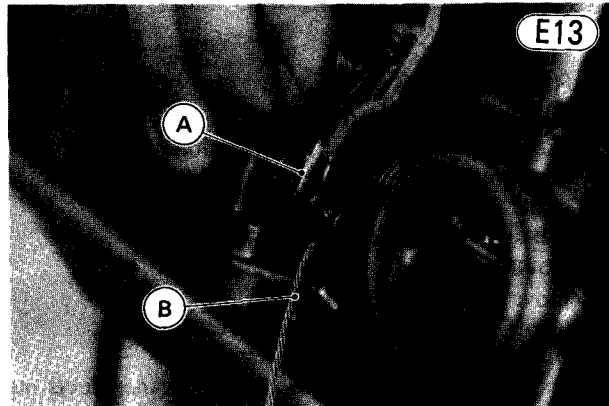

A. Pulley B. Inner Cable

Installation Notes:

1. If the carburetors were disassembled, visually synchronize the throttle (butterfly) valves as follows:
 - Check to see that all butterfly valves open and close smoothly without no binding when turning the pulley.
 - Visually check the clearance between the butterfly valve and the carburetor bore in each carburetors.

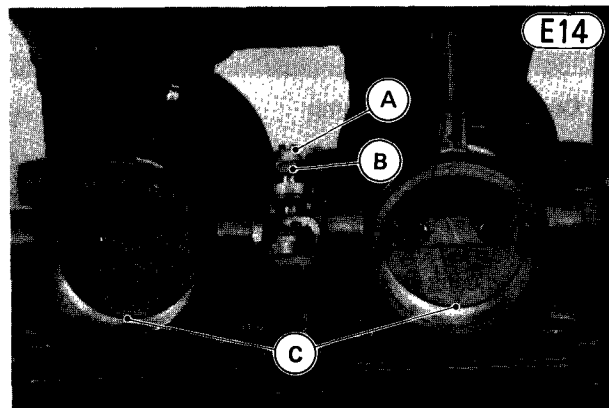

A. Balance Adjusting Screw B. Locknut C. Clearance

- If there is a difference between any two carburetors, loosen the locknut(s) and turn the balance adjusting screw(s) to obtain the same clearance.
 - Tighten the locknut(s).
2. Fit the carburetor holder clamps so that the left inner (#2) clamp opening points upwards and that the other clamp openings point downwards.
 3. Run the throttle cable between the right fork leg

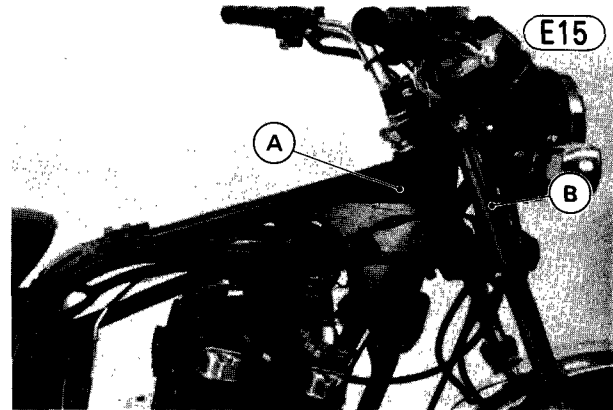

A. Throttle Cable B. Right Fork Leg

4. Run the carburetor overflow tubes into the air cleaner housing.

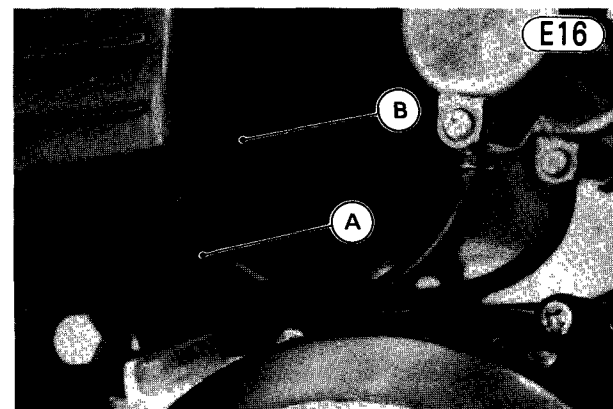

A. Overflow Tube B. Air Cleaner Housing

5. Adjust the throttle cable (Pg. 14).
6. Adjust the carburetors (Pg. 15).

Carburetor Body Disassembly (each carburetor):

NOTE: The following procedure explains removal of the carburetor parts listed below, and these parts can be removed without separating the carburetors from the mounting plates.

Vacuum Piston	Needle Jet Holder
Jet Needle	Float
Pilot Screw	Float Valve Needle
Primary Main Jet	Needle Jet
Main Jet Bleed Pipe	Pilot Jet
Secondary Main Jet	

Top End:

- Remove the upper chamber cover screws (53) (4), and take off the cover (54) and spring (55).

Carburetors

E17

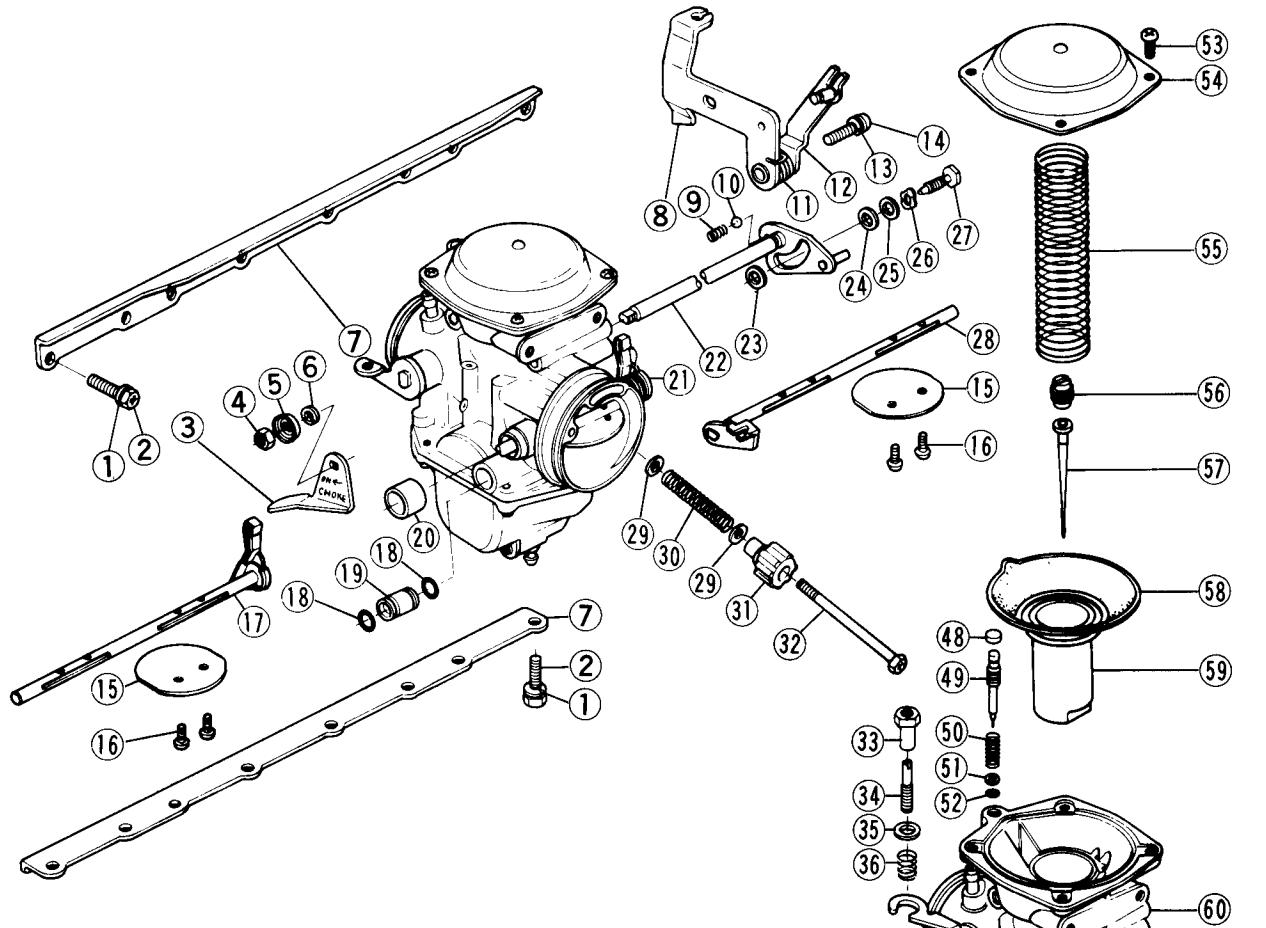

- | | | |
|----------------------|-----------------------------|-------------------------|
| 1. Lockwasher | 25. Flat Washer | 47. Screw |
| 2. Mounting Bolt | 26. Wave Washer | 48. Plug |
| 3. Choke Lever | 27. Bolt | 49. Pilot Screw |
| 4. Nut | 28. Right Choke Shaft | 50. Spring |
| 5. Washer | 29. Flat Washer | 51. Flat Washer |
| 6. Lockwasher | 30. Spring | 52. O Ring |
| 7. Mounting Plate | 31. Knob | 53. Screw |
| 8. Cable Bracket | 32. Idle Adjusting Screw | 54. Upper Chamber Cover |
| 9. Spring | 33. Locknut | 55. Spring |
| 10. Ball | 34. Balance Adjusting Screw | 56. Holding Screw |
| 11. Spring | 35. Flat Washer | 57. Jet Needle |
| 12. Fast Idle Link | 36. Spring | 58. Diaphragm |
| 13. Lockwasher | 37. Spring | 59. Vacuum Piston |
| 14. Screw | 38. Bleed Pipe | 60. Carburetor Body |
| 15. Choke Valve | 39. Primary Main Jet | 61. Needle Jet |
| 16. Screw | 40. Pilot Jet | 62. Needle Jet Holder |
| 17. Left Choke Shaft | 41. O Ring | 63. Float Valve Needle |
| 18. O Ring | 42. Plastic Plug | 64. Hanger Clip |
| 19. Joint | 43. Float | 65. Secondary Main Jet |
| 20. Seal | 44. O Ring | 66. Float Pin |
| 21. Spring | 45. Float Bowl | 67. Drain Screw |
| 22. Choke Link Shaft | | |
| 23. Flat Washer | | |

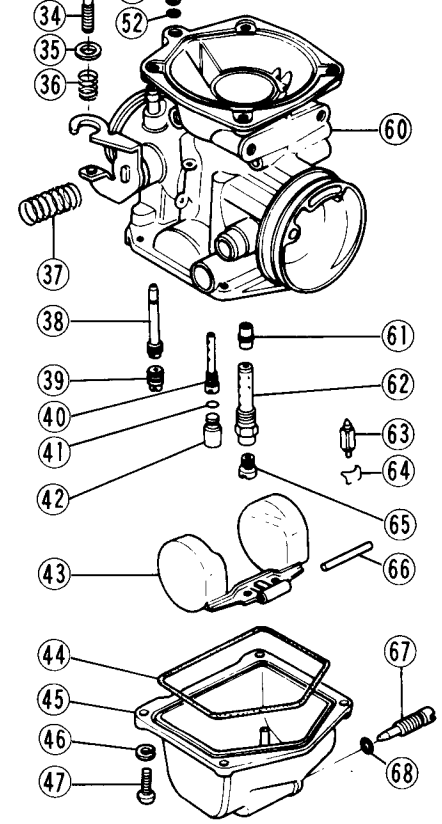

48 DISASSEMBLY—ENGINE INSTALLED

CAUTION During carburetor disassembly, be careful not to damage the diaphragm. Never use a sharp edge to remove the diaphragm.

- Unscrew the holder (56), and remove the jet needle (57).
- To remove the pilot screw (49) on the US model, punch and pry off the plug (48) with an awl or other suitable tools, turn in the pilot screw and count the number of turns until it seats fully but not tightly, and then remove the pilot screw, spring (50), washer (51), and O ring (52). This is to set the pilot screw on its original position when assembling.

Bottom End:

- Remove the screws (47) and lockwashers (46) (4 ea), and take off the float bowl (45) and O ring (44).
- Now the primary main jet (39), main jet bleed pipe (38), secondary main jet (65), and needle jet holder (62) can be removed.

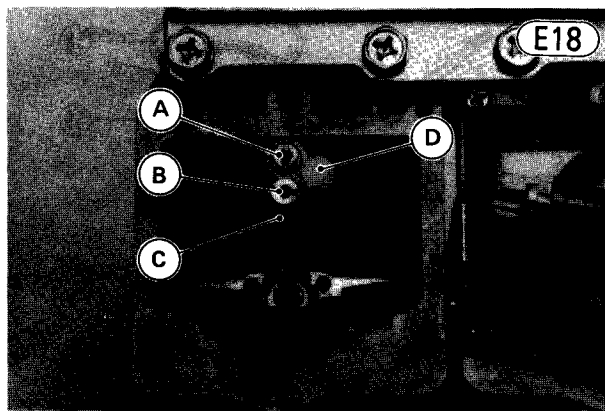

A. Primary Main Jet
B. Secondary Main Jet
C. Needle Jet Holder
D. Plastic Plug

- To remove the float valve needle (63), first push out the float pin (66), remove the float (43), and pull out the float valve needle with its hanger clip (64).
- To remove the needle jet (61), remove the vacuum piston (See Pg. 46) and needle jet holder (62).
- To remove the pilot jet (40), remove the plastic plug (42) with its O ring (41).

Carburetor Body Assembly Notes (each carburetor):

1. Replace any O ring and plastic plug if damaged or deteriorated.
2. Assemble the upper chamber as follows:
 - Insert the spring into the vacuum piston.
 - Fit the vacuum piston into the carburetor body, and check that the piston slides up and down without drag.
 - Align the diaphragm tongue with the notch in the upper chamber cover mating surface, and fit the

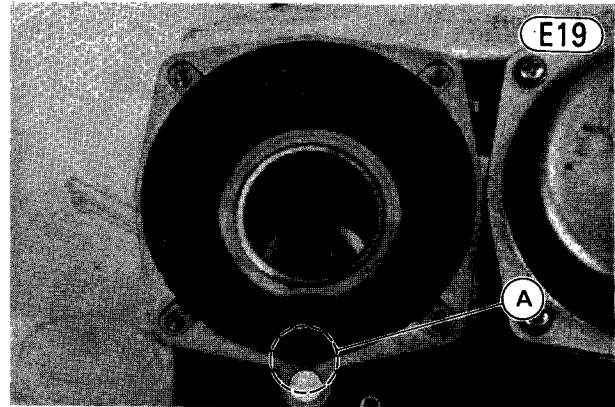

A. Align the tongue with the notch.

- With a finger, lift the vacuum piston just enough so that there is no crease on the diaphragm, and taking care not to pinch the diaphragm lip, install the upper chamber cover. While holding the cover to keep it from being lifted by the spring, tighten the screws (4).

CAUTION If the diaphragm is pinched, not only does the diaphragm become damaged, but the vacuum piston will not slide down to the rest position (there is a 7 mm space normally left between the piston lower end and the carburetor venturi). This causes idling instability and reduces engine performance.

- After installing the upper chamber cover, check that the vacuum pistons slide up and down smoothly without binding in the carburetor bores.
3. When assembling the float valve needle, hook its hanger clip to the tang on the float.

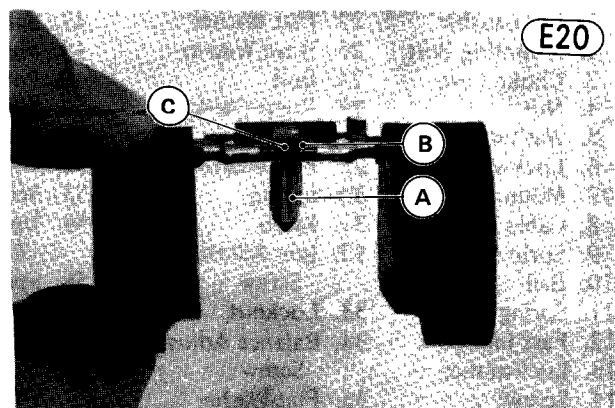

A. Valve Needle
B. Hanger Clip
C. Tang

4. For the US model, install the pilot screw and plug as follows:
 - Turn in the pilot screw fully but not tightly, and the back it out the same number of turns counted during disassembly.
 - Install a new plug in the pilot screw hole, and apply a small amount of a bonding agent to the circum-

DISASSEMBLY—ENGINE INSTALLED 49

Plug Installation

E21

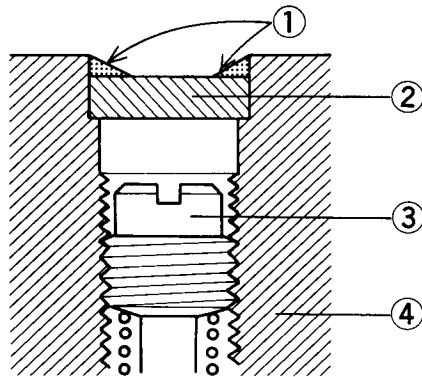

- | | |
|---------------------------|--------------------|
| 1. Apply a bonding agent. | 3. Pilot Screw |
| 2. Plug | 4. Carburetor Body |

CAUTION

Do not apply too much bond on the plug to keep the pilot screw itself from being fixed.

Separation of Carburetors:

NOTE: Be sure to have a choke shaft kit on hand prior to separate the carburetors.

- Unhook the end of the choke link spring (21) from the lever on the right choke shaft.

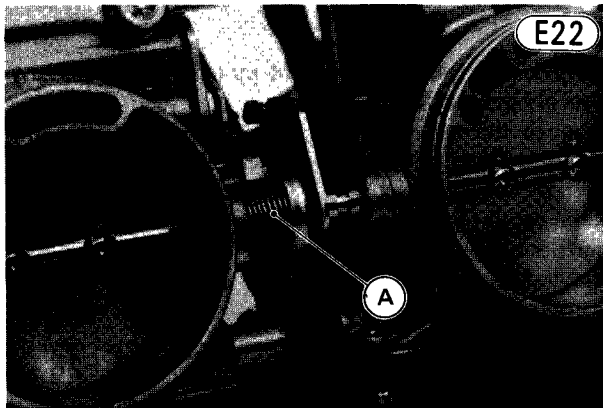

A. Choke Link Spring

- Remove the screws and lockwashers (8 ea) to take off the upper mounting plate (7).
- Remove the screws and lockwashers (8 ea) to take off the lower mounting plate, and separate the left carburetors (#1 and #2) and right carburetors (#3 and #4). The fuel hose 3-way joint comes off.
- To separate the left carburetors (#1 and #2), straighten the flat washer (5), and remove the nut (4), flat washer

- Remove the bolt (27), wave washer (26), flat washer (25), and plastic washer (24), and pull off the choke linkage shaft (22). The small steel ball (10) and spring (9) come off with the shaft.

- Remove the choke valve retaining screws (16), and take off the choke valves (15).

- Pull of the choke shaft (17), and separate the carburetors. The linkage mechanism spring (21) comes off.

Assembly Notes:

1. When installing the choke valve, new choke shaft and screws must be used for installation. Crimp new screws with an adapter enclosed in a choke shaft kit as shown.

Choke Valve Installation

E23

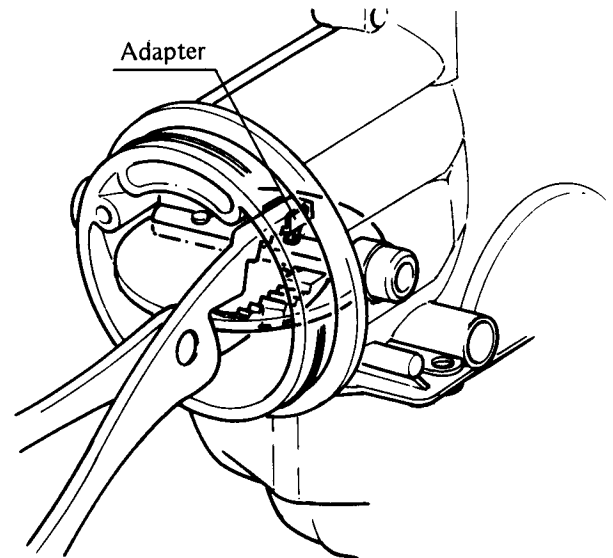

2. Check that the O rings (2) are in place, and install the long pipe of the fuel hose 3-way joint to the #3 carburetor.
3. Install the linkage mechanism spring as shown.

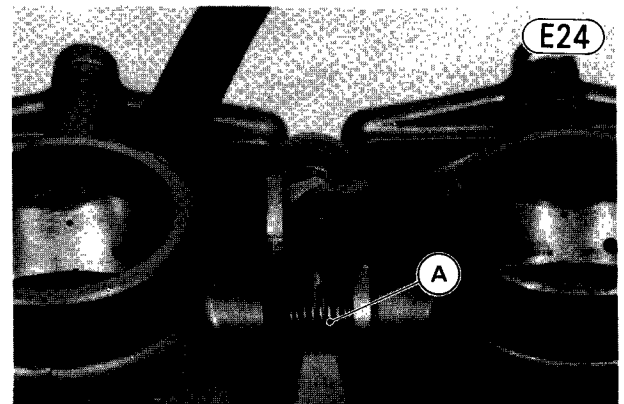

50 DISASSEMBLY—ENGINE INSTALLED

4. Hook the end of the choke link spring on the lever.
5. The centerlines of the carburetor bores must be parallel both horizontally and vertically. If they are not, loosen the mounting screws just enough so that the carburetors are able to move, align them on a flat surface, and retighten the mounting screws.

Fast Idle Mechanism Adjustment:

- Check that there is 4 ~ 6 mm clearance between the pin on the idling link and the fast idle cam when the choke lever is fully pushed down as shown in Fig. E25.

Fast Idle Mechanism

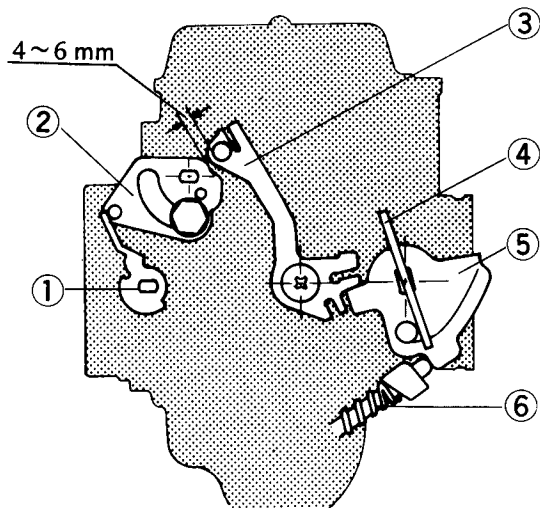

- | | |
|-------------------|-------------------------|
| 1. Choke Link | 4. Butterfly Valve |
| 2. Fast Idle Cam | 5. Pulley |
| 3. Fast Idle Link | 6. Idle Adjusting Screw |

- If the clearance is not within the specified valve, adjust the gap in the idling link to obtain the proper clearance.

MUFFLERS

Removal (each muffler):

- Loosen both clamps securing the muffler connecting pipe to the mufflers, and loosen the clamp securing the

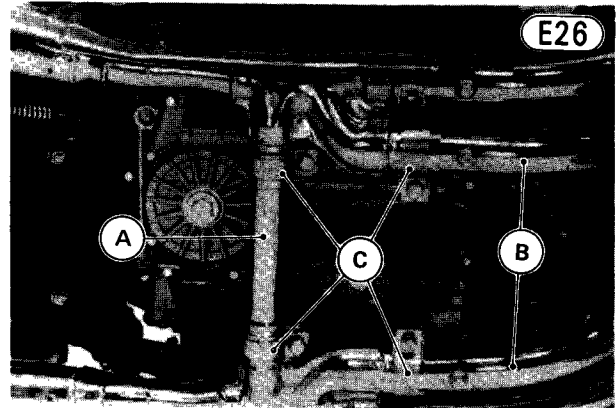

- | | |
|--------------------|-----------|
| A. Connecting Pipe | C. Clamps |
| B. Exhaust Pipes | |

- Remove the inner exhaust pipe holder nuts (2), and slide the holder off its cylinder head studs.

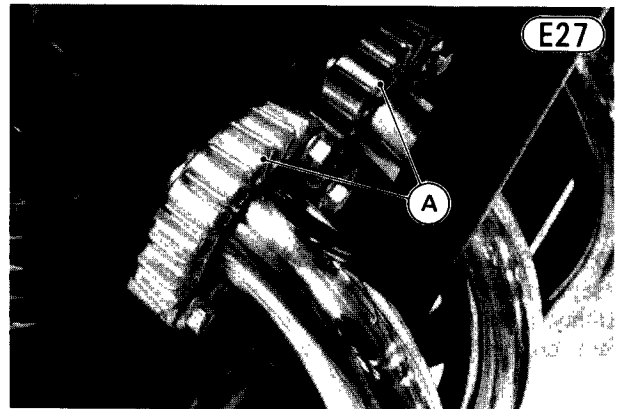

A. Exhaust Pipe Holders

- Remove the split keepers, and pull the inner exhaust pipe off the muffler.
- Remove the outer exhaust pipe holder nuts (2), and slide the holder off its cylinder head studs.
- Remove the split keepers.
- Remove the rear footpeg mounting bolt to complete muffler removal. Also, remove the exhaust pipe holders and gaskets.

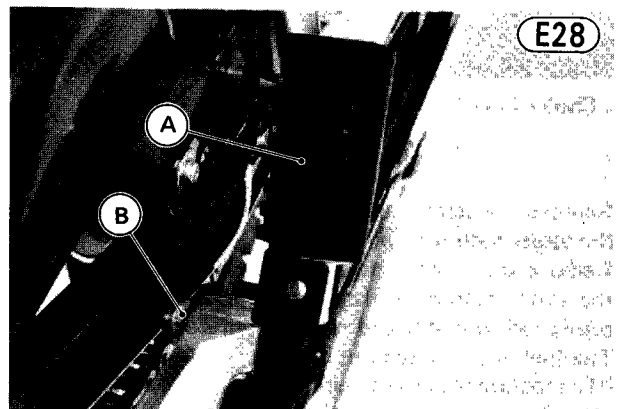

Installation (each muffler):

- Fit the connecting pipe and gasket to the muffler.
- Fit a gasket into each exhaust port, and place each pipe holder on the stud bolts.
- Fit the end of the exhaust pipe into the exhaust port, and attach the muffler to the frame with the rear footpeg mounting bolt finger tight.
- Fit the split keeper back into place, holding it in place with the exhaust pipe holder, tighten the holder nuts evenly to avoid an exhaust leak, and then tighten the rear footpeg mounting bolt.

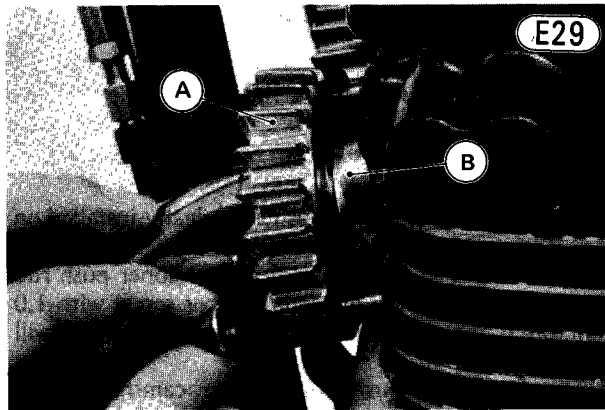

A. Exhaust Pipe Holder B. Split Keeper

- Fit the inner exhaust pipe into the exhaust port and into the muffler.

NOTE: There is an identification mark on the inner exhaust pipes. Do not mix up those exhaust pipes.

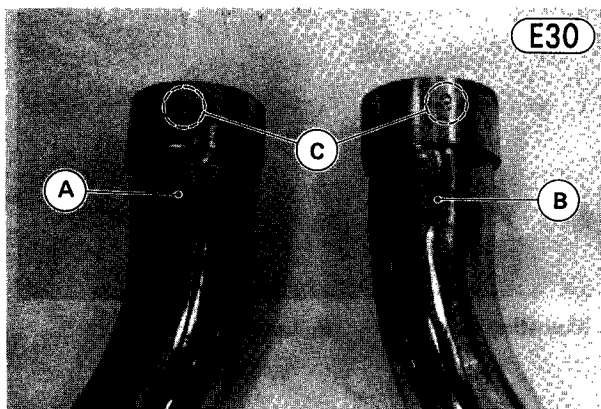

A. #2 Cylinder Exhaust Pipe C. Marks
B. #3 Cylinder Exhaust Pipe

- Fit the split keeper back into place, tighten the exhaust pipe holder nuts evenly, and then tighten the clamp bolt.
- Tighten the rear footpeg mounting bolt.
- Thoroughly warm up the engine, wait until the engine grows cold, and tighten all the clamp bolts.
- Tighten the clamp bolts of the muffler connecting

IGNITION COILS

Removal (each ignition coil):

- Remove the fuel tank (Pg. 43).
- Pull the spark plug lead from each spark plug.
- Disconnect the black or green lead, and red lead of the ignition coil.
- Remove the bolts (2) to take off the ignition coil.

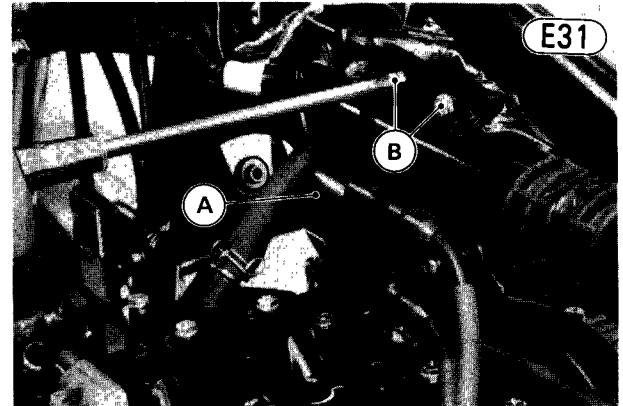

A. Ignition Coil B. Bolts

Installation (each ignition coil):

NOTE: Install the ignition coil (#1, 4) under the right bracket and the ignition coil (#2, 3) under the left bracket.

- Install the ignition coils so that the spark plug leads point to the rear.
 - Connect the spark plug lead to each spark plug.
 - Connect the ignition coil leads (green or black, red).
- NOTE:** Connect the green and black leads as following:
Green Lead ↔ Ignition Coil (#2, 3)
Black Lead ↔ Ignition Coil (#1, 4)

**VACUUM SWITCH VALVE, SILENCER
(on US Model)**

Removal:

- Remove the fuel tank (Pg. 43).
- Remove the ignition coils.
- Slide the clamp out of place, and pull the air hose off each air suction valve cover.

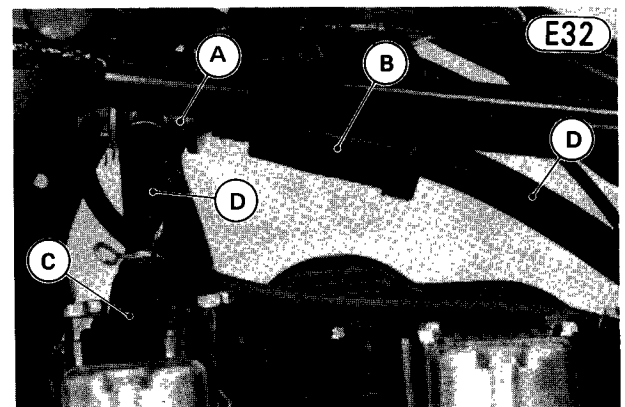

A. Vacuum Switch Valve C. Air Suction Valve Cover

52 DISASSEMBLY—ENGINE INSTALLED

- Pull the air hose off the air cleaner housing.
- Slide the clamp out of place, and pull the vacuum hose off #1 and #4 carburetors.
- Pull the vacuum switch valve with the hoses attached free off the motorcycle.

Installation Note:

- Check that all hoses fit in place, and that all clamps are installed.

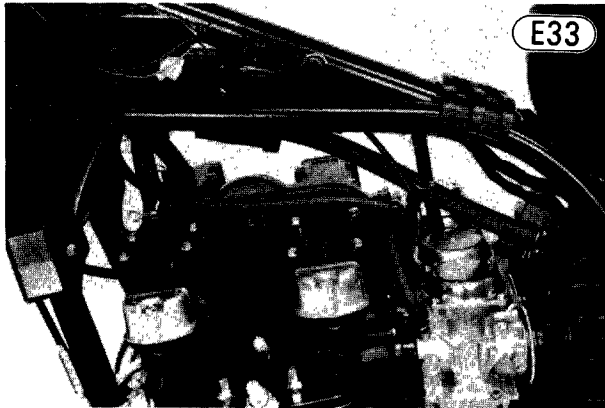

AIR SUCTION VALVES (on US Model)

Removal (either side):

- Remove the fuel tank (Pg. 43).
- Remove the air suction valve cover bolts, and lift the cover off the air suction valve assembly.
- Remove the valve assembly taking care not to damage the valve reeds and reed contact areas. If the valve assembly sticks in the cylinder head cover, pull it up by grasping the projection with pliers.

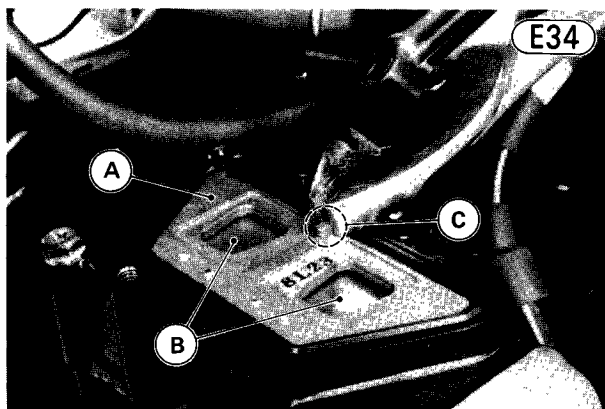

A. Valve Assembly

C. Projection

Installation Notes (either side):

1. Check the air suction valve assembly, and replace it with a new one if it is damaged (Pg. 167).
2. Tighten the cover bolts (4) to 0.80 kg-m (69 in-lbs) of torque with a flat washer installed under each bolt head.

CAMSHAFT CHAIN TENSIONER

Removal:

- Remove the fuel tank (Pg. 43).
- Remove the carburetors (Pg. 45).
- Remove the lock bolt and washer originally installed on the tensioner, and then turn in and tighten securely a longer 110B0616 bolt to hold the tensioner push rod in place. (Any 6 mm diameter bolt or screw with 1.0 mm pitch threads about 16 mm long or longer will work.)

NOTE: Once the push rod in the camshaft chain tensioner moves out to take up chain slack automatically, it does not return to its original position. So, lock the tensioner before starting any disassembly operation that slackens the chain: camshaft removal, etc.

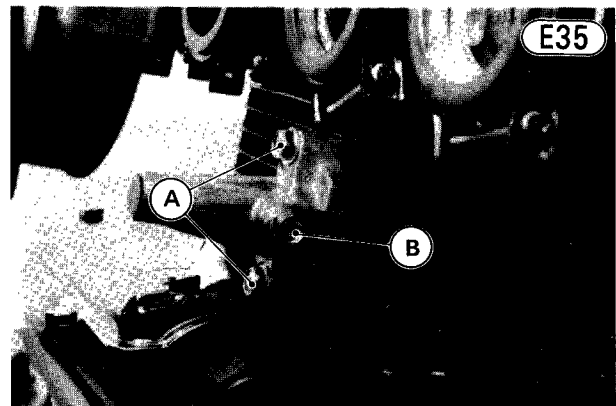

A. Mounting Bolts

B. Lock Bolt

- Remove the chain tensioner mounting bolts (2), and take off the chain tensioner. The upper mounting bolt has an aluminum washer.

CAUTION When removing the chain tensioner, do not take out a mounting bolt only half-way. Retightening the mounting bolts from this position could damage the chain tensioner and the camshaft chain.

Installation:

- Remove the lock bolt, and take out the push rod. push

- Compressing the spring against the push rod head, insert a thin wire through the hole in the push rod to keep the spring in place.

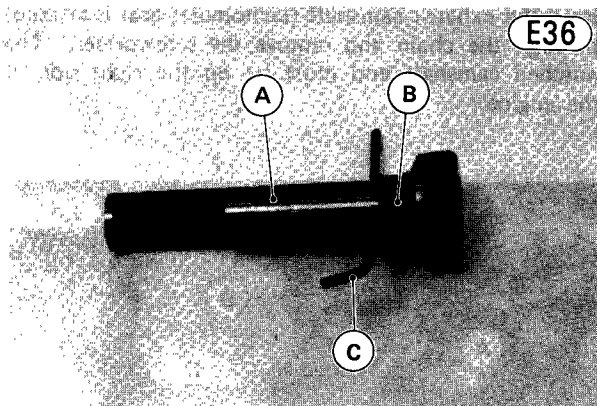

A. Push Rod B. Spring C. Wire

- Check to see that the stiff spring is in the tensioner body.
- Apply a thin coat of grease on the end of the push rod, and fit the push rod stop on the push rod so that the push rod stop is properly installed in the tensioner body as shown in Fig. E37.
- Insert the push rod stop into the tensioner body going through the ball retainer. And then hold the tensioner body with the open end down so that the balls will fall away from the ramp inside the tensioner and allow the push rod to go in. Keep the flat side of the push rod toward the lock bolt, and push in the rod by hand until the wire rests against the tensioner mating surface.
- Holding the push rod in position and facing the flat side toward the bolt, tighten the original lock bolt securely to prevent the push rod from sticking out, and then pull out the wire.

Camshaft Chain Tensioner

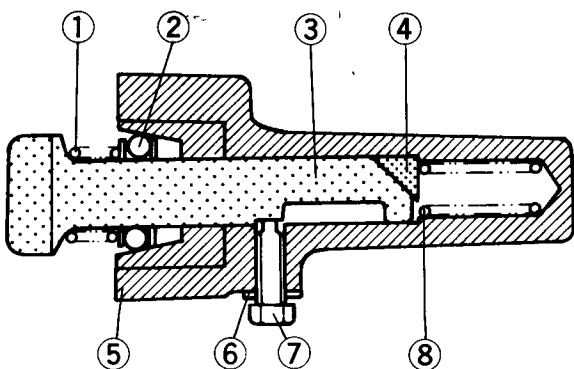

- | | |
|----------------------|----------------------|
| 1. Spring | 5. Tensioner Body |
| 2. Ball and Retainer | 6. Flat Washer |
| 3. Push Rod | 7. Lock Bolt |
| | 8. Ball and Retainer |

- Check the gasket, and replace it if it is damaged.
- Install the chain tensioner on the cylinder block, and tighten the mounting bolts. The upper mounting bolt is longer than the lower, and has an aluminum washer.
- Be certain that either the #1 and #4, or the #2 and #3 pistons are at TDC. If they are not, turn the crankshaft clockwise, and align one of the "T" marks on the timing advancer with the timing mark.
- Loosen the lock bolt and then tighten it. With the bolt loose, the stiff spring inside takes up any slack automatically.
- Install the carburetors (Pg. 46).
- Install the fuel tank (Pg. 43).

CAMSHAFTS

Removal:

- Remove the fuel tank (Pg. 43).
- Remove the ignition coils (Pg. 51).
- Remove the vacuum switch valve and silencer (on US model: Pg. 51).
- Remove the pick-up coil cover and gasket.
- Using a 17 mm wrench on the crankshaft, set the 1, 4 pistons at TDC by aligning the timing advancer "T" mark on the 1, 4 side (the line adjoining the "T") with the timing mark.

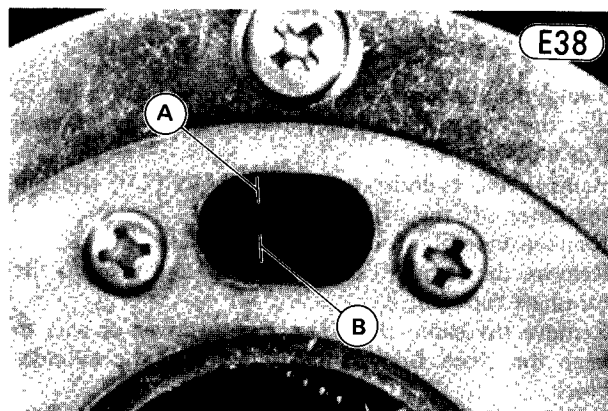

A. Timing Mark B. "T" Mark

- Remove the Allen bolt, and remove the tachometer pinion holder stops. Pull the tachometer pinion holder and pinion with the tachometer cable off the cylinder head.

CAUTION Attempting to install the camshafts with the tachometer pinion left in the cylinder

54 DISASSEMBLY—ENGINE INSTALLED

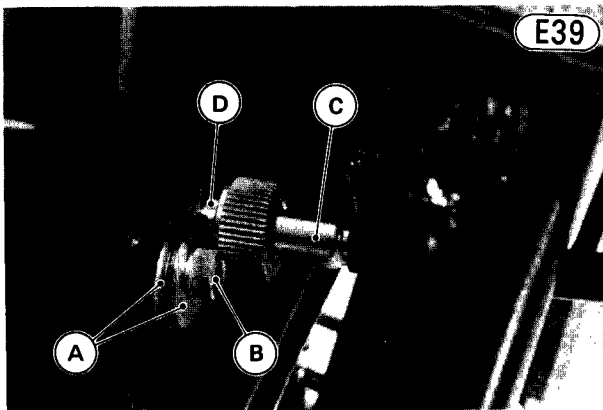

A. Holder Stops **C. Tachometer Cable**
B. Allen Bolt **D. Pinion Holder**

- Lock the chain tensioner (Pg. 52).
- Slide the hose clamps (2), and pull the hoses (2) off the air suction valve covers (US model).

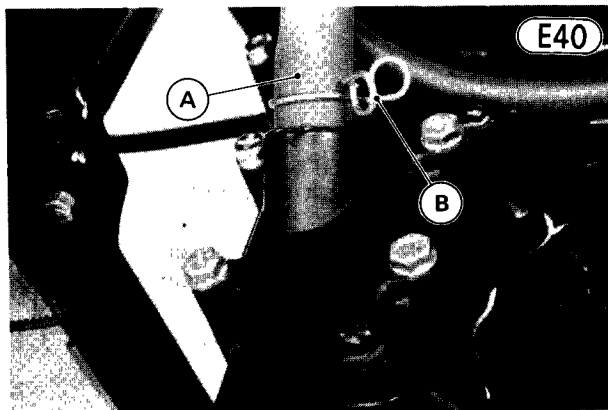

A. Hose **B. Hose Clamp**

- Swing the vacuum switch valve and silencer aside so that they do not binder cylinder head cover removal (US model).
- Remove the cylinder head cover bolts (24), and slip the cover off the cylinder head.
- Remove the cylinder head cover gasket.
- Remove the camshaft cap bolts (16), and take off the camshaft caps (8).
- Remove the camshafts. Use a screwdriver or wire to keep the chain from falling down into the cylinder block.

CAUTION Always pull the camshaft chain taut while turning the crankshaft with the camshaft chain loose. This avoids kinking the chain on the lower (crankshaft) sprocket. A kinked chain could damage both the chain and the sprocket.

Installation:

- Check that the tachometer pinion is removed from the cylinder head and all camshaft cap knock pins

- Check crankshaft position to see that the 1, 4 pistons are still at TDC, and readjust if necessary. Remember to pull the camshaft chain taut before rotating the crankshaft.
- Apply clean engine oil to all cam parts.
- Feed the exhaust camshaft (tachometer gear is affixed) through the chain and remove the screwdriver. The notched camshaft end must be on the right side of the engine.

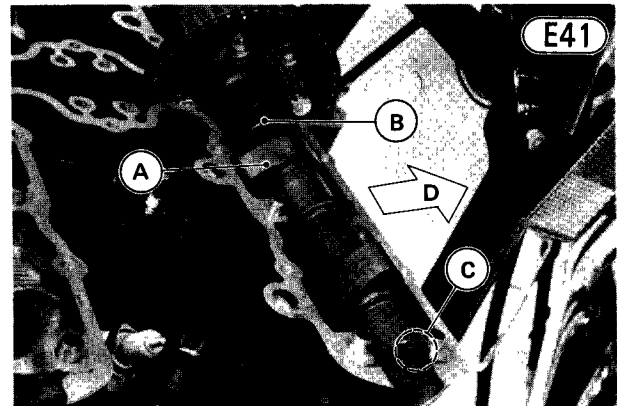

A. Exhaust Camshaft **C. Notch**
B. Tachometer Gear **D. Front**

- Turn the exhaust camshaft so that the line adjoining the Z7EX mark on the sprocket is pointing to the front aligned with the cylinder head surface.
- Pull the chain taut and fit it onto the exhaust camshaft sprocket.

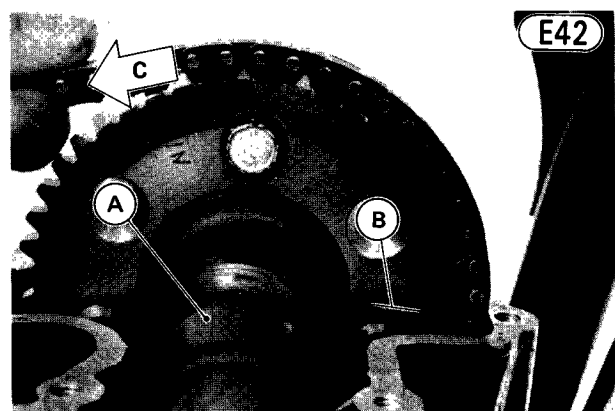

A. Exhaust Camshaft **B. Line** **C. Pull**

- Feed the inlet camshaft through the chain, and align the line adjoining the IN mark on the sprocket with the cylinder head surface and pointing to the rear. Find the pin on the link pointed at by the exhaust camshaft sprocket line adjoining the Z7EX mark, starting with this pin as zero (0), count to the 45th pin. Check to see that the inlet camshaft sprocket line adjoining the IN mark points between that 45th and

DISASSEMBLY—ENGINE INSTALLED 55

E43

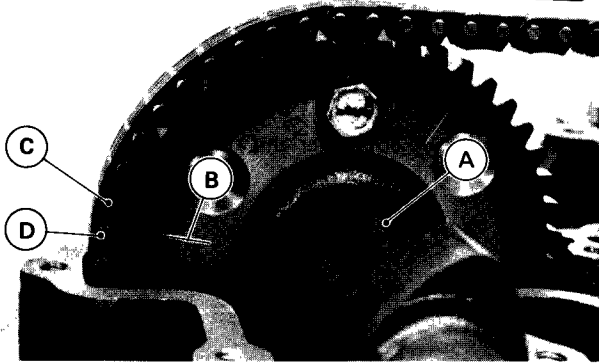

A. Inlet Camshaft
B. Line
C. 45th Pin
D. 46th Pin

- Check that the camshaft chain seats in the groove of the front and rear chain guides.
- The camshaft caps are machined together with the cylinder head, so match the number on the camshaft caps with the number on the cylinder head. The arrow on the cap points forward (toward the exhaust).

E44

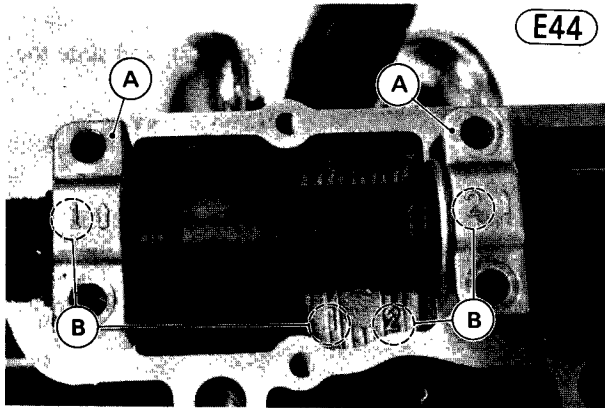

A. Camshaft Cap
B. Match the number.

Camshaft Chain Timing

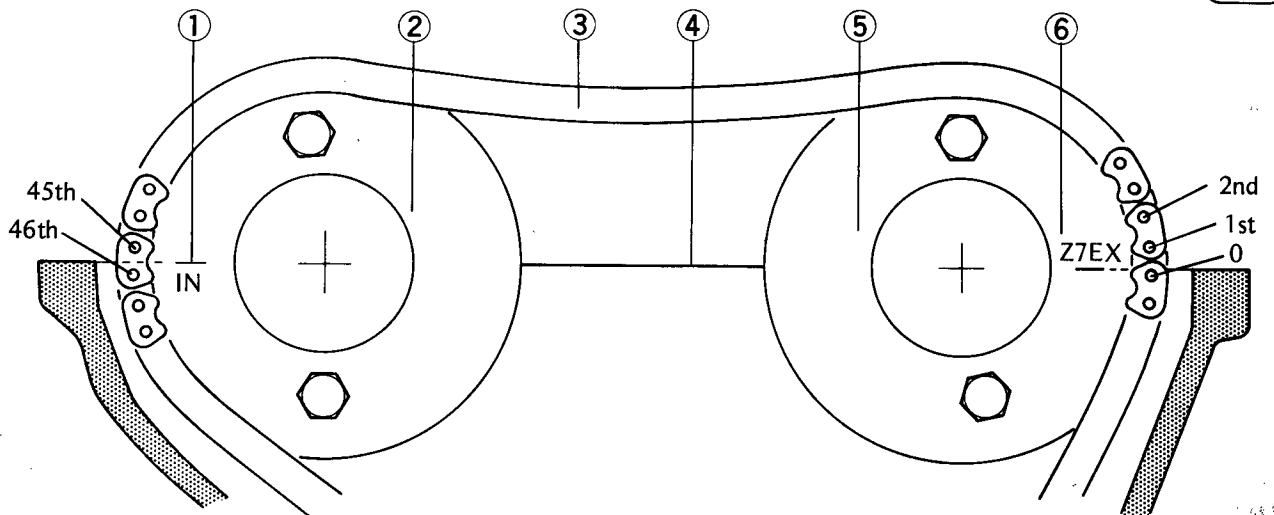

1. "IN" Mark
2. Inlet Camshaft Sprocket

4. Cylinder Head Upper Surface
5. Exhaust Camshaft Sprocket

- Partially tighten the left inside camshaft cap bolts first, to seat the camshaft in place. Fully tighten all the bolts to 1.2 kg-m (104 in-lbs) of torque, following the tightening sequence shown in the figure.

Camshaft Cap Tightening Order

E45

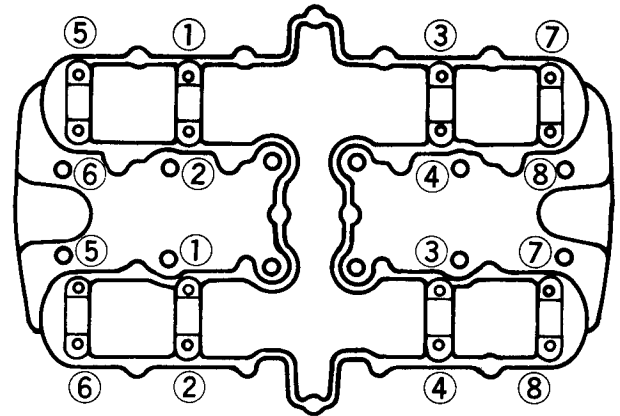

- With the crankshaft positioned so #1 and #4 pistons are at TDC, check that the timing marks on the exhaust and inlet camshaft sprockets are aligned with the cylinder head surface.

CAUTION Rotation of the crankshaft with improper camshaft timing could cause the valves to contact each other or the piston, and bend.

NOTE: If a new camshaft, cylinder head, valve or valve lifter was installed, check valve clearance at this time (Pg. 12), and adjust if necessary.

- Apply a small amount of molybdenum disulfide engine assembly grease to the tachometer pinion shaft, insert the pinion and pinion holder into the cylinder head (Fig. E47).

E46

56 DISASSEMBLY—ENGINE INSTALLED

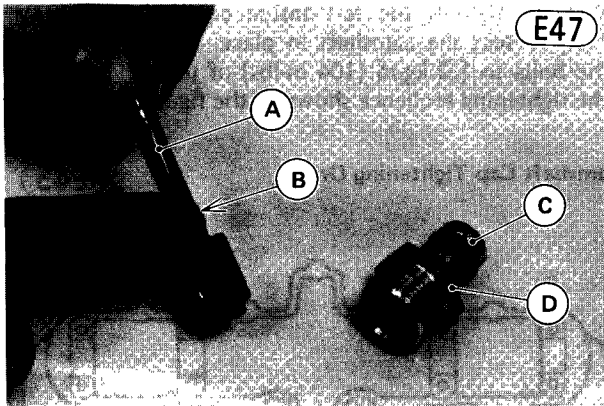

A. Pinion Shaft
B. Grease
C. "O" Ring
D. Pinion Holder

- Install the pinion holder stops, and tighten the holder stop Allen bolt.
- Replace the cylinder head rubber plugs with new ones, apply a liquid gasket to the circumference of each rubber plug, and fit them in place.

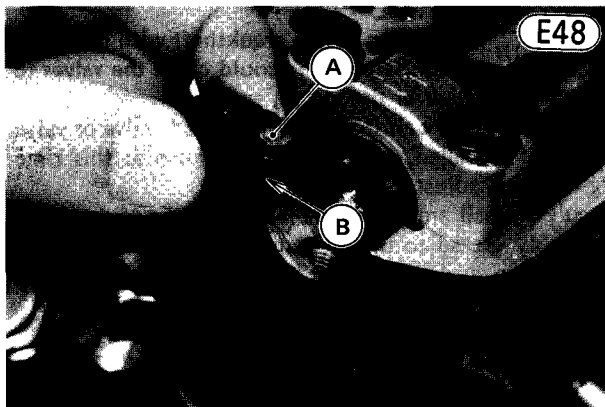

A. Rubber Plug
B. Apply a liquid gasket.

- Install the cylinder head cover with a new cylinder head cover gasket. The arrow on the cover must point toward the front. Tighten the cover bolts (24) to 0.8 kg-m (69 in-lbs) of torque.
- Remove the chain tensioner locking bolt (screw), and tighten the original bolt with a flat washer.
- Turn the crankshaft over clockwise.

- CAUTION**
1. If any resistance is felt when turning over the crankshaft, stop immediately, and check the camshaft chain timing. Valves may be bent, if the timing was not properly set.
 2. Do not try to turn the crankshaft and camshafts with a wrench on the camshaft sprocket. Use a 17 mm wrench on the end of the crankshaft.
- Fit the air hoses onto the air suction valve covers

- Check to see that the air and vacuum hoses are connected firmly to the air cleaner housing, air suction valves, and carburetors. Each hose end should be secured by a hose clamp (US model).
- Install the ignition coils (Pg. 51).
- Install the fuel tank (Pg. 43).
- Install the pick-up coil cover and gasket.

CAMSHAFT SPROCKETS

Removal (on each camshaft):

- Remove the camshaft (Pg. 53).
- Remove the camshaft sprocket bolts (2), and slide the sprocket off the camshaft.

Installation:

- Set the sprocket on the camshaft, aligning the bolt holes. Use the two of six sprocket bolt holes for installation as shown. The marked side of the camshaft sprocket must face the notch on the shaft end.

Camshaft Sprocket Installation

E49

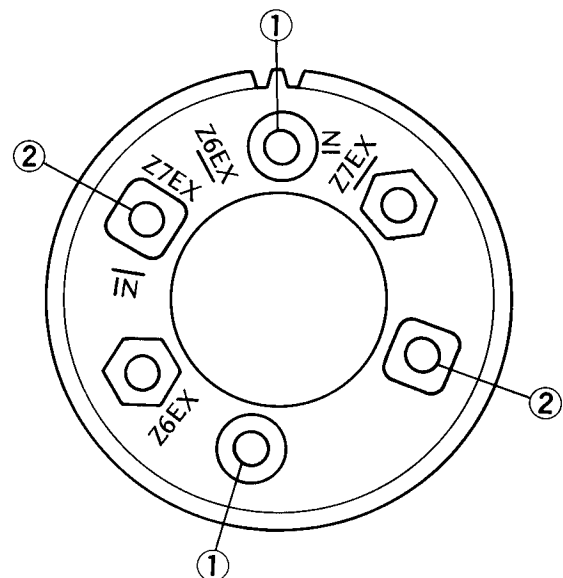

1 Bolt Hole for Inlet Camshaft

DISASSEMBLY—ENGINE INSTALLED 57

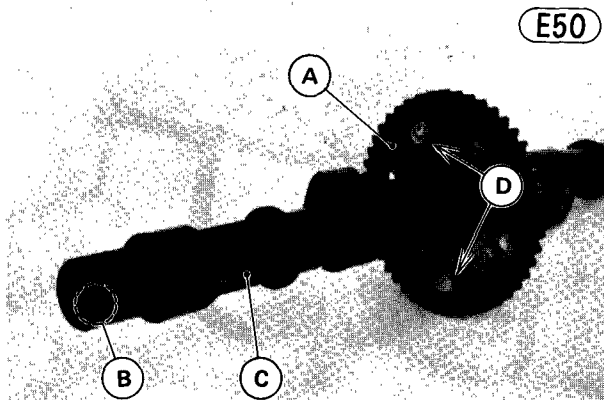

A. Sprocket **B. Notch** **C. Camshaft**
D. Apply a non-permanent locking agent.

- Apply a non-permanent locking agent to the sprocket bolts (2) and install the bolts, tightening them to 1.5 kg-m (11.0 ft-lbs) of torque.
- Install the camshafts (Pg. 54).

CYLINDER HEAD

Removal:

- Remove the mufflers (Pg. 50).
- Remove the carburetors (Pg. 45).
- Remove the camshafts (Pg. 53).
- Remove the cylinder head bolts (2) and nuts (12) from the upper cylinder head.

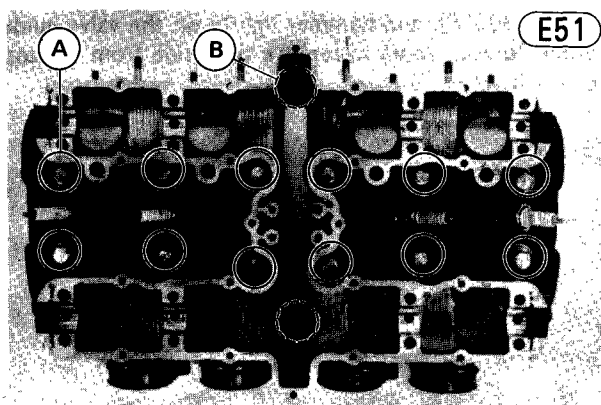

A. Cylinder Head Nuts **B. Cylinder Head Bolts**

- Pull off the cylinder head, and remove the cylinder

Installation:

NOTE: The camshaft caps are machined together with the cylinder head, so, if a new cylinder head is installed, use the caps that are supplied with the new head.

- Using compressed air, blow out any particles which may obstruct the oil passages.
- Check that the orifices (2) are in place.
- Install new O rings.
- Be sure that the knock pins (2) are in place.

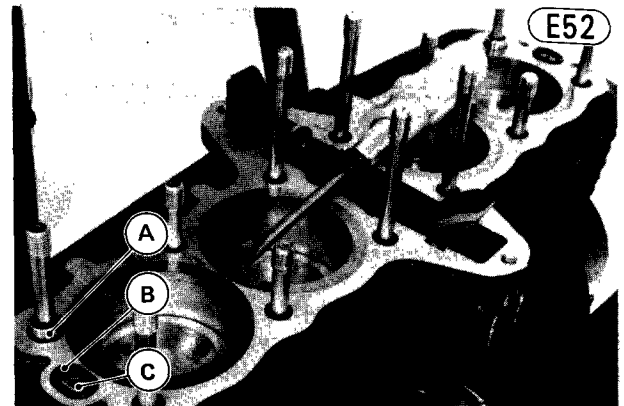

A. Knock Pin **B. "O" Ring** **C. Orifice**

- Apply a liquid gasket to the upper and lower gasket surfaces in the areas shown in Fig. E53, and install the gasket.

Liquid Gasket Applied Areas

E53

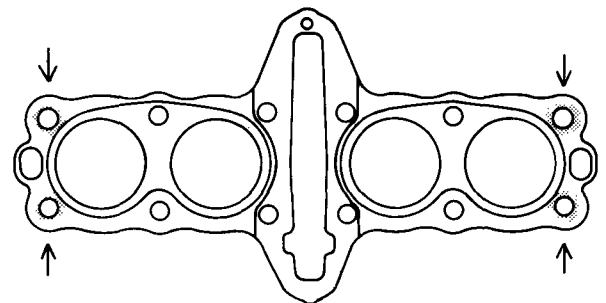

- Install the cylinder head.
- Lift up the camshaft chain, and use a screwdriver to keep the chain from falling down into the cylinder block.
- Tighten the cylinder head nuts (12) first to about 2.4 kg-m (18.0 ft-lbs) and finally to 4.0 kg-m (29 ft-lbs) of torque, following the tightening sequence shown in

58 DISASSEMBLY—ENGINE INSTALLED

Cylinder Head Tightening Order

E54

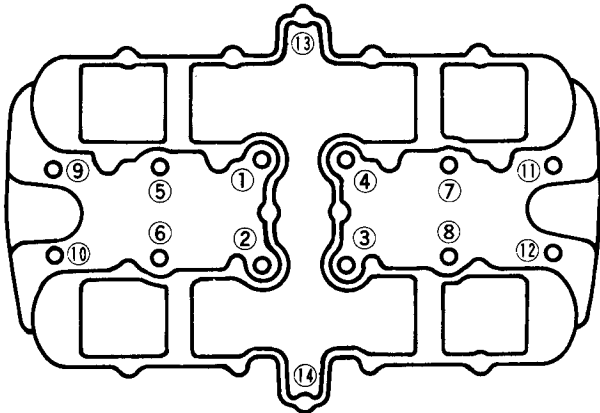

- Tighten the cylinder head bolts (2) to 3.0 kg-m (22 ft-lbs) of torque.
- Install the camshafts (Pg. 54).
- NOTE:** If a new camshaft, cylinder head, valve, or valve lifter was installed, check valve clearance (Pg. 12), and adjust if necessary.
- Install the carburetors (Pg. 46).
- Install the mufflers (Pg. 51).
- Adjust the throttle cable play (Pg. 14).
- Check the idling and adjust the carburetors if necessary (Pg. 15).
- Thoroughly warm up the engine, wait until the engine grows cold, and retighten the cylinder head nuts (12) to 4.0 kg-m (29 ft-lbs) of torque (Fig. E54).

WARNING To avoid serious burn, never touch the engine or exhaust pipes while they are hot.

VALVES, VALVE GUIDES

Removal (each valve and valve guide):

- Remove the cylinder head (Pg. 57).
- Pull out the valve lifters (8) and shims (8) with a suitable tool, marking them as to location.
- NOTE:** If more than one valve is to be removed, mark them as to location so they can be reinstalled in the proper place.
- Using the valve spring compressor assembly and adapter (special tools) to press down the valve spring retainer

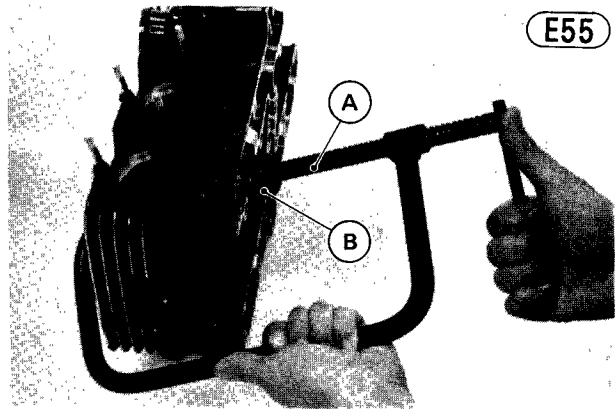

A. Valve Spring Compressor Assembly (57001-241)
B. Adapter (57001-243)

- Remove the tool, and then remove the spring retainer, outer spring (5), and inner spring (6).
- Push out the valve (12) or (13).
- Remove the oil seal (8) and spring band (7).

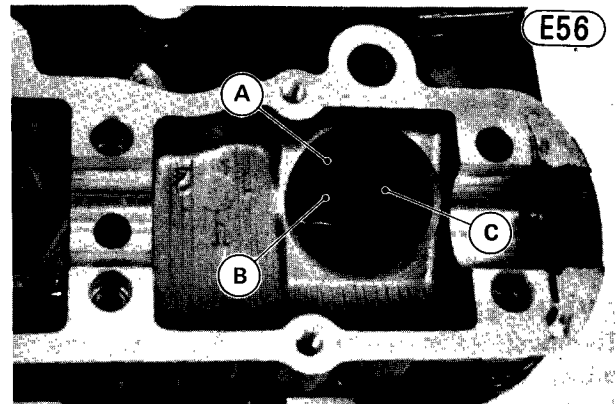

A. Spring Band
B. Oil Seal
C. Spring Seat

- Remove the spring seat (9).
- Heat the area around the guide (11) to about 120~150°C (248~302°F), and hammer lightly on the valve guide arbor (special tool) to remove the guide from the top of the head.

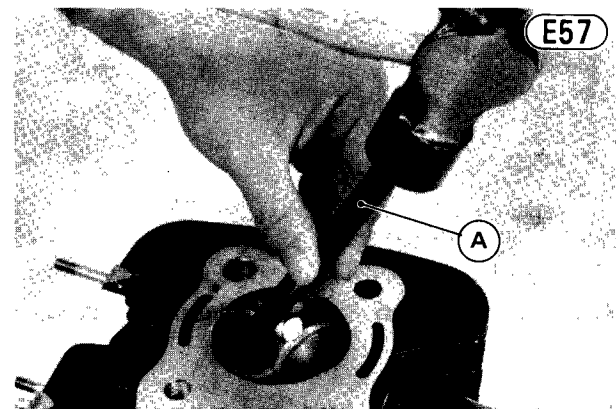

E57

Valve and Valve Guide

E58

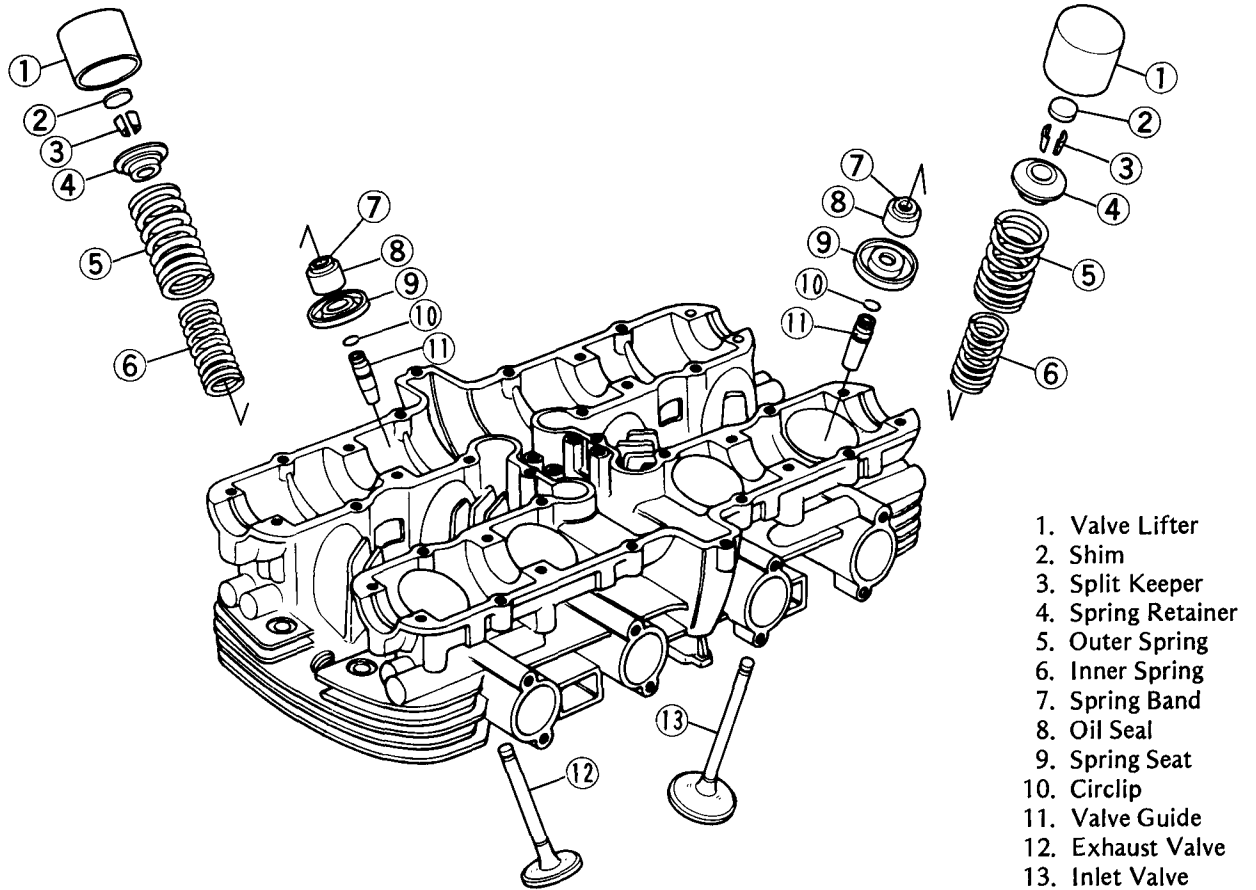

Installation (each valve and valve guide):

NOTE: If a new valve or valve guide are installed, check the valve/valve guide clearance (Pg. 163).

- Apply oil to the valve guide, and snap the circlip¹⁰ into the groove on the valve guide.
- Heat the area around the valve guide hole to about 120 ~ 150°C (248 ~ 302°F), and drive the valve guide in from the top of the head using the valve guide arbor (special tool). The circlip stops the guide from going in too far.
- Ream the valve guide with the valve guide reamer (special tool) even if the old guide is re-used.

- Lap the valve to check that it is seating properly. If it is uneven, refer to the Maintenance Section (Pg. 163).
- Push a new oil seal into place.
- Apply a thin coat of a molybdenum disulfide engine assembly grease to the valve stem, insert the valve, and install the outer and inner springs with the concentrated portion of each spring down as shown.

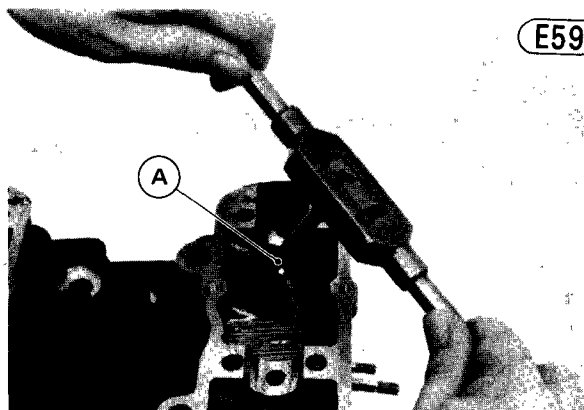

E59

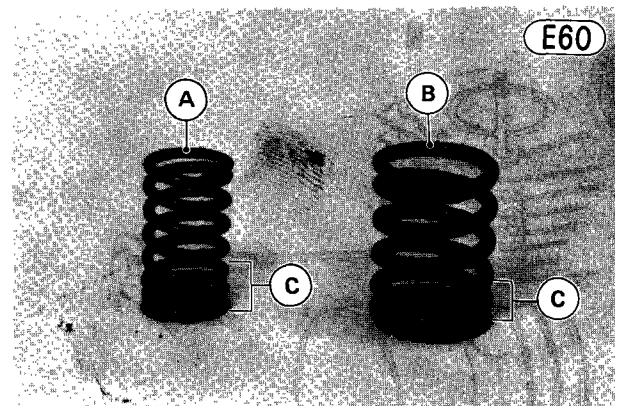

E60

A. Inner Spring B. Outer Spring
C. Concentrated Portion

- Install the spring retainer, press it down with the valve spring compressor assembly, and put on the

60 DISASSEMBLY—ENGINE INSTALLED

- After making sure that the split keeper, spring retainer, and valve stem are all properly fitted, remove the valve spring compressor assembly.
- Mount the shims and valve lifters in their original locations.
- Install the cylinder head (Pg. 57).
- Check valve clearance (Pg. 12), and adjust if necessary.

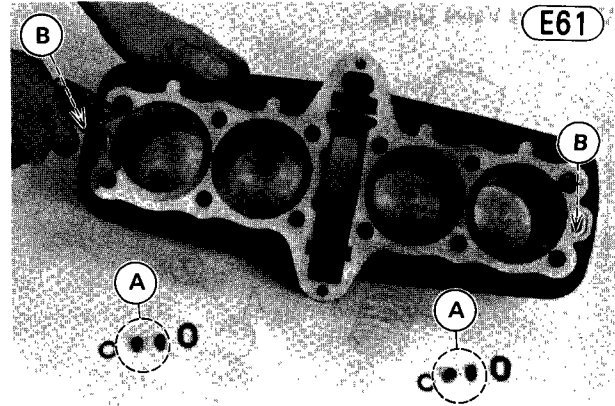

A. Orifices B. Compressed Air

CYLINDER BLOCK

Removal:

- Remove the cylinder head, gasket, and O rings (Pg. 57).
- With a large screwdriver, pry at the gap in each side of the cylinder base to free the cylinder block from the crankcase, and lift off the cylinder.

CAUTION Do not hammer on the screwdriver while it is in the pry point as engine damage could result (Fig. E63).

- Wrap a clean cloth around the base of each piston so that no parts or dirt will fall into the crankcase.

Installation:

NOTE: If the cylinder block is replaced with a new one, piston to cylinder clearance must be checked against the specified value (Pg. 170).

- With compressed air, blow out the oil passages and orifices to remove dirt or particles which may obstruct oil flow.

- Remove the cloth from under each piston.
- Install the oil passage orifices (2) so that the small hole in each orifice faces up. Install the new orifice O rings (2).

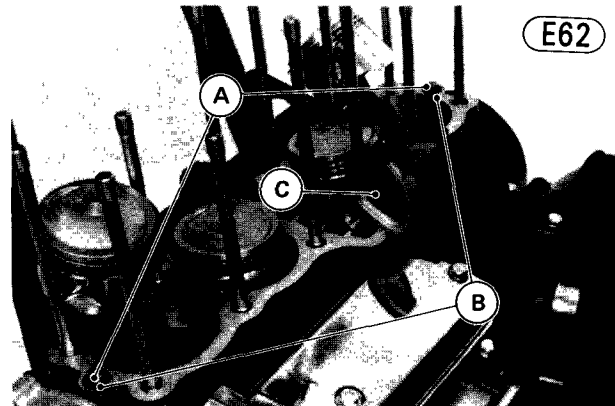

A. Orifices C. Rear Chain Guide
B. "O" Rings

Cylinder Block Pry Point

E63

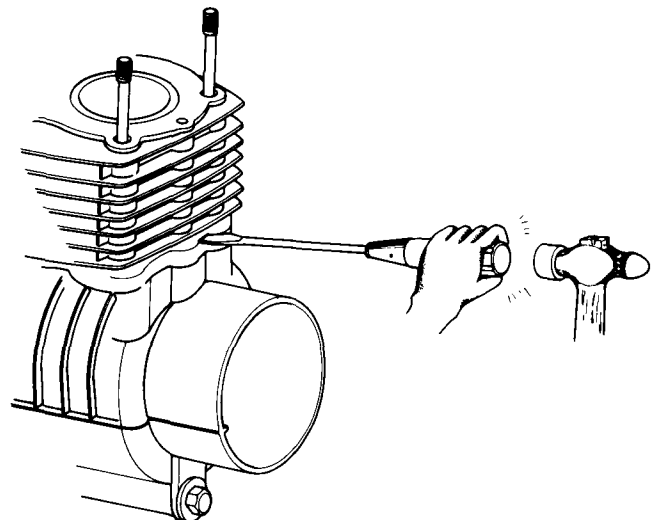
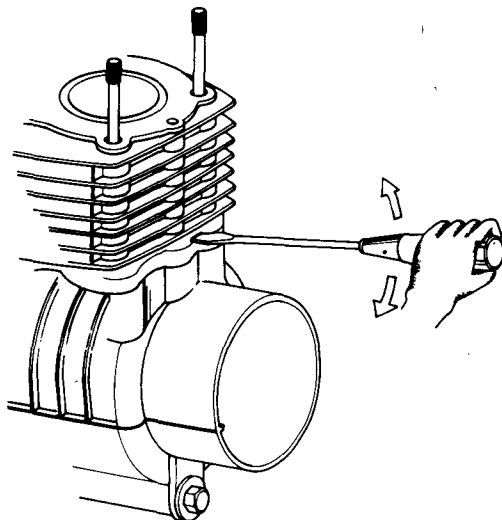

- Check that the rear chain guide is in place.
- Apply a liquid gasket to the upper and lower gasket surfaces in the area shown in Fig. E64, and install the gasket.

Liquid Gasket Applied Area

E64

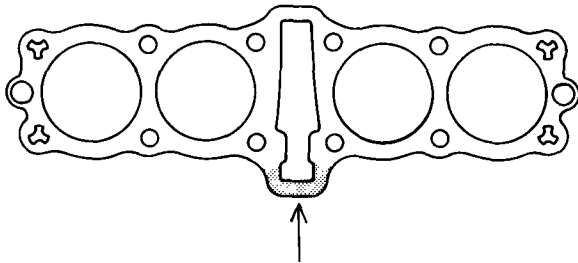

- Pull the chain taut to avoid kinking the chain, and using a 17 mm wrench on the crankshaft, turn the crankshaft so that all the pistons are at about the same height.
- Slip the piston bases (special tools) under the pistons to hold them level.

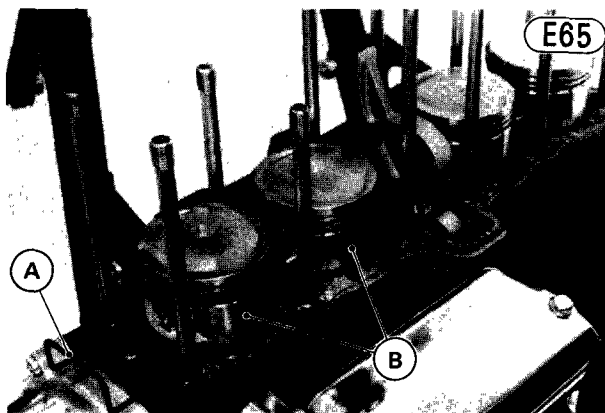

A. Piston Base (57001-149)

B. Pistons

- Position each piston ring so that the opening in the top and oil ring of each piston is facing forwards, and the second ring opening faces the rear. The openings of the oil ring steel rails must be slipped to both directions about 30° from the opening of the expander. (This last step is unnecessary if the motorcycle is provided with a

Piston Ring Openings

E66

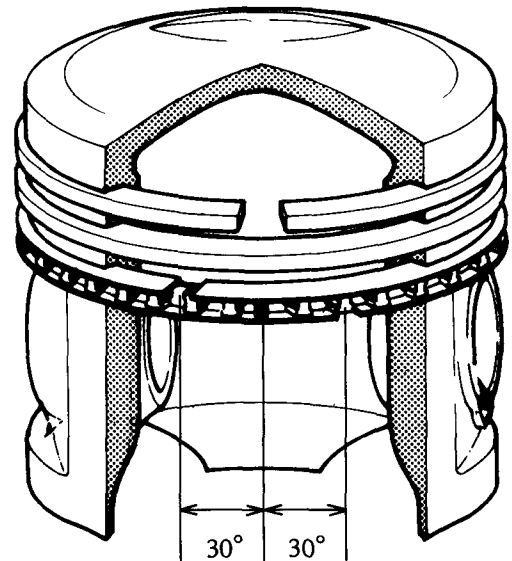

- Apply engine oil to the piston rings and the inside cylinder surfaces.
- Compress the piston rings using the piston ring compressor grip and adapter (special tools) on each piston.

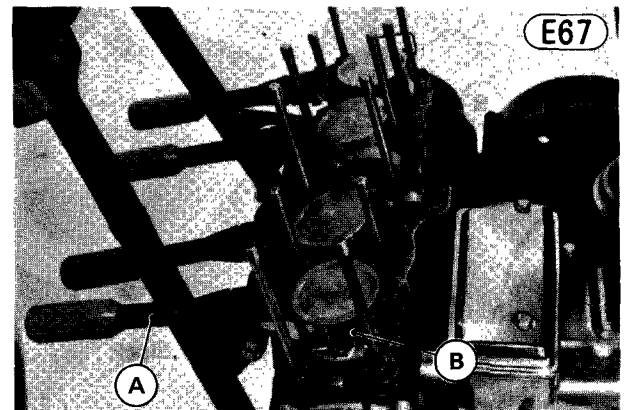

A. Piston Ring Compressor Grip (57001-1095)

B. Piston Ring Compressor Adapter (57001-1096)

- Check to see that the front chain guide is properly fitted in the cylinder block.
- Fit the cylinder block on the crankcase studs, inserting the rear chain guide into the cylinder block, and rest the bottom of the cylinders on the piston ring compressors.
- Pull the camshaft chain up through the cylinders and insert a screwdriver through it to prevent the chain from falling into the crankcase.
- Work the bottom of each cylinder past the rings, and set the cylinder block in place while removing the special tools. If the cylinder block does not seat on the crankcase, lift it up slightly, pull out the camshaft chain, and press the cylinder block down.

62 DISASSEMBLY—ENGINE INSTALLED

CAMSHAFT CHAIN GUIDES (Upper, Front, Rear)

Removal:

- Remove the cylinder block (Pg. 60).
- Remove the upper camshaft chain guide from the cylinder head cover.

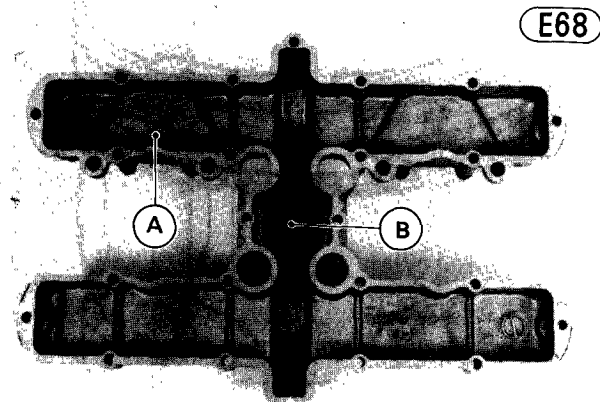

A. Cylinder Head Cover B. Upper Chain Guide

- Pushing the front camshaft chain guide up, remove the guide from the cylinder block.

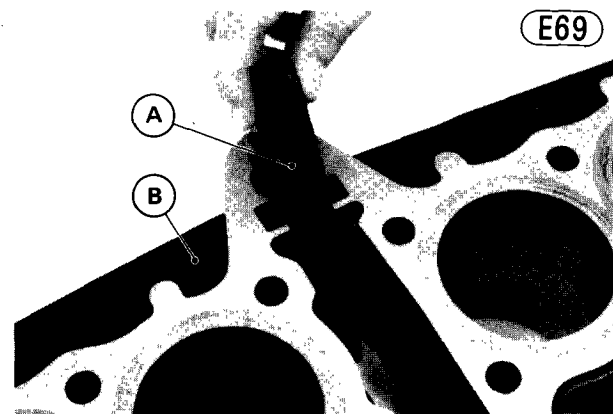

A. Front Chain Guide B. Cylinder Block

- Remove the rear camshaft chain guide from the crankcase.



- Remove the rubber dampers and pull off the guide shaft.

Installation Notes:

1. Install the rubber dampers on the guide shaft ends using an adhesive agent with the side marked "UP" facing upwards.

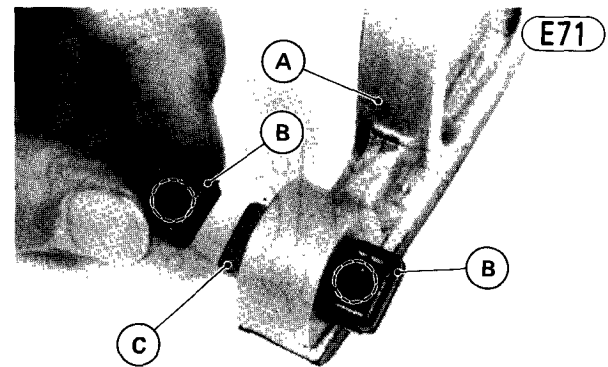

A. Rear Chain Guide C. Guide Shaft
B. Rubber Damper

2. Install the front chain guide in the cylinder block as shown.

Front Camshaft Chain Guide Installation

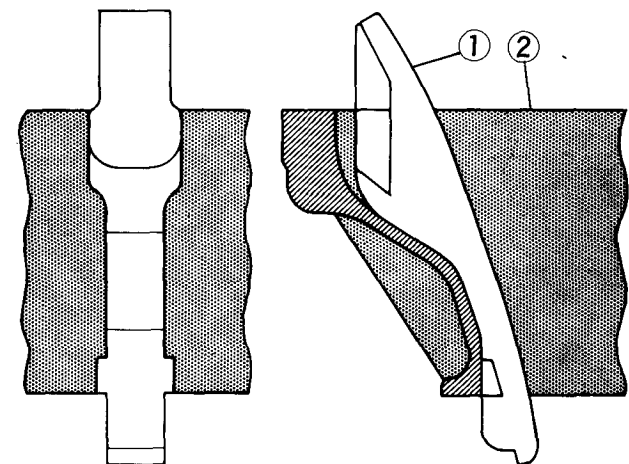

1. Front Camshaft Chain Guide
2. Cylinder Block

PISTONS, PISTON RINGS

Removal:

- Remove the cylinder block (Pg. 60).
- Wrap a clean cloth around the base of each piston so

- Remove the piston pin snap rings from the outside of each piston.

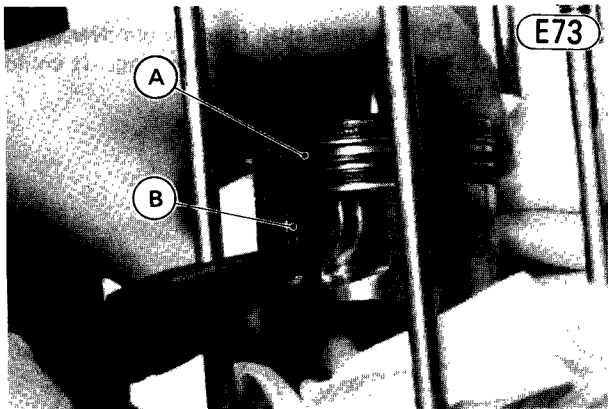

A. Piston B. Snap Ring

- Remove each piston by pushing its piston pin out the side that the snap ring was removed. Use the piston pin puller and adapter "B" (special tools) if necessary.

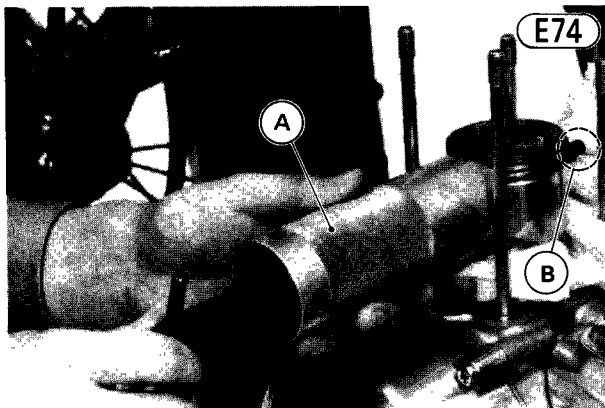

A. Piston Pin Puller (57001-910)
B. Adapter "B" (57001-913)

- Remove the top and second rings with the piston ring pliers (special tool). To remove a ring by hand, spread the ring opening with both thumbs, and then push up on the opposite side.

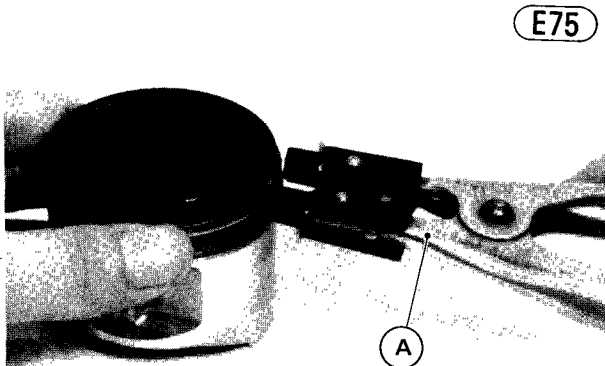

E75

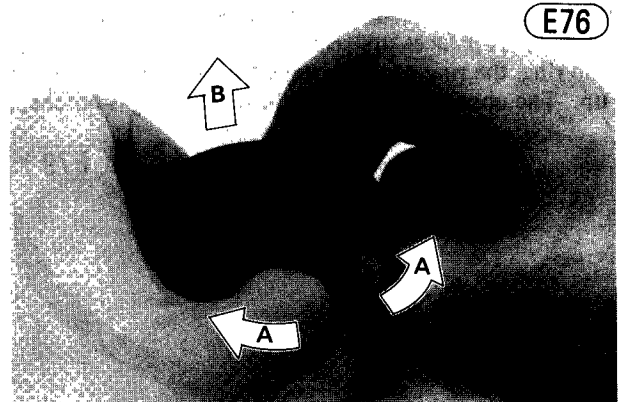

A. Spread. B. Push up.

- Remove the upper and lower oil ring steel rails, and then remove the oil ring expander.

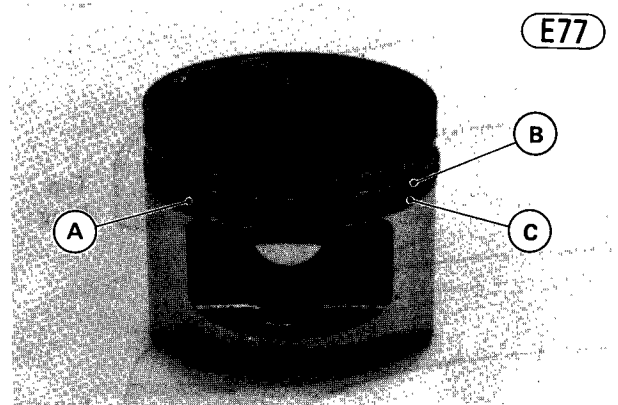

A. Oil Ring Expander B. Upper Steel Rail
C. Lower Steel Rail

Installation:

- To install the oil ring, first install the expander so that the expander ends butt together, and then install the upper and lower steel rails. The two steel rails are identical. There is no "up" or "down" to the rails; they can be installed either way.

Oil Ring Expander Installation

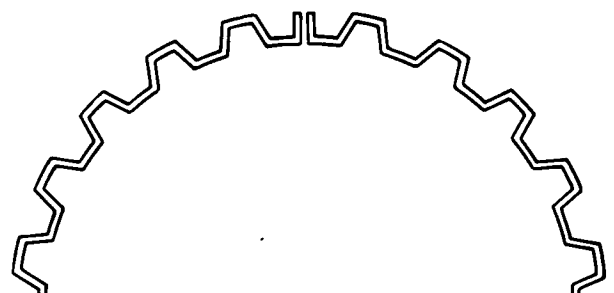

E78

64 DISASSEMBLY—ENGINE INSTALLED

- Install the top and second rings so that the correct side (marked "N") faces up. But, if there is no mark on the top ring, the ring can be installed with either side facing up. The upper inner edge of the second ring is notched.

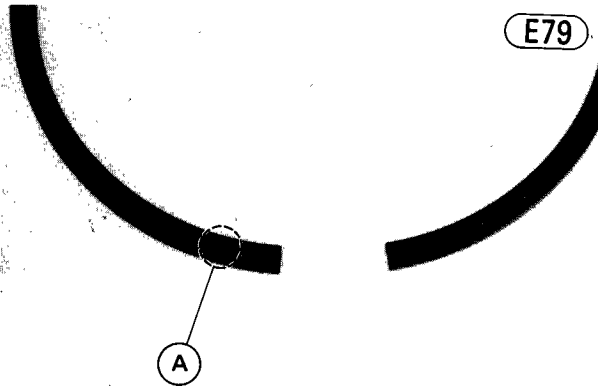

A. "N" Mark
Top Ring, Second Ring

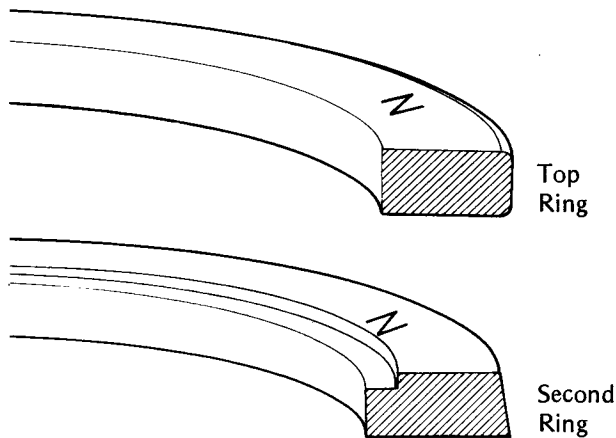

- Turn the rings so that the opening in the top ring and oil ring of each piston faces forward and the opening in the second ring faces the rear. The openings of the oil ring steel rails must be slipped to both directions about 30° from the opening of the expander (Fig. E66).
- Apply a little engine oil to the piston pins, and install the pistons and piston pins. The arrow on the top of each piston must point towards the front.

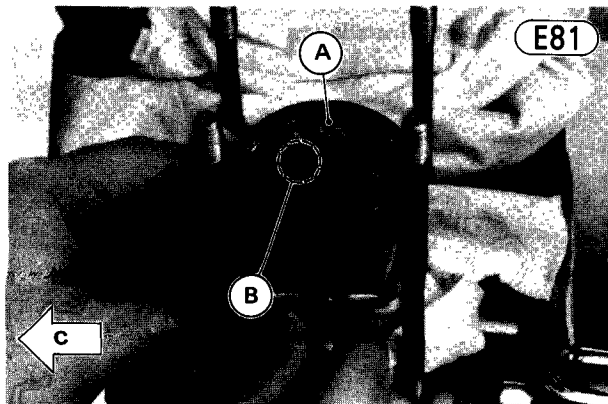

A. Piston B. Arrow Mark C. Front

- Fit a new piston pin snap ring into the side of each piston, taking care to compress it only enough to install it and no more. Check that the other snap ring is in place.

CAUTION Do not reuse snap rings, as removal weakens and deforms the snap ring. It could fall out and score the cylinder wall.

- Install the cylinder block (Pg. 60).

BREATHER COVER

Removal:

- Slide the clip out of place, and remove the breather hose from the breather cover.

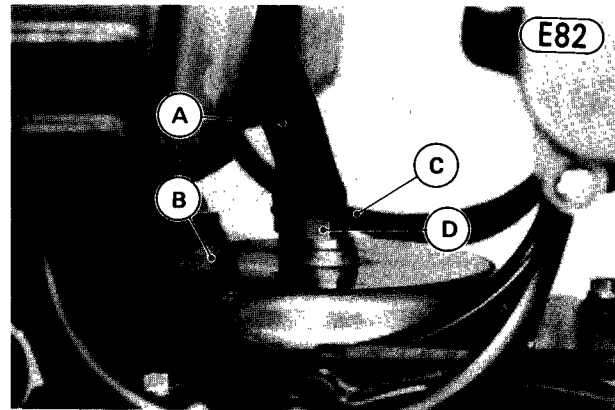

A. Breather Hose C. Clamp
B. Breather Cover D. Bolt

- Remove the breather cover bolt and cover.

Installation Notes:

1. Replace the breather cover O ring and cover bolt O ring with new ones if deteriorated or damaged.

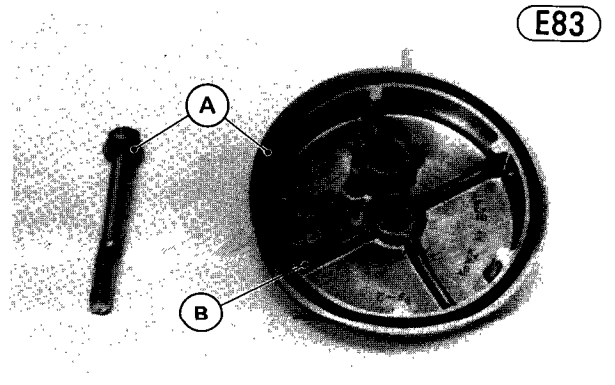

A. Breather Cover B. Bolt

DISASSEMBLY—ENGINE INSTALLED 65

- The projection of the breather cover must be installed between the positioning pin and mount on the crankcase.

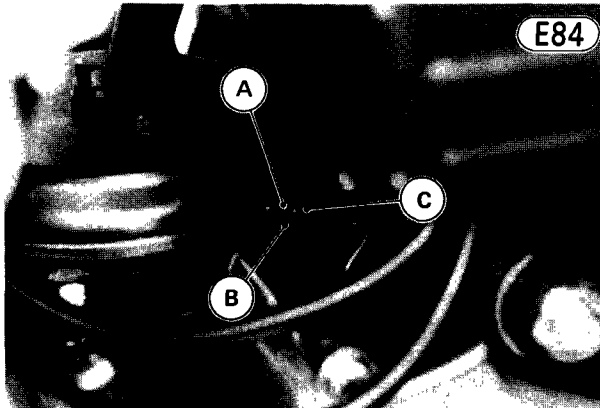

A. Breather Cover Projection **C. Pin**
B. Mount

- Tightening torque for the breather cover bolt is 0.60 kg-m (52 in-lbs).

Installation Notes:

- Check that the knock pins (2) are in place when installing engine sprocket cover.
- Check that the starter motor cover gasket is in place when installing the cover.
- Mount the shift pedal or shift pedal linkage so that the pedal end matches the level of the left footpeg.

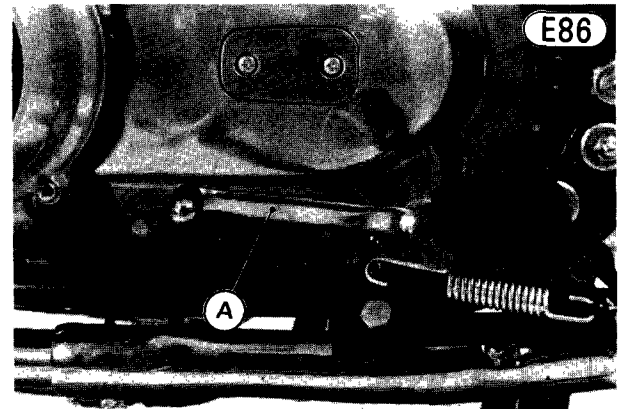

A. Shift Pedal

- Check that the shift pedal linkage (Pg. 20) and adjust it if necessary.

ENGINE SPROCKET COVER

Removal:

- Remove the left footpeg mounting nuts and left footpeg.

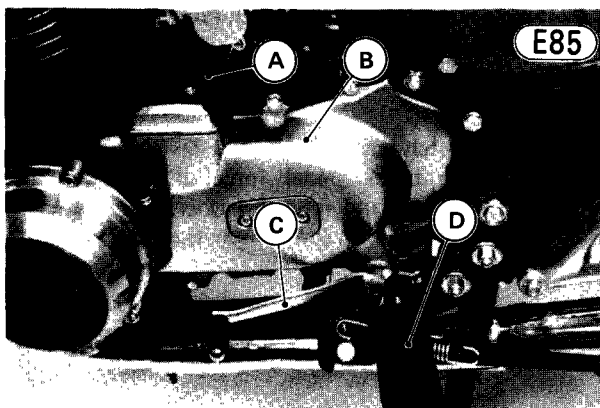

A. Starter Motor Cover **C. Shift Pedal**
B. Engine Sprocket Cover **D. Left Footpeg**

- Take out the shift pedal bolt, and remove the shift pedal.
- For the motorcycle which has the shift pedal linkage, remove the circlip at the shift pedal pivot and shift lever bolt, and take out the shift pedal linkage.
- Remove the starter motor cover bolts (2) and cover.
- Remove the engine sprocket cover bolts (4), and pull

CLUTCH RELEASE

Removal:

- Remove the engine sprocket cover.
- Remove the cotter pin from the clutch release lever, and free the clutch inner cable tip from the lever and engine sprocket cover.

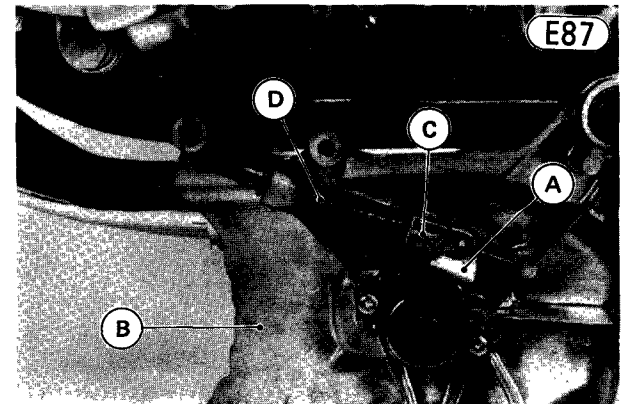

A. Clutch Release Lever **C. Cotter Pin**

66 DISASSEMBLY—ENGINE INSTALLED

- Remove the clutch release assembly mounting screws (2), and remove the release assembly.
- Take out the circlip, and separate the outer release gear and the inner release gear.

Clutch Release

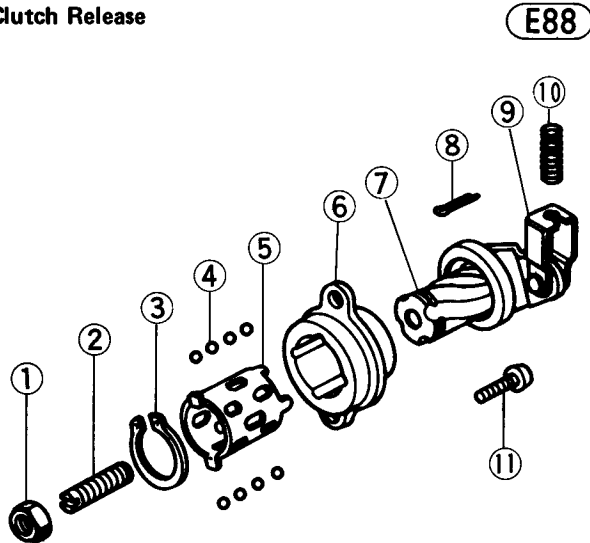

- | | |
|-----------------------|-----------------------|
| 1. Locknut | 7. Inner Release Gear |
| 2. Adjusting Screw | 8. Cotter Pin |
| 3. Circlip | 9. Release Lever |
| 4. Steel Ball | 10. Spring |
| 5. Ball Retainer | 11. Screw |
| 6. Outer Release Gear | |

Installation Notes:

1. Wash and clean the release balls (11) and inner release gear with a high flash-point solvent. Dry and then lubricate them with grease.
2. Fit the inner gear back into the outer release gear. When the two gears are fully meshed, the clutch release lever and the outer release gear must be positioned as shown in Fig. E89. The machined side of the outer release gear must face upward.

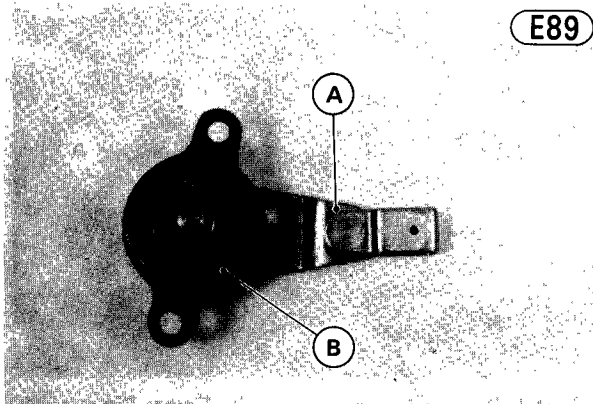

3. Fit the clutch release lever assembly back into the engine sprocket cover, apply a non-permanent locking agent to the screws, and tighten the screws. The clutch release lever must be positioned as shown in Fig. E87, when the gears are fully meshed.

ENGINE SPROCKET

Removal:

- Stand the motorcycle up on its center stand.
- Check that the transmission is in neutral.
- Remove the engine sprocket cover (Pg. 65).
- Straighten the side of the splined washer that is bent over the side of the engine sprocket nut.

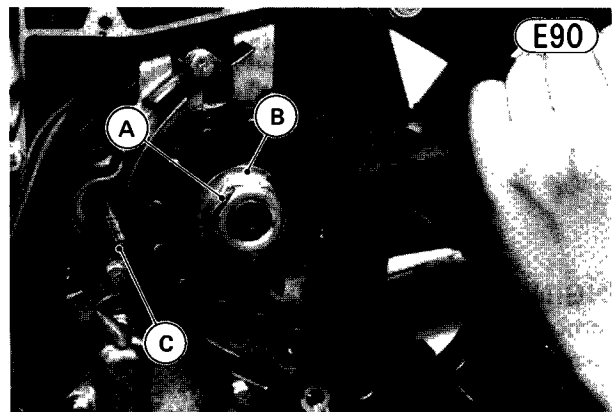

- A. Engine Sprocket Nut C. Clutch Push Rod
B. Washer

- Remove the clutch push rod.
- Depressing the brake pedal forcefully, remove the engine sprocket nut and splined washer.
- Remove the cotter pin, and loosen the rear axle nut.

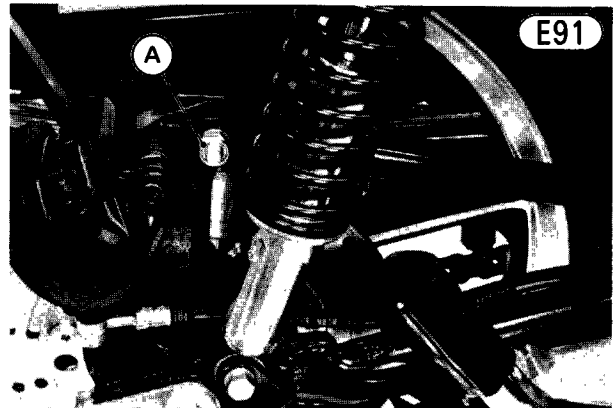

- Loosen the left and right chain adjusting bolt locknuts, and then back out the chain adjusting bolts. Kick the wheel forward to give the chain plenty of play.
- Loosen the nut at the rear end of the torque link.

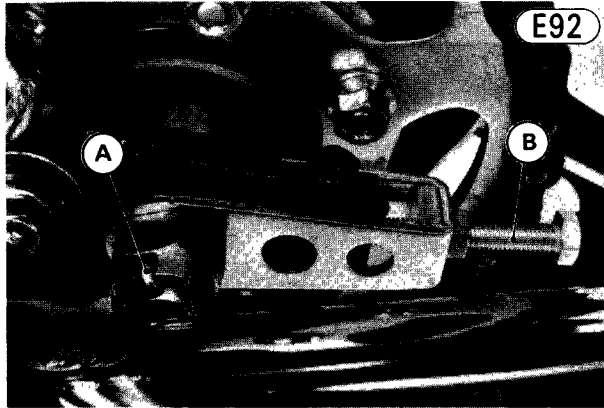

A. Torque Link Nut

- Remove the engine sprocket.

Installation:

- Mount the engine sprocket while meshed with the drive chain.
- Install the splined washer on the output shaft fitting their splines.
- Depressing the brake pedal forcefully, tighten the engine sprocket nut to 8.0 kg-m (58 ft-lbs) of torque.
- Bend one side of the splined washer over the side of the nut.
- Apply molybdenum disulfide engine assembly grease to the clutch push rod, and install the push rod.
- Install the engine sprocket cover (Pg. 65).
- Adjust the drive chain (Pg. 23).

EXTERNAL SHIFT MECHANISM

Removal:

- Remove the engine sprocket cover (Pg. 65).
- Remove the engine sprocket (Pg. 66).
- Disconnect the neutral switch lead.

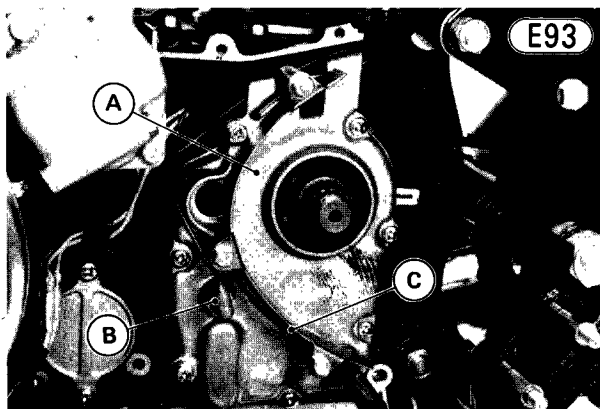

A. External Shift Mechanism Cover
B. Neutral Switch

- Remove the bolts (3) and the chain guard.
- Remove the external shift mechanism cover bolts (2) and screws (5), and pull off the external shift mechanism cover and gasket.

NOTE: Engine oil will drain through the bolt hole of the cover.

- Remove the output shaft collar.
- Move the shift arm and overshift limiter out of their positions on the end of the shift drum, and pull out the external shift mechanism.

NOTE: Do not pull the shift rod more than 40 mm out of the crankcase, or the shift forks inside the crankcase will fall to the bottom of the oil pan, requiring removal of the crankcase to install them.

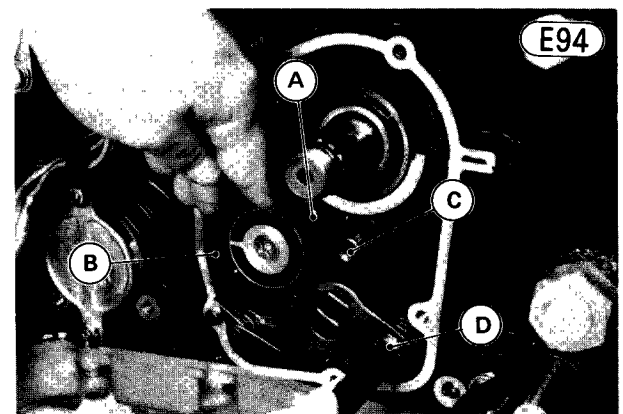

A. Overshift Limiter
B. Shift Arm

C. Shift Rod
D. Shift Mechanism

Installation:

- If the shift drum pins were removed, make sure the one long pin is assembled in the position shown. If this pin is assembled in the wrong position, the neutral indicator light will not light when the gears are in neutral.

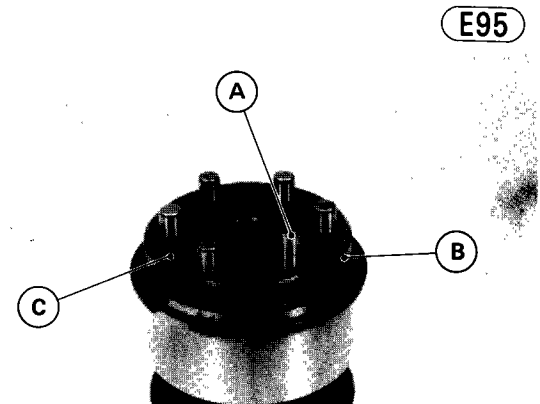

A. Long Pin

B. Shift Drum

C. Hole

- Check that the external shift mechanism return spring bolt is not loose. If it is loose, remove it, apply a non-permanent locking agent to the threads, and tighten it

68 DISASSEMBLY—ENGINE INSTALLED

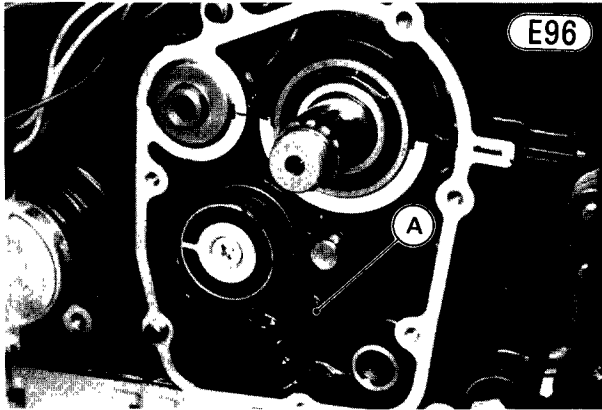

A. Return Spring Bolt

- Check that the return spring and pawl spring are properly fitted on the mechanism, install the external shift mechanism, and place the shift arm and overshift limiter on the shift drum pins.

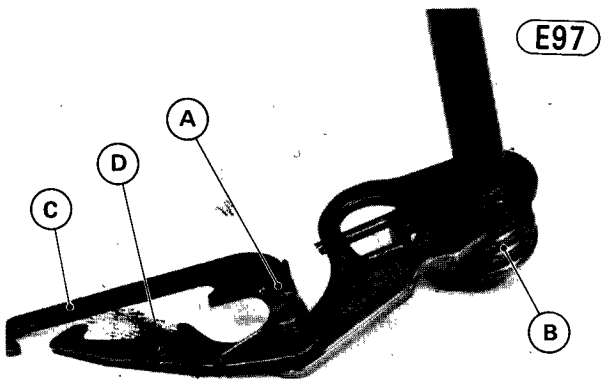

**A. Pawl Spring
B. Return Spring
C. Overshift Limiter
D. Shift Arm**

- Check that the two knock pins (2) and output shaft O ring are in place.

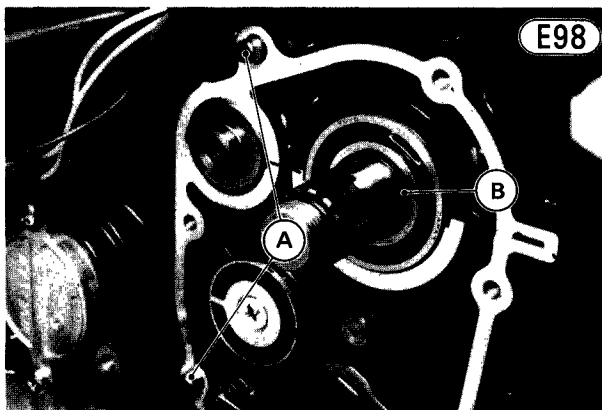

**A. Knock Pins
B. O Ring**

- Apply a high temperature grease to the lips of the clutch push rod oil seal and the output shaft collar oil

- Insert the shift shaft oil seal guide (special tool) in the external shift mechanism cover oil seal, install the cover and gasket, and then tighten the bolts (2) and screws (5). Each bolt must be installed with a new aluminum washer.

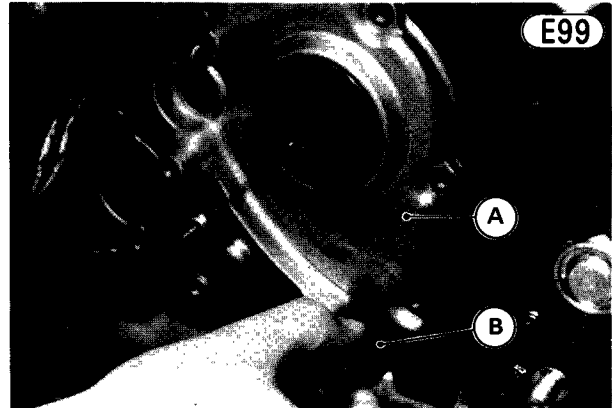

**A. External Shift Mechanism Cover
B. Shift Shaft Oil Seal Guide (57001-264)**

- Install the output shaft collar onto the output shaft. **NOTE:** The output shaft collar and drive shaft sleeve look the same, but the drive shaft sleeve has a small hole.

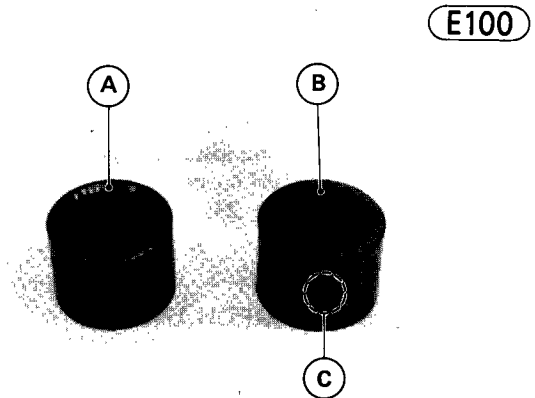

**A. Output Shaft Collar
B. Drive Shaft Sleeve
C. Small Hole**

- Apply a non-permanent locking agent to the bolts (3), and install the chain guard.
- Fit the neutral switch lead back on the switch.
- Install the engine sprocket (Pg. 67).
- Install the engine sprocket cover (Pg. 65).
- Adjust the drive chain (Pg. 23).

NEUTRAL SWITCH

Removal:

- Remove the engine sprocket cover (Pg. 65).

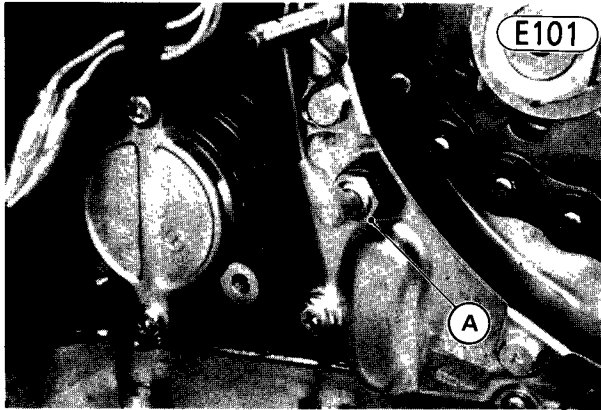

A. Neutral Switch

- Unscrew the neutral switch and gasket.

Installation Note:

- Install the neutral switch and gasket tightening it to 1.5 kg-m (11.0 ft-lbs) of torque.

Starter Motor

STARTER MOTOR

Removal:

- Remove the engine sprocket cover (Pg. 65).
- Remove the starter motor retaining bolts (2).

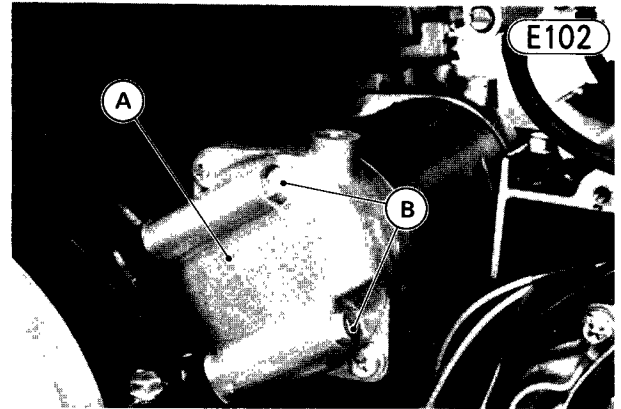

A. Starter Motor

B. Retaining Bolts

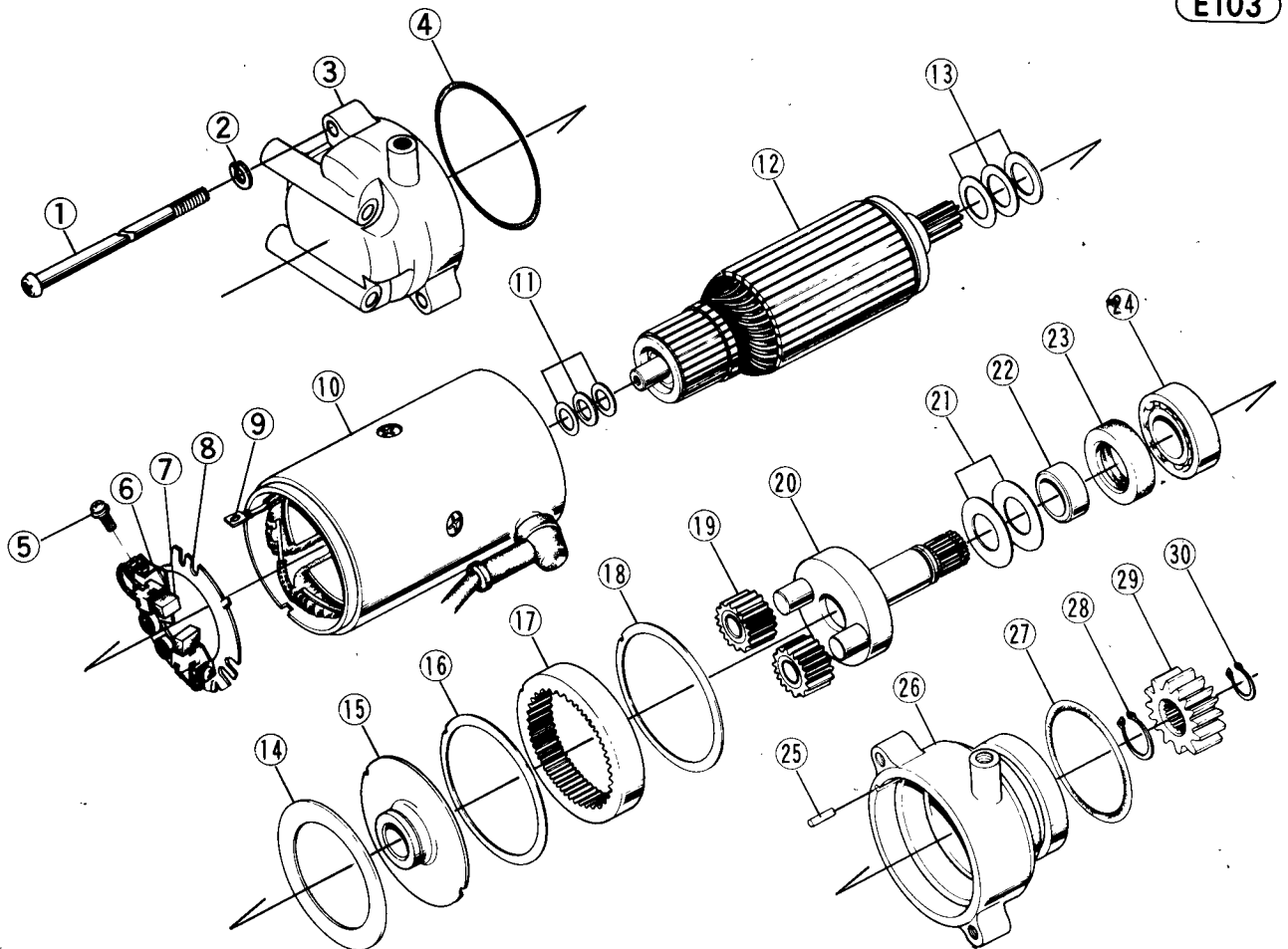

- | | | | | |
|---------------|--------------------|--------------------|--------------------|---------------|
| 1. Screw | 7. Carbon Brush | 13. Thrust Washers | 19. Planet Pinion | 25. Pin |
| 2. Lockwasher | 8. Brush Plate | 14. Gasket | 20. Output Shaft | 26. End Cover |
| 3. End Cover | 9. Field Coil Lead | 15. End Plate | 21. Thrust Washers | 27. O Ring |
| 4. O Ring | 10. Yoke Assembly | 16. Gasket | 22. Bushing | 28. Circlip |
| 5. Screw | 11. Thrust Washers | 17. Internal Gear | 23. Grease Seal | 29. Pinion |

70 DISASSEMBLY—ENGINE INSTALLED

- Pull off the starter motor.
- Remove the starter motor terminal nut and lockwasher, and take the lead off the starter motor.

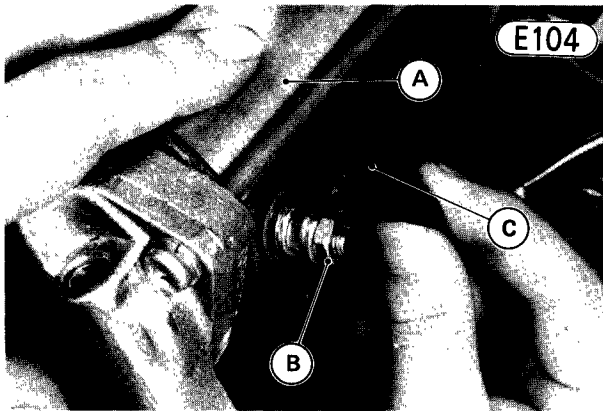

A. Starter Motor **C. Lead**
B. Terminal Nut

Installation:

- Replace the O ring with a new one, if it is deteriorated or damaged, any apply a little oil to it.
- Reconnect the motor lead onto the terminal with its nut and lockwasher, tighten the nut, and recap the terminal cap.
- Clean the starter motor lugs and crankcase where the starter motor is grounded.

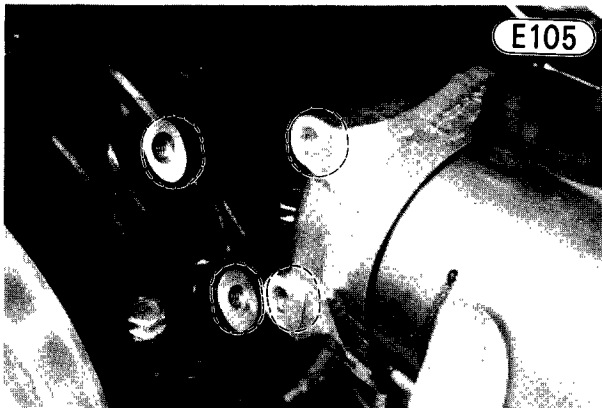

- Place the starter motor back into position fitting the shaft through the idle gear.
- Tighten the starter motor retaining bolts (2).
- Install the engine sprocket cover (Pg. 65).
- Install the left side cover.

Disassembly:

- Remove the screws ① (2), lockwashers ② (2), and remove the end covers ③, ②⑥.
- Remove the gasket ⑫, end plate ⑮, gasket ⑭, thrust washers ⑬ and armature ⑫ from the shaft side.
- Remove the screw which connects the brush lead ⑥ to the filed coil lead ⑨, and remove the brush plate ⑧. The screw has a lockwasher. There is an O ring ④ at the brush side of the housing.

NOTE: The yoke assembly ⑩ is not meant to be disassembled.

- Remove the planet pinions ⑲, internal gear ⑰, and

Assembly Notes:

1. Replace any O rings and gaskets that are deteriorated or damaged with new ones.
2. Align the torque on the brush plate with the notch on the end cover, and align the line on each end cover with its lines on the housing.

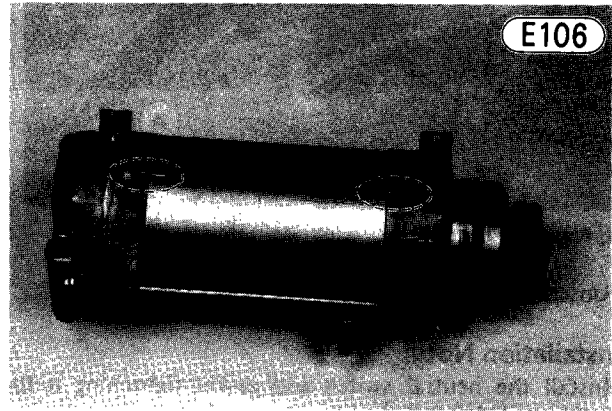

3. Apply a high temperature grease to the planet pinions ⑲ and internal gear ⑰.
4. Install the starter motor pinion so that the chamfered surface faces out.

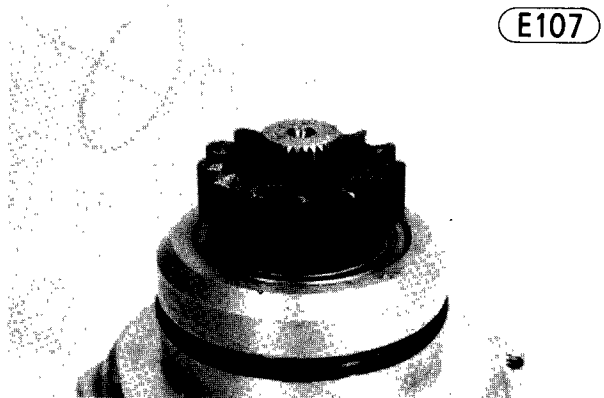

ALTERNATOR STATOR

Removal:

- Remove the engine sprocket cover (Pg. 65).
- Disconnect the alternator wiring yellow leads.

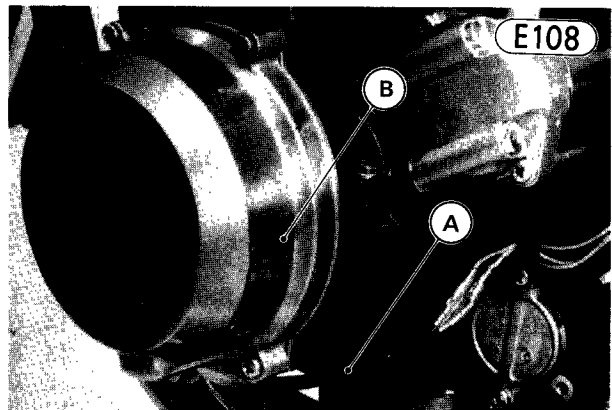

Alternator

E109

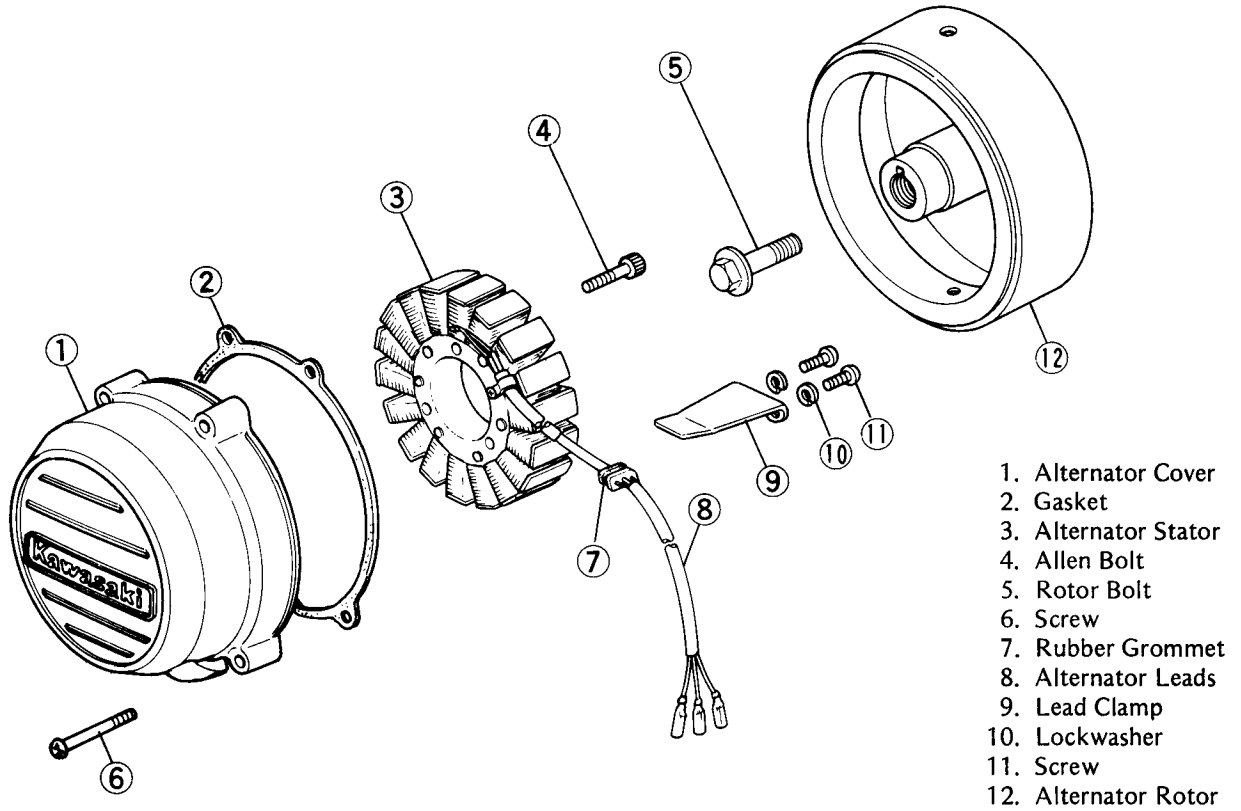

- 1. Alternator Cover
- 2. Gasket
- 3. Alternator Stator
- 4. Allen Bolt
- 5. Rotor Bolt
- 6. Screw
- 7. Rubber Grommet
- 8. Alternator Leads
- 9. Lead Clamp
- 10. Lockwasher
- 11. Screw
- 12. Alternator Rotor

- Remove the alternator cover screws (4), and pull off the alternator cover and gasket.
- Remove the wiring clamp screws (2) and wiring clamp.

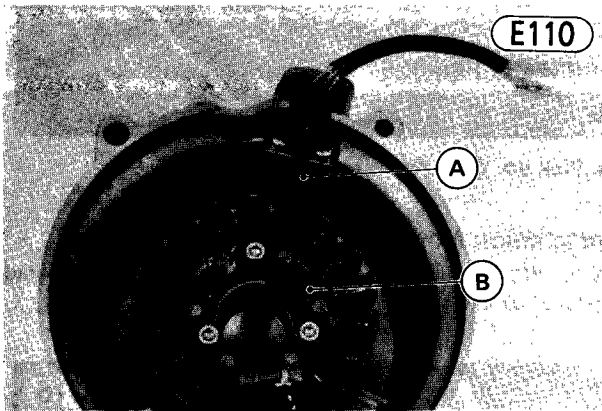

E110

A. Wiring Clamp B. Alternator Stator

- Remove the alternator stator Allen bolts (3), and pull out the alternator stator.

Installation Notes:

1. Install the grommet, and fit the stator into place. Use a non-permanent locking agent on each Allen bolt, and tighten the bolts to 0.8 kg-m (69 in-lbs) of torque.
2. Check that the knock pins (2) are in place, install the alternator cover and a new gasket, and tighten

ALTERNATOR ROTOR

Removal:

- Remove the engine sprocket cover (Pg. 65).
- Disconnect the alternator wiring yellow leads (Fig. E108).
- Remove the alternator cover screws (4), and pull off the alternator cover and gasket.
- Hold the alternator rotor steady with the rotor holder (special tool), and remove the rotor bolt.

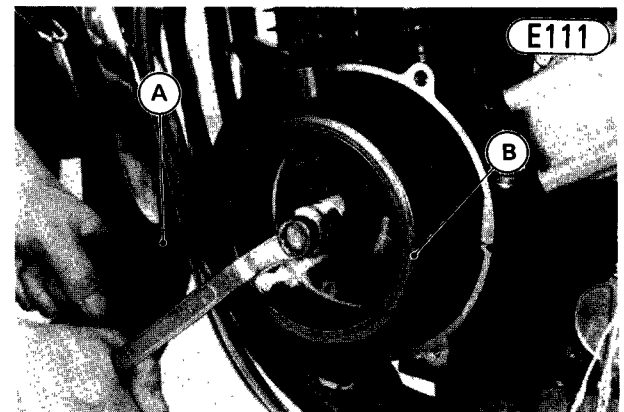

E111

A. Rotor Holder (57001-308) B. Rotor

- Using the special tool to hold the rotor steady, remove the rotor with the rotor puller (special tool).

CAUTION If the rotor is difficult to remove and a hammer is used, turn the box with hand

72 DISASSEMBLY—ENGINE INSTALLED

Do not attempt to strike the bar or the alternator rotor itself. Striking the bar or the rotor can cause the bending or the magnets to lose their magnetism.

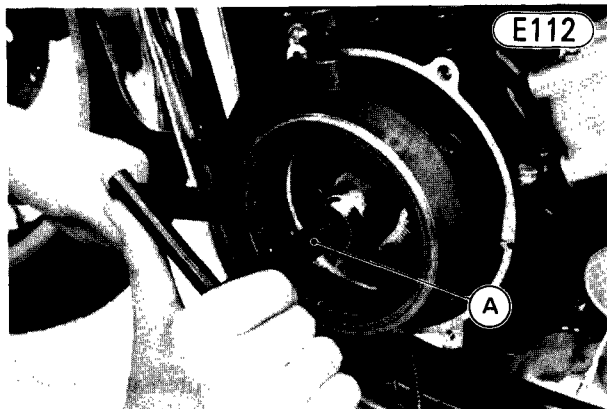

A. Rotor Puller (57001-254 or 57001-1099)

Installation Notes:

1. Using a high flash-point solvent, clean off any oil or dirt that may be on the crankshaft taper or rotor hub, and place the rotor back on the crankshaft.
2. Tighten the rotor bolt to 7.0 kg-m (51.0 ft-lbs) of torque while holding the alternator rotor steady with the rotor holder (special tool).
3. Check that the knock pins (2) are in place, install the alternator cover using a new gasket, and tighten its screws (4).

PICK-UP COIL ASSEMBLY

Removal:

- Remove the pick-up coil cover and gasket.

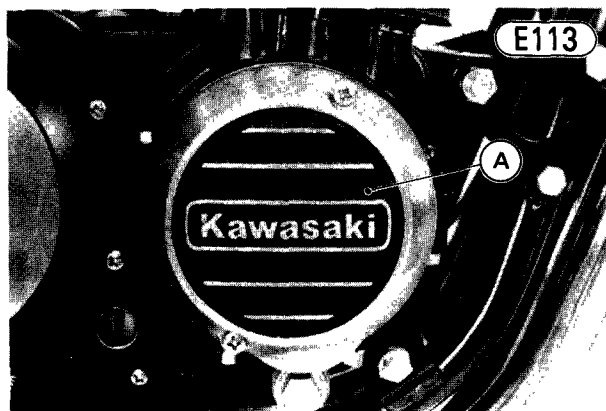

A. Pick-up Coil Cover

- Disconnect the 4-pin connector that joins the pick-up coil leads to the IC igniter, and slide the leads free from the clamps.

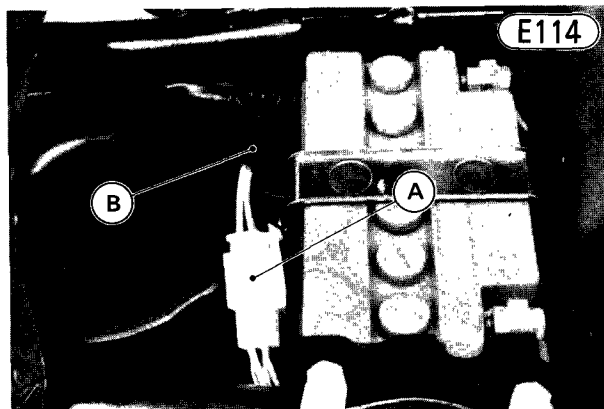

A. 4-Pin Connector B. Pick-up Coil Leads

- Remove the mounting screws, disconnect the oil pressure switch lead, and take off the pick-up coil assembly.

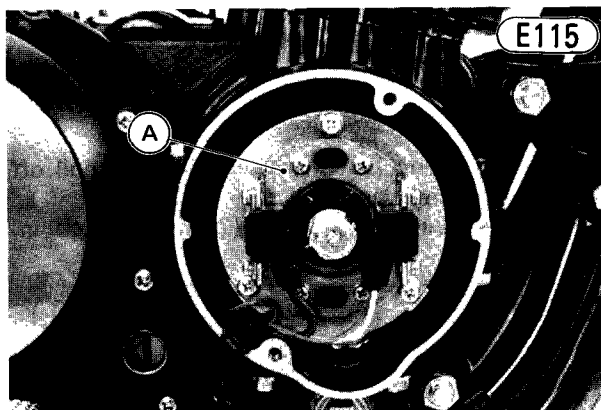

A. Pick-up Coil Assembly

Installation Note:

- Connect the oil pressure switch lead so that the lead points to the rear.

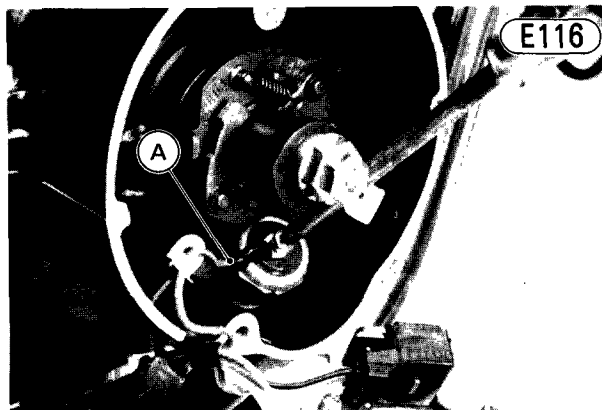

TIMING ADVANCER

Removal:

- Remove the pick-up coil assembly (Pg. 72).
- With a 17 mm wrench on the crankshaft rotation nut to keep the shaft from turning, remove the advancer mounting bolt, and take off the rotation nut and the timing advancer.

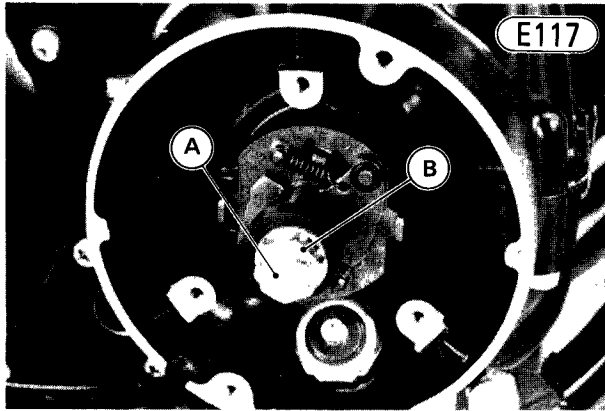

**A. Timing Advancer Mounting Bolt
B. Crankshaft Rotation Nut**

Installation:

- Fit the timing advancer onto the crankshaft, matching its notch with the pin in the end of the crankshaft, and install the crankshaft rotation nut and advancer mounting bolt. The notches in the nut fit the projections on the timing advancer. Tighten the bolt to 2.5 kg-m (18.0 ft-lbs) of torque.

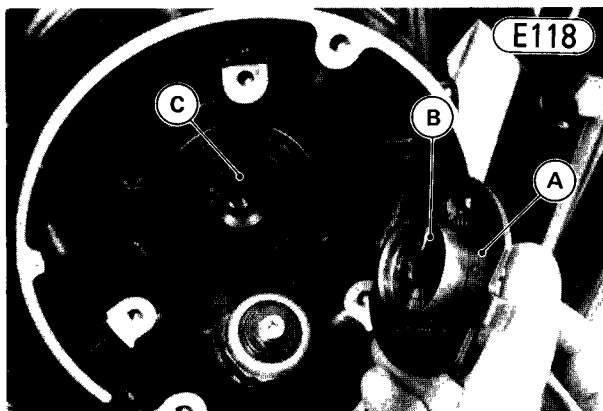

A. Timing Advancer B. Notch C. Pin

- Install the pick-up coil assembly.

Disassembly:

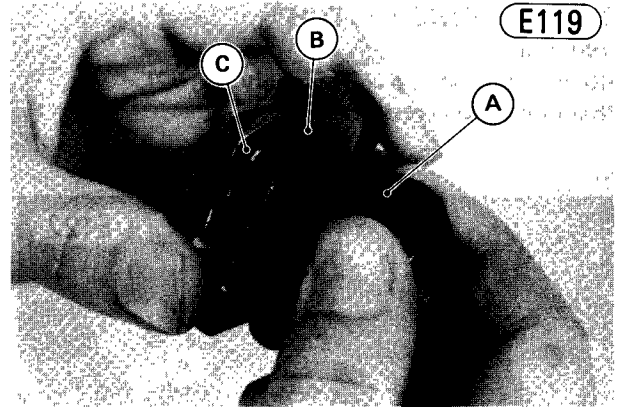

A. Timing Rotor B. Weight C. "C" Ring

- Remove the C rings (2), washers (4), and weights (2).
- Remove the thrust washer from each weight shaft.

Assembly Notes:

1. Wipe the advancer clean, and fill the groove in the timing rotor with grease.

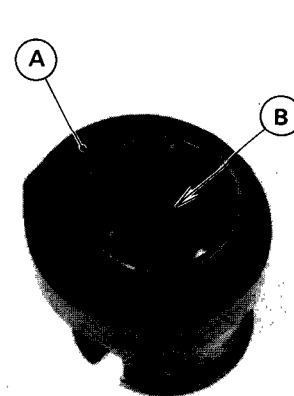

A. Timing Rotor B. Grease

2. When installing the timing rotor, align the projection on the rotor with the "TEC" mark on the advancer body.

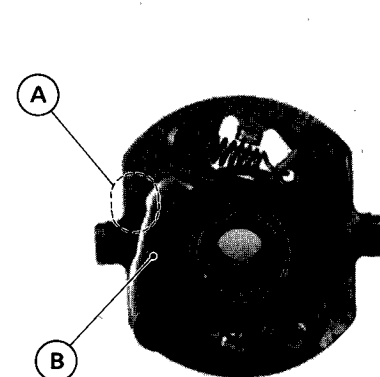

74 DISASSEMBLY—ENGINE INSTALLED

OIL PRESSURE SWITCH

Removal:

- Remove the pick-up coil assembly (Pg. 72).
- Remove the oil pressure switch.

Installation Note:

- Tighten the oil pressure switch to 1.5 kg-m (11.0 ft-lbs) of torque.

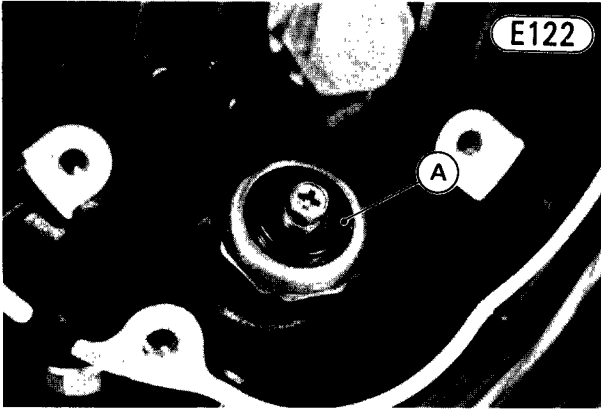

A. Oil Pressure Switch

CLUTCH

Removal:

- With the motorcycle on its center stand, place an oil pan beneath the engine, and remove the engine drain plug and washer to drain out the oil.
- After the oil has drained, tighten the drain plug to 3.8 kg-m (27 ft-lbs) of torque.
- Remove the mounting nuts and right footpeg.
- Remove the screws (10), and pull off the clutch cover and gasket. There are two knock pins.

Clutch

E123

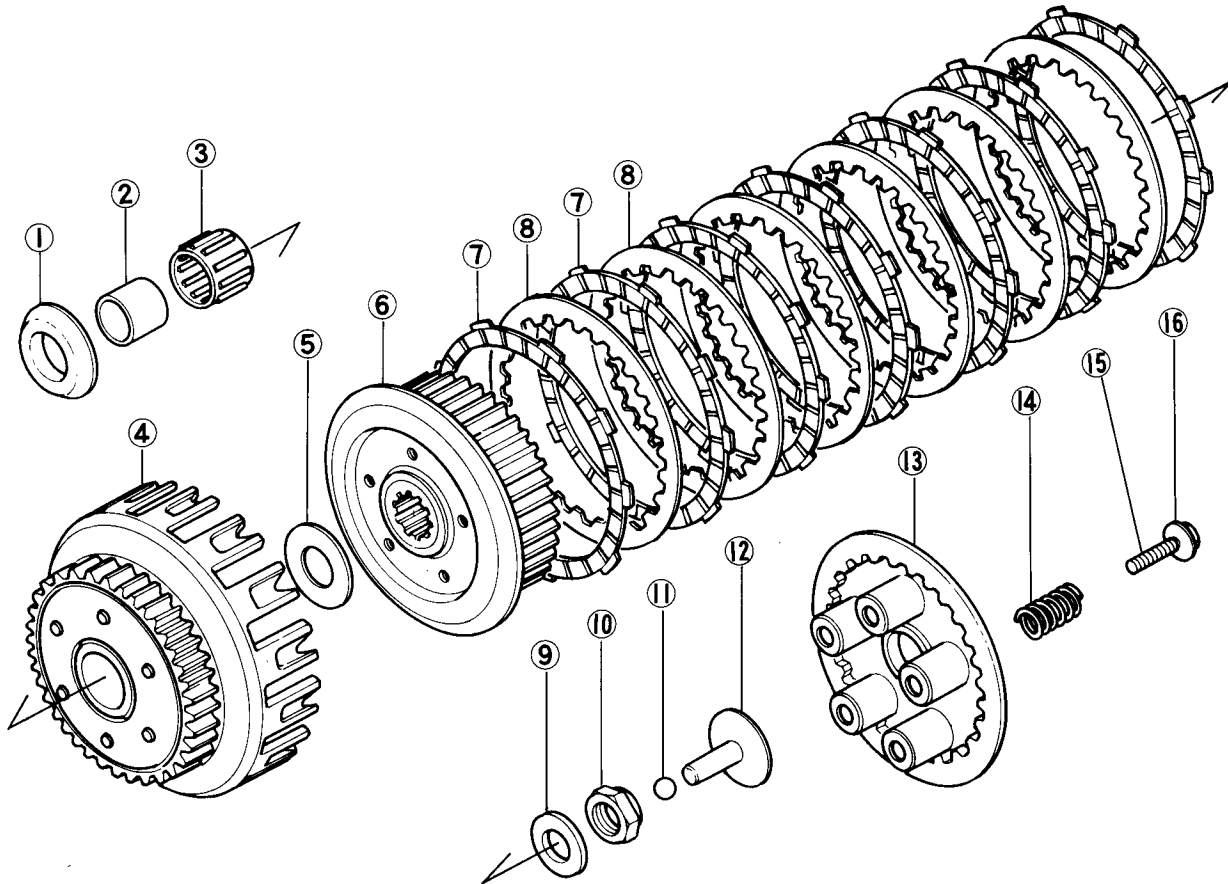

1. Spacer
2. Sleeve
3. Needle Bearing
4. Clutch Housing

5. Thrust Washer
6. Clutch Hub
7. Friction Plate
8. Steel Plate

9. Lockwasher
10. Locknut
11. Steel Ball
12. Pin

13. Spring Plate
14. Clutch Spring
15. Bolt
16. Washer

DISASSEMBLY—ENGINE INSTALLED 7!

- Remove the clutch spring bolts ⑮ (5), washers ⑯ (5), and springs ⑭ (5).

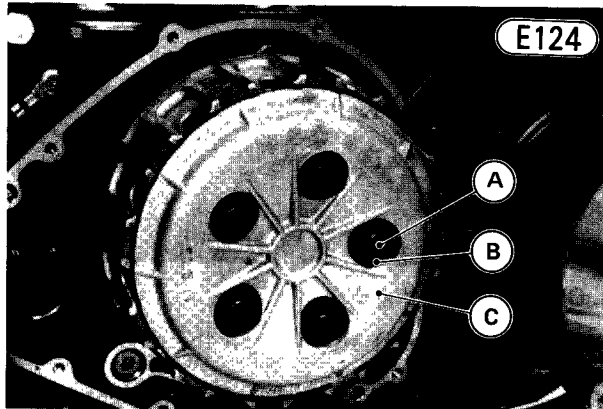

A. Clutch Spring Bolt **C. Spring Plate**
B. Washer

- Pull off the spring plate ⑬, pull out the spring plate pusher ⑫, and tilt the motorcycle so that the steel ball ⑪ will fall out.
- Remove the friction plates ⑦ (7) and steel plates ⑧ (6).
- Hold the clutch hub from turning using the clutch holder (special tool), and remove the clutch hub locknut ⑨ and lockwasher ⑩.

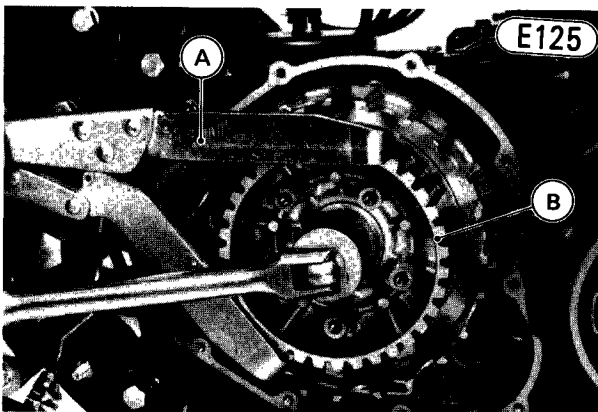

A. Clutch Holder (57001-305) **B. Clutch Hub**

- Pull off the clutch hub, clutch housing, needle bearing, drive shaft sleeve, and spacer. There is a thrust washer between the clutch hub and clutch housing.

Installation:

- Put the clutch housing spacer on the drive shaft. The spacer must be installed with its flat side facing toward

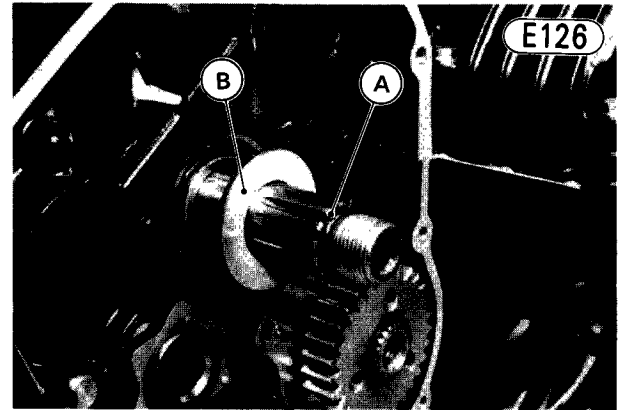

A. Drive Shaft **B. Clutch Housing Spacer**

- Install the drive shaft sleeve, needle bearing, and clutch housing.

NOTE: The drive shaft sleeve and output shaft collar look the same, but the drive shaft sleeve has a small hole (Fig. E100).

- Put on the thrust washer, clutch hub, and lockwasher. Replace the clutch hub locknut with a new one, screw on the locknut and tighten it to 13.5 kg-m (98 ft-lbs) of torque, while holding the hub stationary with the clutch holder (special tool).

WARNING The lockwasher between the clutch hub and the clutch hub locknut must be installed with the marked side, "OUTSIDE", facing out. If this washer is installed backwards, the hub locknut might loosen during operation. This causes clutch disengagement resulting in loss of motorcycle control.

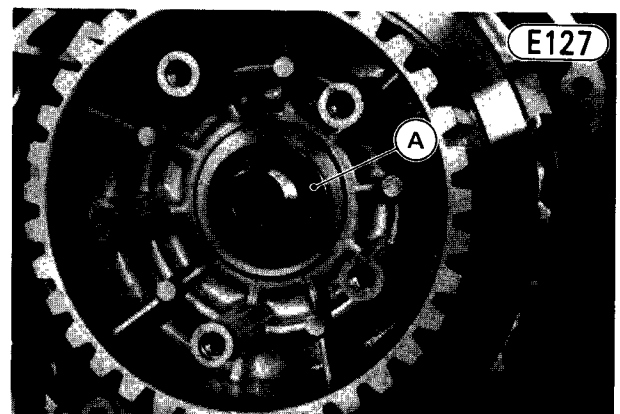

A. Lockwasher

- Install the friction plates (7) and steel plates (6), starting with a friction plate and alternating them.

CAUTION If new dry steel plates and friction plates are installed, apply engine oil on the surfaces of each plate to avoid clutch plate seizure.

- Insert the clutch steel ball, and spring plate pusher, applying a thin coat of a molybdenum disulfide engine

76 DISASSEMBLY—ENGINE INSTALLED

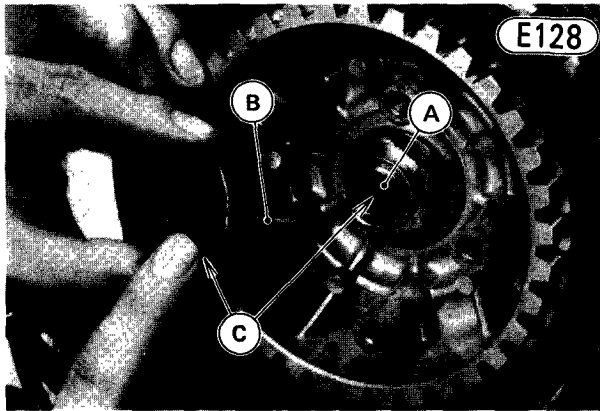

A. Steel Ball **C. Grease.**
B. Spring Plate Pusher

- Install the spring plate, springs, washers, and spring bolts (5 ea). Cross tighten the bolts evenly to 0.90 kg-m (78 in-lbs) of torque.

NOTE: The spring plate can be installed on the clutch hub in any position, so there is no mark on either the spring plate or the clutch hub.

- Apply a liquid gasket to the crankcase halves matching surface on the front and rear sides of the clutch.
- Check that the knock pins (2) are in place, fit a new clutch cover gasket, and install the clutch cover. Tighten the screws (9) firmly. Be sure to include the pick-up coil leads clamps (2) with the clutch cover screws.

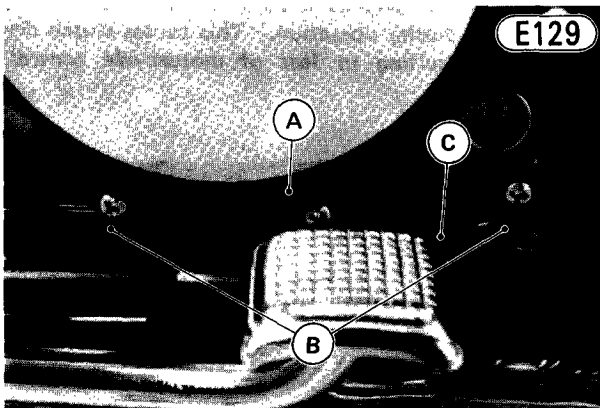

A. Clutch Cover **B. Clamps** **C. Pick-up Coil Leads**

- Install the right footpeg.
- Fill the engine with oil, check the oil level (Pg. 19), and add more if necessary.
- Adjust the clutch (Pg. 17).

OIL FILTER, BYPASS VALVE

Removal:

- With the motorcycle up on its center stand, place an oil pan beneath the engine and remove the oil filter

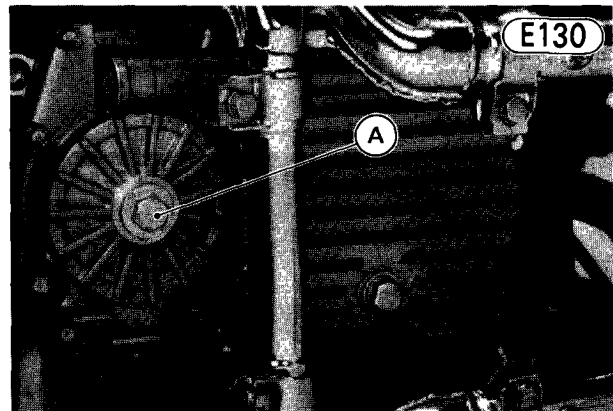

A. Oil Filter Mounting Bolt

- Holding the element steady, turn the mounting bolt to work the element free.
- Remove the flat washer, spring, and element fence, and pull the filter cover off the bolt.

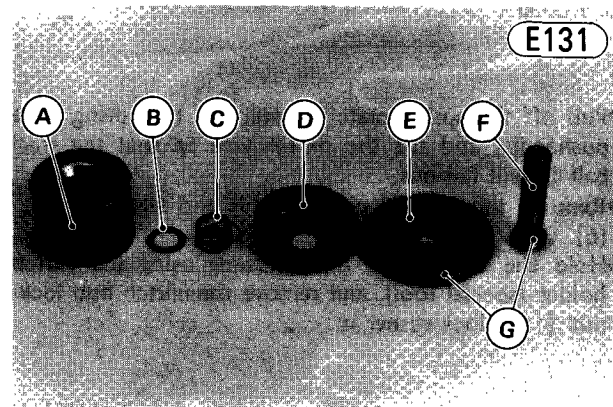

A. Element **E. Filter Cover**
B. Flat Washer **F. Mounting Bolt**
C. Spring **G. "O" Rings**
D. Element Fence

- To remove the bypass valve steel ball, drive the pin and drop out the spring and steel ball from mounting bolt.

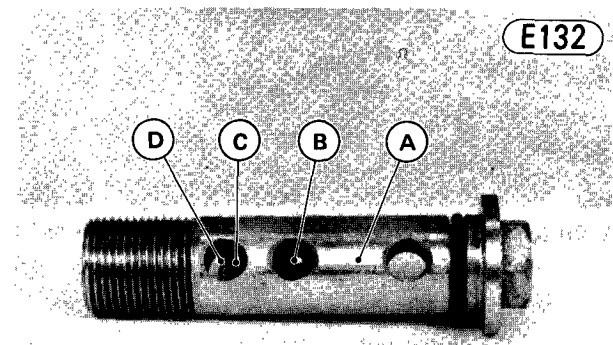

A. Mounting Bolt **C. Spring**
B. Steel Ball **D. Pin**

Installation:

CAUTION Using damaged or deteriorated O rings

DISASSEMBLY—ENGINE INSTALLED 77

oil left in the engine. This will cause serious engine damage. The oil in the oil filter housing is pressurized by the engine oil pump, so these O rings must be inspected with special care. Look for discoloration (indicating the rubber has deteriorated), hardening (the sides which face the mating surfaces are flattened), scoring, or other damage.

- Fit the steel ball and spring into the mounting bolt, and drive in the pin while pressing the spring.
- Apply a little engine oil to the O ring on the filter mounting bolt, fit the filter cover and element fence on the bolt, and install the spring and flat washer.
- Apply a little engine oil to the oil filter grommets on the both sides of the element, and holding the filter steady, turn the filter mounting bolt to work the element into place. Be careful that the element grommets do not slip out of place.

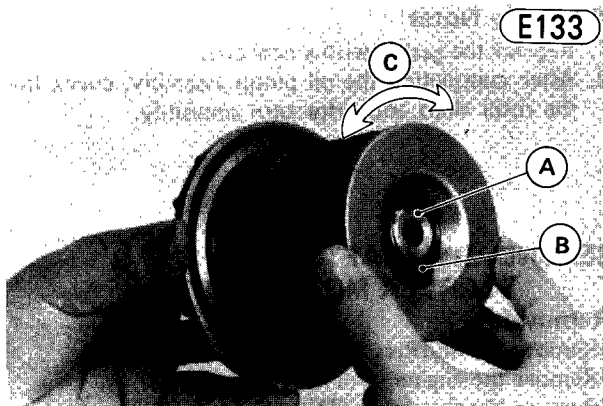

A. Mounting Bolt B. Grommet C. Turn.

- Install the oil filter, and tighten its mounting bolt to 2.0 kg-m (14.5 ft-lbs) of torque.
- Check the oil level (Pg. 19), and add more if necessary.

OIL PAN, OIL PRESSURE RELIEF VALVE Removal:

●With the motorcycle on its center stand, place an oil pan beneath the engine, and remove the engine oil drain plug and oil filter mounting bolt to drain out the oil.

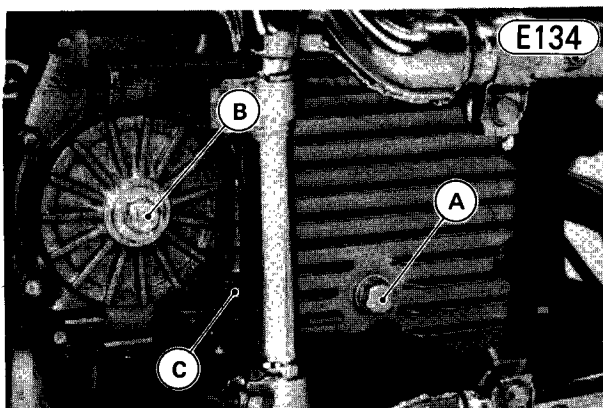

A. Engine Drain Plug C. Oil Pan

- After the oil has drained out, install the drain plug and tighten it to 3.8 kg-m (27 ft-lbs) of torque.
- Remove the mufflers (Pg. 50).
- Remove the oil pan bolts (15), and remove the oil pan, gasket, and oil passage O rings (3).
- Unscrew the oil pressure relief valve from the oil pan.

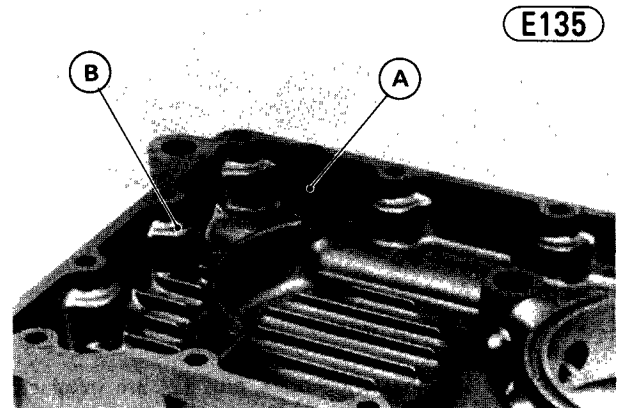

A. Oil Pressure Relief Valve B. Oil Pan

Installation Notes:

1. Use a non-permanent locking agent on the valve thread, and tighten the valve to 1.5 kg-m (11.0 ft-lbs) of torque.
2. Replace the oil passage O rings (3) and oil pan gasket with new ones. The flat side of the O ring must face to the crankcase.

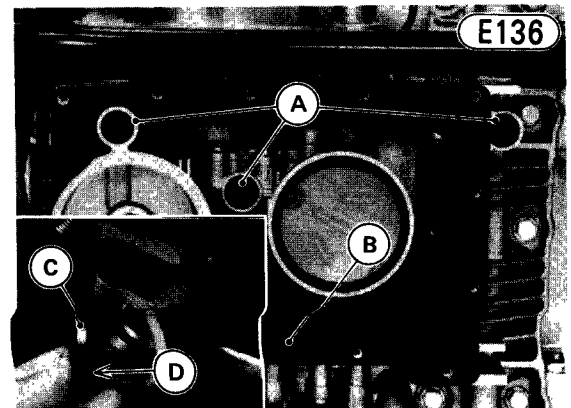

A. Oil Passage "O" Rings C. "O" Ring
B. Oil Pan Gasket D. Flat Side

3. Tighten the oil pan bolts (15) to 1.0 kg-m (87 in-lbs) of torque, and the engine drain plug to 3.8 kg-m (27 ft-lbs) of torque.

ENGINE OIL PUMP

Removal:

- Remove the oil pan.
- Remove the clutch (Pg. 74).
- Remove the mounting bolt and screws (2), and pull off the oil pump. There are two knock pins on the

78 DISASSEMBLY—ENGINE INSTALLED

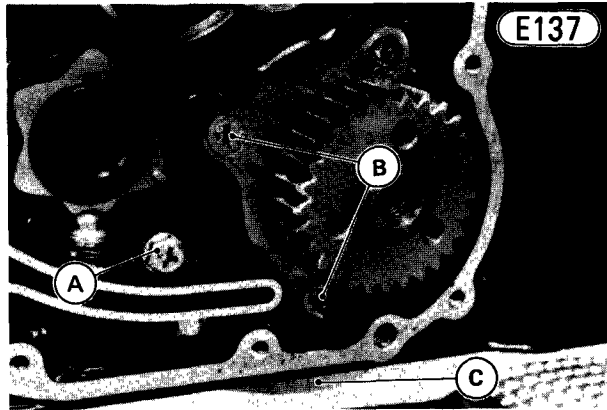

A. Mounting Bolt
B. Mounting Screws
C. Oil Pump

Installation Notes:

1. Fill the oil pump with engine oil for initial lubrication.
2. Check to see that the knock pins (2) are in place.

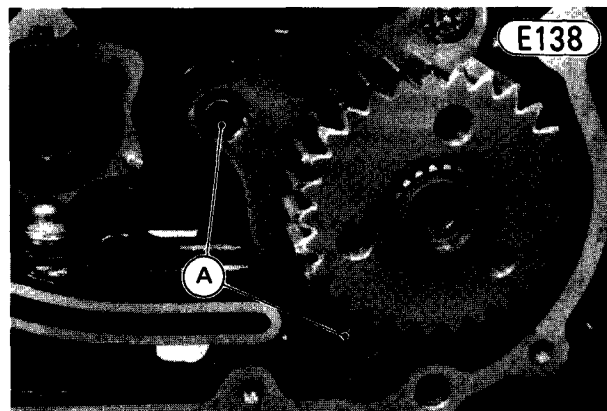

A. Knock Pins

Oil Pump

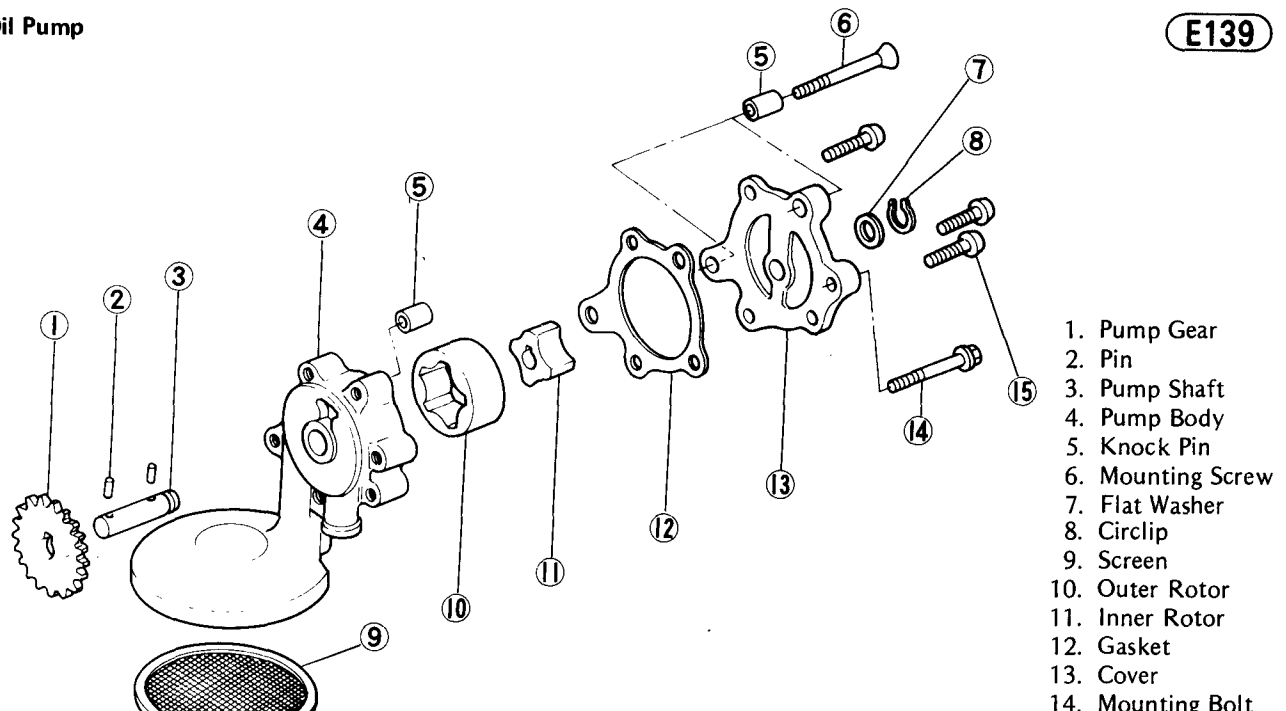

1. Pump Gear
2. Pin
3. Pump Shaft
4. Pump Body
5. Knock Pin
6. Mounting Screw
7. Flat Washer
8. Circlip
9. Screen
10. Outer Rotor
11. Inner Rotor
12. Gasket
13. Cover
14. Mounting Bolt

3. Be sure the oil pump gear and pump drive gear at the secondary shaft mesh properly.
4. Stake each oil pump screw head with a punch to prevent loosening.

Disassembly:

- Remove the circlip (8) and washer (7) on the pump shaft end.
- Remove the oil pump cover screws (15) (3), and take off the oil pump cover (13) and gasket (12).
- Take out the rotors (10, 11).
- Take out the pin (2), and pull off the oil pump gear (1) and shaft (3).
- Slide off the pump gear, and take out the pin (2) from the shaft.

Assembly Notes:

1. Replace the gasket with a new one.
2. After completing the oil pump assembly, check that the rotor shaft and rotor turn smoothly.

SECONDARY SHAFT, STARTER MOTOR CLUTCH

Removal:

- Remove the mufflers (Pg. 50).
- Remove the engine sprocket cover (Pg. 65).
- Remove the clutch (Pg. 74).
- Remove the oil pump (Pg. 77).
- Remove the alternator cover.
- Remove the screws (2), and pull off the secondary shaft bearing cap.

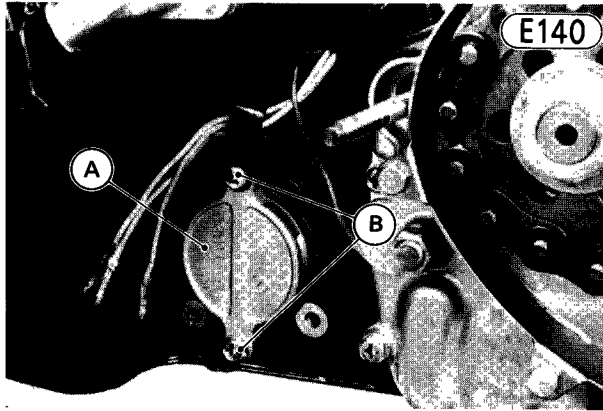

A. Secondary Shaft Bearing Cap **B. Screws**

- Using the rotor holder (special tool) to hold the alternator rotor, remove the secondary shaft nut.

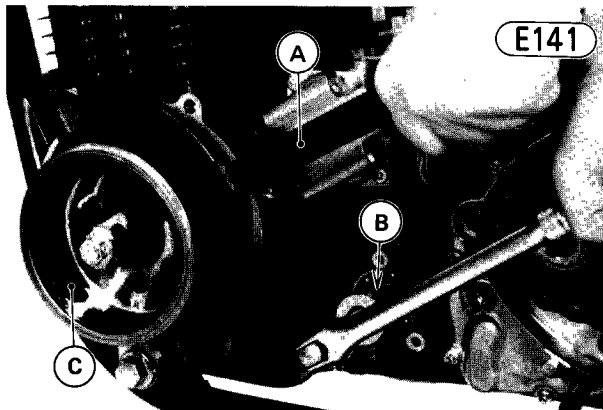

A. Rotor Holder (57001-308) **C. Alternator Rotor**
B. Secondary Shaft Nut

- Tap the secondary shaft from the left side of the crankcase until the right bearing comes out of place. There is a collar in the left bearing.

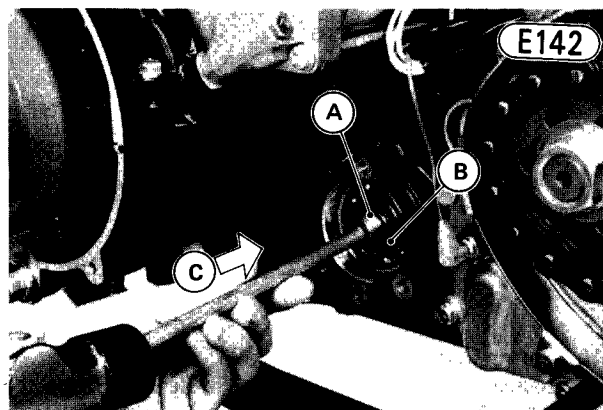

A. Secondary Shaft **B. Collar** **C. Tap**

- Holding the secondary sprocket and starter motor

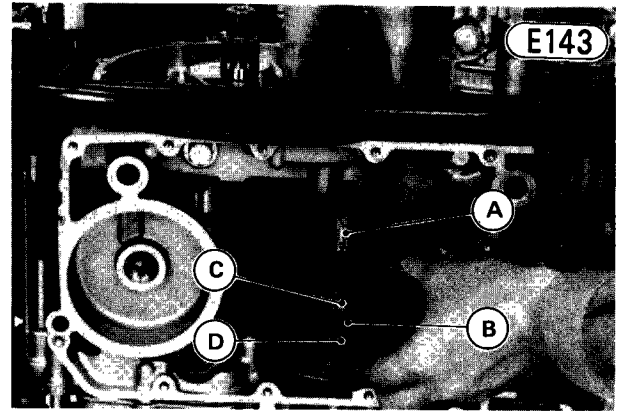

A. Secondary Shaft
B. Secondary Sprocket
C. Starter Motor Clutch Assembly
D. Primary Chain

- Slip the secondary sprocket and starter motor clutch assembly from the primary chain, and take them out.
- Remove the secondary shaft gear circlip. Using the gear puller and adapter (special tools), pull the secondary shaft gear off the shaft.

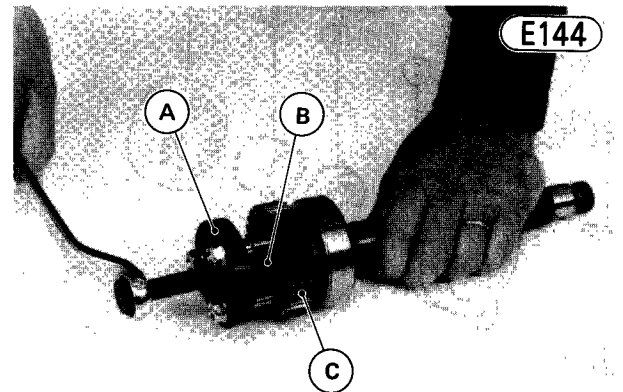

A. Gear Puller (57001-319) **C. Secondary Shaft Gear**
B. Adapter (57001-317)

Installation:

- Check that the starter clutch rollers (3) are in place.

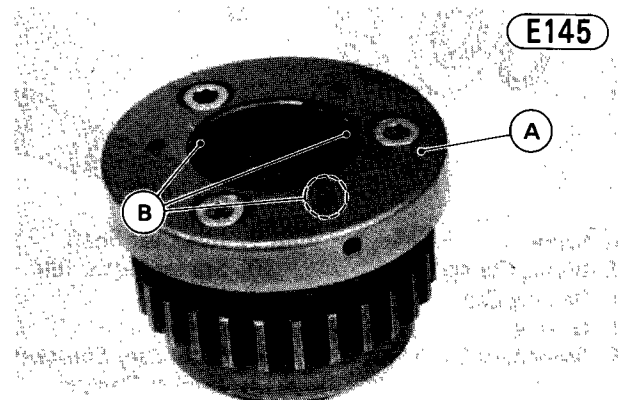

80 DISASSEMBLY—ENGINE INSTALLED

- Put the thrust washer, starter motor clutch, and needle bearing into the secondary sprocket and starter motor clutch assembly.
- Fit the primary chain on the secondary sprocket.

- Put the thrust washer on the secondary shaft, and put the secondary shaft into the secondary sprocket and starter motor clutch assembly, fitting their splines.

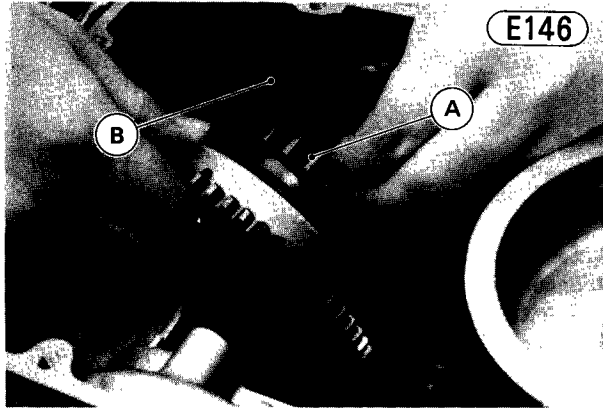

A. Secondary Sprocket

B. Primary Chain

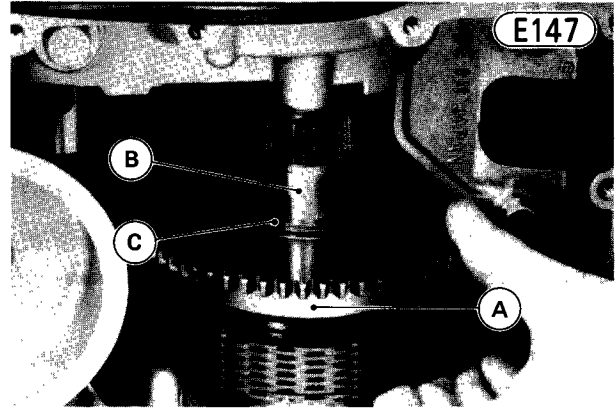

A. Starter Clutch Assembly

B. Secondary Shaft

C. Thrust Washer

Secondary Shaft, Starter Motor Clutch

E148

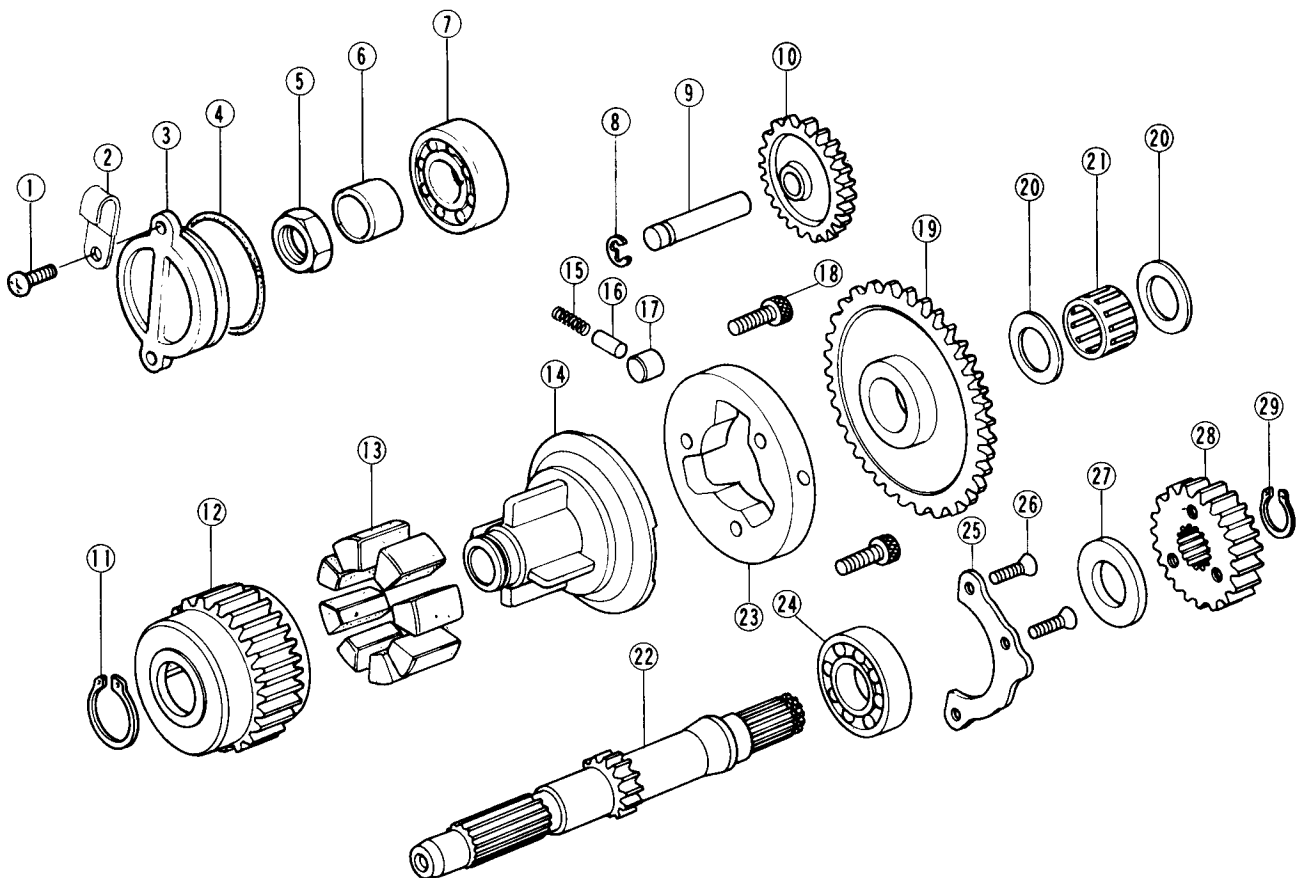

1. Screw
2. Wiring Clamp
3. Bearing Cap
4. O Ring
5. Secondary Shaft Nut
6. Collar
7. Ball Bearing

9. Idle Gear Shaft
10. Starter Motor Idle Gear
11. Circlip
12. Secondary Sprocket
13. Rubber Damper
14. Inner Coupling

15. Spring Cap
16. Spring Cap
17. Roller
18. Allen Bolt
19. Starter Clutch Gear
20. Thrust Washer
21. Needle Bearing
22. Secondary Shaft

23. Ball Bearing
24. Ball Bearing
25. Bearing Stop
26. Screw
27. Thrust Washer
28. Secondary Shaft Gear
29. Circlip

- Install the left bearing collar.
- Using the bearing driver (special tool), tap the secondary shaft bearing into the crankcase with the secondary shaft until the bearing stops at the bottom of the crankcase bearing hole.

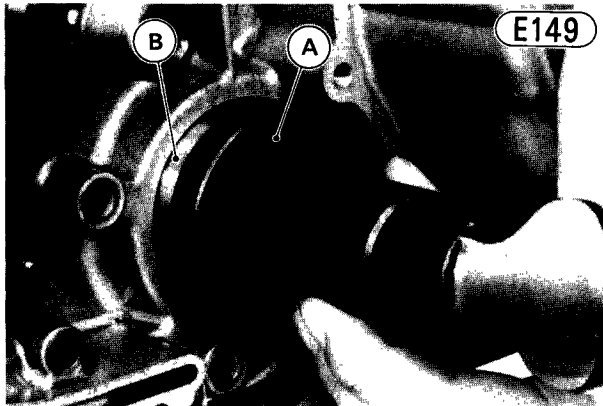

A. Bearing Driver (57001-297)
B. Secondary Shaft Bearing

- Put the large flat washer on the secondary shaft.
- Apply a little oil on the secondary shaft and between the secondary shaft gear and gear pusher (special tool). If necessary, using the rotor holder (special tool) to keep the crankshaft and secondary shaft from turning, push the secondary shaft gear on the shaft by rotating the gear pusher (special tool).

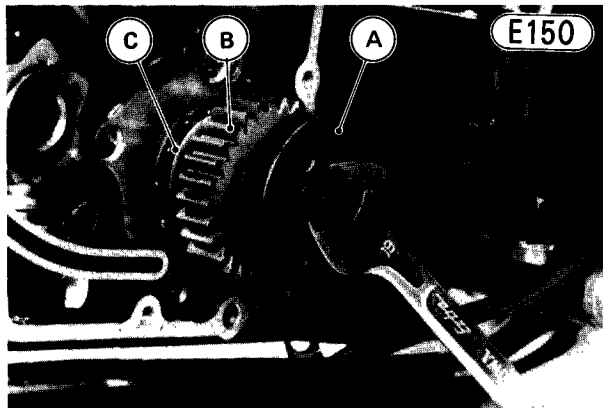

A. Gear Pusher (57001-319)
B. Secondary Shaft Gear
C. Flat Washer

- Install the circlip on the secondary shaft.
- Install the oil pump, oil pan, and oil filter according to the oil pump installation (Pg. 78).
- Check that the left bearing collar is in place, and tighten the secondary shaft nut to 6.0 kg-m (43 ft-lbs) of torque by holding the alternator rotor with the rotor

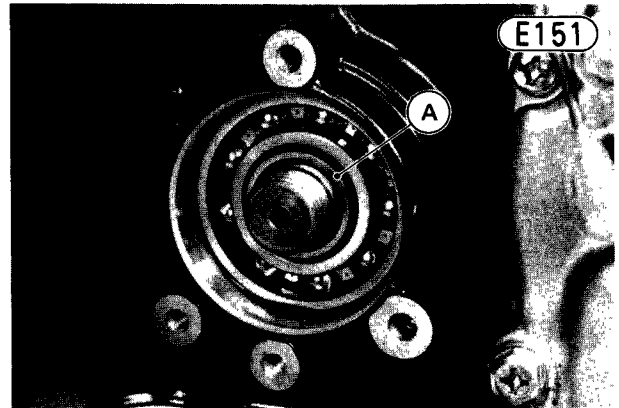

A. Collar

- Install the secondary shaft bearing cap, and tighten its screws (2). The upper screw has a wiring clamp.
- Install the alternator cover.
- Install the clutch (Pg. 75).
- Install the engine sprocket cover (Pg. 65).
- Install the mufflers (Pg. 51).
- Fill the engine with oil and check the oil level (Pg. 19).

Disassembly:

- Pull off the starter clutch gear (19), needle bearing (21), and flat washer (20).
- Remove the rollers (17), springs (15), and spring caps (16) (3 ea) from the starter motor clutch.
- Remove the circlip (11), and pull off the secondary sprocket (12). There are rubber dampers (13) (8).
- Holding the secondary shaft coupling steady, remove the Allen bolts (18) (3) to separate the coupling and starter motor clutch.
- Remove the right ball bearing (24) using the bearing puller and adapter (special tools).

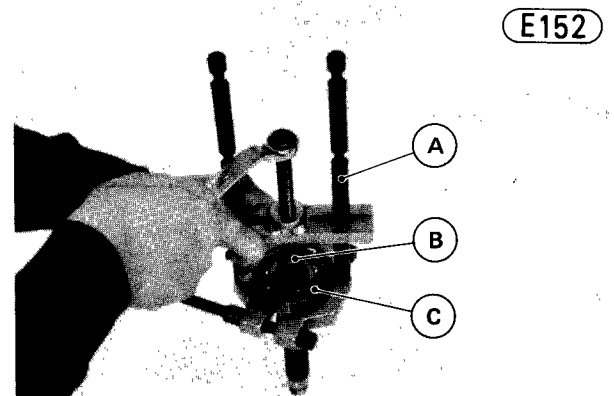

A. Bearing Puller (57001-135)
B. Adapter (57001-317)

C. Ball Bearing

- Using the bearing driver and bearing driver holder (special tools), tap the left ball bearing (7) off the

82 DISASSEMBLY—ENGINE INSTALLED

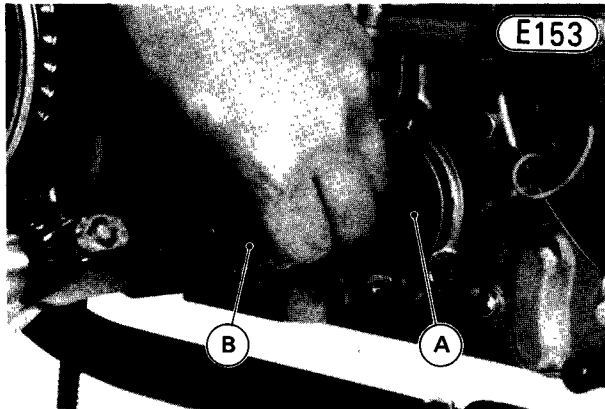

A. Bearing Driver (57001-289)
B. Bearing Driver Holder (57001-139)

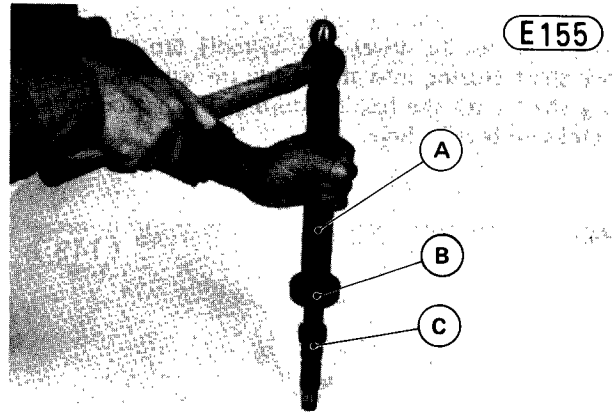

A. Transmission Circlip Driver (57001-380)
B. Ball Bearing
C. Secondary Shaft

Assembly Notes:

1. Check the rubber dampers (8), and replace them with new ones if damaged.
2. Apply a little oil on the rubber dampers (8) to assemble the secondary sprocket and coupling.
3. Apply a non-permanent locking agent to the starter clutch Allen bolts (3), and tighten the bolts to 3.5 kg-m (25 ft-lbs) of torque.
4. Install the left ball bearing using the same special tools (P/N: 57001-289, 57001-139) until it is 10.7 ~11.3 mm deeper than the crankcase surface.

Ball Bearing Installation

E154

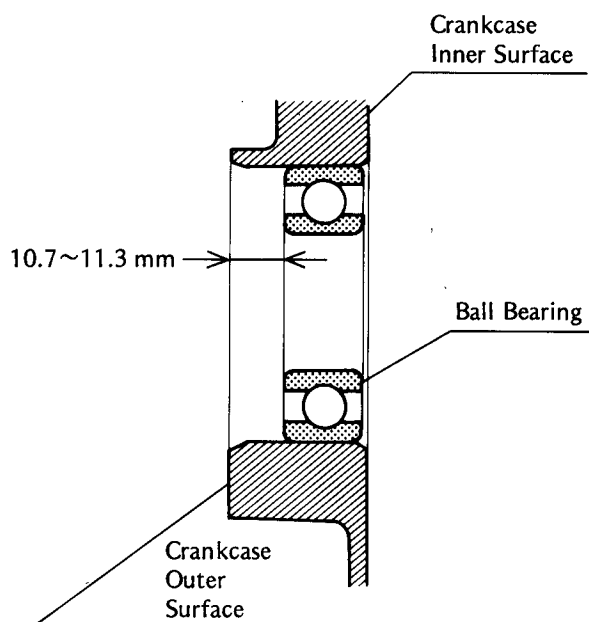

STARTER MOTOR IDLE GEAR

Removal:

- Remove the secondary shaft and starter motor clutch (Pg. 78).
- Remove the circlip, pull off the shaft, and remove the idle gear.

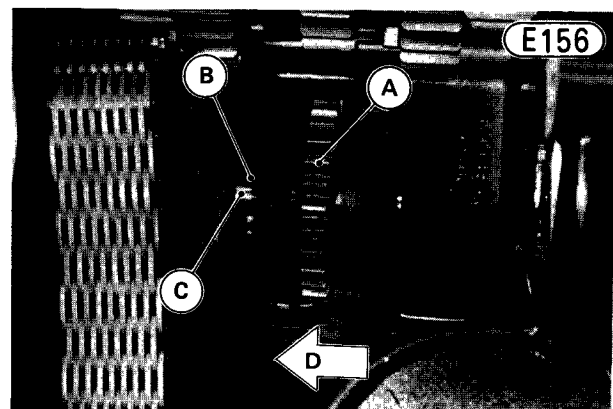

A. Idle Gear
B. Circlip
C. Shaft
D. Left Side

5. Install the right ball bearing using the transmission

Installation Note:

- The idle gear must be installed so that the short end of

Disassembly—Engine Removed

Table of Contents

FLOW CHARTS	84
ENGINE REMOVAL	86
CRANKCASE SPLIT	89
TRANSMISSION	98
Shift Drum	101
Drive Shaft	101
Output Shaft	102
CRANKSHAFT, CAMSHAFT CHAIN, PRIMARY CHAIN	103
CONNECTING RODS	104

86 DISASSEMBLY—ENGINE REMOVED

ENGINE REMOVAL

Removal:

- With the motorcycle up on its center stand, place an oil pan beneath the engine, and remove the engine drain plug and oil filter to drain out the oil.

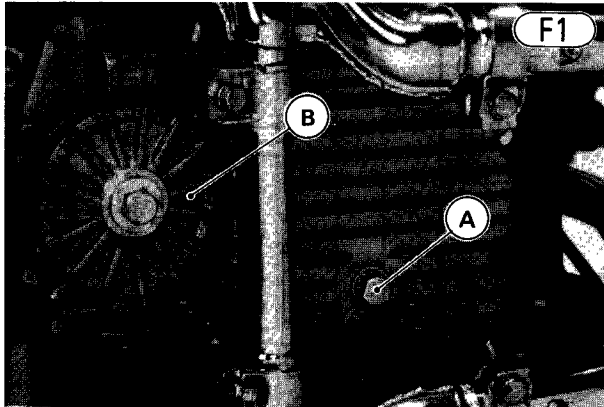

A. Engine Drain Plug B. Oil Filter

- After draining the oil, replace the drain plug with its aluminum gasket, tighten the plug to 3.8 kg-m (27 ft-lbs) of torque, and install the oil filter tightening its bolt to 2.0 kg-m (14.5 ft-lbs) of torque.
- Remove the fuel tank (Pg. 43).
- Take off the right and left side covers.
- Remove the ignition coils (Pg. 51).
- Remove the vacuum switch valve (Pg. 51: US model).
- Remove the screw and flat washer, and open the electrical panel cover.

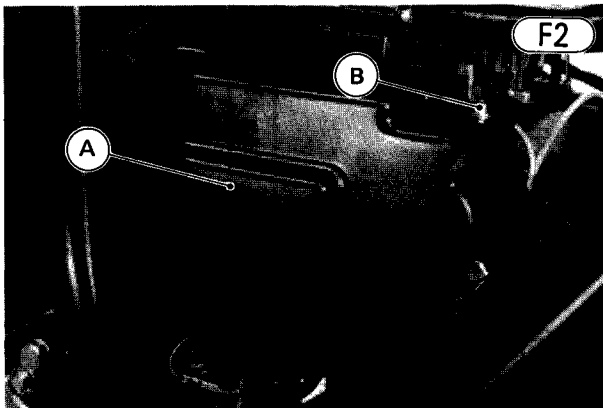

A. Electrical Panel Cover B. Screw

- Remove the electrical panel mounting bolts (2). Each

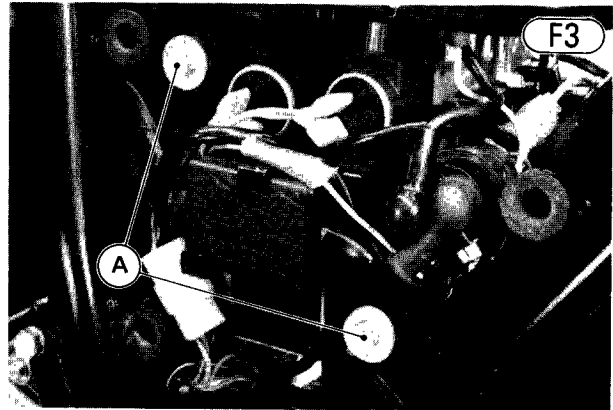

A. Electrical Panel Mounting Bolts

- Remove the air cleaner element cap.
- Remove the air cleaner housing mounting bracket bolts, lockwashers, and flat washers from both sides of the battery housing. Remove the mounting brackets.

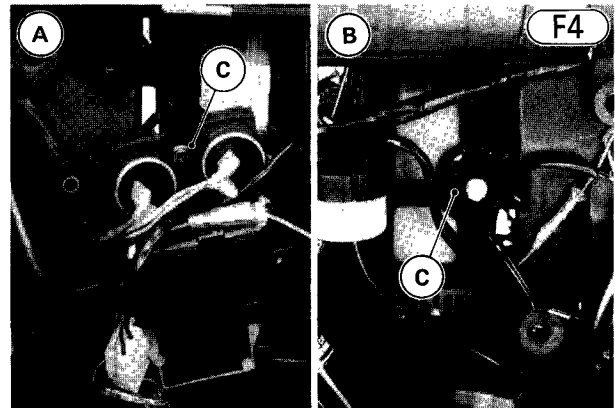

A. Left Side B. Right Side
C. Mounting Bracket

- Remove the carburetors (Pg. 45).
- Slide the clip out of place, and remove the breather hose from the breather cover.

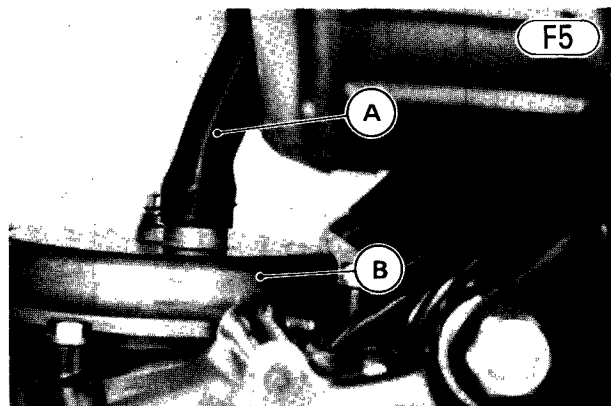

- Remove the air cleaner housing.
- Remove the left footpeg nuts and flatwashers, and remove the footpeg.
- Check to see that the transmission is in neutral, then take out the shift pedal bolt, and remove the shift pedal.

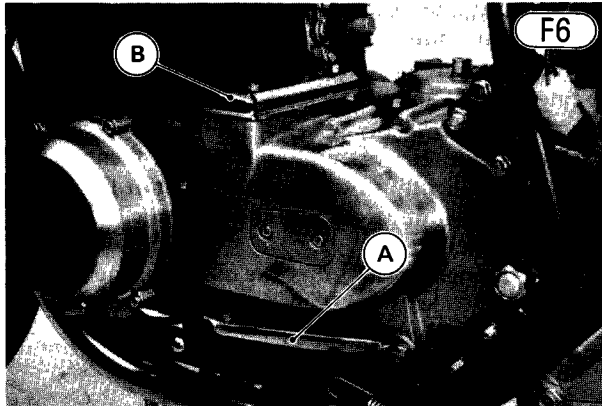

A. Shift Pedal B. Starter Motor Cover

- Remove the bolts (2) and flat washers (2), and remove the starter motor cover.
- Remove the clutch cable clamps from the frame.
- Remove the engine sprocket cover bolts (4), and pull the cover free from the crankcase.
- Loosen the knurled locknut on the clutch lever holder, and screw in the adjuster.
- Line up the slots in the clutch lever, locknut, and adjuster and then free the cable from the lever.
- Free the clutch cable and engine sprocket cover from the frame.
- Pull out the engine sprocket cover knock pins (2), if they are still in the engine.

NOTE: This prevents the knock pin from catching the engine mounting bracket when the engine is lifted up.

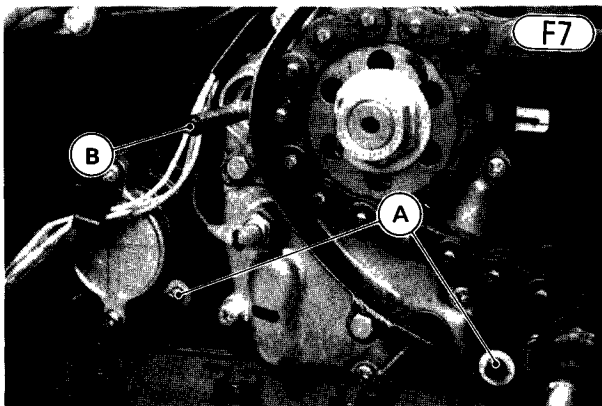

A. Knock Pins B. Clutch Push Rod

- Take the clutch push rod off the crankcase.
- Slide the rubber cap out of place, remove the nut and lockwasher, and free the starter motor lead from the

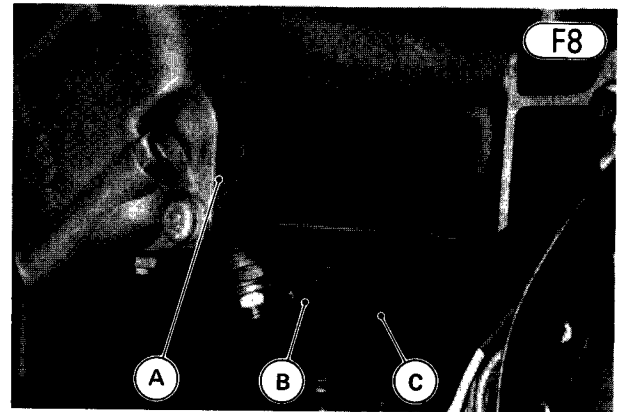

A. Starter Motor C. Rubber Cap
B. Starter Motor Lead

- Disconnect the neutral switch lead from the switch, and disconnect the alternator yellow leads. Free the lead from the engine.

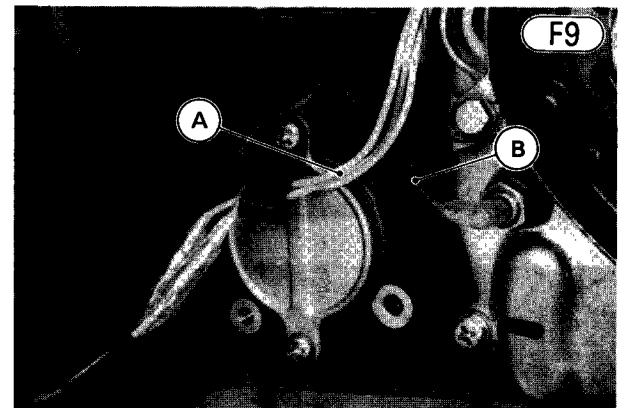

A. Alternator Yellow Leads
B. Neutral Switch Lead

- Remove the mufflers (Pg. 50).
- Remove the rear brake light switch spring.
- Disconnect the rear brake light switch leads (blue and brown).

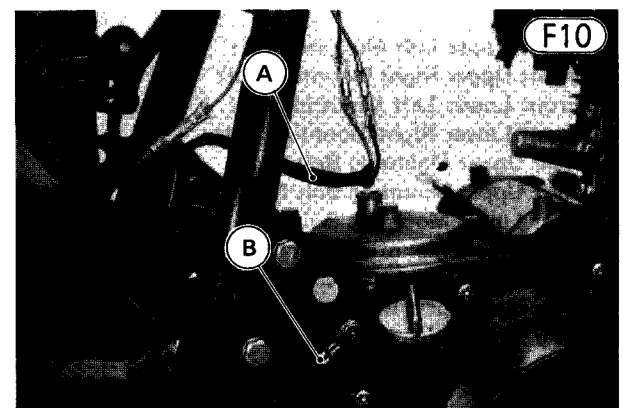

A. Rear Brake Light Switch Leads

88 DISASSEMBLY—ENGINE REMOVED

- Remove the bolt and lockwasher, and remove the battery negative ground lead from the engine.
- Disconnect the pick-up coil 4-pin connector, and oil pressure switch lead, and free the leads from the frame.
- Remove the engine sprocket (Pg. 66).
- Note the position of the brake pedal position so that it can later be installed in the same position. Remove the brake pedal bolt and brake pedal.
- Remove the nuts and flatwashers, and remove the right footpeg.
- Unscrew the tachometer cable from the cylinder head and pull off the cable from the cylinder head.
- Jack or lever the engine up slightly to take the weight off the mounting bolts.
- Remove the engine mounting bolt nuts (6), (8).

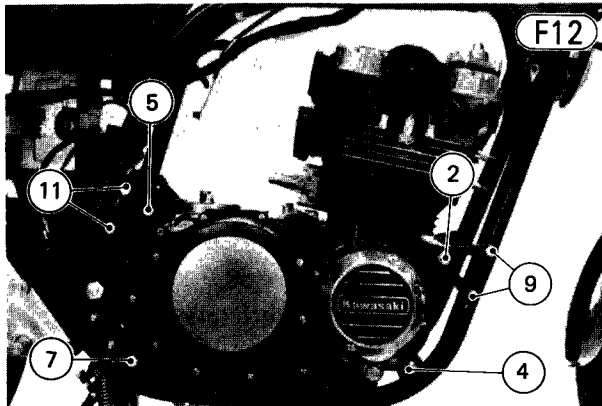
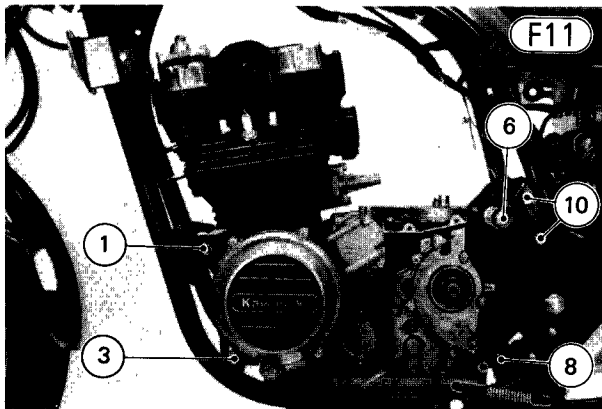

1. Front Upper Left Mounting Bolt
2. Front Upper Right Mounting Bolt
3. Front Lower Left Mounting Bolt
4. Front Lower Right Mounting Bolt
5. Rear Upper Mounting Bolt
6. Rear Upper Mounting Bolt Nut
7. Rear Lower Mounting Bolt
8. Rear Lower Mounting Bolt Nut
9. Front Upper Right Bracket Bolts
10. Rear Upper Left Bracket Bolts
11. Rear Upper Right Bracket Bolts

- Remove the engine mounting bolts (1), (2), (3), (4).
- Remove the front upper mounting bracket bolts (9),

- Remove the rear upper mounting bracket bolts (11) and lockwashers, and remove the bracket with the rear brake light switch.
- Pull out the engine mounting bolts (5), (7). Be careful not to damage the threads upon removal. The rear upper mounting bolt has a spacer.
- Make sure that the following cables and leads are free, and properly positioned on the engine and frame so that they will not get damaged during engine removal: starter lead, clutch cable, tachometer cable, pick-up coil leads, battery negative ground lead, alternator wiring, neutral and oil pressure switch leads, and throttle cable.
- Lift the engine straight up keeping it level, then move it to the right slightly so the rear and front of the engine slips over the lower right rear and the lower right front engine mounts.
- Lift up the right side so that the oil pan at the bottom of the engine clears the frame, and pull the engine out to the right side.

Installation:

- Place the engine into the frame the reverse of how it was removed.
- Install the rear upper and the front upper mounting brackets, and tighten four bracket bolts (9), (11) loosely. The rear two bolts and front two nuts have lockwashers.
- Lifting the engine as necessary so that the mounting bolt threads do not get damaged, insert the six engine mounting bolts and tighten them loosely. The rear upper mounting bolt (5) has a spacer.

Table F1 Engine Mounting Bolt Length and Torque

Bolt		Length	Torque
Front Upper Mounting Bolts	Left (1)	72 mm	4.0 kg-m (29 ft-lbs)
	Right (2)	46 mm	
Front Lower Mounting Bolts	Left (3)	84 mm	
	Right (4)		
Rear Upper Mounting Bolt (5)		250 mm	2.4 kg-m (17.5 ft-lbs)
Rear Lower Mounting Bolt (7)		225 mm	
Front Upper Right Bracket Bolts (9)	Upper	63 mm	2.4 kg-m (17.5 ft-lbs)
	Lower	59 mm	
Rear Upper Bracket Bolts	Left (10)	40 mm	2.4 kg-m (17.5 ft-lbs)
	Right (11)		

- Tighten four bracket bolts and six engine mounting bolts to specified torque as shown in Table.
- Install the push rod, applying a thin coat of a molybdenum disulfide engine assembly grease to its surface.
- Connect the alternator leads.
- Connect the neutral switch light green lead to the switch terminal.
- Fit the starter lead to the starter motor. After tightening the nut, slide the rubber cap back onto the

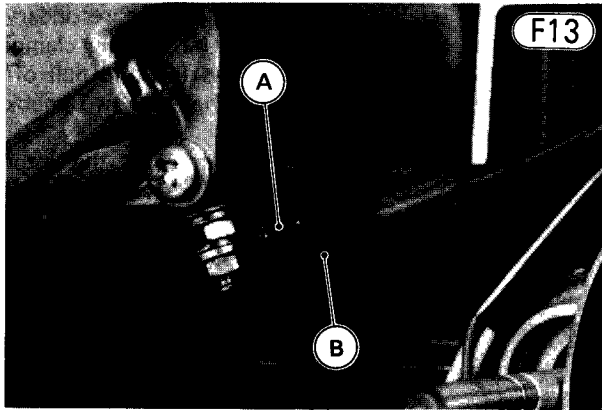

A. Starter Motor Lead **B. Rubber Cap**

- Install the brake pedal in its original position.
- Install the engine sprocket (Pg. 67).
- Adjust the drive chain (Pg. 23).
- Run the clutch cable between the left down tube and the lower part of the engine, and run the upper end of the cable between the left front fork and head pipe.
- Fit the tip of the cable back into the clutch lever.
- Fasten the clutch cable to the frame down tube with the clamps.
- Fit the engine sprocket cover knock pins (2).
- Install the engine sprocket cover, starter motor cover, shift pedal, and left footpeg (Pg. 65).
- Install the right footpeg.
- Check the harness of the pick-up coil leads is clamped.

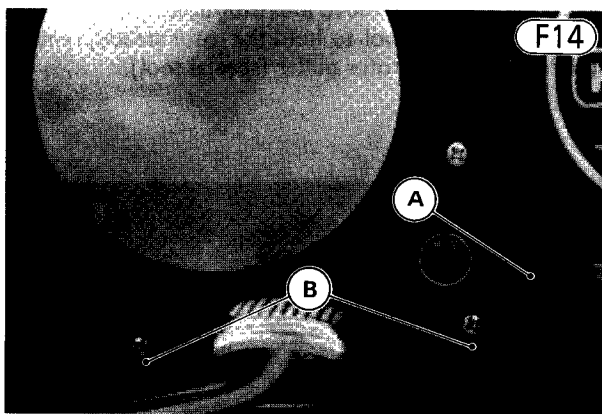

A. Pick-up Coil Leads **B. Clamps**

- Connect the pick-up coil lead 4-pin connector and oil pressure switch lead (blue/red).
- Connect the rear brake light switch leads (blue and brown).
- Install the battery negative ground lead on the engine right side tightening its bolt. The bolt has a lock-washer.
- Install the air cleaner housing, and put the mounting brackets into both sides of the housing. Install the bracket bolts, lockwashers, and flat washers with finger tight. The bracket bolts are tightened after

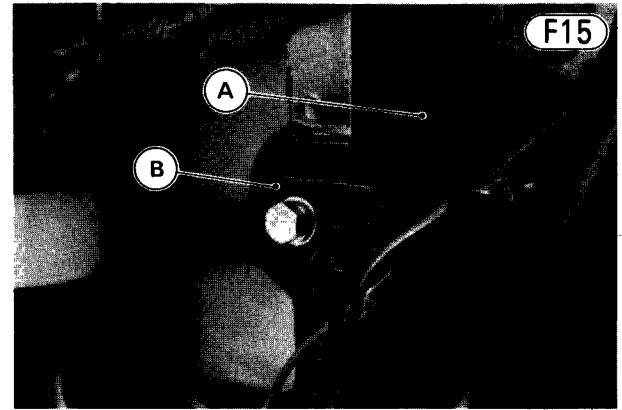

A. Air Cleaner Housing **B. Mounting Bracket**

- Check that the air cleaner element is fitted in the correct position, and install the air cleaner element cap.
- Fit the breather hose onto the breather cover, slide back the clip.
- Put on the carburetor holder clamps (4).
- Install the carburetors (Pg. 46).
- Fix the air cleaner housing to battery housing with the left and right side bracket bolts.
- Install the electrical panel with its mounting bolts.
- Tighten the electrical panel cover screw and flat washer.
- Install the vacuum switch valve (Pg. 52).
- Install the ignition coils (Pg. 51).
- Install the tachometer cable lower end onto the cylinder head.
- Install the mufflers (Pg. 51).
- Install the fuel tank (Pg. 43).
- Push the seat back down.
- Fit the right and left side covers.
- Install the rear brake light switch spring.
- Adjust the rear brake pedal (Pg. 24).
- Adjust the rear brake light switch (Pg. 25).
- Fill the engine with oil, check the level (Pg. 19), and add more if necessary.
- Adjust the clutch (Pg. 17).
- Adjust the throttle cable (Pg. 14).

CRANKCASE SPLIT

Disassembly:

- Remove the engine (Pg. 86).
- Set the engine on a clean surface or, preferably, into a disassembly apparatus with some means of holding the

90 DISASSEMBLY—ENGINE REMOVED

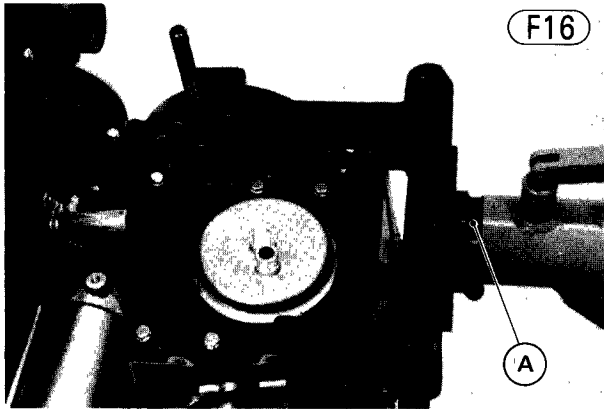

A. Engine Stand (57001-900)

- Remove the starter motor retaining bolts (2), and pull off the starter motor.

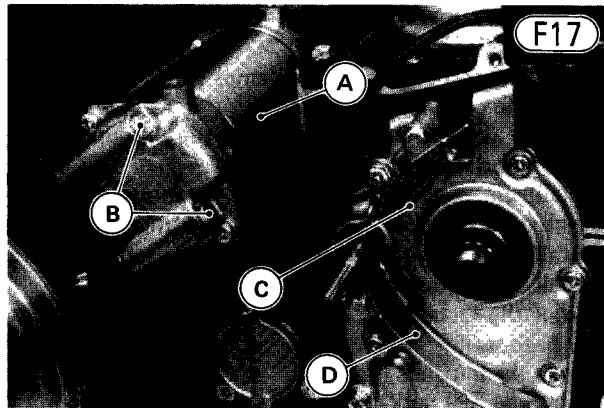

**A. Starter Motor B. Retaining Bolts
C. External Shift Mechanism Cover
D. Drive Chain Guard**

- Remove the bolts (3) and drive chain guard.
- Remove the external shift mechanism cover bolts (2) and screws (5), and pull off the external shift mechanism cover and gasket. There are two knock pins.
- Move the shift arm and overshift limiter out of their positions on the end of the shift drum, and pull out the external shift mechanism.

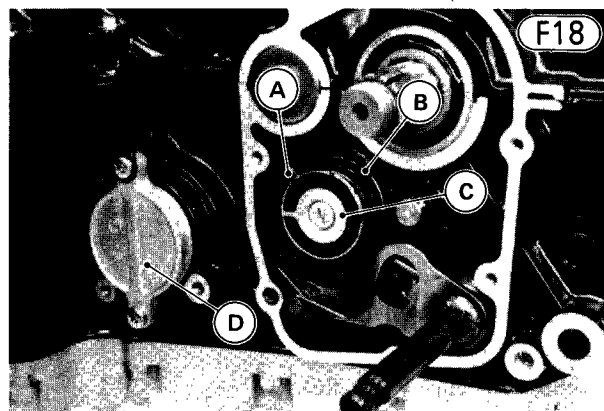

A. Shift Arm C. Shift Drum

- Remove the screws (2), and pull off the secondary shaft bearing cap. The upper screw has a wiring clamp.
- Remove the alternator cover screws (4), and pull off the alternator cover and gasket. There are two knock pins.
- Holding the alternator rotor steady with the rotor holder (special tool), and remove the secondary shaft nut.

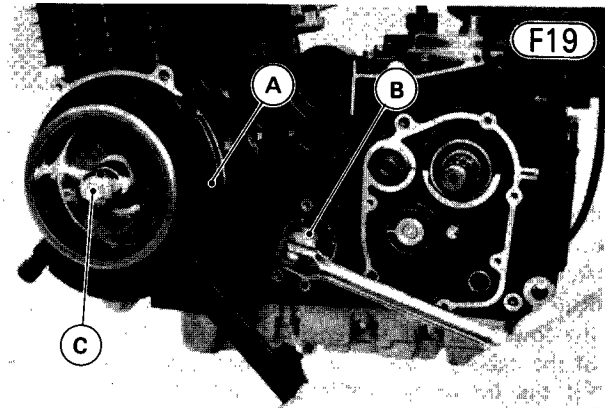

**A. Rotor Holder (57001-308) C. Rotor Bolt
B. Secondary Shaft Nut**

- Remove the alternator rotor according to the following two steps only if the crankshaft is to be removed.
- Hold the alternator rotor steady with the rotor holder (special tool), and remove the rotor bolt.
- Using the special tool to hold the rotor steady, remove the rotor with the rotor puller (special tool).

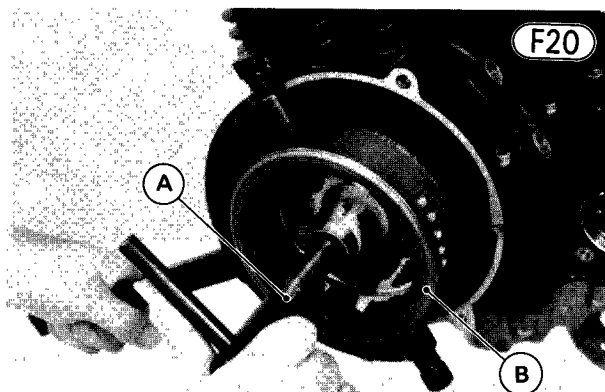

**A. Rotor Puller (57001-254 or 57001-1099)
B. Alternator Rotor**

- Remove the pick-up coil cover and gasket.
- Free the pick-up coil leads from the clamps under the clutch cover.
- Take out the mounting screws, lockwashers, and flat

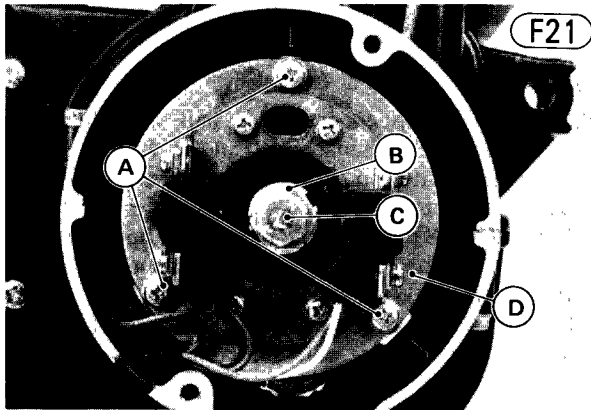

A. Mounting Screws
B. Crankshaft Rotation Nut
C. Timing Advancer Mounting Bolt
D. Pick-up Coil Assembly

- Loosen the oil pressure switch terminal bolt to free the lead, and remove the pick-up coil assembly.
- With a 17 mm wrench on the crankshaft rotation nut to keep the shaft from turning, remove the advancer mounting bolt, and take off the timing advancer.
- Remove the screws (10), and pull off the clutch cover and gasket. There are two knock pins.
- Remove the clutch spring bolts (5), washers (5), and springs (5).

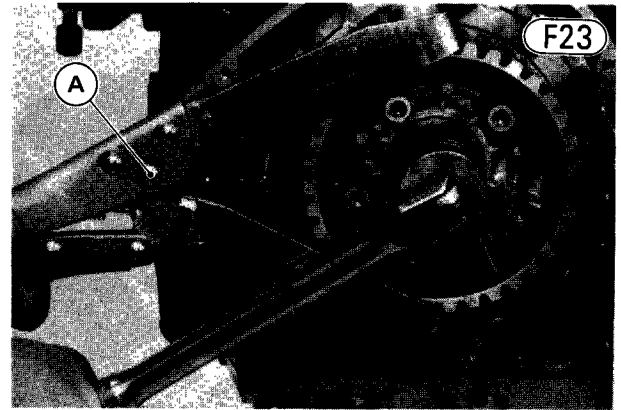

A. Clutch Holder (57001-305)

- Pull off the clutch hub, clutch housing, needle bearing, collar, and large flat washer. There is a thrust washer between the clutch hub and clutch housing.
- Remove the upper crankcase half bolts (13).
- Turn the engine upside down.
- Remove the oil filter mounting bolt, oil filter, and large O ring.
- Remove the oil pan bolts (15), and remove the oil pan, gasket, large O ring, and oil passage O rings (3).
- Remove the secondary shaft bearing stop screws (2). The bearing stop is removed with the secondary shaft.

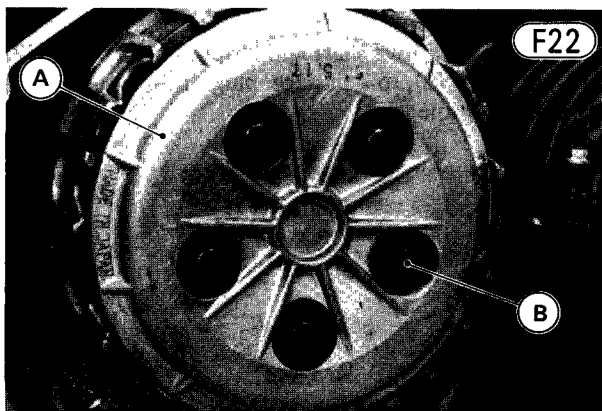

A. Spring Plate **B. Spring Bolt**

- Pull off the spring plate and spring plate pusher.
- Push in the push rod to remove the steel ball, and pull out the push rod.
- Remove the friction plates (7) and steel plates (6).
- Hold the clutch hub from turning using the clutch holder (special tool), and remove the clutch hub

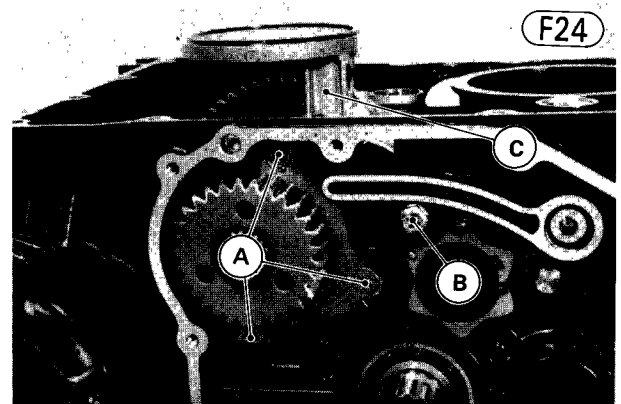

A. Bearing Stop Screws **C. Oil Pump**
B. Oil Pump Bolt

- Remove the engine oil pump bolt, and take off the engine oil pump. There are two knock pins.
- Tap the secondary shaft from the left side of the

92 DISASSEMBLY—ENGINE REMOVED

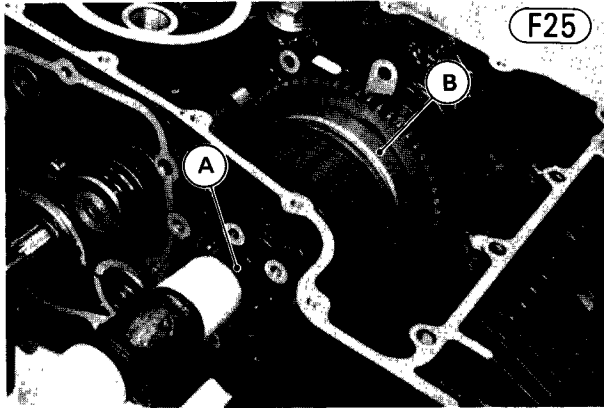

A. Secondary Shaft
B. Starter Motor Clutch Assembly

- Holding the secondary sprocket and starter motor clutch assembly, pull out the secondary shaft.
- Slip the secondary sprocket and starter motor clutch assembly from the primary chain, and take them out.
- Remove the 6 mm lower crankcase half bolts (7) and 8 mm bolts (10).

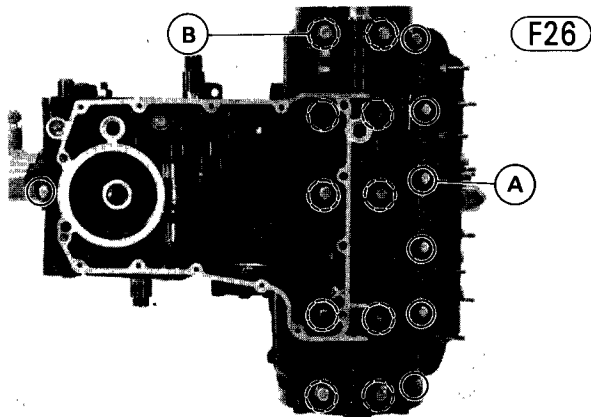

A. 6 mm Bolt **B. 8 mm Bolt**

- Pry the four points to split the two crankcase halves apart, and lift off the lower crankcase half.

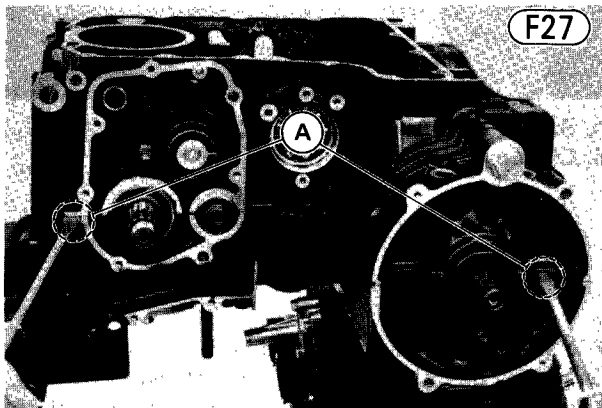

- Take out the drive shaft and output shaft assemblies.

Assembly:

- NOTES:**
1. The upper crankcase half and the lower crankcase half are machined at the factory in the assembled state, so the crankcase halves must be replaced together as a set.
 2. Replace the 8 mm lower crankcase half bolts (10) with new ones if they have already been removed 5 times.
 3. If a new crankshaft, crankcase halves, and/or main bearing inserts are used, select the proper bearing inserts in accordance with the combination of crankshaft and crankcase marks (See Pg. 103).
- Set the shift drum in neutral position as shown.

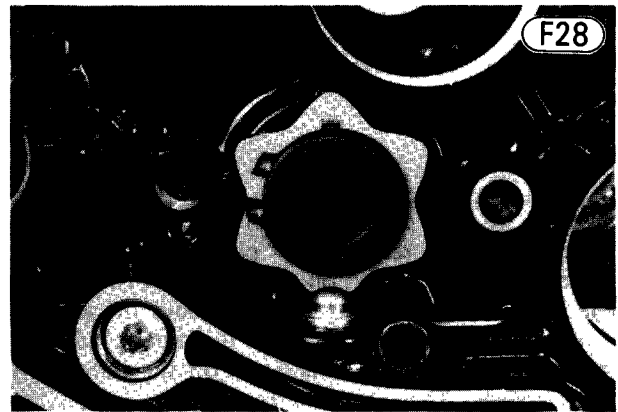

- Check to see that the following parts are in place on both the upper crankcase half and the lower crankcase half, and blow the oil passage nozzles clean with compressed air.

Upper crankcase half:

Knock pins (2); drive shaft and output shaft set rings (2), and set pins (2); oil passage plug (rubber ball); and starter motor idle gear.

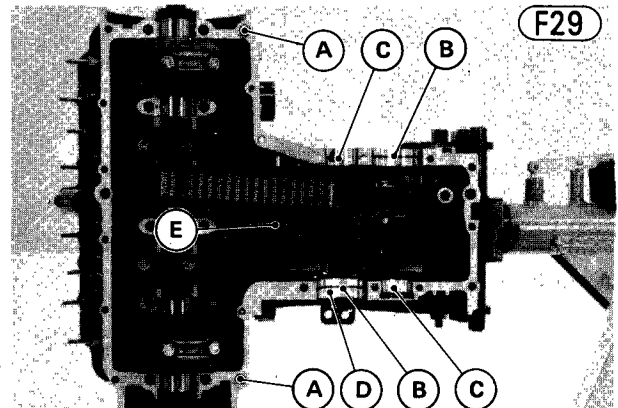

A. Knock Pin **D. Oil Passage Plug**
B. Set Ring **E. Idle Gear**
C. Set Pin

Lower crankcase half:

Oil passage nozzles (2); and crankshaft main bearing

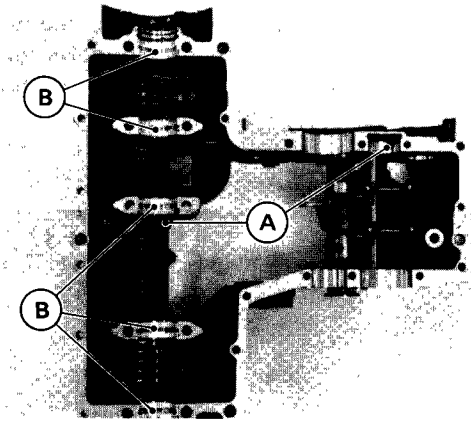

F30

A. Oil Passage Nozzles B. Bearing Inserts

- With a high flash-point solvent, clean off the mating surfaces of the crankcase halves and wipe dry.
- Fit the output and drive shaft assemblies on the upper crankcase half. When installing the output and drive shafts, the crankcase set pins must go into the holes in the respective needle bearing outer races, and the set rings must fit into the grooves in each ball bearing.

CAUTION Make sure the crankcase set pins are properly aligned to avoid damage to the crankcases upon installation.

- Apply a little engine oil to the transmission gears, ball bearings, shift drum, and crankshaft main bearing inserts.
- Check to see that the output shaft 1st gear turns freely. If the gear does not turn freely, replace the steel washer with the thinner (0.5 mm) steel washer. Check the clearance between the drive shaft 2nd gear and the copper washer. The clearance should be 0.1~0.3 mm. If it is not, change and/or add the steel washer(s) to obtain the proper clearance. Three sizes of steel washers (1.0, 0.7, 0.5 mm thick) are available from Kawasaki Dealers.

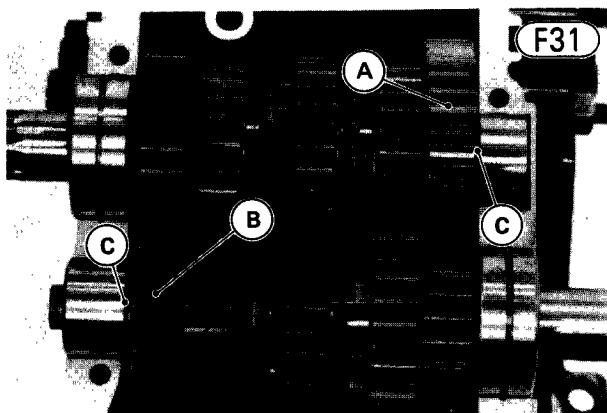

F31

A. Output Shaft 1st Gear B. Drive Shaft 2nd Gear C. Steel Washer

- Apply liquid gasket to the mating surface of the lower crankcase half in the areas shown in Fig. F32.

CAUTION If liquid gasket adheres to any areas not indicated, the engine oil passages may

Liquid Gasket Applied Area (Crankcase)

F32

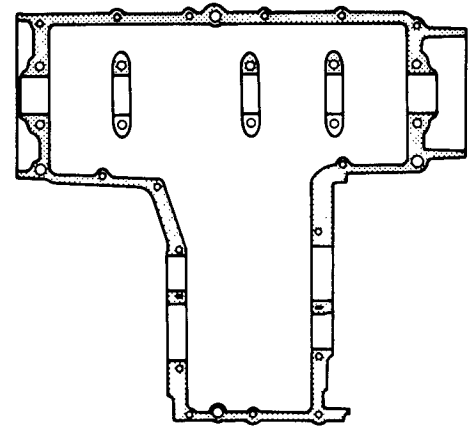

- Fit the lower crankcase half on the upper crankcase half. Each shift fork must fit in its gear groove.

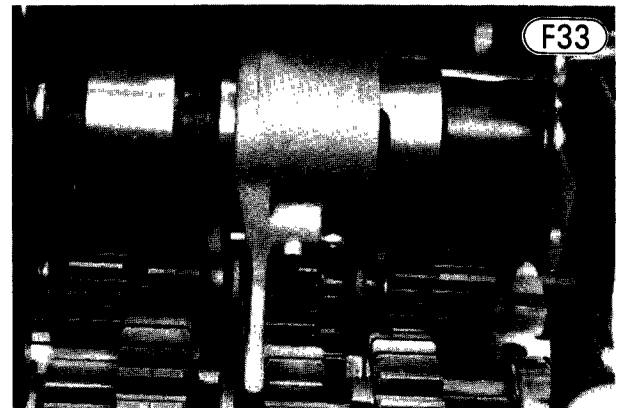

F33

- Install and lightly tighten the lower crankcase half 8 mm bolts (10) and 6 mm bolts (7).
- Following the tightening sequence numbers on the lower crankcase half, tightening the 8 mm bolts (10) first to about 1.5 kg-m (11.0 ft-lbs) and finally to 2.5 kg-m (18.0 ft-lbs) of torque.

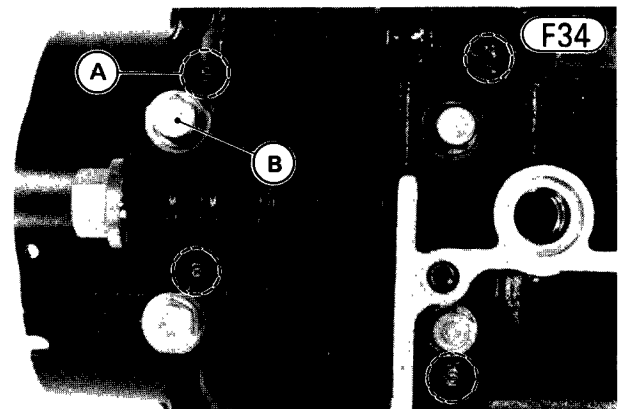

F34

94 DISASSEMBLY—ENGINE REMOVED

- Tighten the 6 mm bolts (7) to 1.0 kg-m (87 in-lbs) of torque.
- Check to see that the drive shaft and output shaft turn freely.
- Install the alternator rotor according to the following two steps only if the rotor was removed.
- Using a high flash-point solvent clean off any oil or dirt that may be on the crankshaft taper or rotor hub, and install the alternator rotor.
- Tighten the bolt to 7.0 kg-m (51 ft-lbs) of torque while holding the alternator rotor steady with the rotor holder (special tool).
- Remove the secondary shaft gear circlip. Using the gear puller (special tool), pull the secondary shaft gear and large flat washer off the shaft.

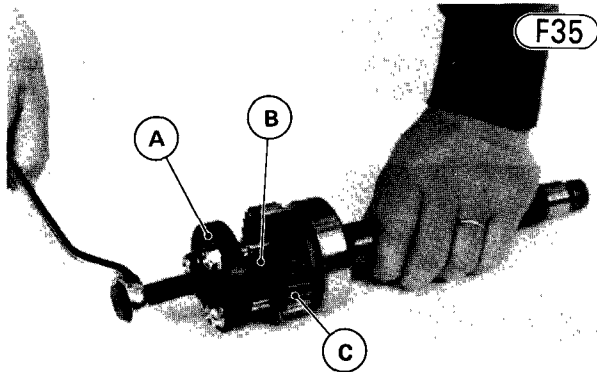

A. Gear Puller (57001-319) **C. Secondary Shaft Gear**
B. Adapter (57001-317)

NOTE: The gear puller (special tool: P/N 57001-319) is also used for installing the secondary shaft gear (See Fig. F41).

- Put the thrust washer and starter motor clutch into the secondary sprocket and starter motor clutch assembly.
- Fit the primary chain on the secondary sprocket.

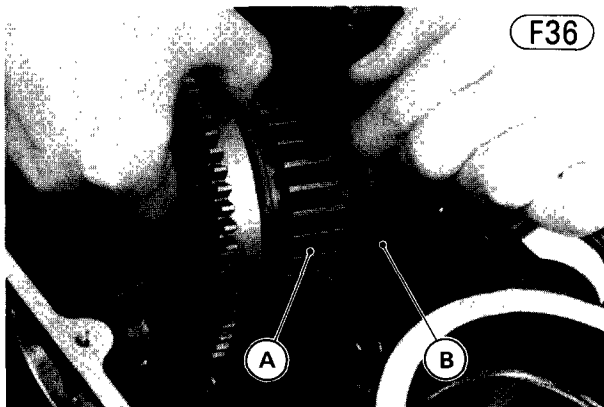

- Put the thrust washer on the secondary shaft, and put the secondary shaft into the secondary sprocket and starter motor clutch assembly, fitting their splines.

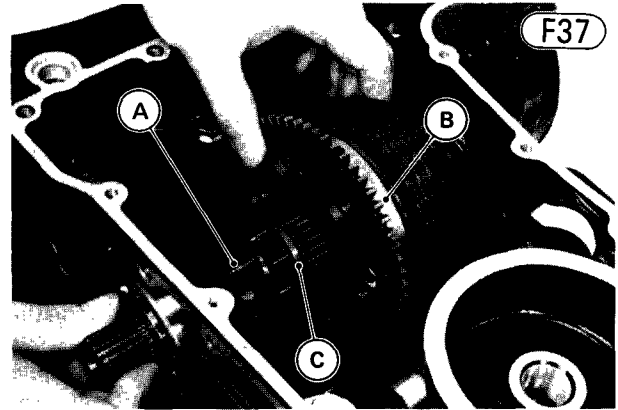

A. Secondary Shaft
B. Starter Motor Clutch Assembly
C. Thrust Washer

- Put the bearing collar into the left secondary shaft bearing.
- Using the bearing driver (special tool), tap the secondary shaft bearing into the crankcase with the secondary shaft until the bearing stops at the bottom of the crankcase bearing hole. Check that the bearing collar is properly fitted in the left bearing.

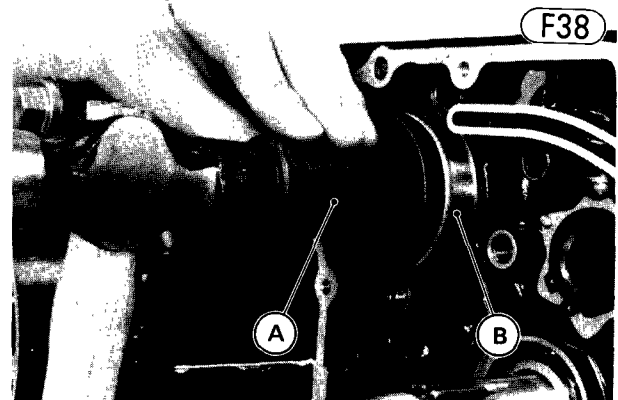

A. Bearing Driver (57001-297)
B. Right Secondary Shaft Bearing

- Check to see that the oil pump knock pins (2) are in place. Install the oil pump, making sure the oil pump gear and pump drive gear at the secondary shaft mesh.

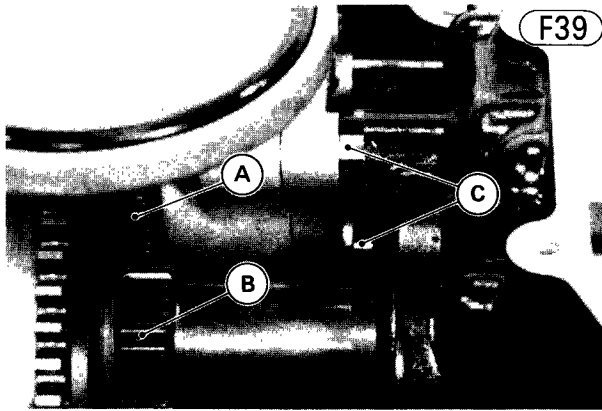

A. Oil Pump Gear **C. Knock Pins**
B. Drive Gear

- Install the secondary shaft bearing stop with the screws (3), stake each screw head with a punch to prevent loosening.

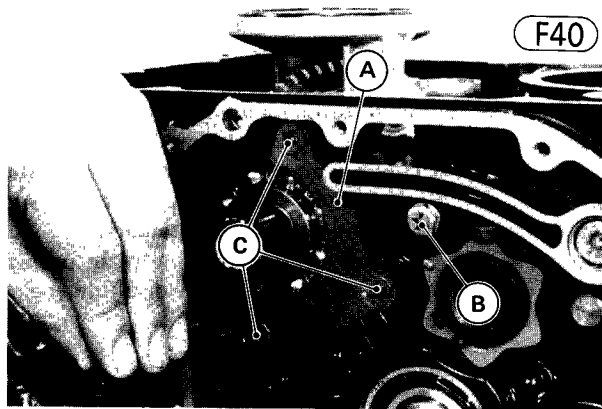

A. Bearing Stop **C. Stop Screws**
B. Oil Pump Bolt

- Put the large flat washer on the secondary shaft.
- Apply a little oil on the secondary shaft and between the secondary shaft gear and gear pusher (special tool). If necessary, using the holder (special tool) to keep the crankshaft and secondary shaft from turning, push the secondary shaft gear on the shaft by rotating the gear pusher (special tool).

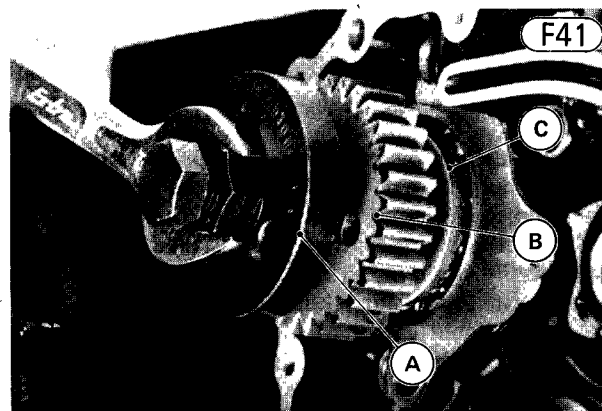

A. Gear Pusher (57001-319) **C. Flat Washer**

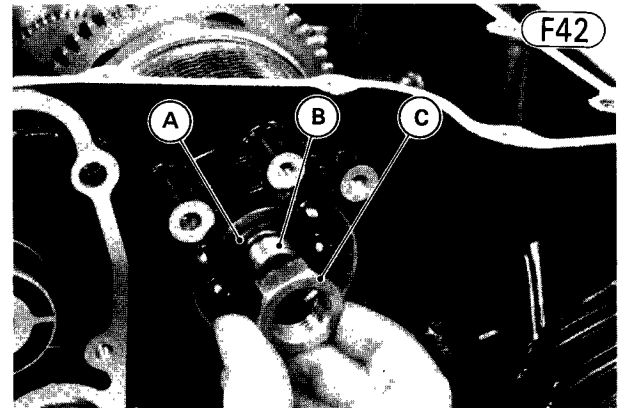

A. Collar **B. Secondary Shaft** **C. Shaft Nut**

- Install the circlip on the secondary shaft.
- Check that the secondary shaft collar is in place.
- Tighten the secondary shaft nut to 6.0 kg-m (43 ft-lbs) of torque while holding the alternator rotor steady with the rotor holder (special tool).
- Install the secondary shaft bearing cap, and tighten its screws (2). The upper screw has a wiring clamp.
- Fit the oil passage O rings (3) on the lower crankcase. Replace the O rings with new ones, if deteriorated or damaged. The flat side of the O ring must face down.

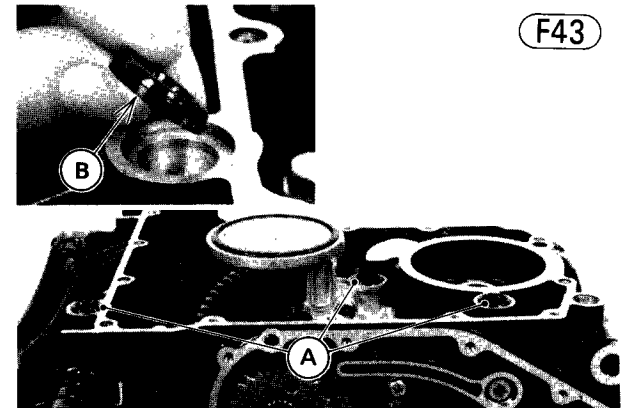

A. Oil Passage "O" Rings **B. Flat Side**

- Check that the large O ring and oil pressure relief valve are in place, and install a new oil pan gasket, and the oil pan with its mounting bolts (15). Tighten the bolts to 1.0 kg-m (87 in-lbs) of torque.

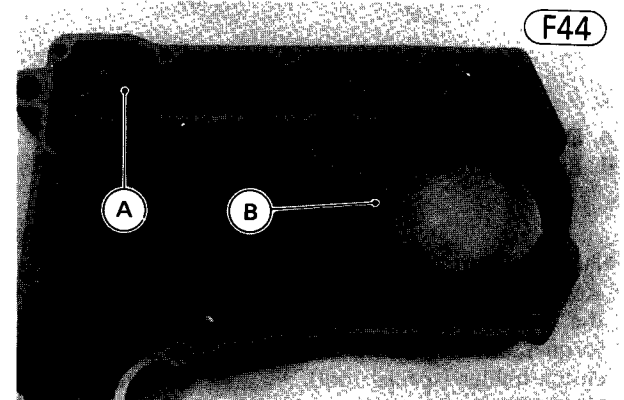

A. O-Ring **B. Oil Pressure Relief Valve**

96 DISASSEMBLY—ENGINE REMOVED

- Check that the large O ring is in place, and install the oil filter, tightening its bolt to 2.0 kg-m (14.5 ft-lbs) of torque.
- Turn the engine right side up.
- Install the upper crankcase bolts (13), and tighten them to 1.0 kg-m (87 in-lbs) of torque.
- Put the clutch housing spacer on the drive shaft. The spacer must be installed with its flat side facing toward the end of the shaft.

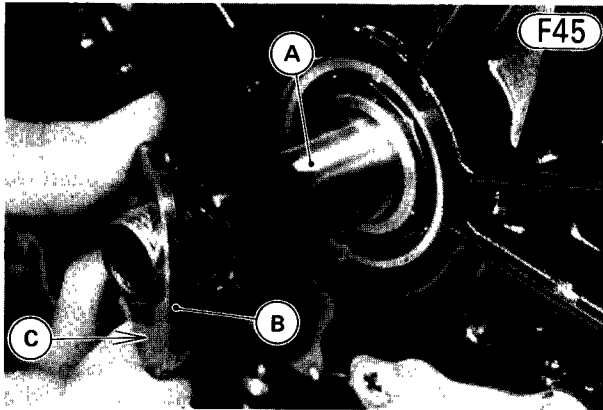

A. Drive Shaft
B. Clutch Housing Spacer
C. Flat Side

- Install the drive shaft sleeve, needle bearing, and clutch housing.

NOTE: The drive shaft sleeve and engine sprocket collar look the same, but the drive shaft sleeve has a small hole.

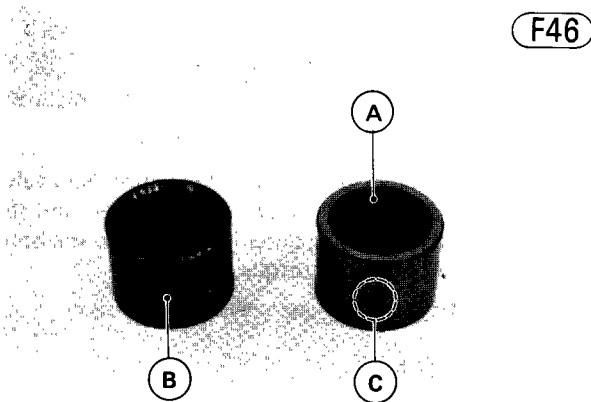

A. Drive Shaft Sleeve
B. Engine Sprocket Collar
C. Small Hole

- Put on the thrust washer, clutch hub, and lockwasher. Replace the clutch hub nut with a new one, screw on the nut and tighten it to 13.5 kg-m (98 ft-lbs) of torque, while holding the hub stationary with the clutch holder (special tool).

WARNING The washer between the clutch hub and the clutch holder must be installed with the

the marked side, "OUTSIDE", facing out (Fig. F74). If this washer is installed backwards, the hub nut might loosen during operation. This causes clutch disengagement, resulting in loss of motorcycle control.

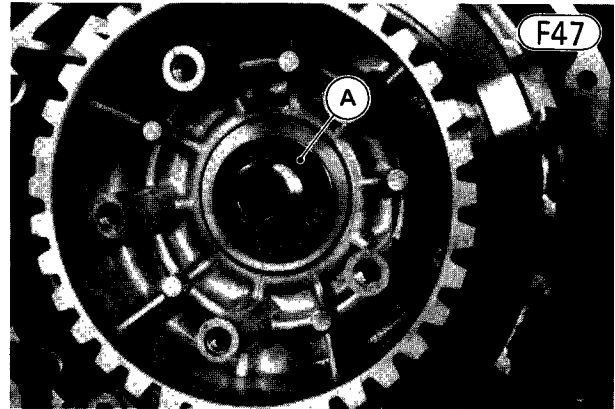

A. Lockwasher

- Install the friction plates (7) and steel plates (6), starting with a friction plate and alternating them.

CAUTION If new dry steel plates and friction plates are installed, apply engine oil to the surfaces of each plate to avoid clutch plate seizure.

- Insert the clutch steel ball, and spring plate pusher, applying a thin coat of molybdenum disulfide engine assembly grease to their surfaces.

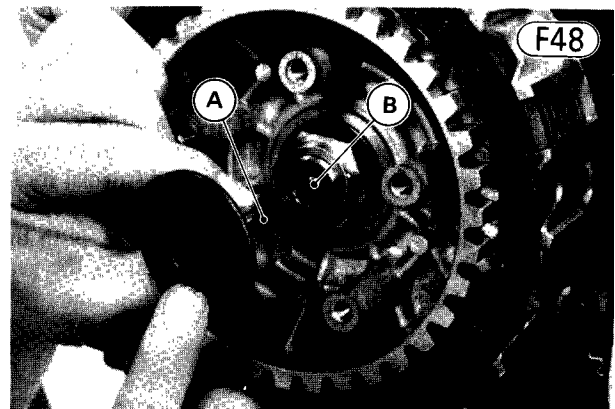

A. Spring Plate Pusher
B. Steel Ball

- Install the spring plate, springs, spring washers, and spring bolts (5 ea). Cross tighten the bolts evenly to 0.90 kg-m (78 in-lbs) of torque.

NOTE: The spring plate can be installed on the clutch hub in any position, so there is no mark on either the spring plate or the clutch hub.

- Apply a liquid gasket to the crankcase halves mating surface on the front and rear sides of the clutch.
- Check that the knock pins (2) are in place, fit the clutch cover onto the crankcase. Tighten the screws (10) firmly. Be sure to include the contact breaker lead wires (9) with the clutch.

- Fit the timing advancer onto the crankshaft, matching its notch with the pin in the end of the crankshaft, and install the crankshaft rotation nut and the advancer mounting bolt. The notches in the nut fit the projections on the timing advancer. Tighten the bolt to 2.5 kg-m (18.0 ft-lbs) of torque.

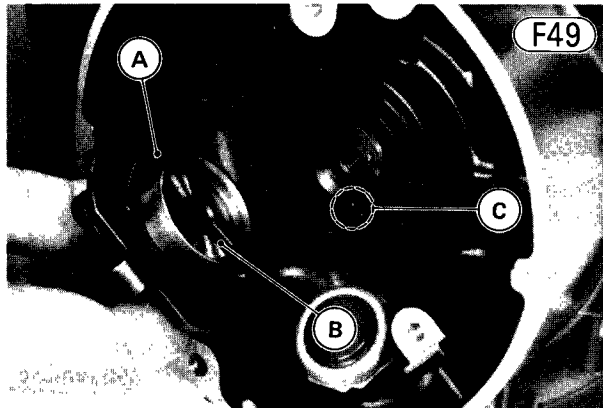

A. Timing Advancer B. Notch C. Pin

- Connect the oil pressure switch lead to the switch terminal.
- Mount the pick-up coil assembly, and tighten its screws (3). Each screw has a lockwasher and flat washer.
- Fit the wiring grommet, and install the gasket and pick-up coil cover with the screws (2).
- Clamp the pick-up coil wiring with the wiring clamps under the clutch cover.
- Check that the external shift mechanism return spring pin is not loose. If it is loose, remove it, apply a non-permanent locking agent to the threads, and re-install it (Fig. E96 on Pg. 68).
- Check that the return spring and pawl spring are properly fitted in place, mount the external shift mechanism, and place its arms on the shift drum pins.

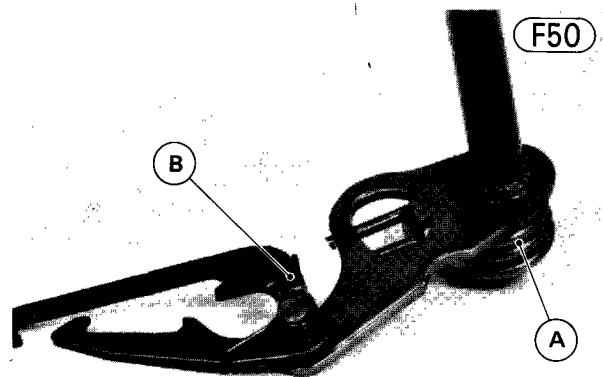

A. Return Spring B. Pawl Spring

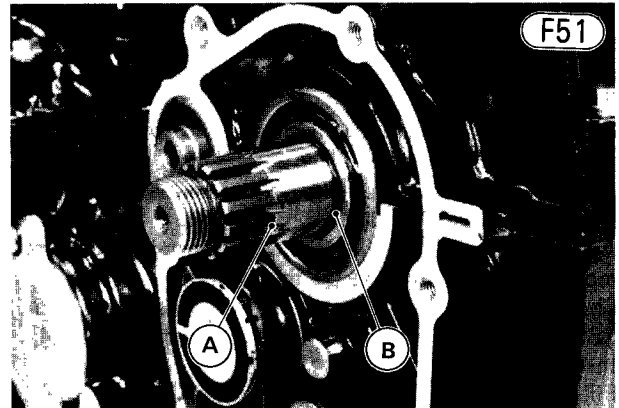

A. Output Shaft B. O Ring

- Apply a high temperature grease to the lips of the clutch push rod oil seal and the output shaft collar oil seal.
- Check that the external shift mechanism cover knock pins (2) are in place.
- Insert the shift shaft oil seal guide (special tool) in the external shift mechanism cover oil seal, install the cover and gasket, and then tighten the bolts (2) and screws (5). Each bolt must be installed with a new aluminium washer.

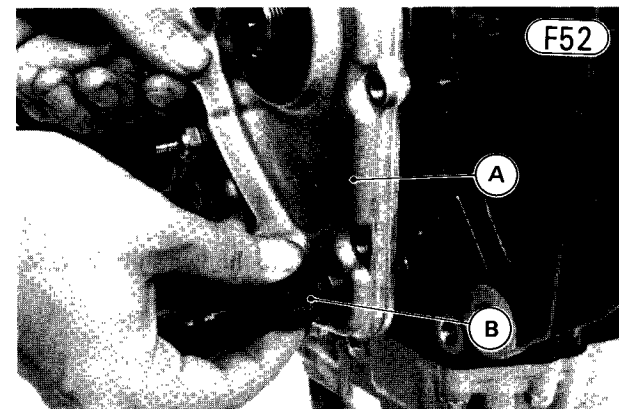

A. External Shift Mechanism Cover
B. Shift Shaft Oil Seal Guide (57001-264)

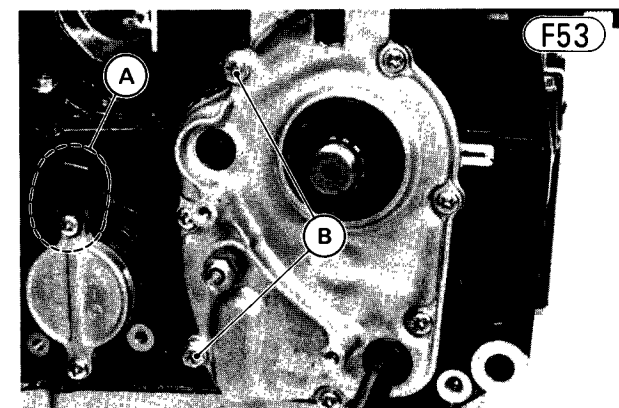

F53

98 DISASSEMBLY—ENGINE REMOVED

- Install the output shaft collar onto the output shaft.
NOTE: The output shaft collar and drive shaft sleeve look the same, but the drive shaft sleeve has a small hole (Fig. F46).
- Apply a non-permanent locking agent to the bolts (3), and install the drive chain guard.
- Clean the starter motor lugs and crankcase where the starter motor is grounded.
- Apply a little oil to the O ring and install the starter motor. Tighten the starter motor retaining bolts (2).
- Check that the knock pins (2) are in place, install the gasket and alternator cover, and tighten the screws (4).
- Install the engine (Pg. 88).
- Fill the engine with oil, check the oil level (Pg. 19), and add more if necessary.
- Carry out the adjustment procedures listed at the end of the engine installation section (Pg. 89).

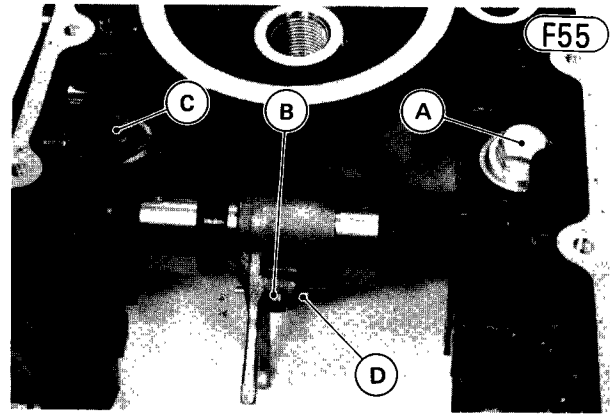

A. Positioning Bolt **C. Guide Bolt**
B. Shift Fork Guide Pin **D. Cotter Pin**

- Straighten the side of the lockwasher that is bent over the side of the shift drum guide bolt, and remove the bolt.
- Remove the cotter pin, and pull out the drive shaft 4th/5th shift fork guide pin.
- Remove the operating plate circlip and operating plate.
- Pull out the shift drum slightly, and remove the drive shaft 4th/5th shift fork. Pull the shift drum free from the crankcase.

TRANSMISSION

Removal:

- Remove the engine (Pg. 86).
- Split the crankcases (Pg. 89).
- Pull out the shift rod, and remove the two shift forks in the lower crankcase half.

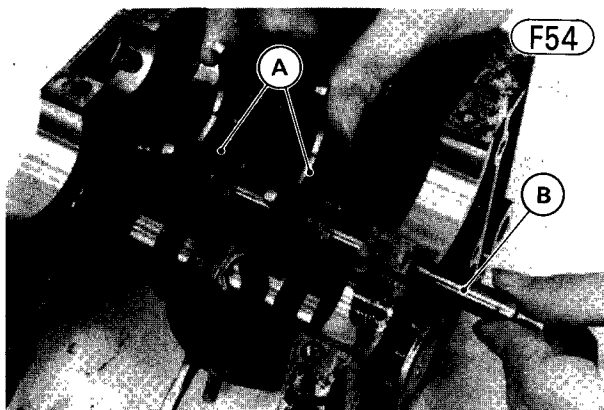

A. Shift Forks **B. Shift Rod**

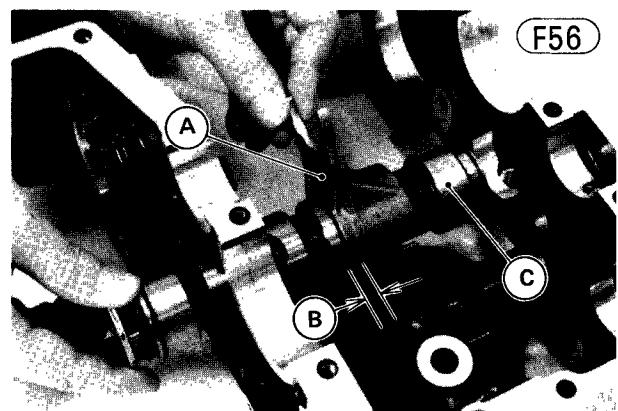

A. 4th/5th Shift Fork **B. Short End** **C. Shift Drum**

- Remove the shift drum positioning bolt, spring and

- Push the shift drum in the rest of the way.
- Check to see that the operating place pin is in place, fit the operating plate onto the end of the shift drum.

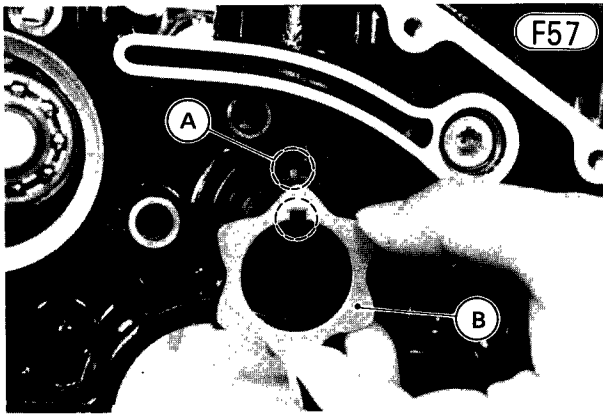

A. Operating Plate Pin B. Operating Plate

- Tighten the shift drum guide bolt, and bend the side of the lockwasher over the side of the bolt. The lockwasher must seat in the crankcase.

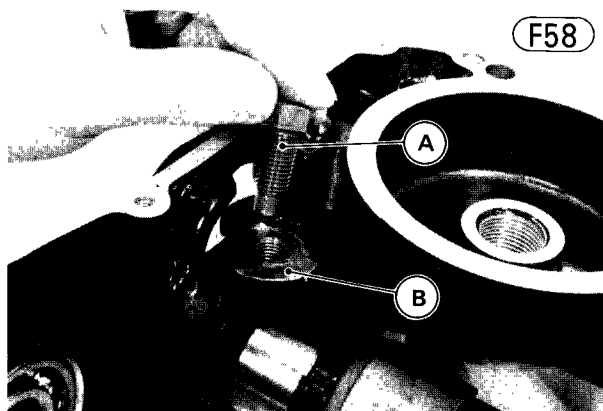

A. Shift Drum Guide Bolt B. Lockwasher

- Put the 4th/5th shift fork guide pin into the 4th/5th shift fork. The guide pin rides in the middle groove of the three guide pin grooves.
- Insert a new cotter pin through the 4th/5th shift fork and guide pin from the long end side of the shift fork, and spread the cotter pin long end inward.

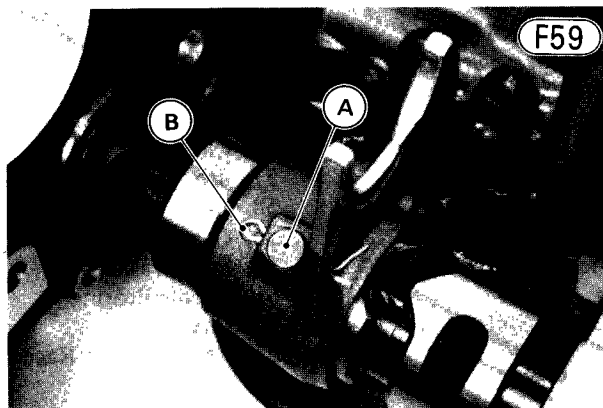

- Install the shift drum positioning pin, spring, and bolt.

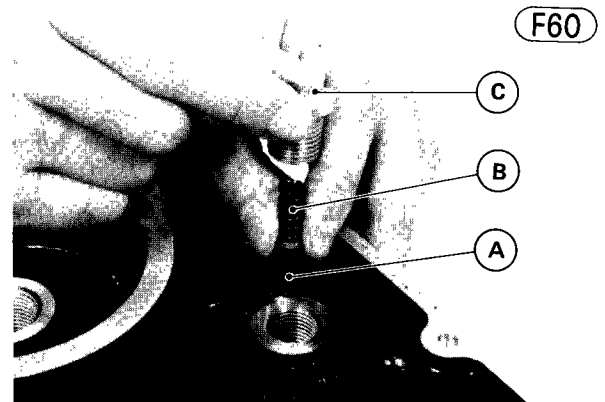

A. Positioning Pin B. Spring C. Bolt

- Set the shift drum in neutral position as shown.

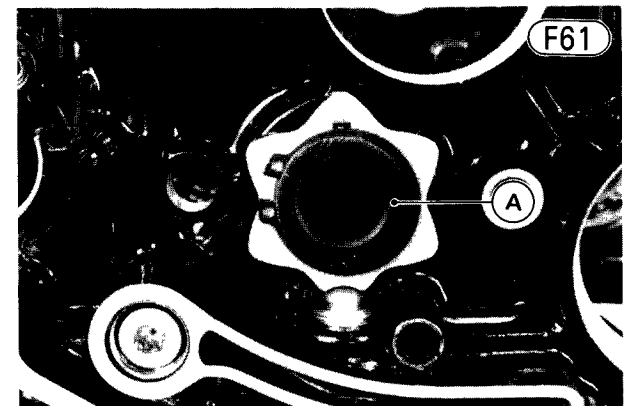

A. Shift Drum

- Apply a little engine oil to the shift rod and shift fork fingers. Insert the shift rod, running it through the output 2nd/3rd shift fork, and then through the output 1st shift fork, fitting each shift fork guide pin into the shift drum groove. The output 2nd/3rd shift fork and 1st shift fork are identical.

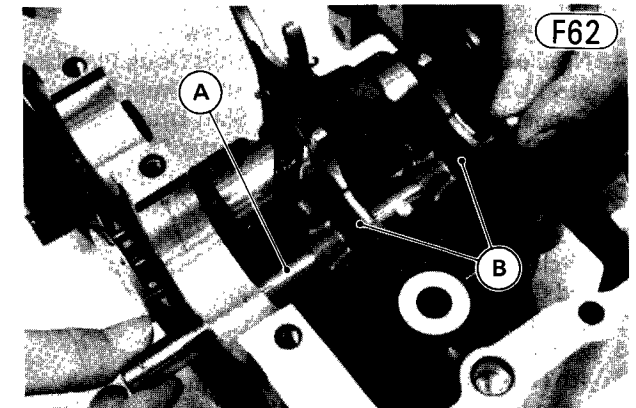

100 DISASSEMBLY—ENGINE REMOVED

Transmission

F63

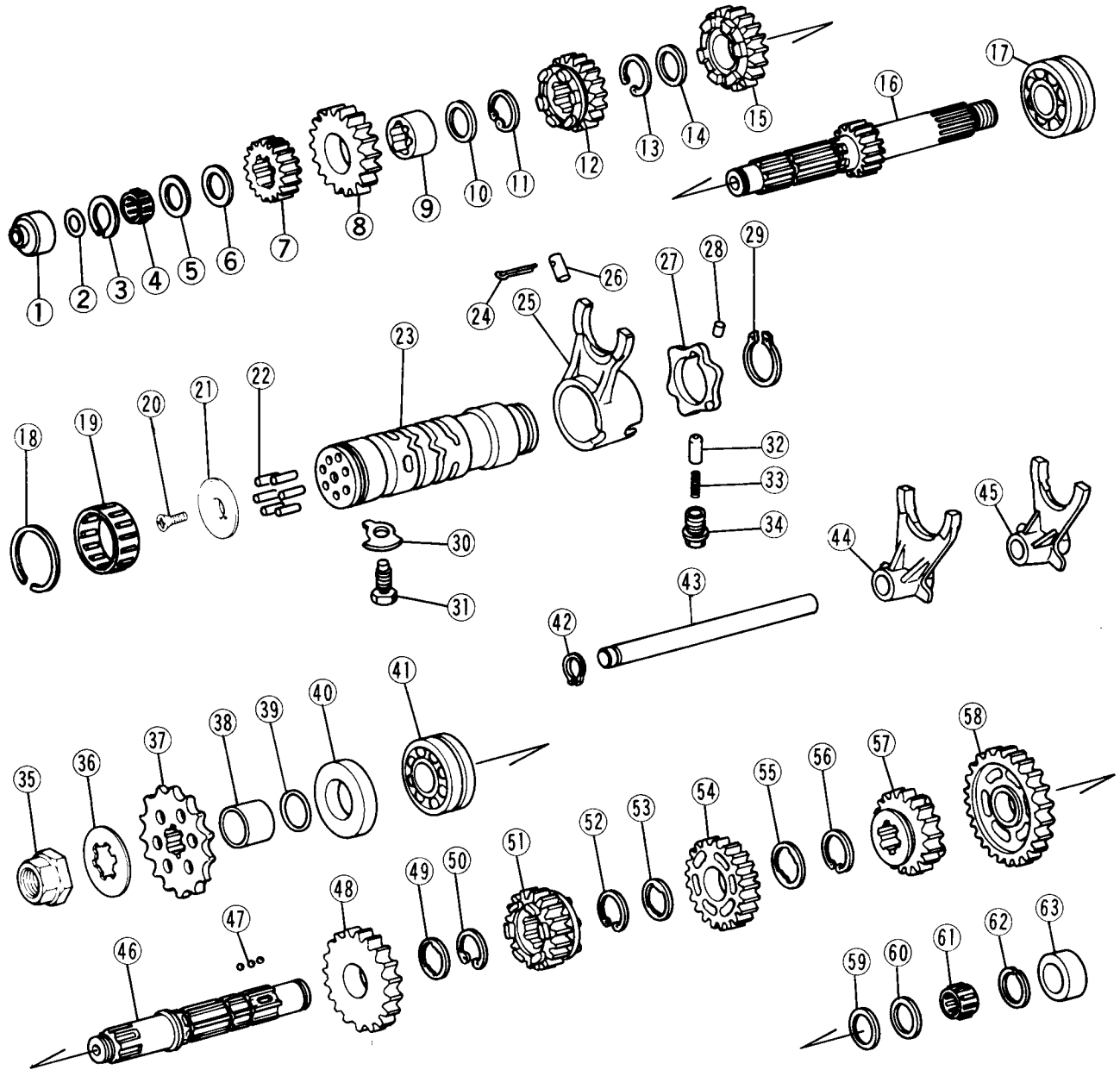

- | | | | |
|-----------------------|--------------------------|------------------------|------------------------|
| 1. Bearing Outer Race | 18. Circlip | 34. Positioning Bolt | 50. Circlip |
| 2. O Ring | 19. Needle Bearing | 35. Nut | 51. 5th Gear (O) |
| 3. Circlip | 20. Screw | 36. Splined Washer | 52. Circlip |
| 4. Needle Bearing | 21. Shift Drum Pin Plate | 37. Engine Sprocket | 53. Splined Washer |
| 5. Steel Washer | 22. Shift Drum Pin | 38. Collar | 54. 3rd Gear (O) |
| 6. Copper Washer | 23. Shift Drum | 39. O Ring | 55. Splined Washer |
| 7. 2nd Gear (D) | 24. Cotter Pin | 40. Oil Seal | 56. Circlip |
| 8. 5th Gear (D) | 25. 4th/5th Shift Fork | 41. Ball Bearing | 57. 4th Gear (O) |
| 9. Copper Bushing | 26. Guide Pin | 42. Clip | 58. 1st Gear (O) |
| 10. Washer | 27. Operating Plate | 43. Shift Rod | 59. Copper Washer |
| 11. Circlip | 28. Pin | 44. 2nd/3rd Shift Fork | 60. Steel Washer |
| 12. 3rd Gear (D) | 29. Circlip | 45. 1st Shift Fork | 61. Needle Bearing |
| 13. Circlip | 30. Lockwasher | 46. Output Shaft | 62. Circlip |
| 14. Washer | 31. Drum Guide Bolt | 47. Steel Ball | 63. Bearing Outer Race |
| 15. 4th Gear (D) | 32. Positioning Pin | 48. 2nd Gear (O) | |
| 16. Drive Shaft | | | |

**Shift Drum
Disassembly:**

- Drop out the operating plate pin (28).
- Remove the screw (20) and shift drum pin plate (21).
- Pull out the pins (22) (6).
- To remove the shift drum needle bearing (19), tap out the needle bearing using the shift drum bearing driver (special tool).

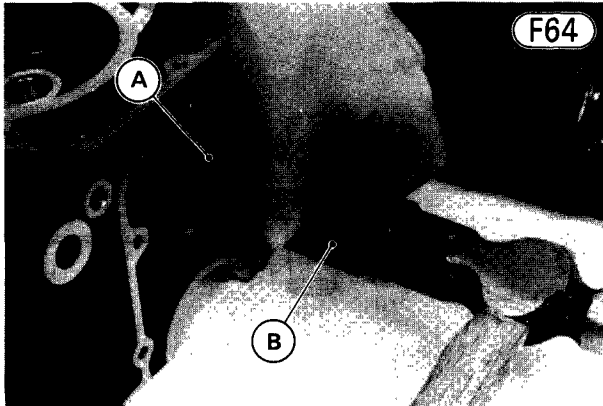

A. Needle Bearing B. Bearing Driver (57001-286)

**Drive Shaft
Disassembly:**

- Pull off the drive shaft sleeve and spacer.
- Remove the needle bearing outer race (1).
- Remove the circlip (3) and pull off the needle bearing (4), steel washer (5), and copper washer (6).
- Pull off 2nd gear (7), 5th gear (8), the copper bushing (9), and washer (10).

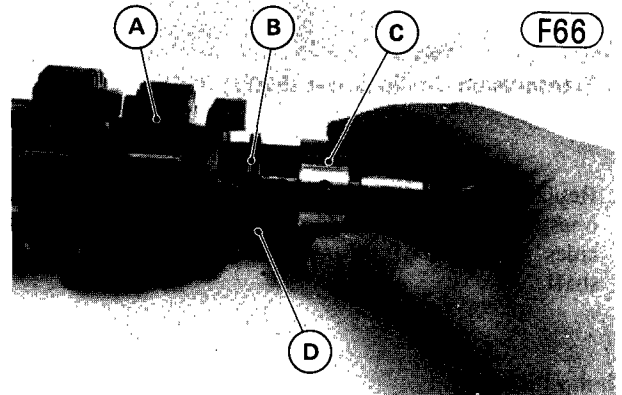

A. 3rd Gear B. Circlip C. Copper Bushing D. Washer

Assembly Notes:

1. The long shift drum pin must be in the position shown in Fig. F65. If the pin is assembled in the wrong position, the neutral indicator light will not light when the gears are in neutral.

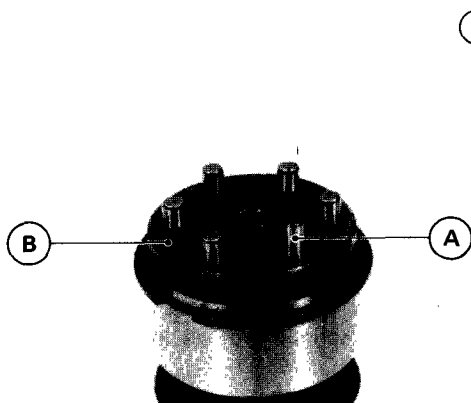

A. Long Shift Drum Pin B. Hole

2. Apply a non-permanent locking agent to the pin plate screw, and tighten it.
3. Install the shift drum needle bearing using a suitable driver. Press it so that the end of the bearing is even

- Remove the circlip (11), and pull off 3rd gear (12)
- Remove the circlip (13), and pull off the washer (14) and 4th gear (15).
- Remove the ball bearing (17) using the stem bearing puller and adapter (special tools).

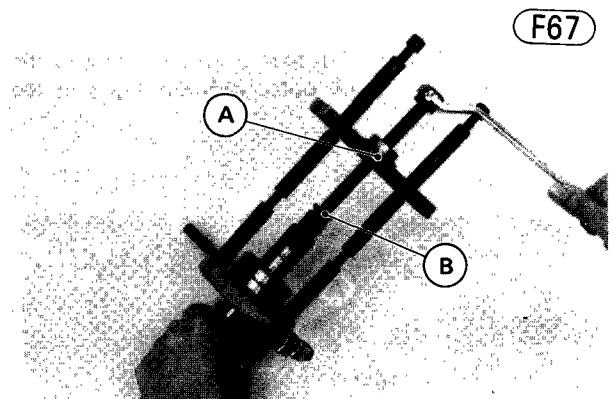

A. Bearing Puller (57001-135)
B. Adapter (57001-317)

Assembly Notes:

1. Install the drive shaft ball bearing using the trans

102 DISASSEMBLY—ENGINE REMOVED

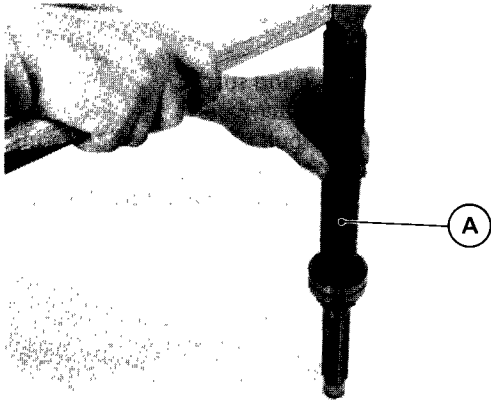

F68

A. Transmission Circlip Driver (57001-380)

2. Replace any circlips that were disassembled with new ones, and install the circlip so that the opening coincides with one of the splined grooves in the drive shaft.

Circlip Installation

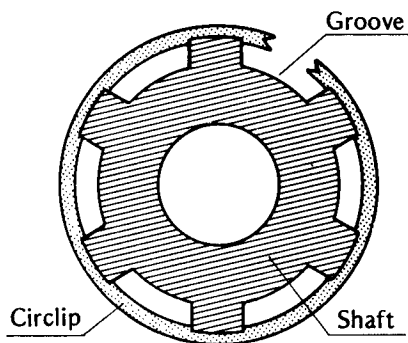

F69

3. When assembling the 5th gear copper bushing to the drive shaft, align its oil holes with the holes in the shaft.

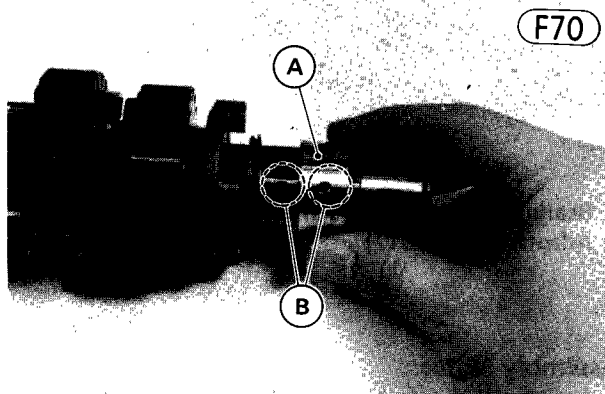

F70

4. Be sure that all parts are put back in the correct sequence and all circlips and flat washers are properly in place. Proper sequence starting with 1st gear (part of drive shaft) is 1st gear, 4th gear, washer, circlip, 3rd gear, circlip, washer, copper bushing, 5th gear, 2nd gear, copper washer, steel washer, needle bearing, circlip, needle bearing race.
5. The drive shaft gears can be recognized by size, the gear with the smallest diameter being 1st gear, and the largest one being 5th gear.

Drive Shaft Gears

F71

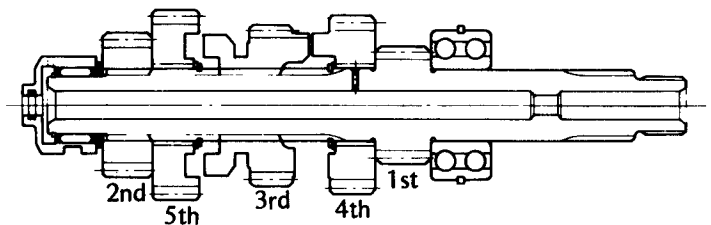

Output Shaft

Disassembly:

- Pull off the needle bearing outer race (63).
- Remove the circlip (62), and pull off the needle bearing (61), steel washer (60), and copper washer (59).
- Pull off 1st gear (58).
- 4th gear (57) has three steel balls (47) assembled into it for neutral positioning. To remove this gear with the balls, quickly spin the shift in a vertical position while holding 3rd gear, and pull off 4th gear upwards.
- Remove the circlip (56), and pull off the splined washer (55) and 3rd gear (54), and another splined washer (53).
- Remove the circlip (52), and pull off 5th gear (51).
- Remove the circlip (50), and pull off the splined washer (49) and 2nd gear (48).
- Remove the output shaft ball bearing (41) using the stem bearing puller (special tool).

Assembly Notes:

1. Install the output shaft ball bearing using the steering stem bearing driver (special tool).
2. Replace any circlips that were removed with new ones. Install the circlip so that its opening coincides with one of the splined grooves in the output shaft (Fig. F72).
3. Install the splined washer so that its teeth do not coincide with the circlip opening (Fig. F72).
4. Do not use grease on the three balls during assembly; these balls must be able to move freely.
5. Be sure that all parts are put back in the correct sequence and all circlips and splined washers are properly in place. Proper sequence starting with the engine sprocket side is 2nd gear, splined washer, circlip, 5th gear; circlip, splined washer, 3rd gear, splined washer, circlip, 4th gear, 1st gear, copper washer, steel washer,

DISASSEMBLY—ENGINE REMOVED 10:

6. The output shaft gear sizes are opposite from those of the drive shaft gears, the largest being 1st gear and the smallest, 5th gear.

Circlip, Splined Washer Installation

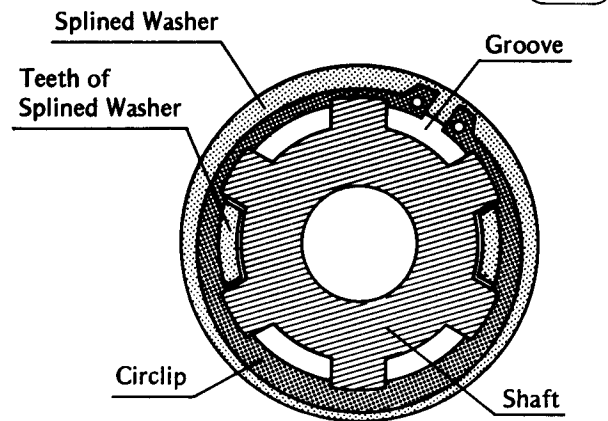

Output Shaft Gears

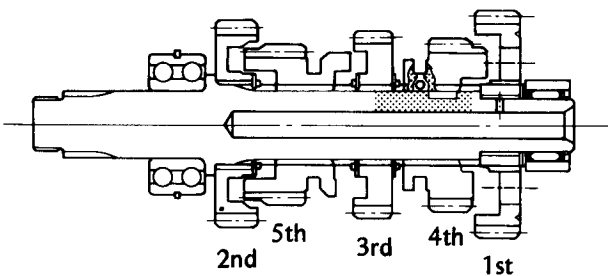

CRANKSHAFT (including connecting rods), CAMSHAFT CHAIN, AND PRIMARY CHAIN

Removal:

- Remove the engine (Pg. 86).
- Set the engine on a clean surface or, preferably, into a disassembly apparatus with some means of holding the engine steady while parts are being removed.
- Remove the camshafts as explained in camshaft removal (Pg. 53).
- Remove the cylinder head (Pg. 57).
- Remove the cylinder block (Pg. 60).
- Remove the pistons (Pg. 62).
- Split the crankcase (Pg. 89).
- Lift off the crankshaft with the camshaft chain and

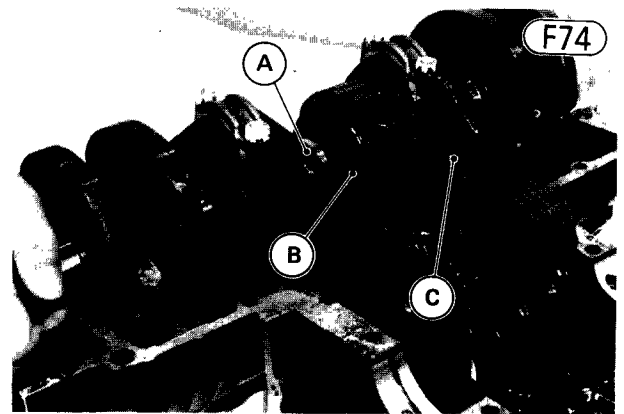

A. Crankshaft
B. Camshaft Chain
C. Primary Chain

- Pull the oil seals off both ends of the crankshaft.
- Remove the camshaft chain from the crankshaft.
- Remove the primary chain.

Installation Notes:

1. If a new crankshaft and/or connecting rod is used, select the proper bearing insert in accordance with the combination of connecting rod and the crankshaft marks (See Pg. 105).
2. If a new crankshaft, crankcase halves, and/or main bearing inserts are used, select the proper bearing insert in accordance with the combination of crankcase and the crankshaft marks. If the crankcase only is replaced with a new one, first measure the diameter of the crankshaft journal, mark its flywheel in accordance with the diameter (Pg. 175), and then select the right bearing inserts in accordance with Table F2.

Table F2 Main Bearing Insert Selection

Crankcase Marking \ Crankshaft Marking	○	No mark
	1	Brown P/N: 92028-1102
No mark	Black P/N: 92028-1101	Blue P/N: 92028-1100

Crankcase Marking (Upper Crankcase)

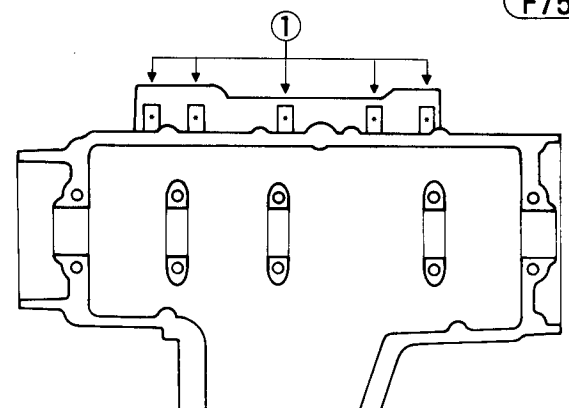

104 DISASSEMBLY—ENGINE REMOVED

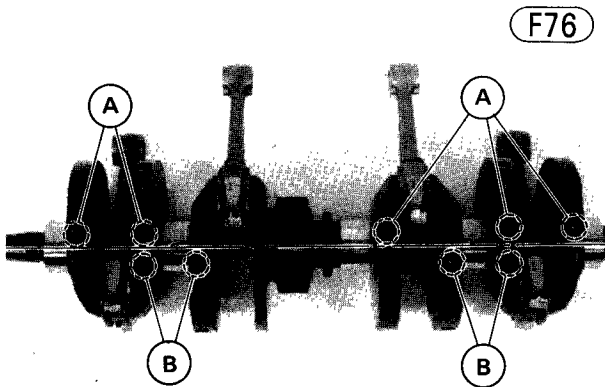

- A. Marking for Crankshaft Journal Diameter**
 ("1" or No mark)
- B. Marking for Connecting Rod Journal Diameter**

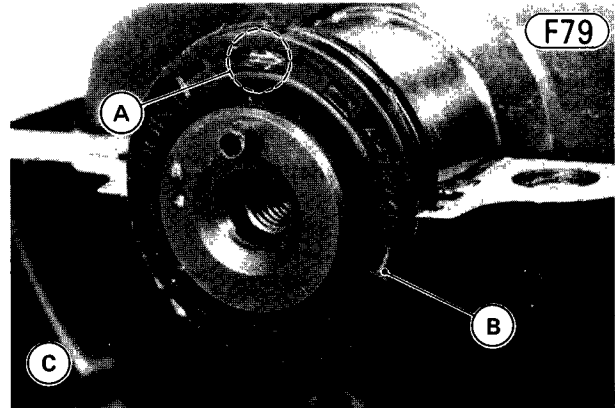

- A. Arrow Mark** **C. Contact Breaker Side (Right End)**
- B. Oil Seal**

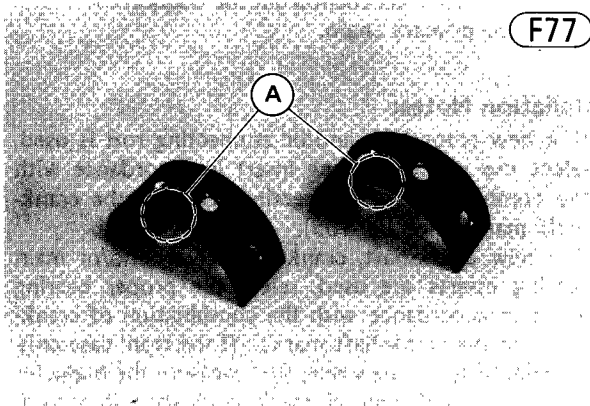

- A. Painted Marks (Brown, Black, or Blue)**

3. Apply engine oil to the main bearing inserts.
4. Apply a high temperature grease to the lip of the oil seals, and fit the oil seals onto both sides of the crankshaft with the arrow mark on the oil seal facing out. The arrow mark should show the same direction of the crankshaft rotation (clockwise, watching from the pick-up coil side).

CONNECTING RODS

Removal (each side):

- Remove the crankshaft (Pg. 103).
- Remove the nuts (2) and pull off the connecting rod big end cap.

CAUTION To prevent damage to the crankshaft journals, do not allow the big end cap bolts to bump against them.

- Remove the connecting rod bearing insert halves from the connecting rod big end and the big end cap.

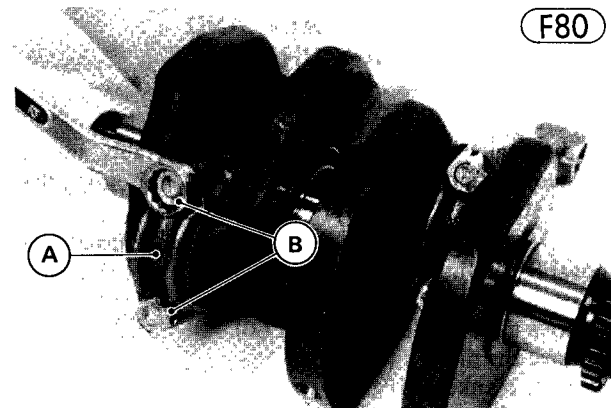
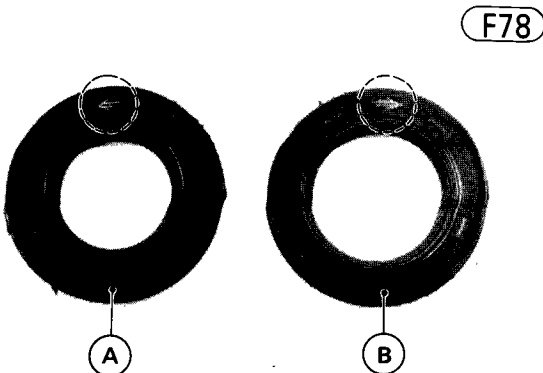

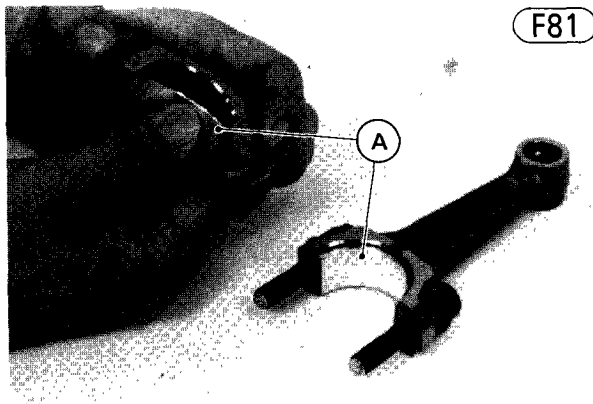

A. Bearing Inserts

Installation Notes:

1. Apply engine oil to the rod bearing inserts.
2. A pair of connecting rods (#1 and #2, or #3 and #4) should have the same weight mark in each pair. This weight mark, indicated using a capital letter, is stamped on the connecting rod big end.

Table F3 Connecting Rod Bearing Insert Selection

Con-Rod Marking \ Crankshaft Marking	○	No mark
○	Black P/N: 13034-051	Brown P/N: 13034-052
No mark	Green P/N: 13034-050	Black P/N: 13034-051

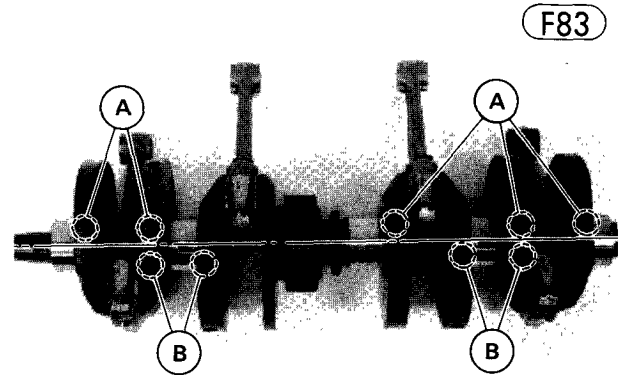

A. Marking for Crankshaft Journal Diameter
B. Marking for Connecting Rod Journal Diameter
 ("○" or No mark)

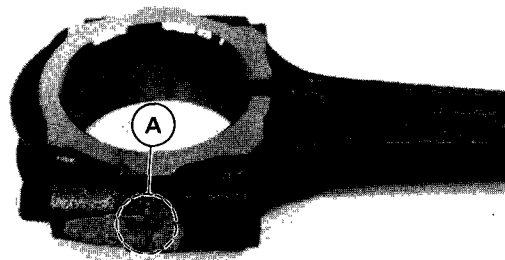

A. Weight Mark

3. The connecting rod big end cap is machined with the connecting rod as a set, so fit them together so that the weight marks align (Fig. F82). The big end cap must be replaced together with the connecting rod as a set.
4. If a new crankshaft and/or connecting rod is used, select the right rod bearing insert in accordance with the combination of the connecting rod and the crankshaft marks (Fig. F83). If the connecting rod only is replaced with a new one, first measure the diameter of the crankpin, mark its flywheel in accordance with the diameter (Pg. 173), and then select the

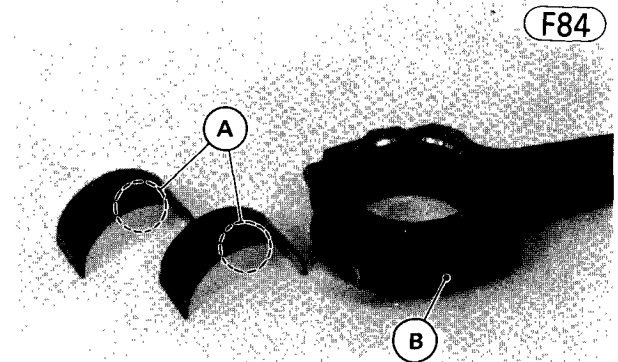

A. Painted Marks (Green, Black, or Brown)
B. Marking for Connecting Rod Inside Diameter
 ("○" or No mark)

5. Hand tighten both nuts first, and then tighten each nut to 3.7 kg-m (27 ft-lbs) of torque.

Disassembly—Chassis

Table of Contents

FLOW CHART	108
WHEELS, BRAKES	
WHEELS	109
Front Wheel	109
Rear Wheel	110
Speedometer Gear Housing	111
Rear Wheel Coupling, Rear Sprocket	114
Wheel Bearings, Brake Discs	115
Tires	116
DISC BRAKES	118
Pads	118
Caliper	119
Master Cylinder	122
Reservoir	126
Brake Hose	126
CABLES	
CLUTCH CABLE	127
THROTTLE CABLE	127
SPEEDOMETER CABLE	128
TACHOMETER CABLE	128
LIGHTS, METERS	
HEADLIGHT UNIT	129
TURN SIGNAL LIGHTS (TURN SIGNAL/RUNNING POSITION LIGHTS)	130
TURN SIGNAL ASSEMBLYS	130
TAIL/BRAKE LIGHT(S)	132
INDICATOR LIGHTS	132
SPEEDOMETER, TACHOMETER, METER LIGHTS	133
VOLTMETER, METER LIGHT, INDICATOR LIGHTS (on KZ750-E)	134
SWITCHES	
IGNITION SWITCH	134
FRONT BRAKE LIGHT SWITCH	135
REAR BRAKE LIGHT SWITCH	135
STARTER LOCKOUT SWITCH	136
STEERING	
HANDLEBAR	136
STEERING STEM	138
STEERING STEM BEARINGS	139
SUSPENSIONS, DRIVE CHAIN	
FRONT FORK	140
REAR SHOCK ABSORBERS	143
SWING ARM	143

The following chart is intended to be aids to proper removal. Select the component you wish to remove and follow the arrows to that point on the chart.

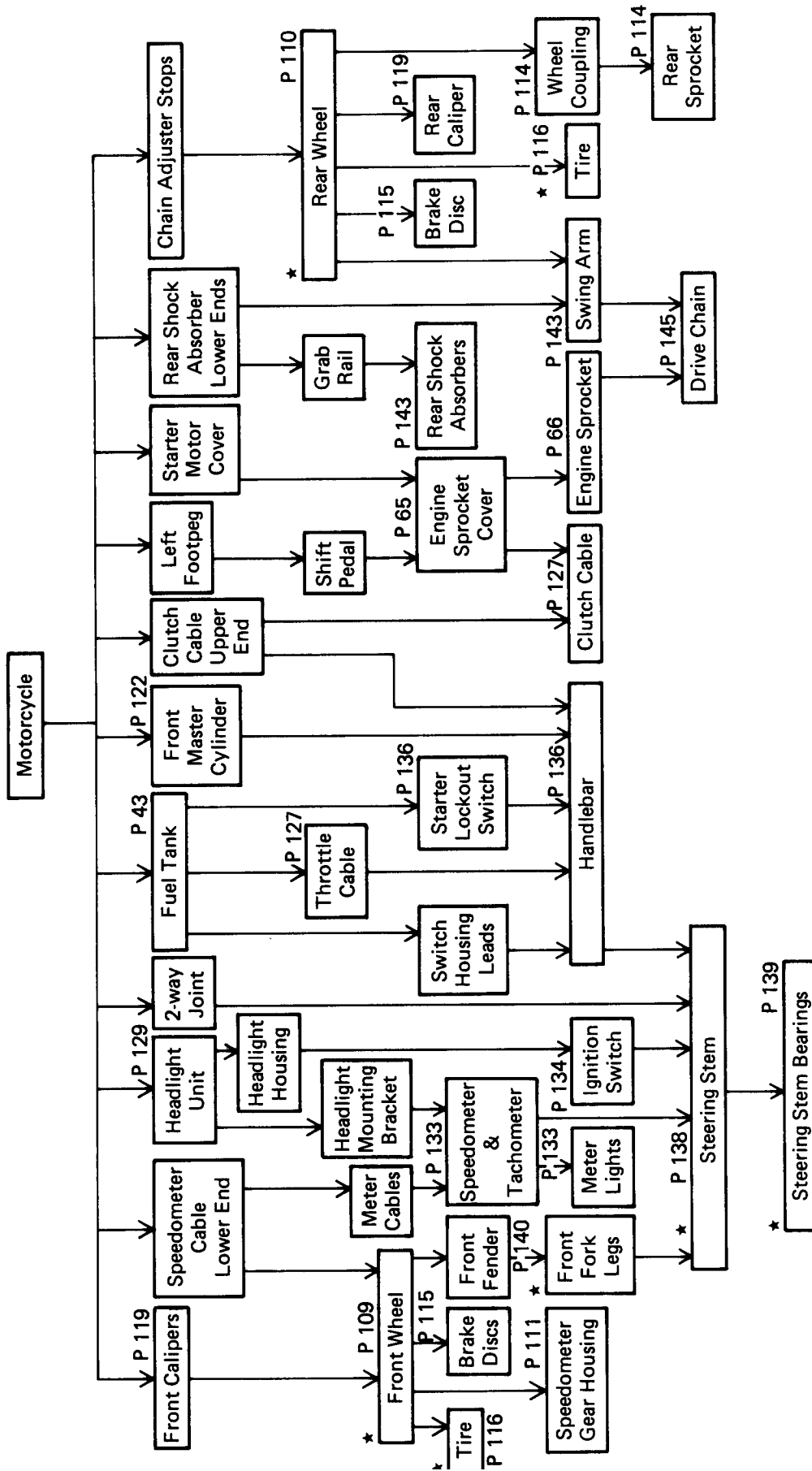

NOTE: Action with a mark (*) requires special tool(s) for removal, installation, disassembly, or assembly.

WHEELS

Removal, installation, disassembly, and assembly of the wheel is divided as follows:

Front Wheel Removal and Installation

Rear Wheel Removal and Installation

Speedometer Gear Housing Disassembly and Assembly Notes

Rear Wheel Coupling, Rear Sprocket Removal and Installation Notes

Wheel Bearings, Brake Discs Removal and Installation Notes

Tires Removal and Installation

Front Wheel Removal:

NOTE: For KZ750-H, refer to this removal section, noting the following:

○To remove the wheel, remove the axle nut, and loosen the axle clamp bolt nut. Holding the wheel to facilitate the wheel removal, pull the axle, and then remove the wheel from the motorcycle.

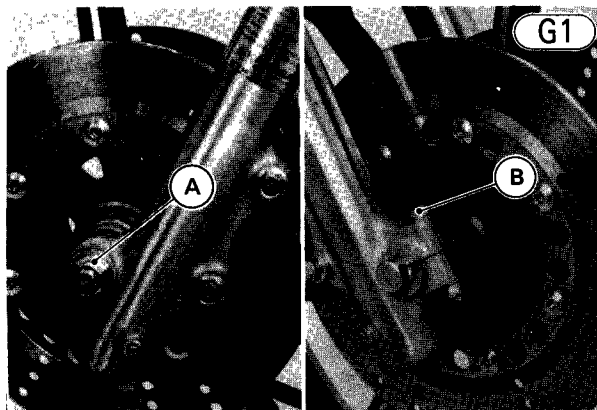

A. Axle Nut

B. Axle Clamp Bolt

●Disconnect the lower end of the speedometer cable with pliers.

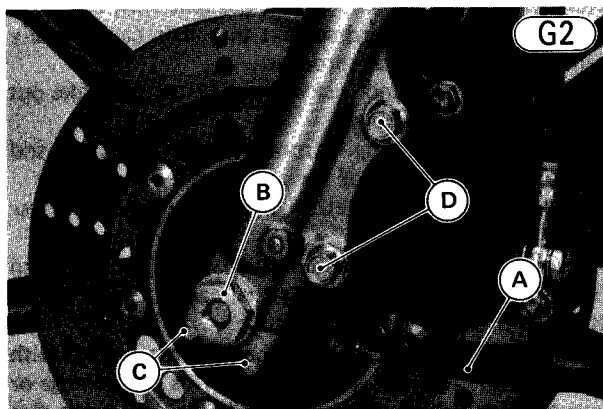

A. Speedometer Cable

B. Axle Nut

D. Caliper Mounting Bolts

- Unbolt one of the brake calipers, and move it free of the fork leg. Avoid straining the brake lines and fittings.
- Insert a wood wedge (4~5 mm thick) between the disc brake pads. This prevents the pads from being moved out of their proper position, should the brake lever be squeezed accidentally.
- Loosen the axle clamp nuts (4) but do not remove them. Then loosen the axle nuts (2).
- Remove the axle clamp nuts (4), lockwashers (4), and clamps (2).
- Use a jack under the engine or other suitable means to lift the front of the motorcycle. Drop the front wheel out of the forks, and remove it.

CAUTION Do not lay the wheel down on one of the discs. This can damage or warp the disc. Place the blocks under the wheel so that the discs do not touch the ground.

Front Wheel Installation:

NOTE: For KZ750-H, refer to this installation section, noting the following:

1. To install the wheel, holding the wheel in its place between the front fork legs, insert the axle front the right, and install the axle nut finger-tight.
 2. Tighten the axle nut to 8.0 kg-m (58 ft-lbs) of torque, and tighten the axle clamp bolt nut to 2.0 kg-m (14.5 ft-lbs) of torque.
- Check that the speedometer gear housing is properly fitted on the front hub (See the speedometer gear housing assembly notes on Pg. 114), and check that the collar is on the right side of the hub.
 - Center the axle so that the gap between the axle nut surface and the end of the axle is the same on each side.
 - Position the front wheel in its place between the front fork tubes, and slowly lower the front fork tube bottom ends onto the front axle.
 - Mount the front axle clamps, and tighten the nuts loosely with the lockwashers. The arrow at the bottom of the clamp must point to the front (Fig. G4).
 - Turn the speedometer gear housing so that it points to the rear, and fit the housing stop to the fork leg stop.

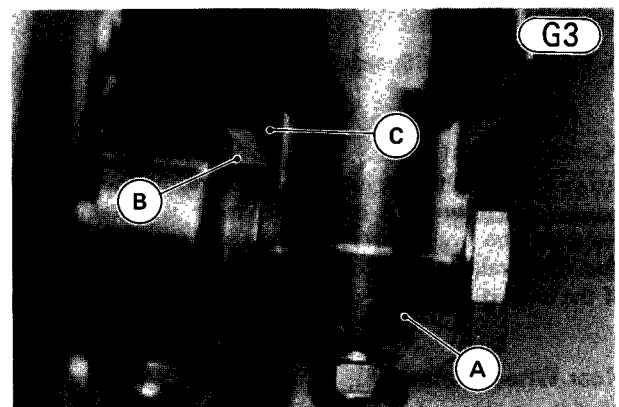

A. Front Axle Clamp

C. Fork Leg Stop

110 DISASSEMBLY—CHASSIS

- Tighten the axle nuts to 8.0 kg-m (58 ft-lbs) of torque.
- Tighten first the front axle clamp nut and then the rear nut to 1.8 kg-m (13.0 ft-lbs) of torque. There will be a gap at the rear of the clamp after tightening.

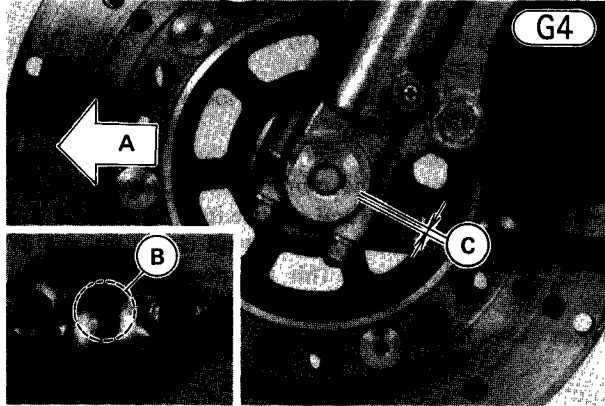

A. Front B. Arrow Mark C. Gap

- Install the brake caliper, and tighten the caliper mounting bolts (2) to 4.0 kg-m (29 ft-lbs) of torque.
- Run the speedometer cable through the cable guide at the front fender.
- Insert the speedometer inner cable into the housing while turning the wheel so that the slot in the end of the cable will seat on the tongue of the speedometer pinion. Tighten the cable nut with pliers.

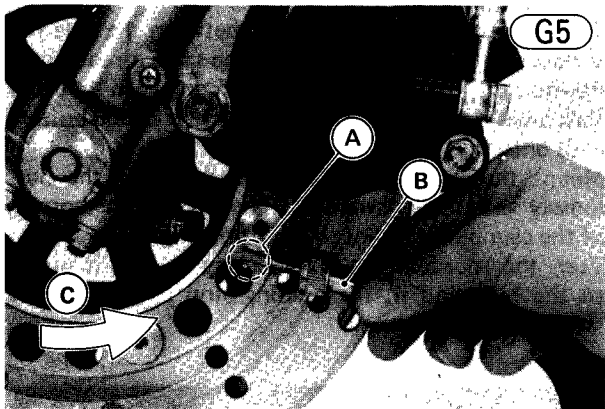

A. Slot B. Speedometer Cable C. Turn.

- Check the front brake.

WARNING Do not attempt to drive the motorcycle until a full brake lever is obtained by pumping the brake lever until the pads are against the disc. The brakes will not function on the first application of the lever if this is not done.

Rear Wheel Removal:

- Put the motorcycle up on its center stand.
- Loosen the self-locking nut at the rear end of the

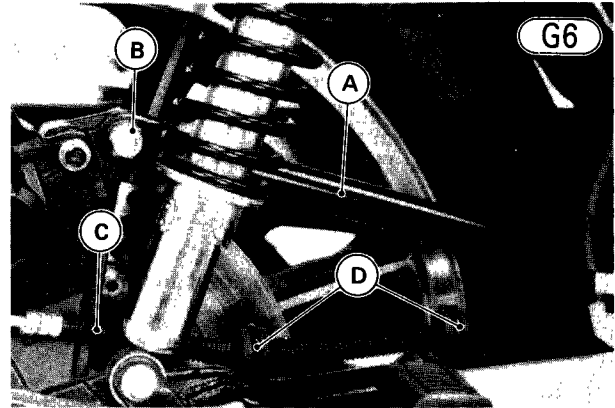

A. Torque Link C. Brake Hose
B. Nut D. Guides

- Free the brake hose from its guides.
- Loosen the left and right chain adjuster locknuts, and fully loosen both chain adjuster bolts.

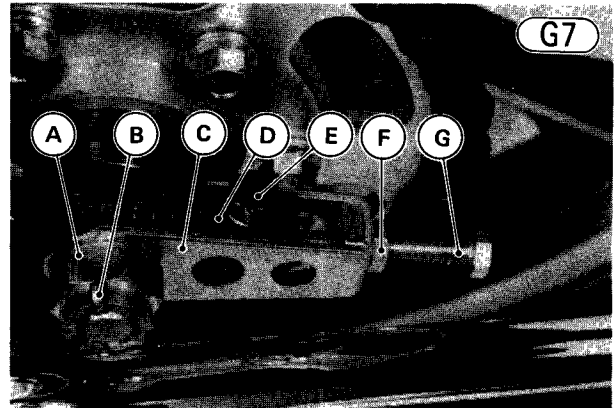

A. Axle Nut E. Stop Bolt
B. Cotter Pin F. Locknut
C. Chain Adjuster G. Adjusting Bolt
D. Chain Adjuster Stop

- Remove the cotter pin, loosen the axle nut, and then push the wheel forward so that the chain can be easily removed from the rear sprocket.
- Remove the bolts and lockwashers (2 ea) and take out the chain adjuster stops.
- Remove the drive chain from the rear sprocket, and hang it to the left side of the swing arm.
- Pull the rear wheel together with the rear caliper toward the rear.
- Remove the axle nut and left chain adjuster. Then pull off the axle with the right chain adjuster.
- Remove the rear wheel.

CAUTION Do not lay the wheel on the ground with the disc facing down. This can damage or warp the disc. Place blocks under the wheel so the disc does not touch the ground.

- Run the axle through the swing arm and the caliper

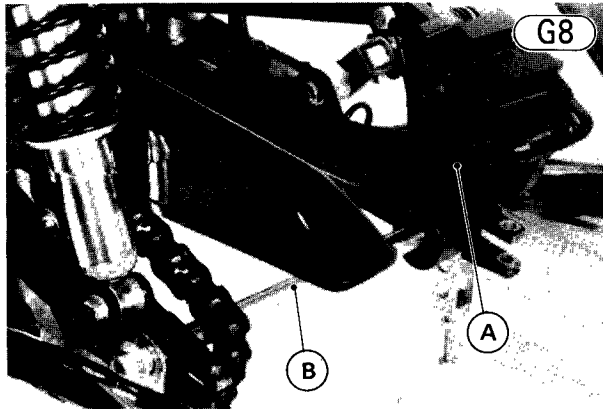

A. Rear Caliper B. Axle

- Insert a wood wedge (7~8 mm thick) between the disc brake pads. This prevents them from being moved out of their proper position, should the brake pedal be pushed accidentally.

Rear Wheel Installation:

- Wipe out old grease and apply a little grease to the O ring on the rear hub (Fig. G23).
- Remove the wedge from between the brake pads, and pull the rear axle off the caliper holder and the swing arm.
- Slip back the rear wheel. Be sure the coupling sleeve is in place.
- Put the caliper on the disc so that the disc is between the pads, and run the axle through the right chain adjuster (facing the alignment mark side to the right), caliper, collar, rear hub, coupling sleeve, coupling, coupling collar, and left chain adjuster (facing the alignment mark to the left). Then screw on the axle nut.

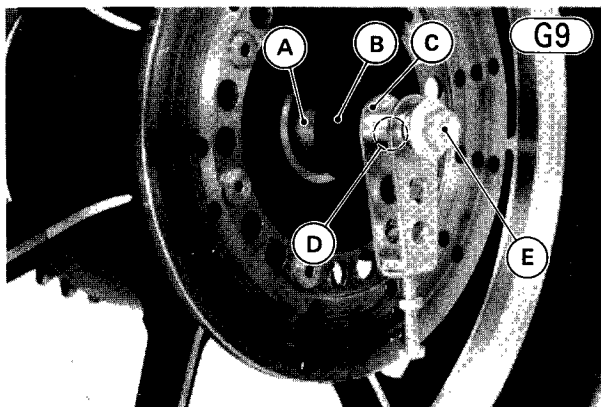

A. Collar B. Caliper C. Chain Adjuster D. Alignment Mark E. Rear Axle

- Put the rear wheel into the swing arm end, and install the chain adjuster stops (2). Tighten the bolts (2) with

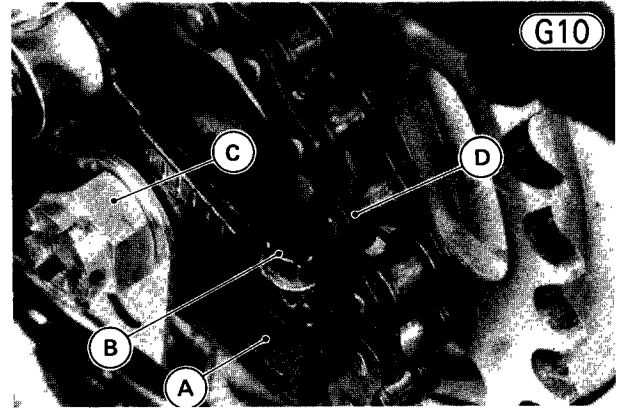

A. Chain Adjuster Stop B. Stop Bolt C. Axle Nut D. Drive Chain

- Fit the drive chain onto the rear sprocket.
- Adjust the drive chain (Pg. 23).
- If the caliper was removed, check the fluid level in the master cylinder, and bleed the brake line (Pg. 206).
- Check the rear brake.

WARNING Do not attempt to drive the motorcycle until a full brake pedal is obtained by pumping the brake pedal until the pads are against the disc. The brake will not function on the first application of the pedal if this is not done.

Speedometer Gear Housing Disassembly:

- Pull the speedometer gear housing (17) and collar (4) off the front wheel (10).
- Pull out the grease seal (15) using a hook.

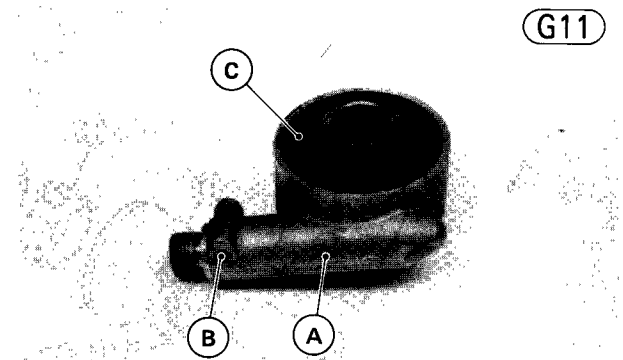

A. Speedometer Gear Housing B. Pin C. Grease Seal

- Pull out the speedometer gear (16).
- If the speedometer cable bushing (22) or speedometer pinion (21) needs to be removed, first drill the housing through the pin (19) using a 1 mm drill bit. Drill the housing from the gear side using a 2 mm drill bit. Using a suitable tool, tap out the pin, and then pull out the speedometer cable bushing, pinion, and washers (20).

NOTE: It is recommended that the assembly be re-

112 DISASSEMBLY-CHASSIS

Front Wheel

G12

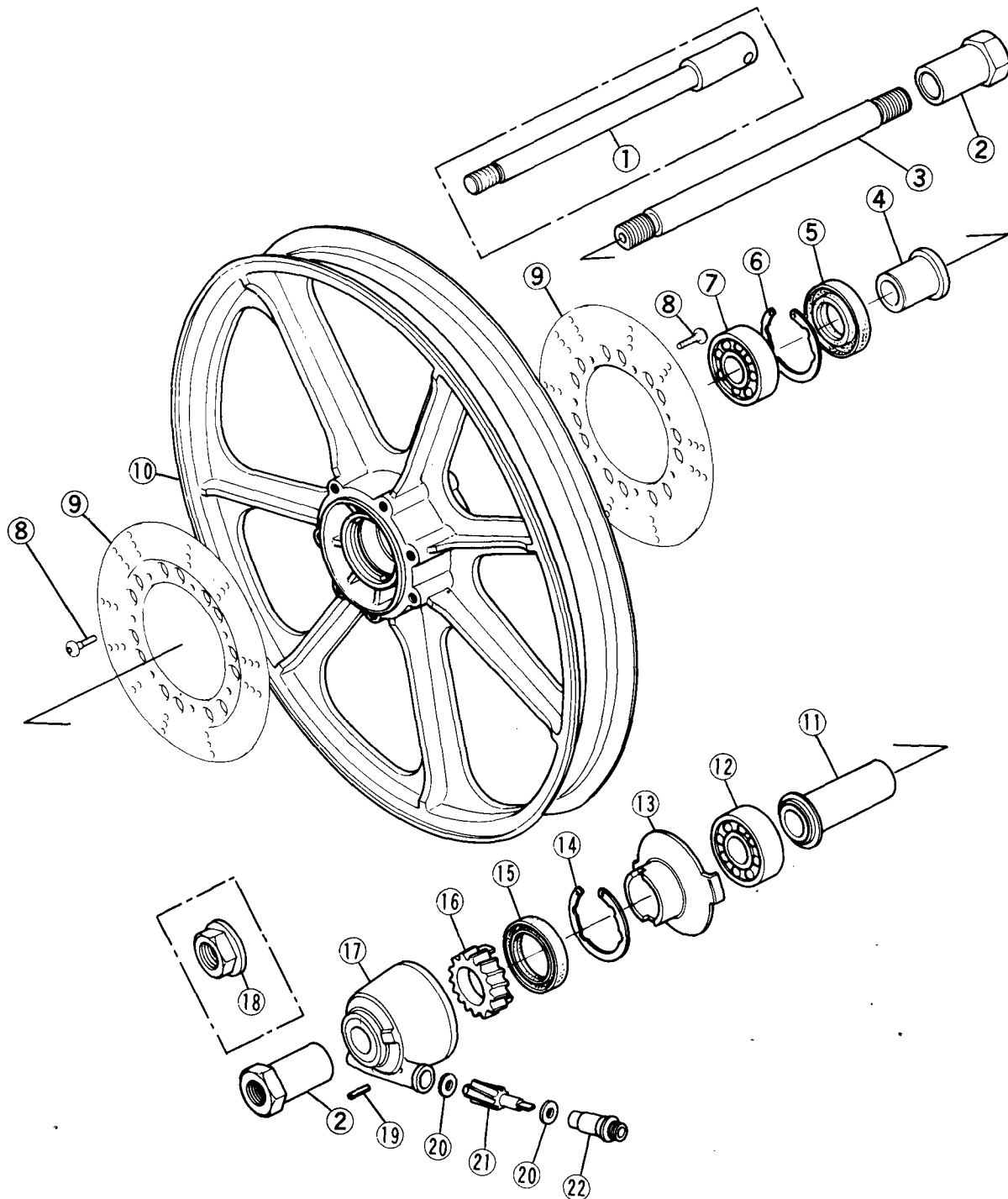

* : KZ750-H only

- *1. Front Axle
- 2. Axle Nut
- 3. Front Axle
- 4. Collar
- 5. Grease Seal
- 6. Circlip

- 8. Allen Bolt
- 9. Brake Disc
- 10. Front Wheel
- 11. Distance Collar
- 12. Ball Bearing
- 13. Speedometer Gear Drive
- 14. Circlip

- 16. Speedometer Gear
- 17. Speedometer Gear Housing
- *18. Axle Nut
- 19. Pin
- 20. Washer
- 21. Pinion
- 22. Rushing

Rear Wheel

G13

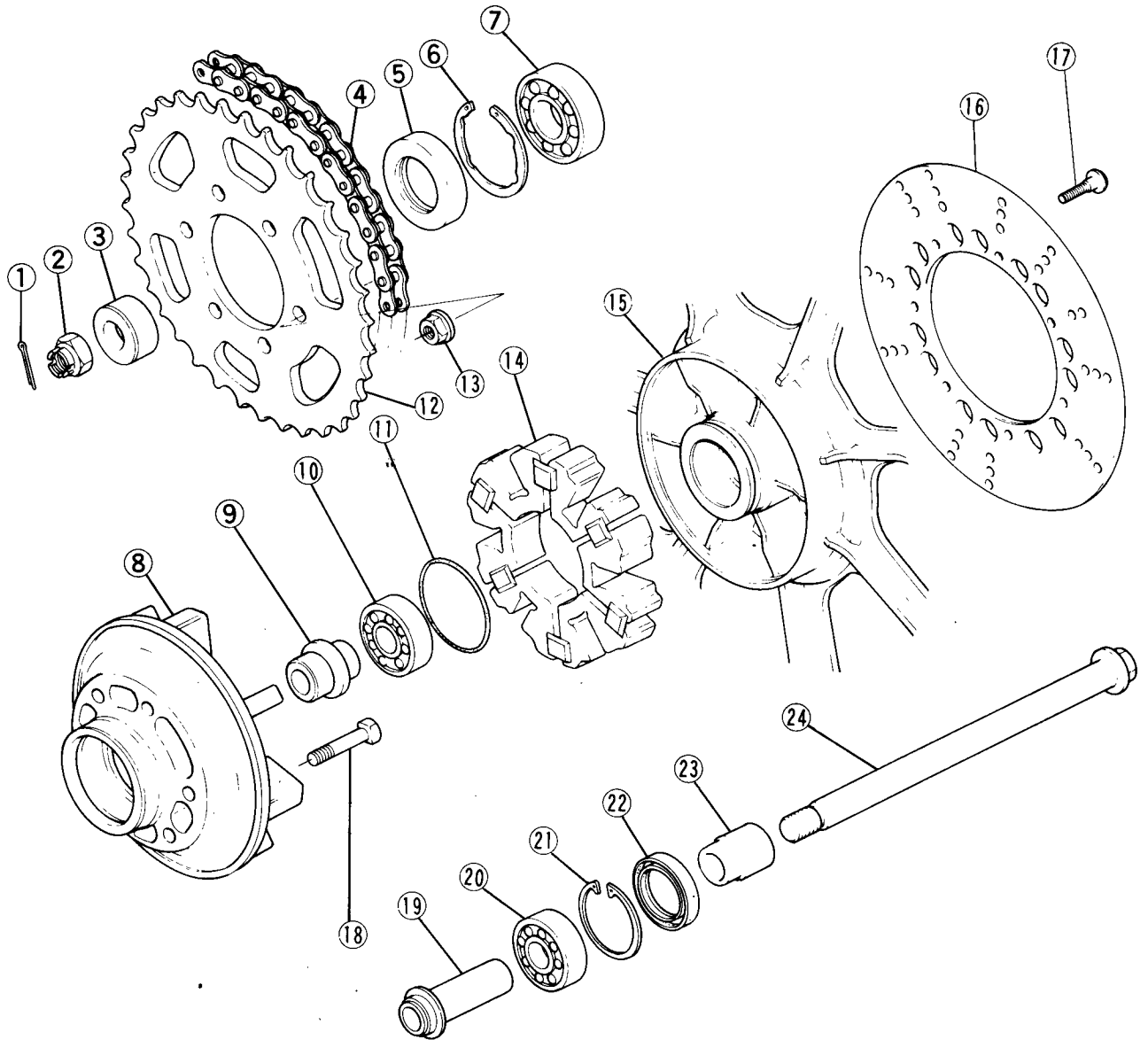

- 1. Cotter Pin
- 2. Axle Nut
- 3. Coupling Collar
- 4. Drive Chain
- 5. Grease Seal
- 6. Circlip
- 7. Ball Bearing
- 8. Wheel Coupling

- 9. Coupling Sleeve
- 10. Ball Bearing
- 11. O Ring
- 12. Rear Sprocket
- 13. Nut
- 14. Rubber Damper
- 15. Rear Wheel

- 17. Allen Bolt
- 18. Mounting Bolt
- 19. Distance Collar
- 20. Ball Bearing
- 21. Circlip
- 22. Grease Seal
- 23. Collar

114 DISASSEMBLY—CHASSIS

Speedometer Gear Housing Assembly Notes:

1. After inserting a new pin, stake the housing hole to secure the pin in place.

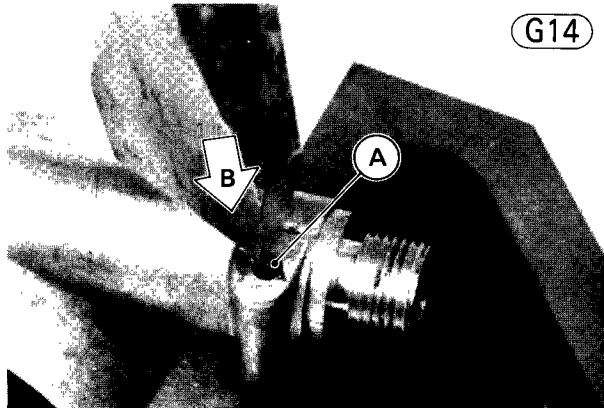

A. Pin B. Stake.

2. Replace the grease seal with a new one. Apply a little grease to the seal. Install it using a press or a suitable driver so that the face of the seal is level with the surface of the housing.
3. Regrease the speedometer gear.
4. Install the speedometer gear housing so that it fits in the speedometer gear drive notches.

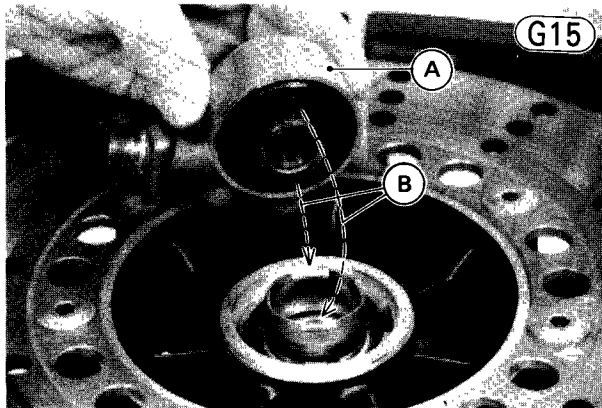

A. Speedometer Gear Housing
B. Fit in the gear drive notches.

Rear Wheel Coupling, Rear Sprocket Removal:

- Pull out the coupling collar ③ from the left, and the coupling sleeve ⑨ from the right.
- Install the rubber damper and wheel coupling temporarily on the rear hub to aid in rear sprocket removal.
- Remove the rear sprocket nuts ⑬ (6) to separate the rear sprocket ⑫ and wheel coupling ⑧.
- Remove the rear sprocket and remove the coupling from the rear wheel.
- Using a hook, pull out the grease seal ⑤ and remove

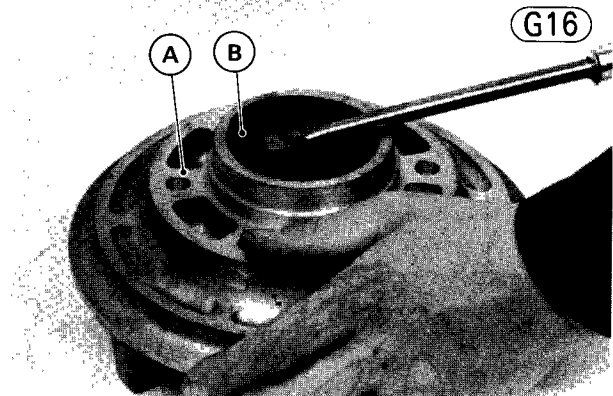

A. Wheel Coupling B. Grease Seal

- Using the bearing driver and driver holder (special tools) or some other suitable tool, remove the bearing ⑦ by tapping from the wheel side.

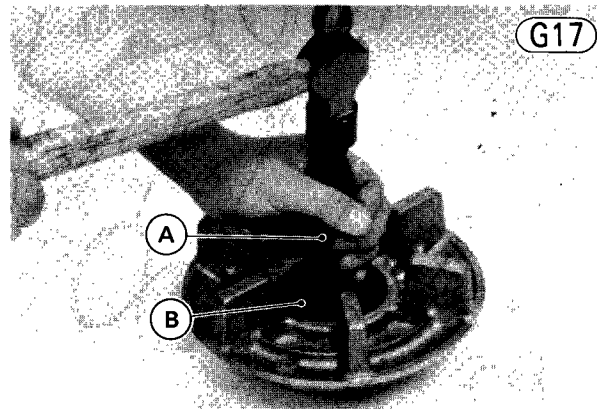

A. Bearing Driver Holder (57001-139)
B. Bearing Driver (57001-289)

Rear Wheel Coupling, Rear Sprocket Installation Notes:

1. Inspect the bearing, and replace if necessary (Pg. 197). Lubricate it, and then install it using the wheel bearing driver and the bearing driver holder (special tools).

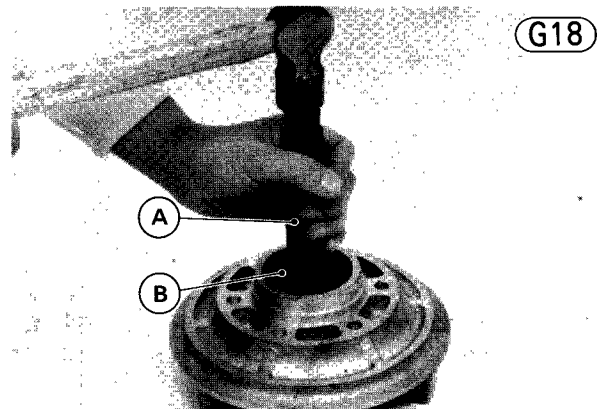

A. Bearing Driver Holder (57001-139)

2. Replace the grease seal with a new one using the suitable driver. Press the seal in until the face of the seal is level with the end of the grease seal hole. Apply a little grease to the grease seal lip.
3. Install the rear sprocket with the numbered side facing out. Tighten the sprocket nuts to 4.0 kg-m (29 ft-lbs) of torque.

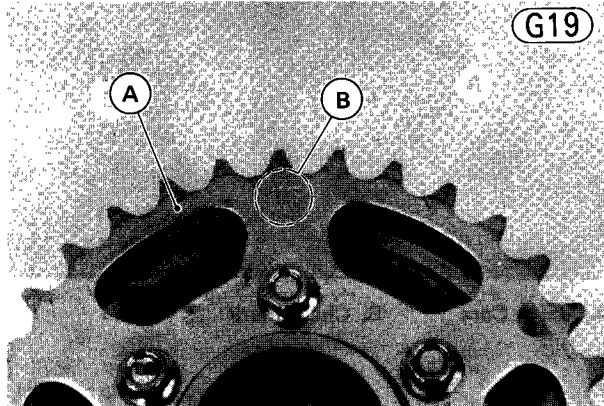

A. Rear Sprocket B. Tooth Number

Wheel Bearings, Brake Discs Removal:

CAUTION Do not lay the wheel on the ground with the disc facing down. This can damage or warp the disc. Place blocks under the wheel so the disc does not touch the ground.

- Remove the speedometer gear housing, rear wheel coupling, and/or collar(s) from the wheel.
- For the front wheel, remove the circlip ⑭ and speedometer gear drive ⑭.
- Remove the disc mounting Allen bolts ⑧ or ⑰, and take off the disc(s) ⑨ or ⑱.
- Remove the grease seal ⑤ or ⑳ using a hook, and remove the circlip ⑥ or ㉑.

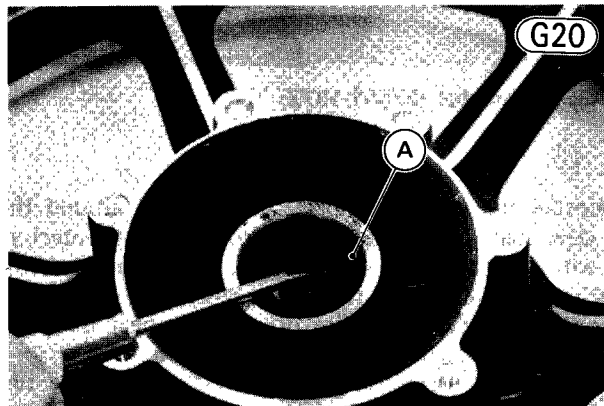

Bearing Removal

G21

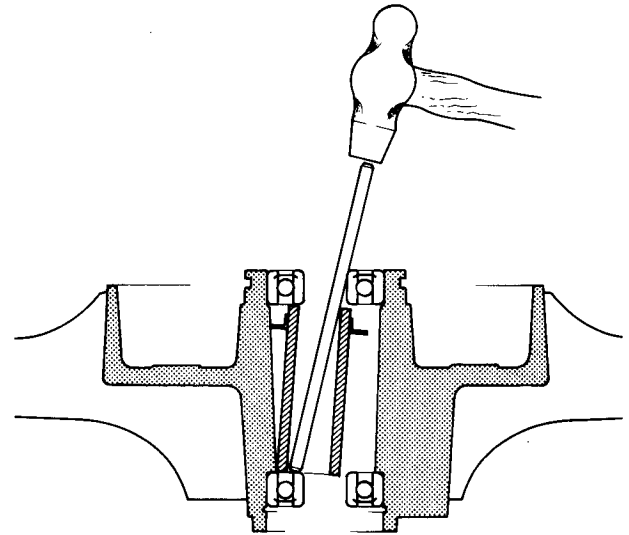

- Insert a metal rod into the hub from the left side, and remove the right side bearing ⑦ or ⑳ by tapping evenly around the bearing inner race.
- Remove the remaining bearing ⑫ or ⑩ by tapping evenly around the bearing inner race. The distance collar ⑪ or ⑲ come out with the bearing.

Wheel Bearings, Brake Discs Installation Notes:

1. Before installing the wheel bearings, blow any dirt or foreign particles out of the hub with compressed air to prevent contamination of the bearings.
2. Inspect the bearings and replace them if necessary (Pg. 197). Lubricate them and install them using the bearing driver and the bearing driver holder (special tools) so that the marked sides (shield sides for front hub bearings) face out.

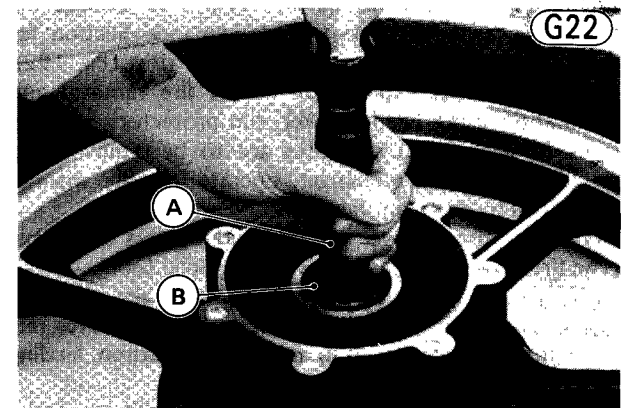

A. Bearing Driver Holder (57001-139)
B. Bearing Driver (57001-288) for Front Wheel, or

116 DISASSEMBLY—CHASSIS

- Inspect the grease seal and replace if necessary (Pg. 196). Press it in until it stops at the circlip in the hole using the same special tools used for bearing installation.
- Inspect the O ring ① on the rear hub replace it with a new one if it has deteriorated, and apply a little grease to the O ring.

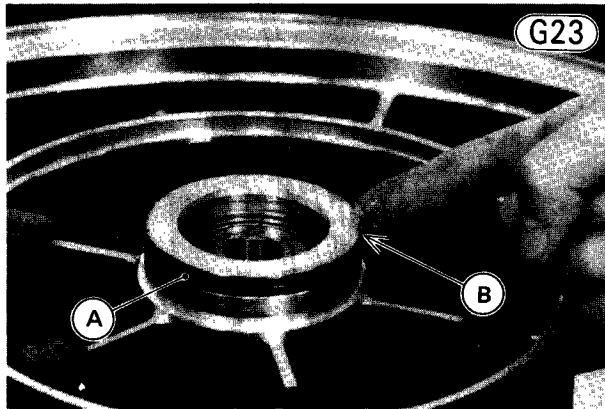

A. "O" Ring B. Grease.

- Tighten the disc mounting Allen bolts to 2.3 kg-m (16.5 ft-lbs) of torque. The disc must be installed with the chamfered hole side facing toward the wheel.
- After installing the disc, check the disc runout (Pg. 205).
- Completely clean off any grease that has gotten on either side of the disc with a high flash-point solvent. Do not use one which will leave an oily residue.

Tires Removal:

Damage to the rim flanges and tire beads spoil the airtightness of tubeless tires and rims. When handling tubeless tires and rims, be careful not to damage the air-sealing surfaces. See the Maintenance Section for detailed information regarding tubeless tires (Pg. 192).

The following explanation covers tire removal and installation using bead breaker, rim protectors, and tire irons (special tools). If tires are to be removed and installed using a tire changer, operate it in the manner prescribed by the manufacturer.

NOTE: A tire changer suitable for tubeless and tube-type tires is available as a Kawasaki special tool.

WARNING 1. To ensure safe handling and stability, use only wheels, valves, and tires recommended may result in an unsafe condition, leading to accident and injury.

2. Never install a tube on the rims on this motorcycle. They are designed for tubeless tires only.

•Remove the collar(s) or speedometer gear housing, and remove the disc(s) from the hub.

- To maintain wheel balance, mark the valve stem position on the tire with chalk so that the tire will be reinstalled in the same position.
- Take out the valve core to let out the air.

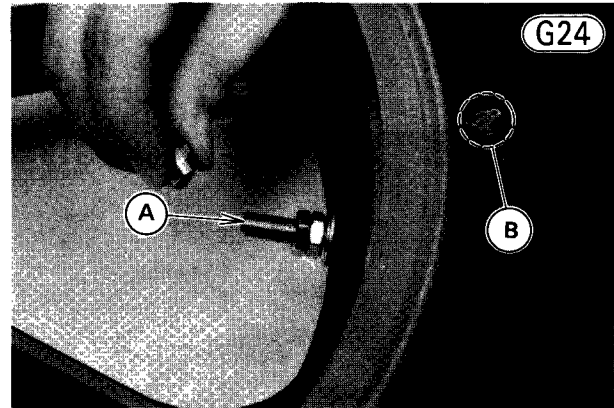

A. Valve Core B. Chalk Mark

- Lubricate the tire beads and rim flanges on both sides with a soap and water solution or rubber lubricant. This helps the tire beads slip off the rim flanges.

CAUTION Never lubricate with mineral oil (engine oil) or gasoline because they will cause deterioration of the tire.

- Break the beads away from both sides of the rim with the bead breaker (special tool).

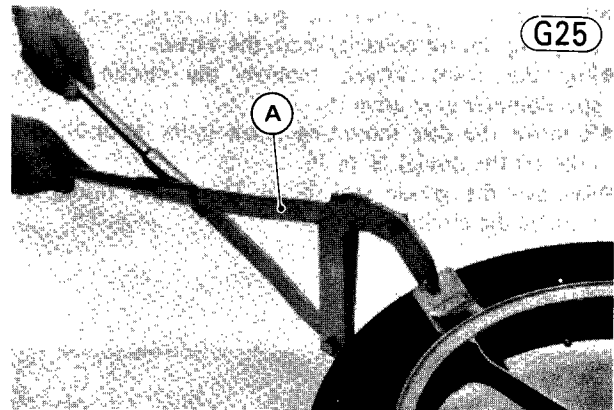

A. Bead Breaker (57001-1072)

- Install the rim protectors (special tools) around the valve stem. Lubricate the tire irons and rim protectors with a soap and water solution, or rubber lubricant.
- Step on the side of the tire opposite the valve stem, and start prying the tire off the rim near the valve stem with tire irons (special tools).

NOTE: For easier removal, always position the tire bead opposite the valve stem in the rim well, and pry

DISASSEMBLY—CHASSIS 1

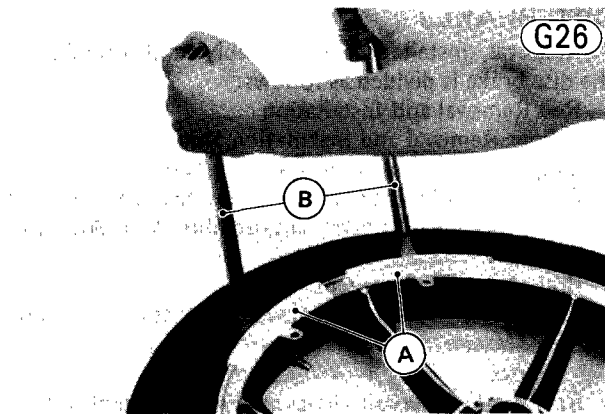

- A. Rim Protectors (57001-1063)
B. Tire Irons (57001-1073)

CAUTION Be careful not to scratch the inner liner and air sealing surfaces of the rim and tire with the tire irons. A scratched inner liner or sealing surface may allow air to leak.

Air Sealing Surfaces

G27

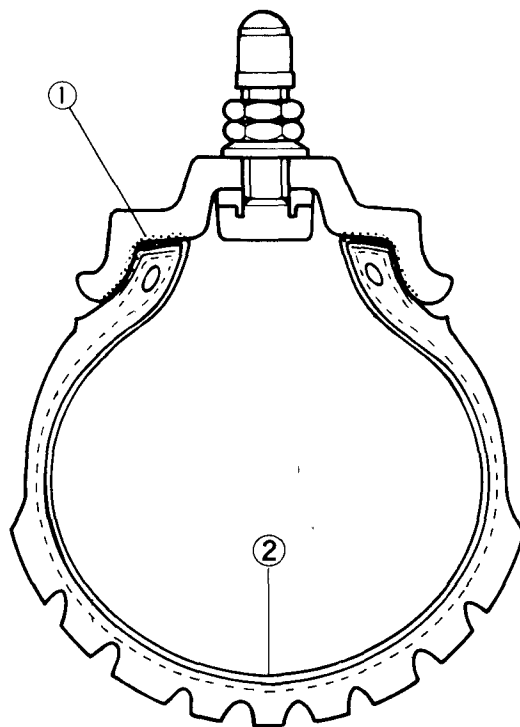

1. Air Sealing Surfaces
2. Inner Liner

- After removing the bead on one side, turn the wheel over and remove the other side.
- Remove the rim from the tire

Tire Installation:

- Inspect the rim and tire, and replace them if necessary (Pgs. 192, 195).

NOTE: Refer to Pg. 193 for tire repair.

- Clean the sealing surfaces of the rim and tire, and smooth the sealing surfaces of the rim with a fine emery cloth if necessary.
- Replace the valve with a new one. Tighten the mounting nut and locknut to 0.15 kg-m (13 in-lbs) of torque

Air Valve

G28

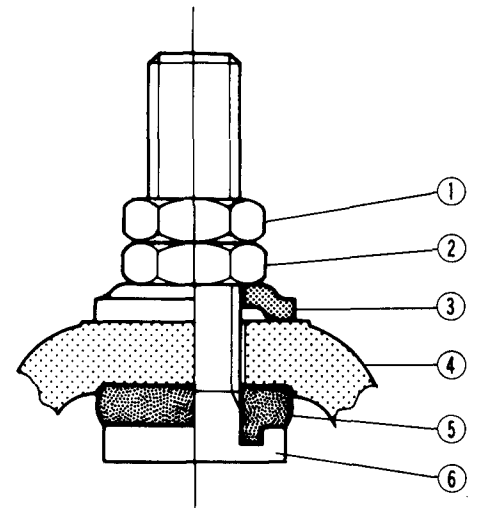

- | | |
|------------|---------------|
| 1. Locknut | 4. Cast Wheel |
| 2. Nut | 5. Grommet |
| 3. Washer | 6. Valve Stem |

- Apply a soap and water solution, or rubber lubricant to the rim flanges, rim protectors, tire beads, and tire irons.

- Check the tire rotation mark on the rear tire and install it on the rim accordingly.

NOTE: The direction of the tire rotation is shown by an arrow on the tire sidewall.

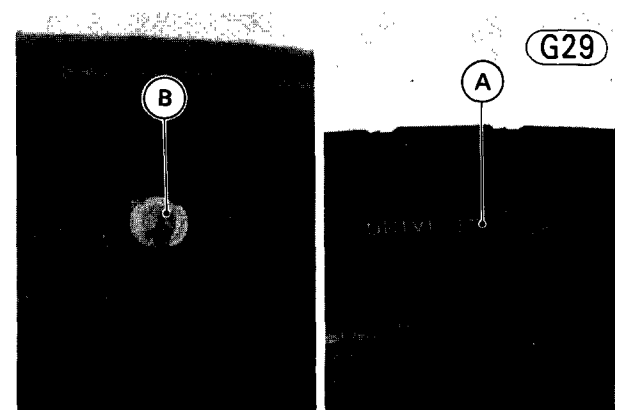

A. Rotation Mark (Arrow)

118 DISASSEMBLY—CHASSIS

- Position the tire on the rim so that the valve is at the tire balance mark (the chalk mark made during removal, or the yellow paint mark on a new tire).
- Fit the rim protectors on the rim flange near the valve stem.
- By hand, slide as much as possible of the lower side of the tire bead over the rim flange, starting at the side opposite the valve.
- Use tire irons to install the remaining part of the tire bead which cannot be installed by hand. For easy tire installation, position the part of the bead which is already over the rim flange in the rim well.

NOTE: To prevent rim damage, be sure to place the rim protectors at any place the tire irons are applied.

- Install the other side of the tire bead onto the rim in the same manner.
- Lubricate the tire beads and rim flanges with a soap and water solution or rubber lubricant to help seat the tire beads in the sealing surfaces of the rim while inflating the tire.
- Center the rim in the tire beads, and inflate the tire with compressed air until the tire beads seat in the sealing surfaces.

WARNING Be sure to install the valve core whenever inflating the tire, and do not inflate the tire to more than 4.0 kg/cm² (57 psi). Overinflation can explode the tire with possibility of injury and loss of life.

- Check to see that the rim lines on both sides of the tire sidewalls are parallel with the rim flanges.

Rim Line

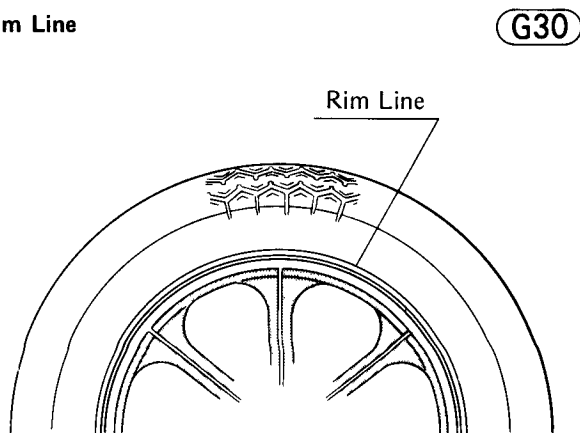

G30

- If the rim lines and tire sidewall lines are not parallel, remove the valve core. Lubricate the rim flanges and tire beads. Install the valve core and inflate the tire again.
- After the tire beads seat in the rim flanges, check for air leaks. Inflate the tire slightly above standard inflation. Use a soap and water solution or submerge it, and check for bubbles that would indicate leakage.
- Adjust the air pressure to the specified pressure (Pg. 193).

DISC BRAKES

Removal, installation, disassembly, and assembly of the disc brake is divided as follows:

Red Removal and Installation

Caliper Removal and Installation Notes

Caliper Disassembly and Assembly Notes

Front Master Cylinder Removal and Installation Notes

Front Master Cylinder Disassembly and Assembly Notes

Brake Hose Replacement

Rear Master Cylinder Removal and Installation Notes

Rear Master Cylinder Disassembly and Assembly Notes

Rear Brake Reservoir Disassembly and Assembly Note

NOTE: Disc removal and disc installation are covered in Wheel Section (Pgs. 115 and 116).

Before working on the disc brake, please read the following:

- CAUTION** 1. Except for the disc pads and disc; use only disc brake fluid, isopropyl alcohol, or ethyl alcohol, for cleaning brake parts. Do not use any other fluid for cleaning these parts. Gasoline, motor oil, or any other petroleum distillate will cause deterioration of the rubber parts. Oil spilled on any part will be difficult to wash off completely, and will eventually deteriorate the rubber used in the disc brake.
2. When handling the disc pads or disc, be careful that no disc brake fluid or any oil gets on them. Clean off any fluid or oil that inadvertently gets on the pads or disc with a high flash-point solvent. Replace the pads with new ones if they cannot be cleaned satisfactorily.
 3. Brake fluid quickly ruins painted surfaces; any spilled fluid should be completely wiped up immediately.
 4. If any of the brake line fittings or the bleed valve is opened at any time, AIR MUST BE BLED FROM THE BRAKE SYSTEM (Pg. 206).
 5. When installing or assembling the disc brake, tighten the disc brake fittings to the values given in Table on Pg. 38. Improper torque may cause the brake to malfunction.

Pad Removal (each caliper):

- Remove the caliper holder shaft bolts (2).

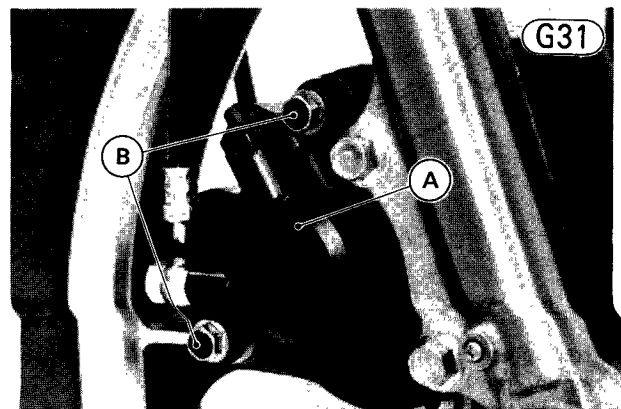

G31

- Lift the caliper off the holder, and remove the pads.

Pad Installation:

- Remove the bleed valve cap on the caliper, attach a clear plastic hose to the bleed valve, and run the other end of the hose into a container.
- Open (loosen) the valve slightly, push the piston in by hand as far as it will go, and then close (tighten) the valve. Wipe up any spilled fluid, and recap the bleed valve. The bleed valve must be tightened to 0.80 kg-m (69 in-lbs) of torque.

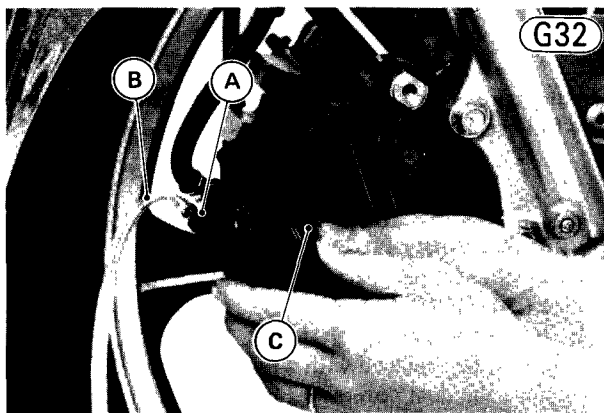

A. Bleed Valve B. Hose C. Piston

- Check that the sliders (2) are in place.
- Fit the pads against the disc.

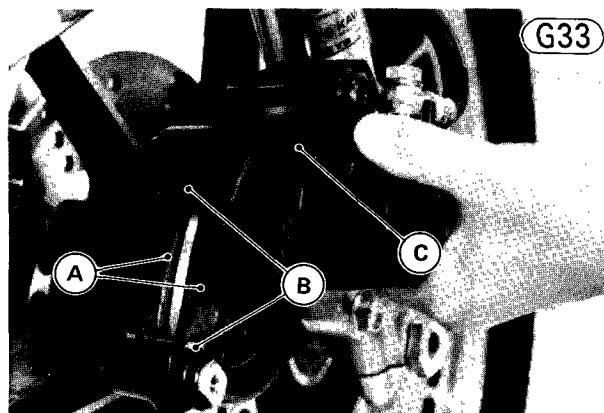

A. Pads B. Sliders C. Anti-Rattle Spring

- Check that the anti-rattle spring is in place. If it was removed, install it to the caliper as shown in Fig. G40.
- Install the caliper, and tighten the caliper holder shaft bolts to 1.8 kg-m (13.0 ft-lbs) of torque.
- Since some brake fluid was lost when the bleed valve was opened, check the fluid level in the master cylinder

- Check the brake.

WARNING Do not attempt to drive the motorcycle until a full brake lever or pedal is obtained by pumping the brake lever or pedal until the pads are against the disc. The brake will not function on the first application of the lever or pedal if this is not done.

Caliper Removal (each caliper):

- If the caliper is to be disassembled, loosen the caliper holder shaft bolts ⑨ (2).

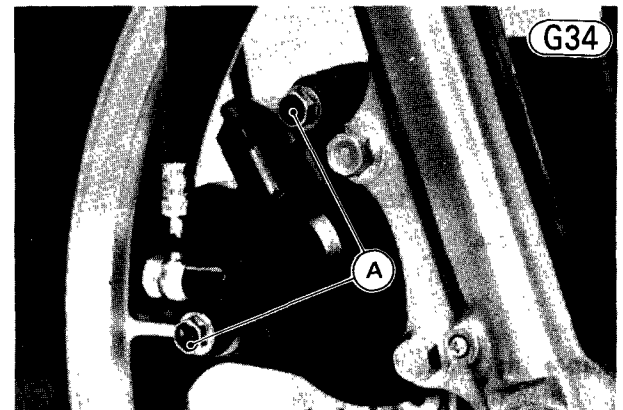

A. Holder Shaft Bolts

NOTE: If the caliper is to be disassembled after caliper removal and compressed air is not available, remove the piston using the following two steps before disconnecting the brake hose fitting from the caliper.

- Remove the pads (Pg. 118).
- Pump the piston out with the brake lever or pedal.
- Remove the banjo bolt at the caliper, and temporarily secure the end of the brake hose to some high place to keep fluid loss to a minimum. There is a flat washer on each side of the hose fitting.

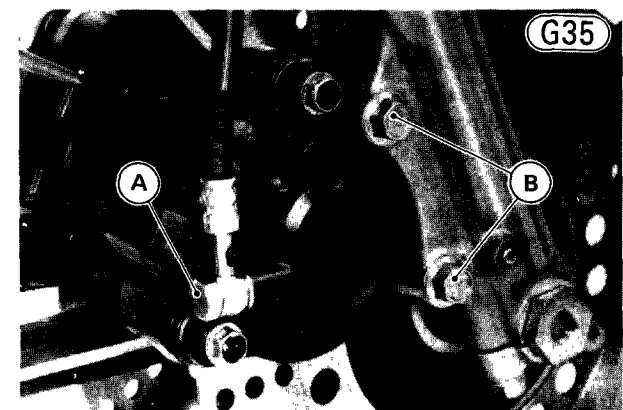

A. Banjo Bolt B. Mounting Bolts

- For the front brake caliper, remove the mounting

120 DISASSEMBLY—CHASSIS

- For the rear brake caliper, remove the rear wheel (Pg. 110), and remove the rear torque link nut, lock-washer, and bolt. Then, pull the axle and take off the rear caliper.

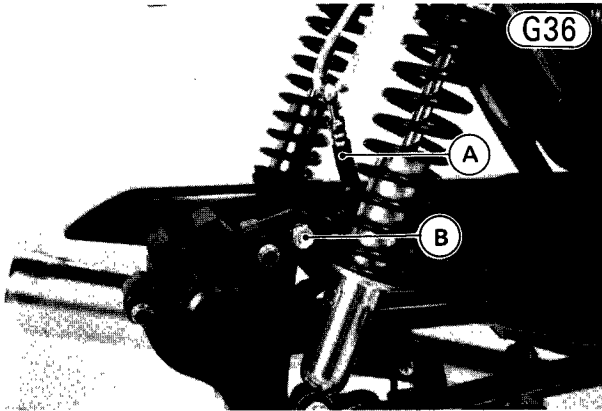

A. Brake Hose B. Torque Link Nut

Caliper Installation Notes (each caliper):

1. Tighten the front caliper mounting bolts to 4.0 kg-m (29 ft-lbs) of torque.
2. Tighten the caliper holder shaft nuts to 1.8 kg-m (13.0 ft-lbs) of torque.
3. Connect the brake hose to the caliper putting a new flat washer on each side of the brake hose fitting. Tighten the banjo bolt to 2.5 kg-m (18.0 ft-lbs) of torque.
4. Check the fluid level in the master cylinder, and bleed the brake line (Pg. 206).

WARNING Do not attempt to drive the motorcycle until a full brake lever or pedal is obtained by pumping the brake lever or pedal until the pads are against the disc. The brake will not function on the first application of the lever or pedal if this is not done.

Caliper Disassembly (each caliper):

- Remove the caliper holder shaft bolts ⑨ (2), and pull out the caliper holder ⑦ or ⑱ and the pads ⑰ (2).
- Remove the holder shafts ④ and ⑭ with the dust covers ⑤. There is the friction boot ⑮ on the shaft ⑭ that diameter is smaller than the other.
- Remove the anti-rattle spring ⑩.
- Remove the dust seal ⑬ around the piston ⑫.
- Cover the caliper opening with a clean, heavy cloth, and remove the piston by lightly applying compressed air to where the brake line fits into the caliper.

WARNING To avoid serious injury, never place your fingers or palm inside the caliper opening. If you apply compressed air into the caliper, the piston may crush your hand or fingers.

NOTE: If compressed air is not available, reconnect the brake line and pump the piston out with the brake

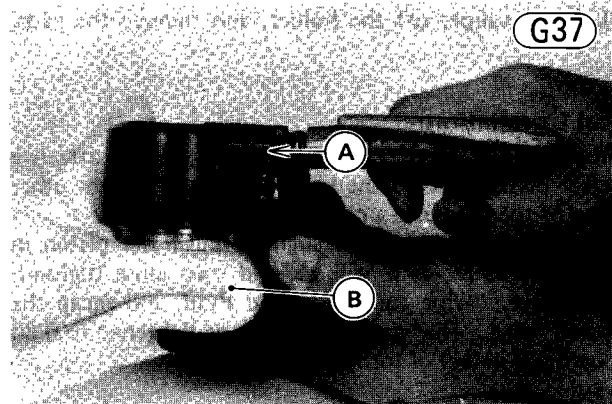

A. Compressed Air B. Heavy Cloth

- Taking care not to damage the cylinder surface, remove the fluid seal ⑪ with a hook.

Caliper Assembly Notes (each caliper):

1. Clean the caliper parts with brake fluid or alcohol (See CAUTION – Pg. 118).
2. It is recommended that the fluid seal, which is removed, be replaced with a new one.
3. Replace the dust covers and friction boot if they were damaged.
4. Apply brake fluid to the outside of the piston and the fluid seal, and push the piston into the cylinder by hand. Take care that neither the cylinder nor the piston skirt get scratched.
5. Install the dust seal around the piston. Check that the dust seal is properly fitted into the grooves in the piston and caliper.

Caliper Dust Seal, Fluid Seal

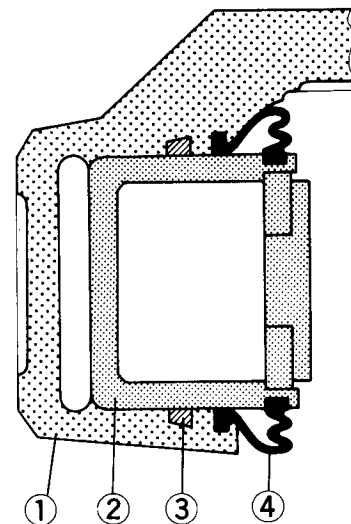

1. Caliper

3. Fluid Seal

122 DISASSEMBLY—CHASSIS

6. Apply a thin coat of PBC (Poly Butyl Cuprysil) grease to the caliper holder shafts and holder holes. (PBC is a special high temperature, water-resistant grease).
7. Install the anti-rattle spring to the caliper as shown.

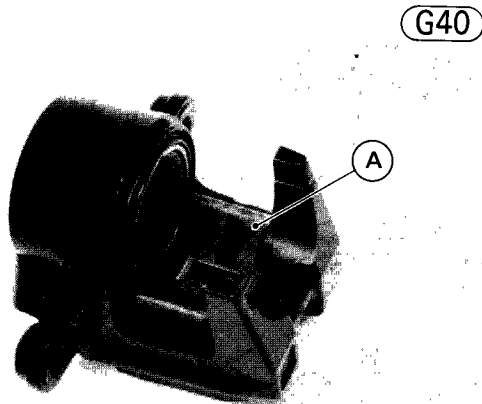

A. Anti-rattle Spring

8. Do not forget to tighten the holder shaft bolts after installing the caliper on the motorcycle (Pg. 120).

Front Master Cylinder Removal:

- Take off the right rear view mirror.
- Using a thin-bladed screwdriver or some other suitable tool, press in the front brake switch tab which catches in the hole in the underside of the master cylinder, and then remove the switch.

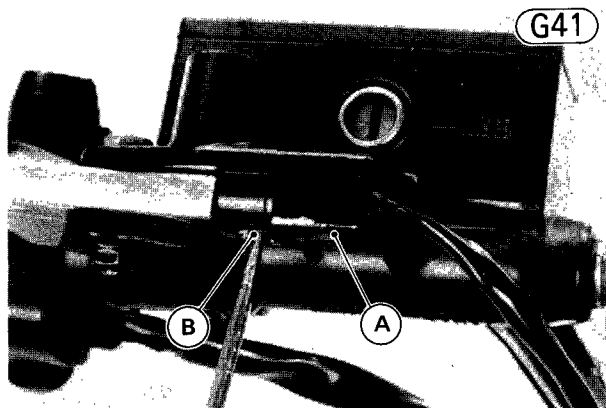

A. Front Brake Switch B. Switch Tab

- Pull back the dust cover, and remove the banjo bolt to disconnect the upper brake hose from the master cylinder. There is a flat washer on each side of the hose

G42

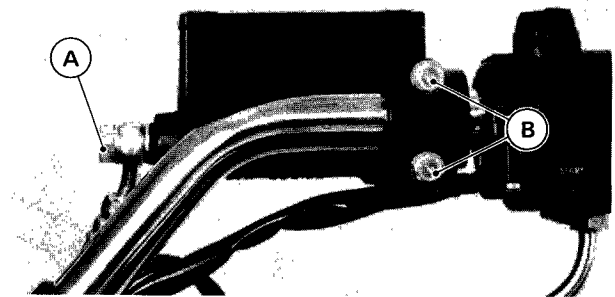

A. Banjo Bolt B. Clamp Bolts

- Remove the clamp bolts (2), and take off the master cylinder. There is a flat washer for each master cylinder clamp bolt. Immediately wipe up any brake fluid that spills.

Front Master Cylinder Installation Notes:

1. The master cylinder clamp is installed with the small projection towards the throttle grip. Tighten the upper clamp bolt first, and then the lower clamp bolt both to 0.90 kg-m (78 in-lbs) of torque.

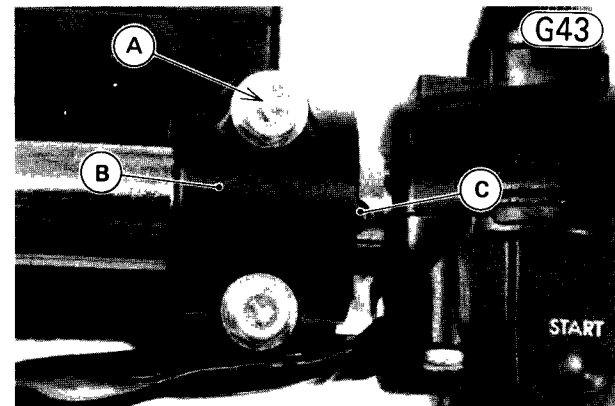

A. Tighten the upper clamp bolt first.
B. Clamp C. Projection

2. Use a new flat washer on each side of the brake hose fitting. Tighten the banjo bolt to 2.5 kg-m (18.0 ft-lbs) of torque.
3. Bleed the brake line after master cylinder installation (Pg. 206).

Front Master Cylinder Disassembly:

- Remove the screws (2) (2), take off the master cylinder cap (2) and disassemble (2) and remove out the bush

Front Master Cylinder

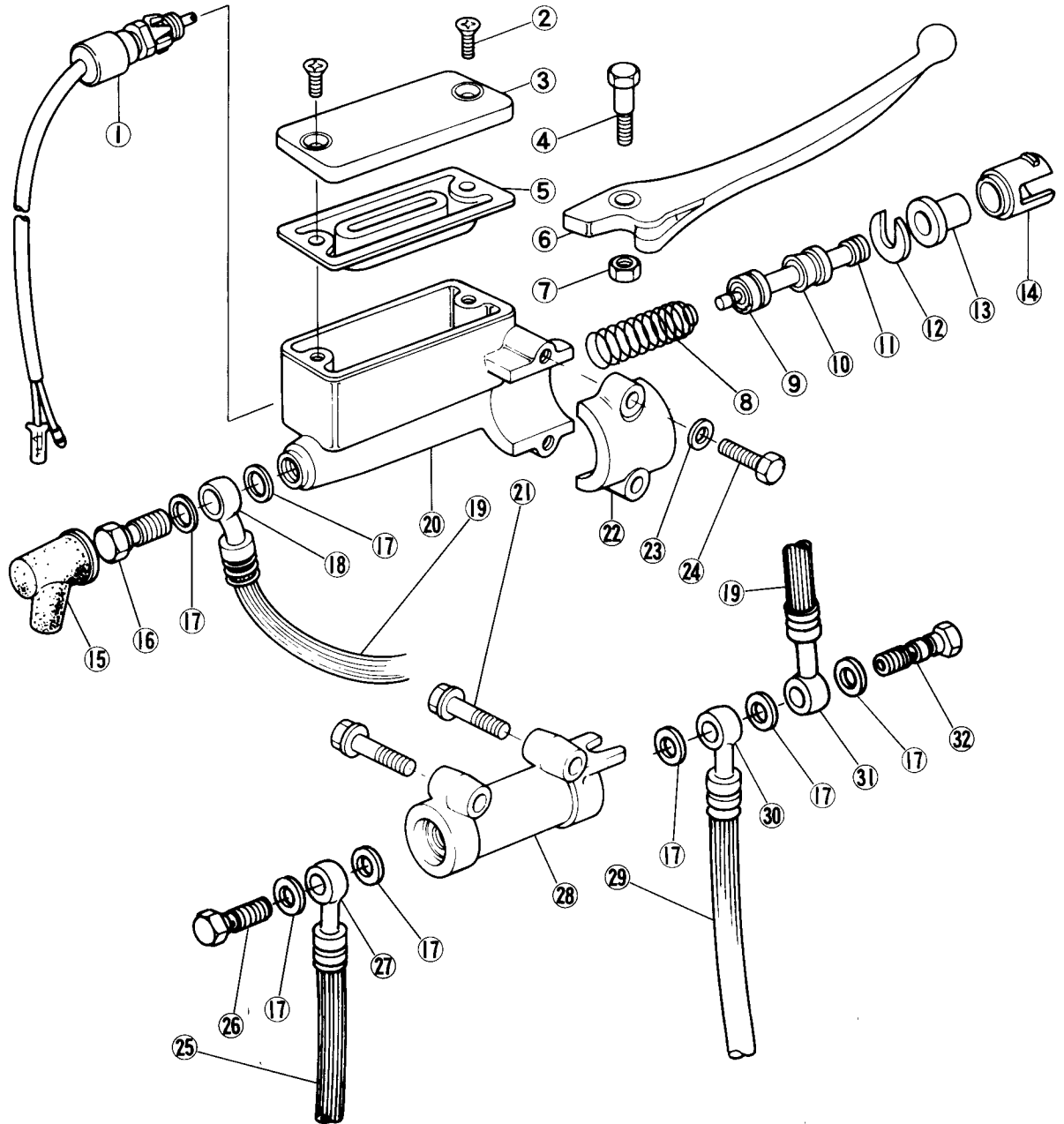

- | | | | |
|-----------------------------|--------------------------|---------------------------|----------------------------|
| 1. Front Brake Light Switch | 9. Primary Cup | 19. Upper Brake Hose | 29. Lower Right Brake Hose |
| 2. Screw | 10. Secondary Cup | 20. Master Cylinder Body | 30. Hose Fitting |
| 3. Master Cylinder Cap | 11. Piston | 21. Mounting Bolt | 31. Hose Fitting |
| 4. Brake Lever Pivot Bolt | 12. Piston Stop | 22. Master Cylinder Clamp | 32. Banjo (Fitting) Bolt |
| 5. Diaphragm | 13. Dust Seal | 23. Flat Washer | |
| 6. Brake Lever | 14. Liner | 24. Clamp Bolt | |
| 7. Locknut | 15. Dust Cover | 25. Lower Left Brake Hose | |
| | 16. Banjo (Fitting) Bolt | 26. Banjo (Fitting) Bolt | |
| | 17. Flat Washer | 27. Hose Fitting | |

124 DISASSEMBLY—CHASSIS

- Remove the locknut (7) and pivot bolt (4), and remove the brake lever (6).
- Using a thin-bladed screwdriver or some other suitable tool, press in the liner tabs which catch in the holes in the master cylinder, and then remove the liner (14).

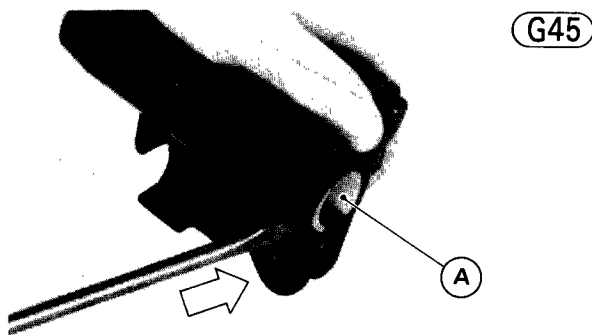

A. Liner

- Pull out the piston (11) and spring (8).
- Remove the spring (8), dust seal (13), and piston stop (12) from the piston.

Front Master Cylinder Assembly Notes:

1. Before assembly, clean all parts including the master cylinder with brake fluid or alcohol (See CAUTION — Pg. 118). Apply brake fluid to the parts removed and to the inner wall of the cylinder.
2. Be sure that the piston stop (12) is between the piston and dust seal (13).

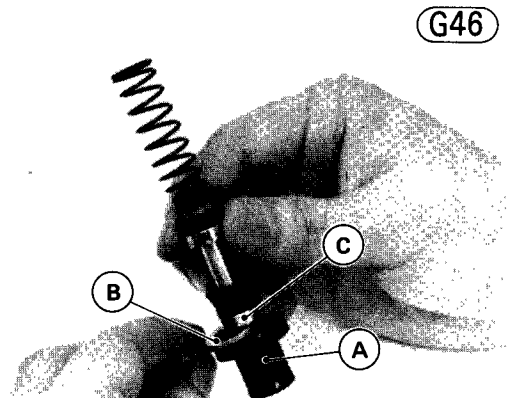

A. Dust Seal B. Piston Stop C. Piston

3. Tighten the brake lever pivot bolt to 0.30 kg-m (26 in-lbs) of torque, and tighten the locknut to 0.60 kg-m (52 in-lbs) of torque.

Rear Master Cylinder Removal:

- Remove the banjo bolt to disconnect the brake hose

each side of the hose fitting. Immediately wipe up any brake fluid that spills.

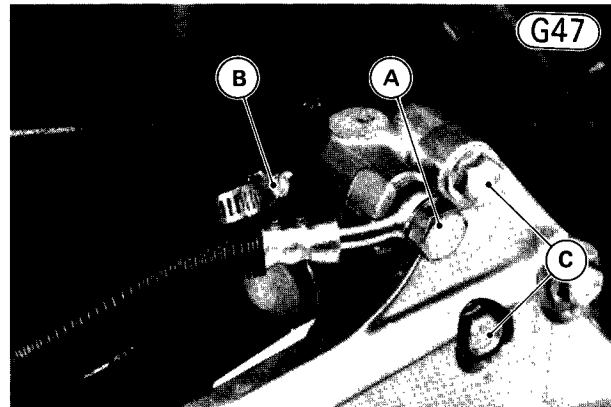

A. Banjo Bolt B. Clamp C. Mounting Bolts

- Loosen the clamp screw, disconnect the brake hose from the reservoir cup, and temporarily secure the end of the brake hose to some high place to keep fluid loss to a minimum.
- Loosen the master cylinder mounting bolts (2).
- Remove the brake pedal bolt and pedal.
- Use a jack under the right muffler or other suitable means to hold the muffler in place.
- Remove the rear footpeg mounting bolt, nut, and flat washer.
- Remove the muffler mounting bracket bolts (2).
- Free the rear brake light switch from the frame bracket.

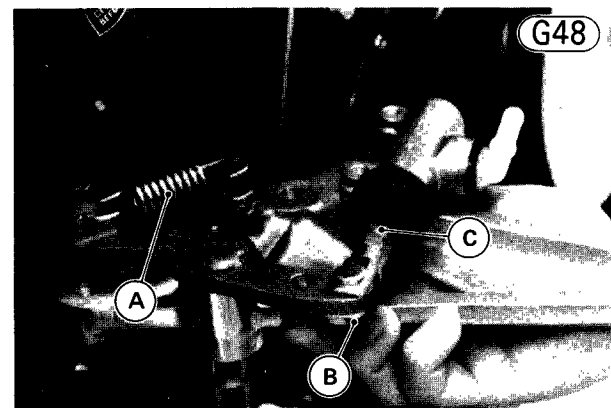

A. Return Spring B. Cotter Pin C. Push Rod

- Remove the brake pedal return spring.
- Remove the cotter pin, and take out the clevis and flat washer to separate the brake pedal shaft arm from the brake push rod.
- Remove the master cylinder mounting bolts (2) and

Rear Master Cylinder Installation Notes:

1. Use a new flat washer on each side of the brake hose fitting, and tighten the banjo bolt to 2.5 kg-m (18.0 ft-lbs) of torque. Be sure that the metal pipe is properly fitted into the U-shaped notch in the master cylinder.
2. Tighten the brake hose clamp screw to 0.10 kg-m (9 in-lbs) of torque.
3. Tighten the rear master cylinder mounting bolts (2) securely after installing the muffler mounting bracket.
4. Install the brake pedal so that the line mark on the pedal is aligned with the punch mark on the shaft.
5. Check and adjust the following items.
 - Rear brake (Pg. 24)
 - Rear brake light switch (Pg. 25)

Do not remove the secondary cup ⑤, primary cup ③, and return spring ② from the piston since remove will damage them.

G49

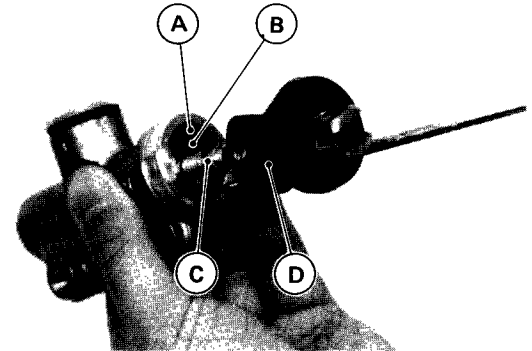

A. Retainer
B. Piston Stop

C. Push Rod
D. Dust Cover

Rear Master Cylinder Disassembly:

- Slide the push rod dust cover ⑦ out of its place.
- Remove the retainer ⑥ with a thin screwdriver, and pull out the piston stop ⑧, push rod ⑨, and piston ④.

Rear Master Cylinder, Reservoir

G50

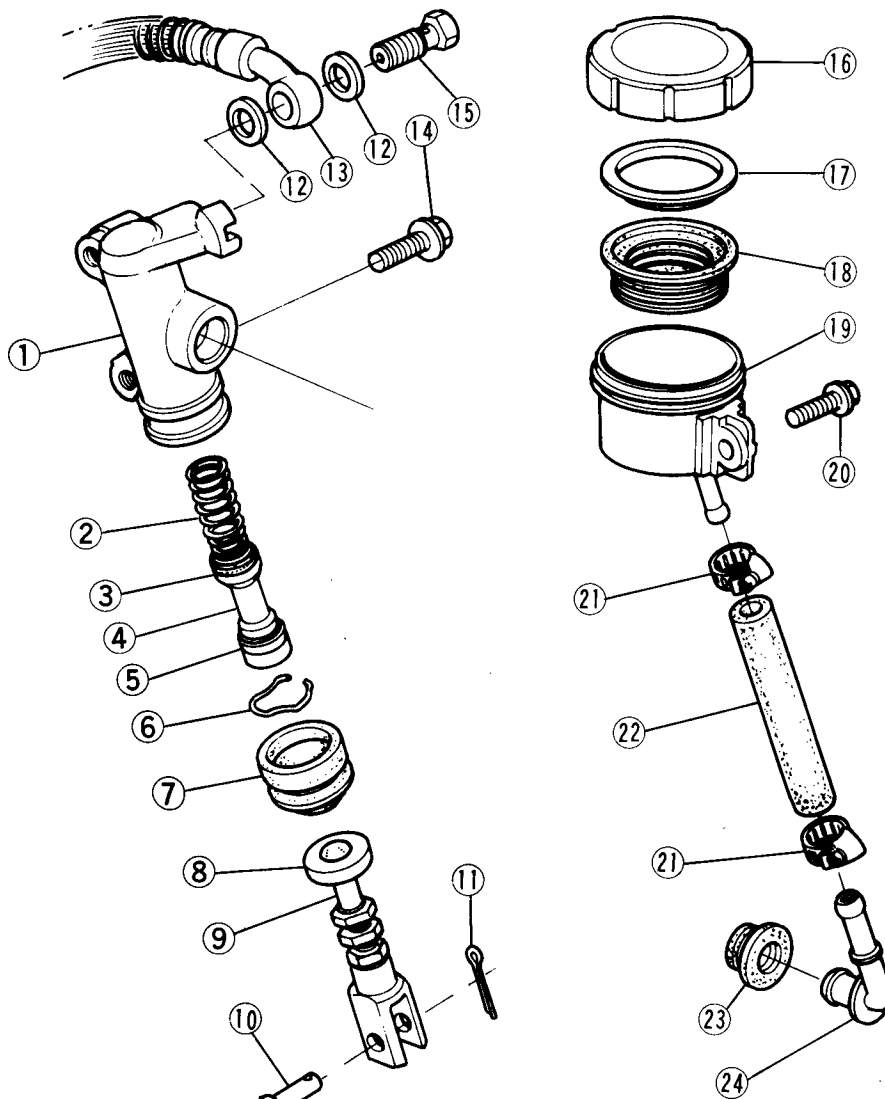

1. Master Cylinder
2. Return Spring
3. Primary Cup
4. Piston
5. Secondary Cup
6. Retainer
7. Dust Cover
8. Piston Stop
9. Push Rod
10. Clevis
11. Cotter Pin
12. Flat Washer
13. Hose Fitting
14. Mounting Bolt
15. Banjo Bolt
16. Cap
17. Ring Plate
18. Diaphragm
19. Reservoir
20. Mounting Bolt
21. Hose Clamp
22. Hose
23. Grommet
24. Grommet

126 DISASSEMBLY—CHASSIS

Rear Master Cylinder Assembly Notes:

1. Before assembly, clean all parts including the master cylinder with brake fluid or alcohol (See CAUTION — Pg. 118), and apply brake fluid to the removed parts and the inner wall of the cylinder. Take care not to scratch the piston or the inner wall of the cylinder.
2. When assembling the rear master cylinder parts, they must be assembled correctly.

Rear Master Cylinder Installation

G51

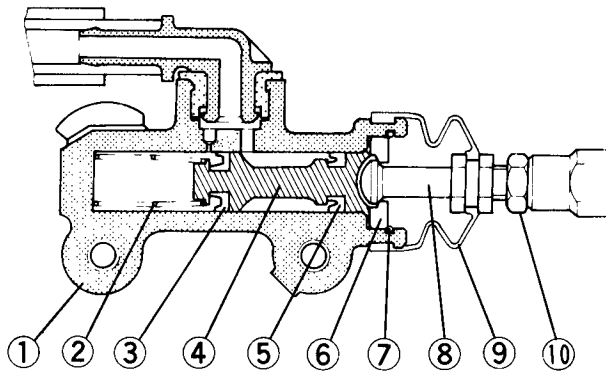

- | | |
|-------------------------|----------------|
| 1. Master Cylinder Body | 6. Piston Stop |
| 2. Spring | 7. Retainer |
| 3. Primary Cup | 8. Push Rod |
| 4. Piston | 9. Dust Cover |
| 5. Secondary Cup | 10. Locknut |

Rear Brake Reservoir Disassembly:

- Remove the rear brake reservoir mounting bolt, ⑳ and take the reservoir ㉑ off the frame.

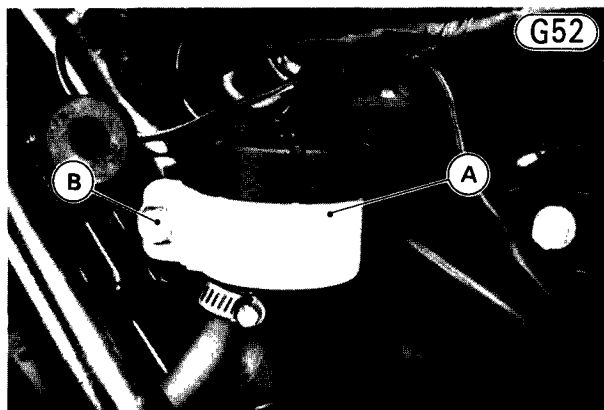

- A. Reservoir B. Mounting Bolt

- Take off the reservoir cap ㉒ and diaphragm ㉓, and

- Loosen the hose clamps ㉔, and pull the brake hose ㉕ off the reservoir. Immediately wipe up any brake fluid that spills.

Rear Brake Reservoir Assembly Notes:

1. Tighten the brake hose clamp screw to 0.10 kg-m (9 in-lbs) of torque.
2. Fill the reservoir with fresh brake fluid, and bleed the brake line (Pg. 206).

Brake Hose Replacement:

- Pump the brake fluid out of the line as explained in the Maintenance Section — *Changing the brake fluid* (Pg. 206).
- Remove the banjo bolts at both end of the brake hose, and pull the hose off the motorcycle. Especially, for the brake hose between the rear master cylinder and the reservoir, loosen the clamps at both end of the hose, and take off the hose.
- Install the new brake hose in its place, and tighten the banjo bolts to 2.5 kg-m (18.0 ft-lbs) of torque, noting the following:
 - Use a new flat washer for each side of the fittings.
 - Be sure that the metal pipe is properly fitted into the U-shaped notch in the 2-way joint, front calipers, and rear master cylinder.

G53

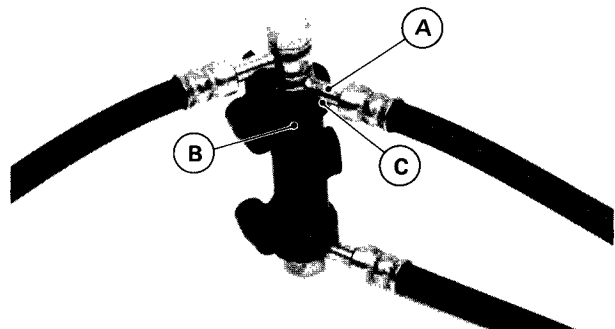

- A. Metal Pipe C. Notch
B. Joint

- Be sure that the metal pipe to the right of the stop on the rear caliper.

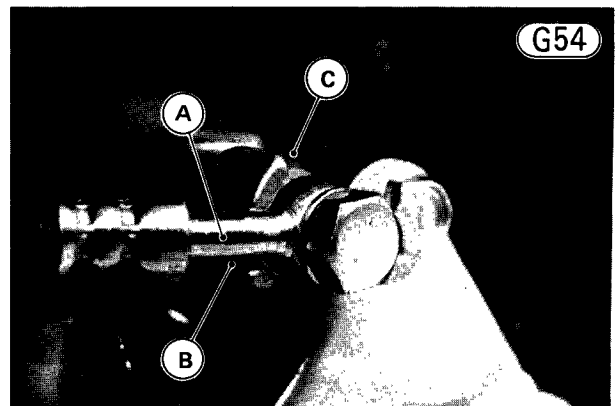

G54

- For the hose between the rear master cylinder and the reservoir, tighten the hose clamps firmly.
- Fill the reservoir with fresh brake fluid, and bleed the brake line (Pg. 206).

CLUTCH CABLE

Removal:

- Remove the engine sprocket cover (Pg. 65).
- Remove the cotter pin, and disconnect the tip of the clutch cable from the clutch release lever.

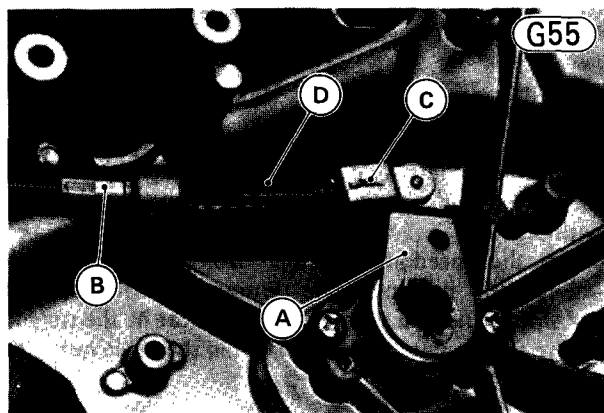

A. Clutch Release Lever C. Cotter Pin
B. Clutch Cable D. Spring

- Loosen the knurled locknut on the clutch lever, and screw in the adjuster.
- Line up the slots in the clutch lever, knurled locknut, and adjuster and free the cable from the lever.
- Pull the cable free from the motorcycle with the clamps.

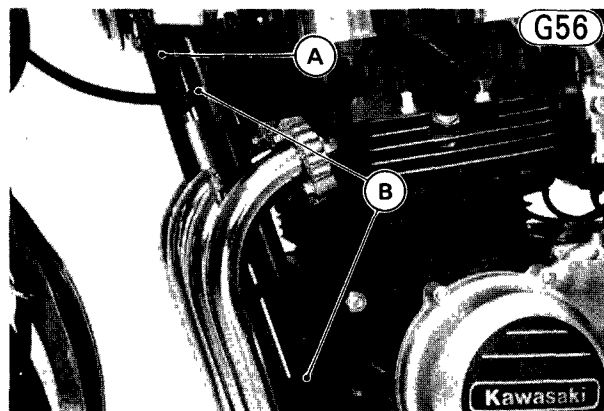

A. Clutch Cable B. Clamps

Installation Notes:

1. Before installing the clutch cable, lubricate it.
2. Fasten the clutch cable to the frame down tube with

3. Adjust the clutch (Pg. 17).

THROTTLE CABLE

Removal:

- Remove the fuel tank (Pg. 43).
- Screw in fully the locknut and adjusting nut at the upper end of the throttle cable so as to give the cable plenty of play.

CAUTION Removing the throttle cable from the carburetors without enough cable play may cause throttle cable damage.

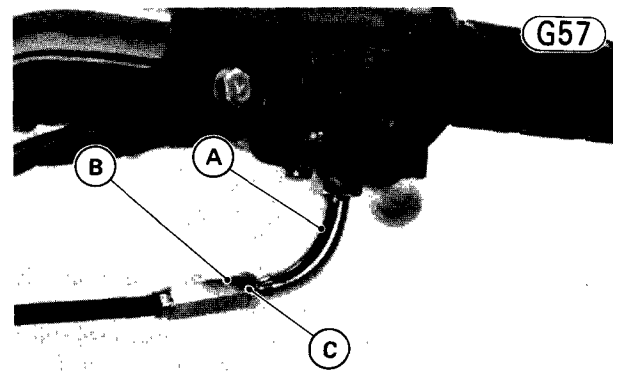

A. Cable Elbow B. Adjusting Nut C. Locknut

- Loosen the throttle cable elbow mounting nuts (2) at the lower end of the throttle cable fully, remove the throttle cable elbow from its bracket, and slip the tip of the inner cable out of the pulley.

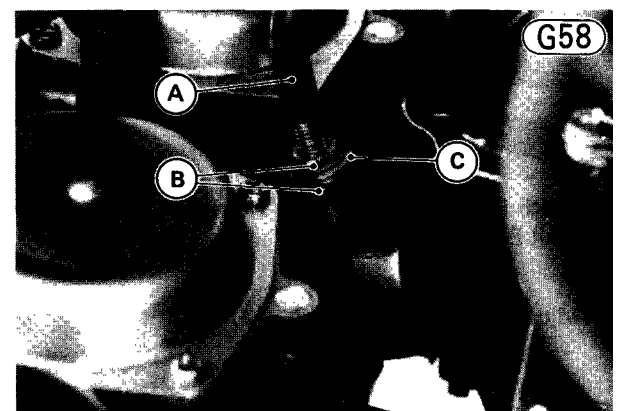

A. Throttle Cable Elbow C. Cable Bracket
B. Mounting Nuts

- Loosen the cable elbow nut, and pull out the cable through the right cable guide on the stem head.
- Remove the right switch housing screws (2), and open

128 DISASSEMBLY—CHASSIS

- Slip the throttle cable tip from its catch in the throttle grip.

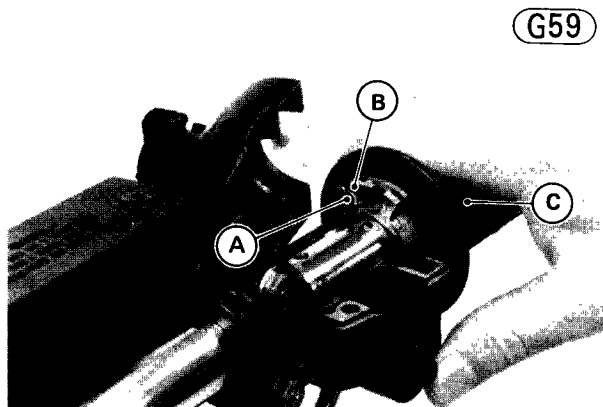

A. Throttle Cable Tip C. Throttle Grip
B. Catch

- Unscrew the throttle cable elbow and pull the cable out of the right switch housing.

Installation Notes:

1. Before installing the throttle cable, lubricate it.
2. The cable should be naturally routed.
3. The upper half of the housing has a small projection which fits into a hole in the handlebar. The front switch housing screw is longer than the rear screw.

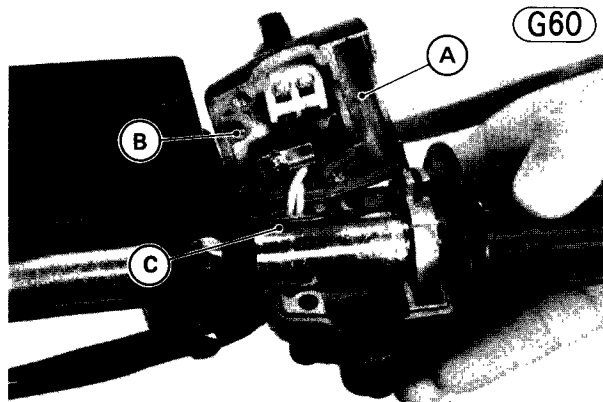

A. Switch Housing C. Hole
B. Small Projection

4. Adjust the throttle cable (Pg. 14).

SPEEDOMETER CABLE

Removal:

- Disconnect the upper and lower ends of the speed-

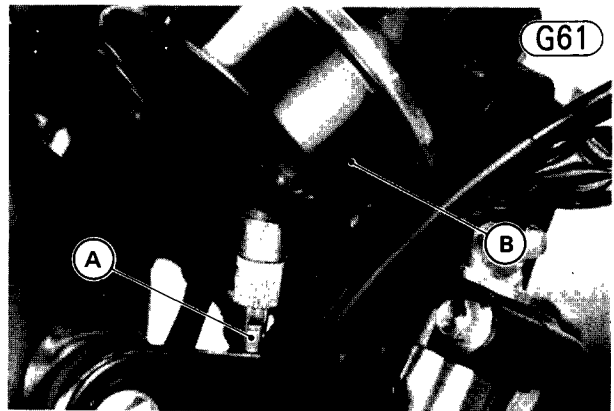

A. Speedometer Cable B. Speedometer

- Pull the cable free.

Installation:

- Run the speedometer cable through its guide at the front fender left side, and stem hose left side and secure the upper end of the cable to the speedometer with pliers.
- Insert the speedometer inner cable into the speedometer gear housing while turning the wheel so that the slot in the end of the cable will seat in the tongue of the speedometer pinion. Tighten the cable nut with pliers.

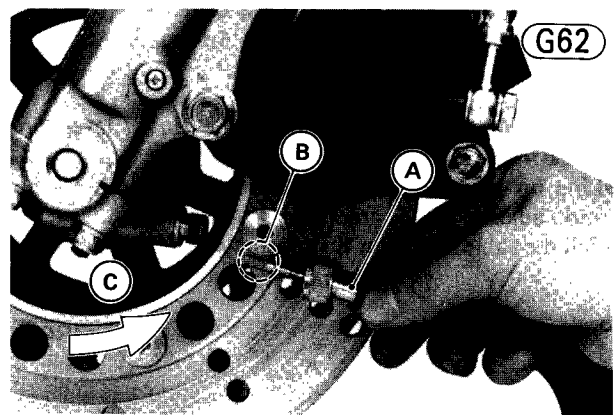

A. Speedometer Cable B. Slot C. Turn.

TACHOMETER CABLE

Removal:

- Disconnect the upper and lower ends of the tachometer cable with pliers.

Installation:

- Run the tachometer cable through its guide at the left side of the stem base, and secure the upper end of the cable to the tachometer with pliers.
- Fit the bottom end of the cable into its place in the cylinder head. Turn it if necessary so that it fits all the way into place, and tighten its nut with pliers. There is a gasket between the outer cable and the tachometer pinion holder.

- Disconnect the headlight socket ⑰ from the rear of the unit. For semi-sealed beam units, the bulb can now be removed.

CAUTION When handling the quartz-halogen bulb, never touch the glass portion with bare hands. Always use a clean cloth. Oil contamination from hands or dirty rags can reduce bulb life or even cause the bulb to explode.

- Remove the pivot screws ①, nuts ⑩, and rubber dampers ⑪ (2 ea), and the beam horizontal adjusting screw ⑨. A nut ⑭, spring seat ⑬, and spring ⑫ come off with the adjusting screw.
- Separate the outer rim ② from the inner rim.
- Remove the screws ⑲ (2), and separate the sealed beam unit from the inner rim ③ and mounting rim ⑯.

HEADLIGHT UNIT

Removal:

- Take out the retaining screws ⑱ (2), and swing the unit ④ or ⑤ from the housing ⑳.

Installation Notes:

1. Place the sealed beam unit into the mounting rim, fitting the raised portion into its holders on the mounting rim. This ensures that the part of the

Headlight

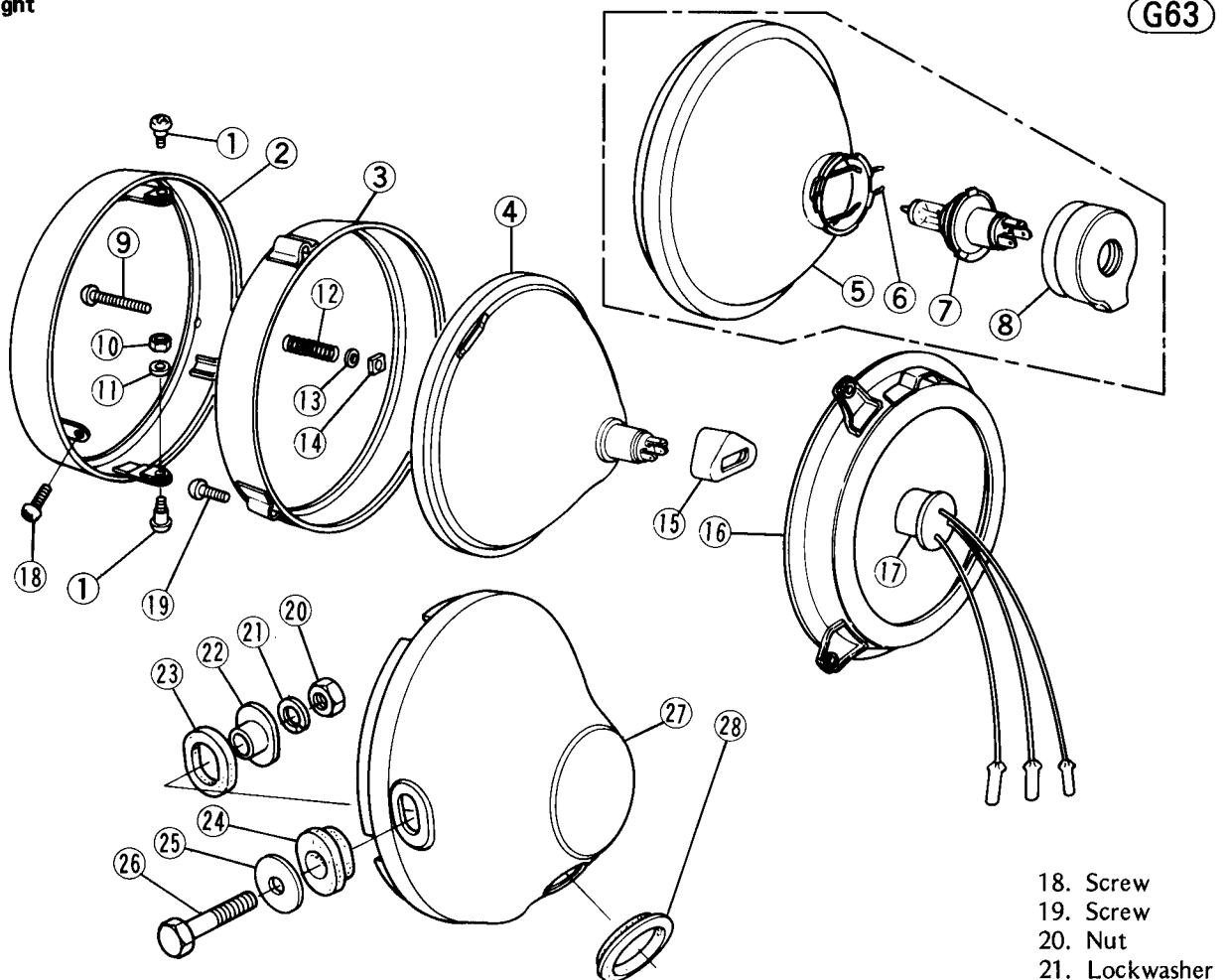

*:KZ750-H only

- 1. Pivot Screw
- 2. Outer Rim
- 3. Inner Rim
- 4. Sealed Beam Unit

- *6. Retaining Spring
- *7. Bulb
- *8. Dust Cover
- 9. Adjusting Screw
- 10. Nut

- 12. Spring
- 13. Spring Seat
- 14. Nut
- 15. Dust Cover
- 16. Mounting Rim

- 18. Screw
- 19. Screw
- 20. Nut
- 21. Lockwasher
- 22. Collar
- 23. Damper
- 24. Damper
- 25. Flat Washer
- 26. Bolt
- 27. Housing

130 DISASSEMBLY—CHASSIS

sealed beam unit marked "TOP" will be on top after the headlight unit is mounted in the headlight housing.

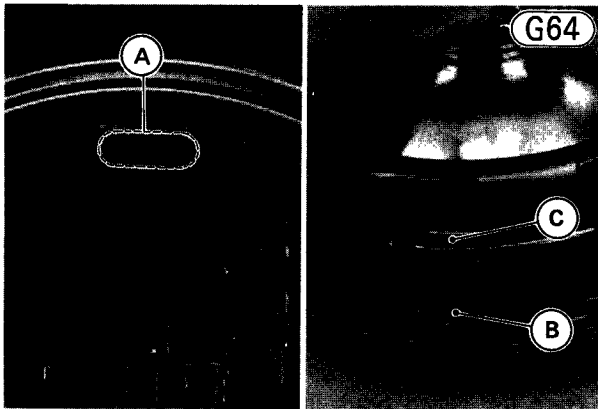

A. "TOP" Mark
B. Raised Portion
C. Holder

- The spring seat on the adjusting screw goes between the spring and the bracket.
- Fit the dust cover onto the bulb firmly as shown in Fig. G65.

Dust Cover Installation

G65

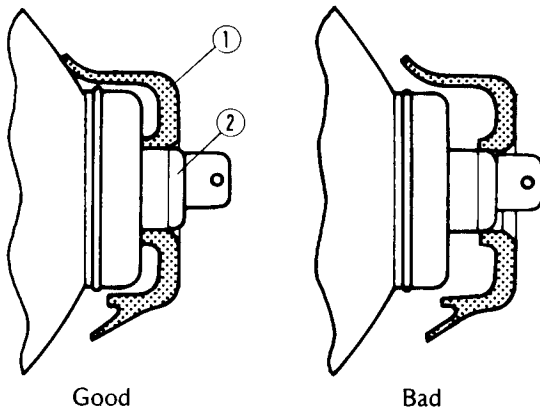

Good

Bad

- Dust Cover
- Headlight Bulb

- Carry out horizontal beam adjustment after installation (Pg. 28).

TURN SIGNAL LIGHTS (TURN SIGNAL/RUNNING POSITION LIGHTS)

Bulb Replacement:

- Remove the lens mounting screws, and take off the

- Press the bulb inward, and holding the bulb in this position, twist it to the left and pull it out.

G66

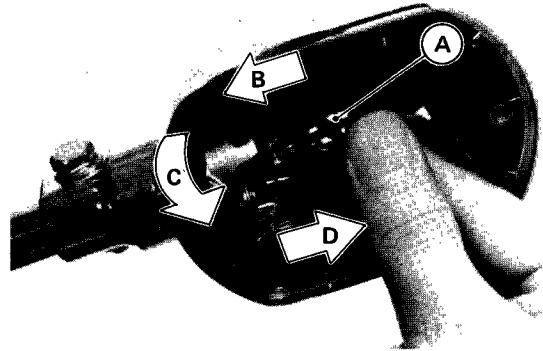

A. Bulb
B. Press.
C. Twist.
D. Pull out.

- Install a new 12 volt bulb of the correct wattage (see the wiring diagram).
- Fit the rubber gasket in place, if removed, and install the lens. Be careful not to overtighten the mounting screws. Each screw has a plastic washer.

TURN SIGNAL ASSEMBLYS

Removal (front, either side):

- Take out the retaining screws (2), pull the bottom of the headlight unit out of its housing, and swing the unit out from the housing.
- Disconnect the headlight socket, and pull out the city light leads from the rear of the unit.
- Disconnect the lead(s) from the turn signal assembly.
- For KZ750-E, remove the mounting nut, and pull the front turn signal assembly from the front fork cover stay.

G67

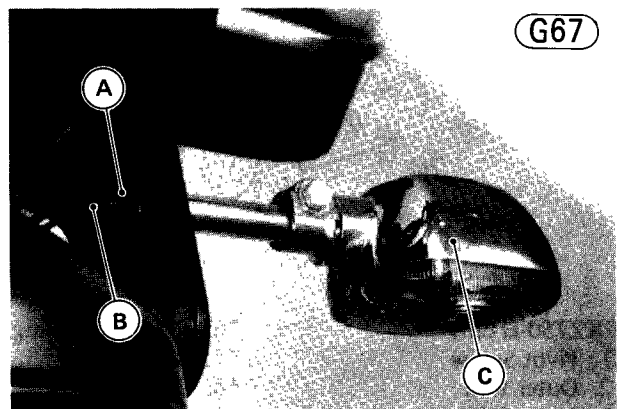

A. Mounting Nut

C. Turn Signal Assembly

●For KZ750-H, remove the bolts, lockwashers, and flat washers (2 ea), and take the clamp, rubber damper, and turn signal assembly off the handlebar.

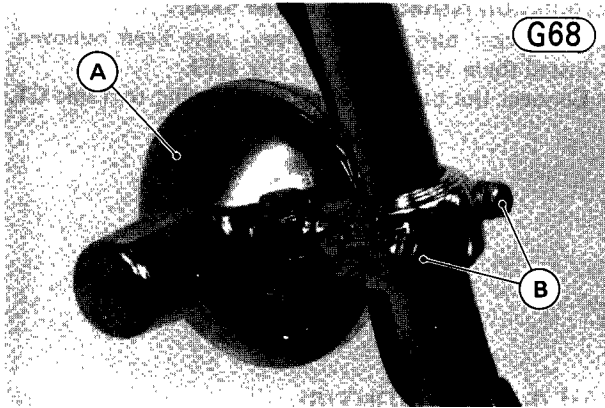

A. Turn Signal Assembly B. Clamp Bolts

Installation Notes (front, either side):

1. Connect the turn signal lead(s) referring to Table G1.

Table G1 Turn Signal Lead Color

	Turn Signal Lead	Main Wiring Harness Lead
Right	Green (*Gray)	↔ Gray
	*Blue	↔ *Blue (†Red/Blue)
	Black/Yellow (†Black)	↔ Black/Yellow
Left	Green (*Gray)	↔ Green
	*Blue	↔ *Blue (†Red/Blue)
	Black/Yellow (†Black)	↔ Black/Yellow

*: US and Canadian models
†: KZ750-H for US and Canada

2. Adjust the headlight (Pg. 28) after installation.

Front and Rear Turn Signals

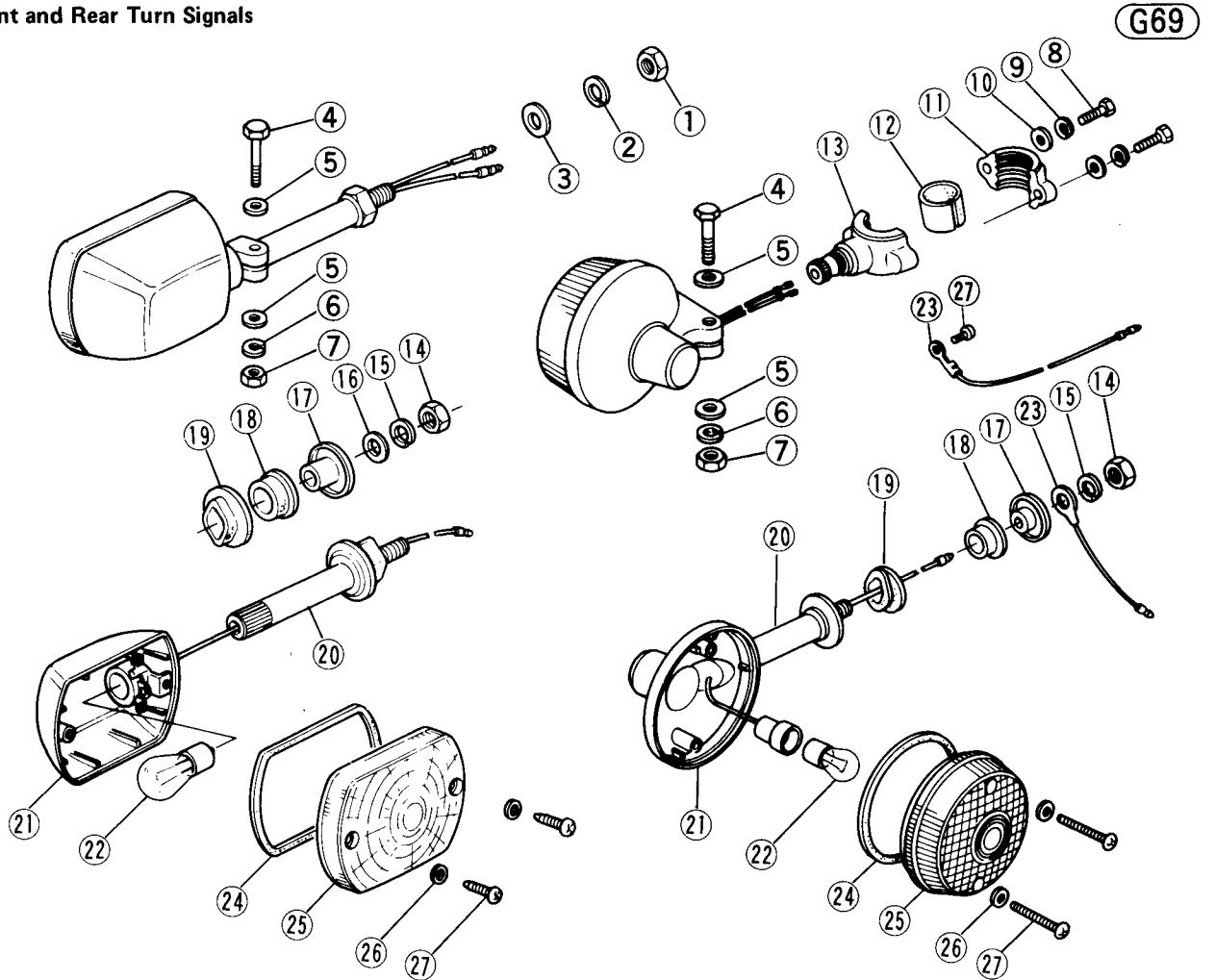

- | | | | |
|----------------|-------------------|-----------------|-----------------|
| 1. Nut | 8. Bolt | 15. Lockwasher | 22. Bulb |
| 2. Lockwasher | 9. Lockwasher | 16. Flat Washer | 23. Ground Lead |
| 3. Flat Washer | 10. Flat Washer | 17. Collar | 24. Gasket |
| 4. Bolt | 11. Clamp | 18. Damper | 25. Lens |
| 5. Flat Washer | 12. Rubber Damper | 19. Damper | 26. Gasket |
| 6. Lockwasher | 13. Bracket | 20. Stay | 27. Screw |

132 DISASSEMBLY—CHASSIS

Removal (rear, either side):

- Unlock the seat and swing it open.
- For KZ750-E, remove the rear fender cover bolts (4) and flat washers (4), and remove the fender cover.

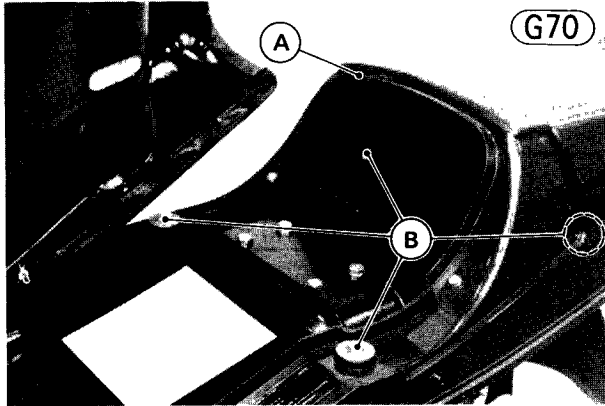

A. Rear Fender Cover B. Bolts

- For KZ750-H, remove the rear seat mounting bolts (4), lockwashers (4), and flat washers (2), and take off the rear seat.

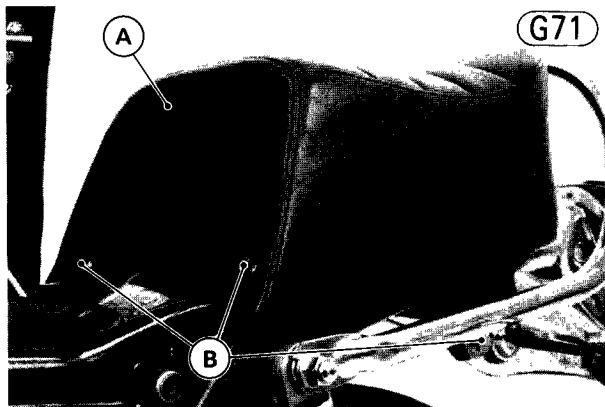

A. Rear Seat B. Mounting Bolts

- Disconnect the turn signal gray lead.

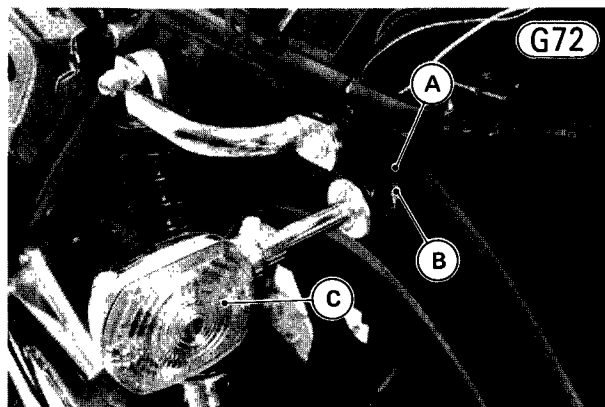

A. Turn Signal Gray Lead C. Turn Signal

- Remove the mounting nut and lockwasher, and pull the rear turn signal from the frame.

Installation Notes (rear, either side):

1. If the rear turn signal dampers have been removed, install them as illustrated in Fig. G69.
2. Connect the turn signal leads according to Table G1.

TAIL/BRAKE LIGHT(S)

Bulb Replacement:

- Remove the lens mounting screws, and take off the lens.
- Press the bulb inwards, and holding the bulb in this position, twist it to the left and pull it out.

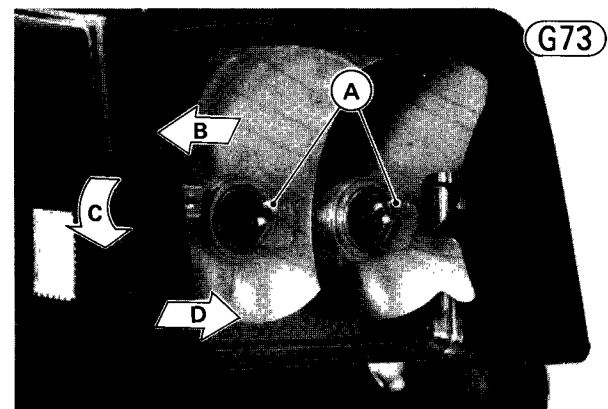

A. Tail/Brake Light Bulbs C. Twist.
B. Press. D. Pull out.

- Replace a burned-out bulb with a new 12 volt bulb of the correct wattage (see the wiring diagram).
- Fit the rubber gasket in place, if removed, and install the lens. Be careful not to overtighten the mounting screws.

INDICATOR LIGHTS

Removal:

- To remove the indicator light in the indicator panel, remove the mounting screws (2), and take off the

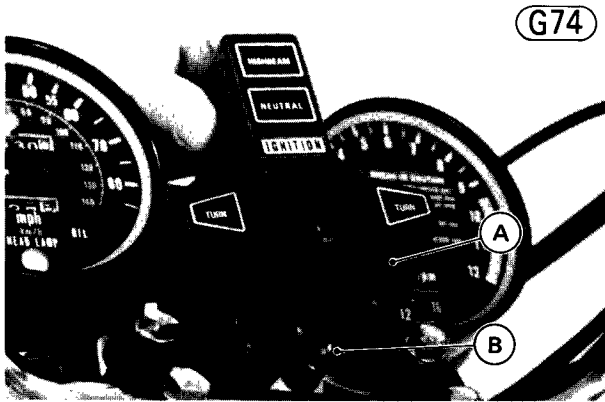

A. Upper Cover B. Bulb

- To remove the indicator light in the meter, remove the meter.
- Pull the indicator light bulb out the bulb holder.
- To remove the indicator light bulb, first press the bulb inwards, then holding the bulb in this position, twist it to the left and pull it out.

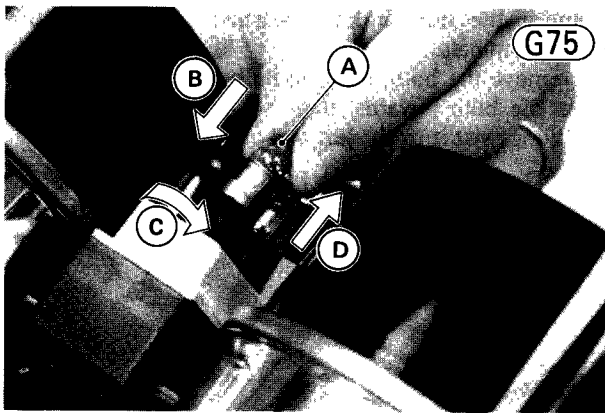

A. Bulb B. Press. C. Twist. D. Pull out.

Installation Note:

- Use the bulbs shown in Table G2 for indicator light replacement. Also, refer to the table for light location by lead color. Example: The right turn signal socket takes the bulb with Black/Yellow and gray leads.

Table G2 Indicator Lights

Bulb Wattage	Indicator Lights	Lead Color
12V 3.4W	Neutral	Brown, Light Green
	High Beam	Red/Black, Black/Yellow
	Left Turn Signal	Green, Black/Yellow
	Right Turn Signal	Gray, Black/Yellow
	Oil	Blue/Red, Brown
	Headlamp	Light Green/Red, Black/Yellow
	Fuel Stop Lamp	Green/White, Brown
	Voltmeter	Brown/White,

SPEEDOMETER, TACHOMETER, METER LIGHTS

Removal:

- Disconnect the upper end of the speedometer cable and tachometer cable with pliers.
 - Remove the cap nuts (2) from the bottom of the meter.
- NOTE:** For KZ750-H, the volt meter is built in the tachometer.

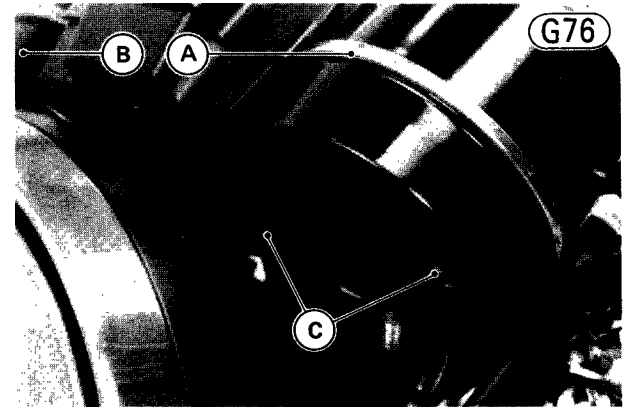

A. Speedometer B. Tachometer C. Cap Nuts

- Pull up the speedometer and tachometer, pull the meter lights and indicator light, and remove the meters.

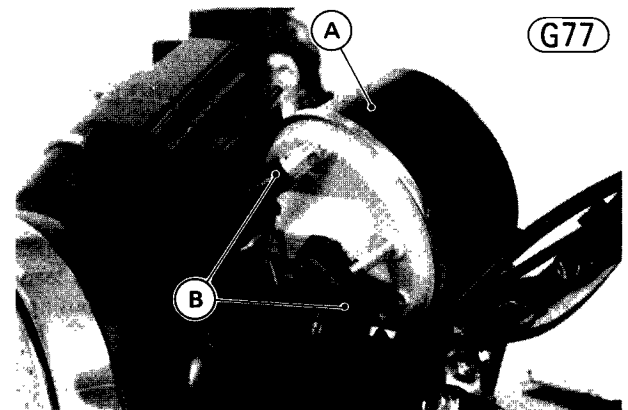

A. Speedometer B. Meter Lights

- To remove the meter light bulb or indicator light bulb, first press the bulb inward, then holding the bulb in this position, twist it to the left and pull it out (Fig. G75).

CAUTION Place the meter so that the correct side of the meter is up. If a meter is left upside down or sideways for any length of time it will malfunction.

Installation Notes:

134 DISASSEMBLY—CHASSIS

- Refer to the table for light location by lead color.
For the indicator light, refer to Table G3.

Table G3 Meter Lights

Bulb Wattage	Lead Color
12V 3.4W	Brown/White, Black/Yellow (*Blue, Black/Yellow)

* : KZ750-H

- There are two rubber dampers between the meter and meter bracket.



A. Meter
B. Rubber Damper
C. Meter Bracket
D. Cover

VOLTMETER, METER LIGHT, INDICATOR LIGHTS (on KZ750-E)

NOTE: For KZ750-H, the voltmeter is built in the tachometer, and cannot be removed from the tachometer.

Removal:

- Remove the headlight unit from headlight housing.
- Disconnect the 6-pin connector and brown/white lead from the indicator panel in the headlight housing.
- Remove the mounting screws (2), and take off the indicator panel assembly.

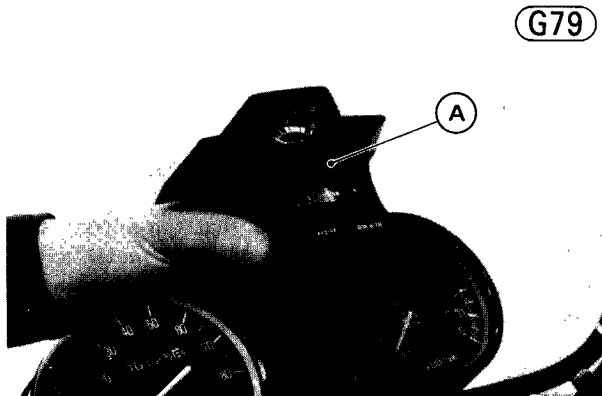

- To remove the upper cover from the panel, remove the mounting screws (2).
- To remove the voltmeter from the panel, remove the voltmeter terminal nuts, and lockwashers (2 ea), and disconnect the meter leads.

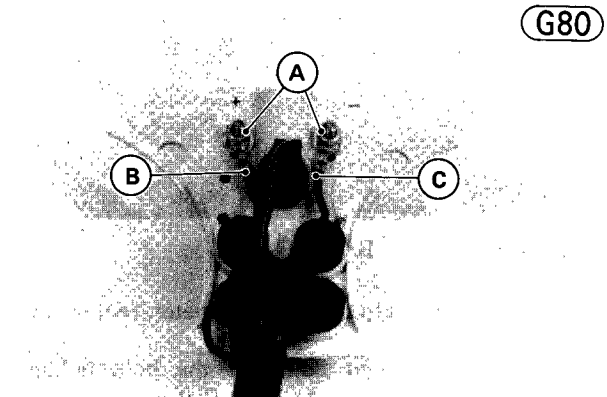

A. Terminal Nuts
B. Meter Brown Lead
C. Meter Black/Yellow Lead

- Remove the nuts and flat washers (2 ea) from the meter terminals.
- To remove the bulb, pull the bulb off the panel. First press the bulb inwards, then holding the bulb in this position, twist it to the left and pull it out.

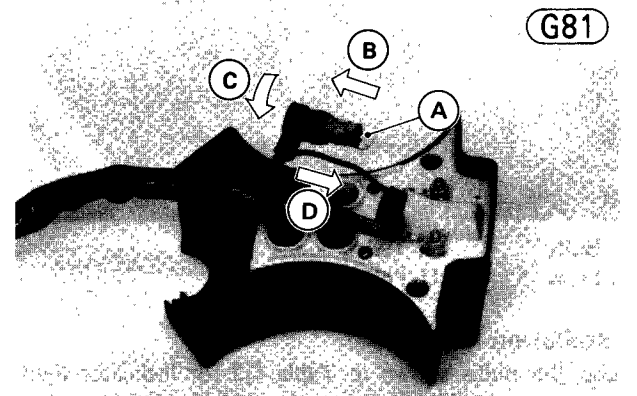

A. Bulb
B. Press
C. Twist
D. Pull out

Installation Notes:

- Connect the meter leads referring to the following.
Brown Lead → Meter (+) Terminal
Black/Yellow Lead → Meter (-) Terminal
- Refer to Table G2 for light location by lead color.

IGNITION SWITCH

Removal:

- Open the headlight housing, and free the headlight unit

- Disconnect the ignition switch wiring harness socket from the plug (6-pin) it connects to in the headlight housing, and push the socket out of the housing.
- Remove the headlight housing mounting bolts, flat washers, lockwashers, and nuts (2 ea).

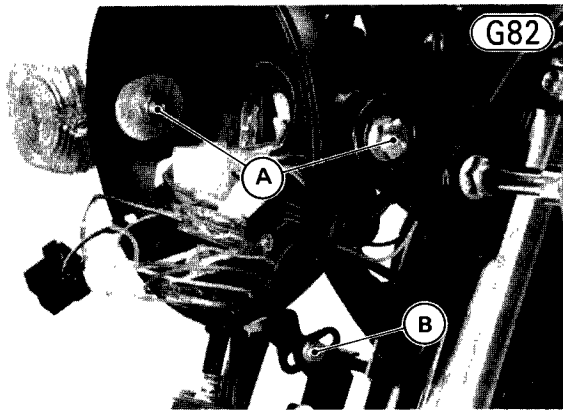

A. Mounting Bolts B. Lower Mounting Bolt

- Remove the headlight housing lower mounting bolt, flat washers, lockwasher, and nut.
- Remove the Allen bolts (2) and lockwashers (2), and pull out the ignition switch.

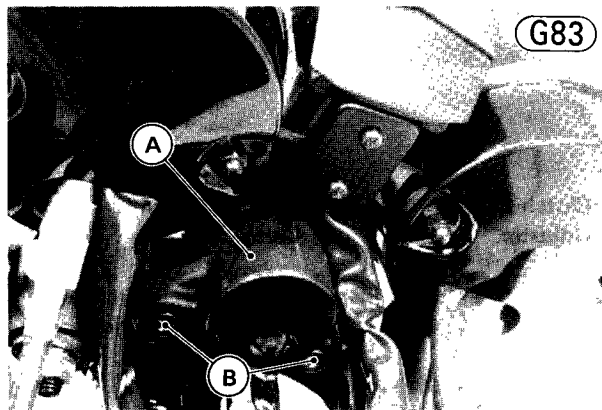

A. Ignition Switch B. Allen Bolts

Installation Note:

- Adjust the headlight (Pg. 28) after installation.

FRONT BRAKE LIGHT SWITCH

Removal:

- Disconnect the front brake light switch brown and blue leads in the headlight housing, and pull the leads out of the housing.
- Using a thin-bladed screwdriver or some other suitable tool, press in the front brake light switch tab which catches in the hole in the underside of the master cylinder, and then remove the switch.

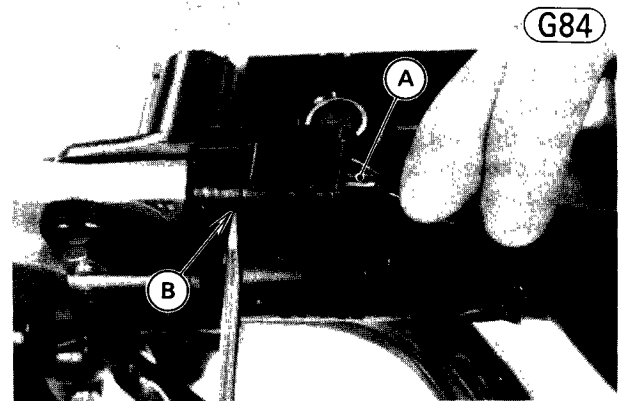

A. Front Brake Light Switch B. Tab

REAR BRAKE LIGHT SWITCH

Removal:

- Remove the right side cover, and disconnect the blue and brown leads from the rear brake light switch.
- Press in the rear brake light switch tabs, and take the rear brake light switch off the bracket and spring.

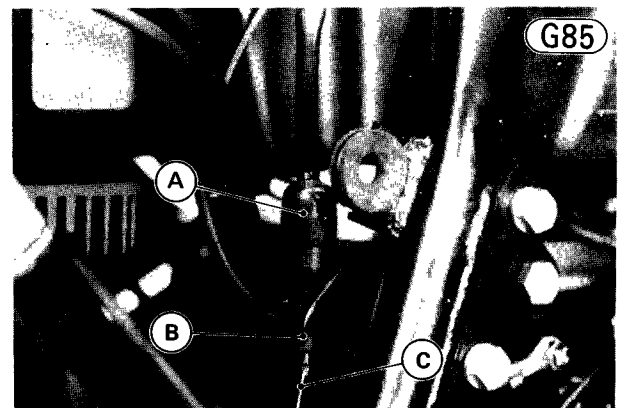

A. Rear Brake Light Switch C. Spring

136 DISASSEMBLY—CHASSIS

Installation Note:

- Adjust the switch after installation (Pg. 25).

STARTER LOCKOUT SWITCH

Removal:

- Remove the fuel tank (Pg. 43), and disconnect the starter lockout switch lead connections.
- Using a thin-bladed screwdriver or some other suitable tool, press in the starter lockout switch tab which catches in the hole in the clutch holder, and then remove the switch.

G86

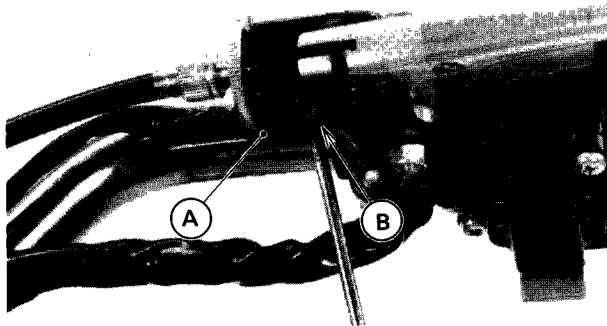

A. Starter Lockout Switch B. Tab

HANDLEBAR

Removal:

NOTE: For KZ750-H, refer to following, noting the next step.

- To remove the front turn signal assemblies, remove the bolts, lockwashers, and flat washers, and take the assembly clamps, rubber dampers, and assemblies off the handlebar.
- Take off the rear view mirrors.
- Remove the fuel tank (Pg. 43) or cover it with a thick cloth to avoid damaging the painted surface.
- Loosen the locknut, and turn in fully the adjuster at the center of the clutch cable to give the cable plenty of play.
- Remove the clutch adjusting cover.
- Loosen the locknut, and turn in the clutch adjusting screw a couple of turns to give the clutch cable plenty

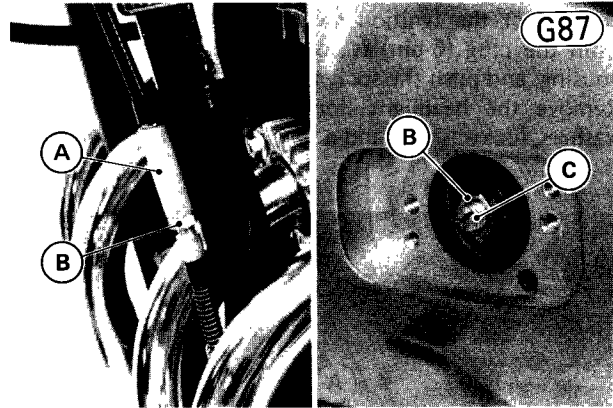

A. Adjusting Nut
B. Locknut

C. Adjusting Screw

- Loosen the knurled locknut on the clutch lever, and turn in the adjuster and line up the slots in the clutch lever, locknut, and adjuster. Free the inner cable from the lever.

G88

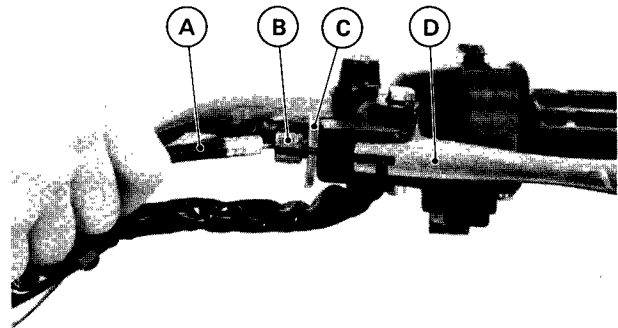

A. Clutch Cable
B. Adjuster

C. Knurled Locknut
D. Clutch Lever

- Remove the straps which hold the left switch wiring harness and right switch wiring harness to the handlebar.
- Take out the left switch housing screws (2), and remove the housing from the handlebar. If necessary, loosen the clutch lever holder bolt, and slide the clutch lever to the right.

G89

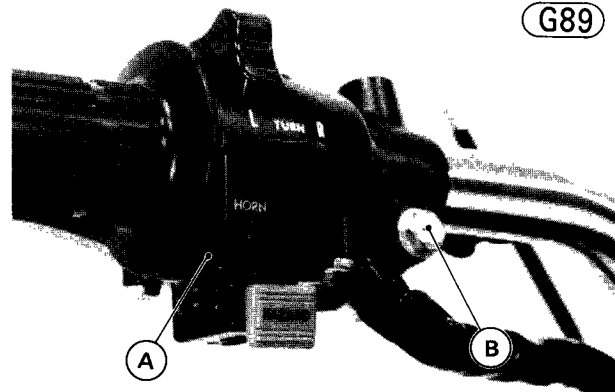

- Loosen the master cylinder clamp bolts (2).

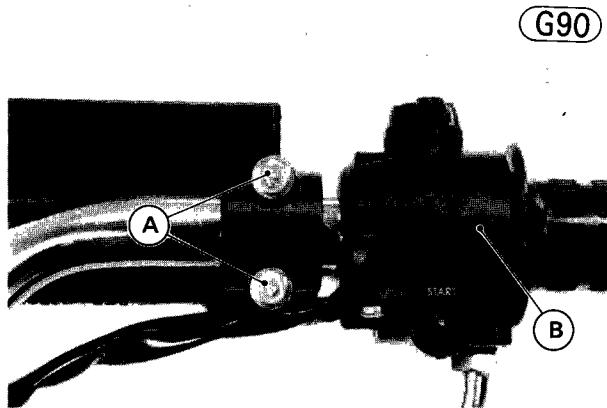

A. Master Cylinder Clamp Bolts
B. Right Switch Housing

- Remove the right switch housing screws (2), and open up the housing.
- Take the starter lockout switch off the clutch holder (Pg. 136).
- Remove the handlebar clamp bolts and lockwashers (4 ea), remove the clamps (2), and slide the handlebar from the throttle grip, right switch housing, and master cylinder or front brake lever holder.

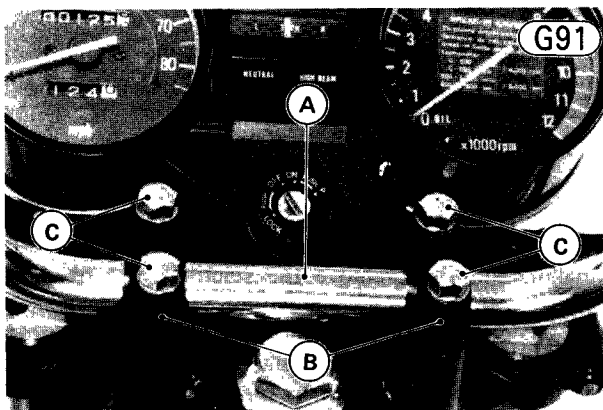

A. Handlebar
B. Handlebar Clamps
C. Clamp Bolts

- To remove the clutch lever, loosen the clutch lever holder bolt, cut off the left handlegrip, which is bonded to the handlebar, and slide off the clutch lever.

Installation Notes:

- If the clutch lever and left handlegrip were removed; slide the clutch lever back on, hand tighten its bolt, and bond as new left handlegrip to the handlebar.
- Mount the handlebar so that the angle of the handlebar matches the angle of the front fork as shown, and tighten the clamp bolts evenly to 1.8 kg-m (13.0

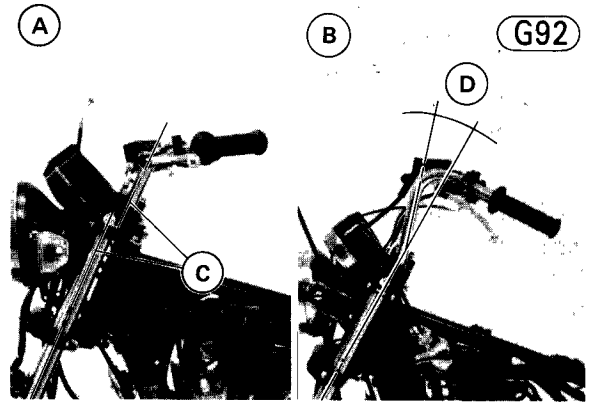

A. KZ750-E B. KZ750-H C. Parallel D. 10°

- The upper half of the right switch housing has a small projection which fits into a small hole in the handlebar. The front switch housing screw is longer than the rear screw.

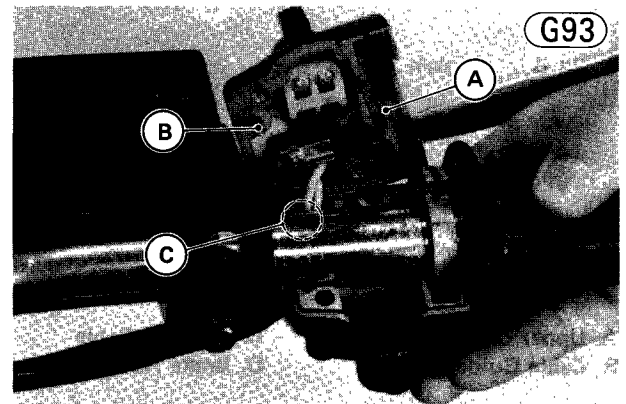

A. Right Switch Housing
B. Projection
C. Hole

- With the brake lever mounted at the proper angle, tighten first the upper and then the lower master cylinder clamp bolt to 0.90 kg-m (78 in-lbs) of torque.

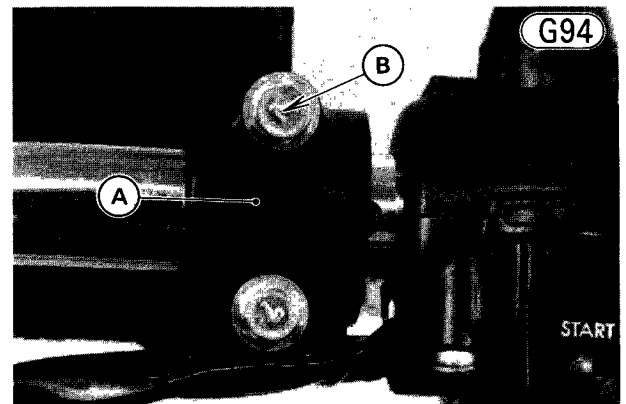

138 DISASSEMBLY—CHASSIS

5. Check and adjust the following items:
 Front brake (Pg. 24).
 Throttle Cable (Pg. 14).
 Clutch (Pg. 17).
 Rear view mirrors

STEERING STEM

Removal:

- Remove the fuel tank (Pg. 43).
- Remove the speedometer cable (Pg. 128).
- Remove the front wheel (Pg. 109).
- Remove the headlight unit (Pg. 129).
- Disconnect all the leads and plugs in the headlight housing.
- Remove the handlebar (Pg. 136).
- Remove the right front fork upper clamp bolt and cable guide, and loosen the left front fork upper clamp bolt.

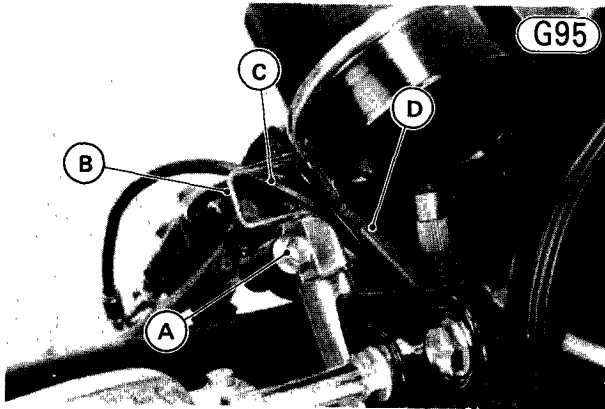

A. Upper Clamp Bolt
 B. Cable Guide
 C. Throttle Cable
 D. Brake Hose

- Disconnect the tachometer cable at the tachometer with pliers.
- Remove the screws (2), and take off the stem base cover.
- Remove the mounting bolts (2) and the 2-way joint.

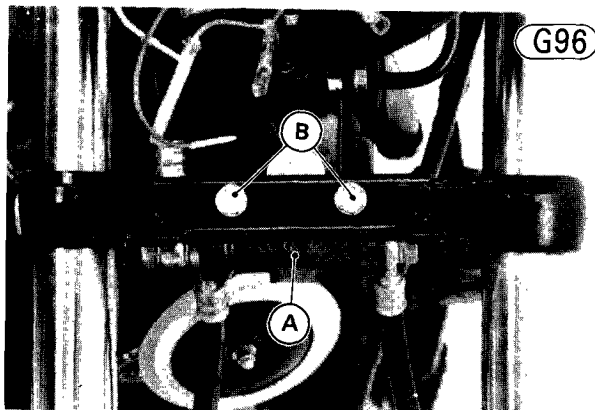

A. 2-way Joint
 B. Mounting Bolts

- Remove the headlight mounting bracket bolts (3), and remove the bracket with the headlight housing. Each

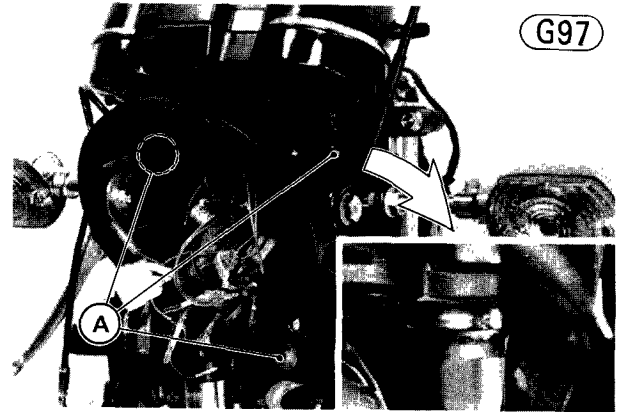

A. Bolts

- Remove the calipers together with the master cylinder, upper brake hose, 2-way joint, and lower brake hoses.
- Loosen the stem head clamp bolt, and then remove the stem head bolt, flat washer, and lockwasher.

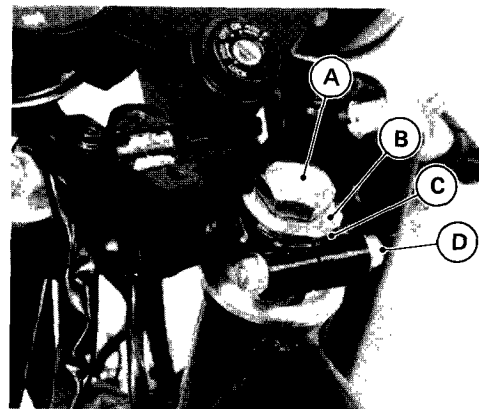

A. Stem Head Bolt
 B. Flat Washer
 C. Lockwasher
 D. Clamp Bolt

- Tap lightly on the bottom of the stem head with a mallet, and then remove the steering stem head together with the meters and ignition switch.

CAUTION Place the stem head so that the correct side of the meters are up. If a meter is left upside down or sideways for any length of time, it will malfunction.

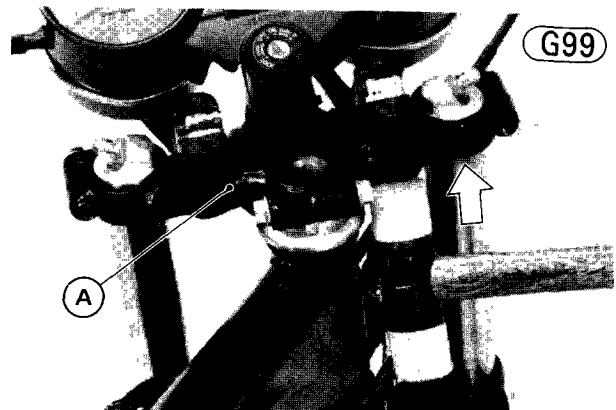

- Remove the front fender bolts and lockwashers (4 ea), and take off the fender.
- Loosen the lower clamp bolts, and pull out each fork leg with a twisting motion.
- Push up on the stem base, and remove the steering stem locknut with the stem nut wrench (special tool); then remove the steering stem and stem base (single unit). As the stem is removed, some of the steel balls will drop out of the lower outer race. Remove the rest. There are 20 steel balls in the lower outer race.

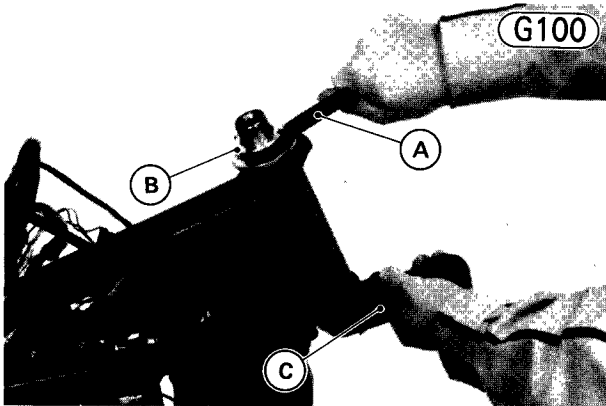

A. Stem Nut Wrench (57001-1100) **C. Stem Base**
B. Stem Locknut

- Remove the steering stem cap, the upper inner race, and the upper steel balls (19).

Installation Notes:

1. Apply grease to the upper and lower outer races in the head pipe so that the steel balls will stick in place during stem insertion. Install the upper steel balls (19) and lower steel balls (20). All upper and lower steel balls are one size.
2. Tightening order and tightening torque for each bolt and nut are shown as follows:
 1. Steering stem locknut: 2.0 kg-m (14.5 ft-lbs)
 2. Front fork upper clamp bolts: 2.0 kg-m (14.5 ft-lbs)
 3. Steering stem head bolt: 4.0 kg-m (29 ft-lbs)
 4. Steering stem head clamp bolt: 1.8 kg-m (13.0 ft-lbs)
 5. Front fork lower clamp bolts: 3.8 kg-m (27 ft-lbs)

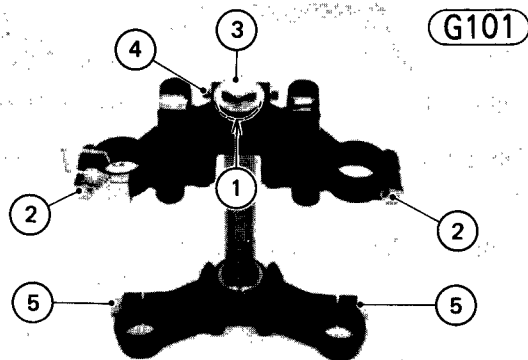

3. Install the front fork legs referring to the front fork "Installation Notes". See Pg. 140.
4. Route the cables and harnesses correctly.
5. Check and adjust the following items:
 - Steering (Pg. 26)
 - Front Brake (Pg. 24)
 - Clutch (Pg. 17)
 - Throttle cable (Pg. 14)
 - Rear view mirrors

Steering Stem, Bearings

G102

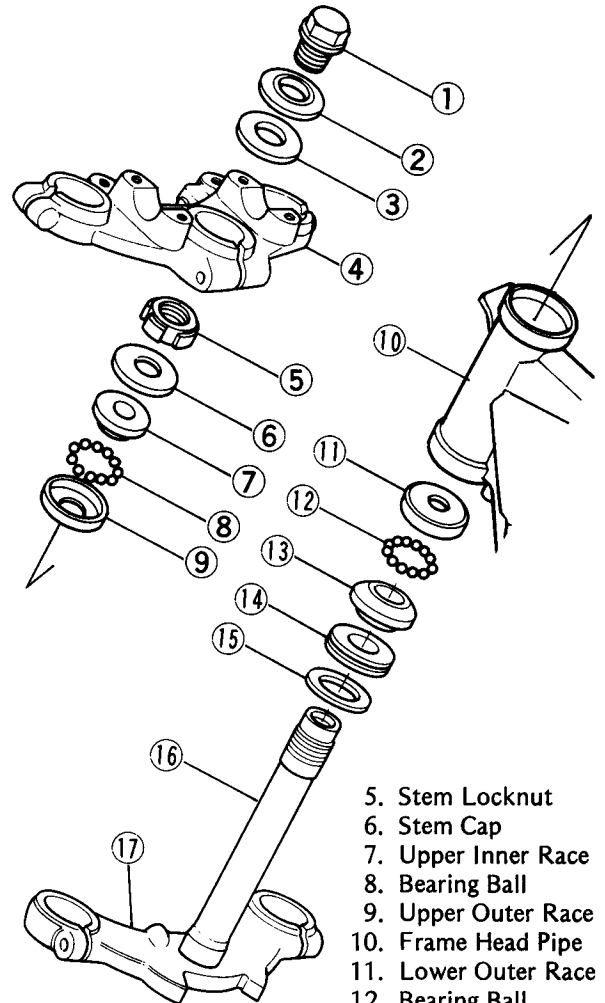

- | | |
|-------------------|----------------------|
| 1. Stem Head Bolt | 5. Stem Locknut |
| 2. Flat Washer | 6. Stem Cap |
| 3. Wave Washer | 7. Upper Inner Race |
| 4. Stem Head | 8. Bearing Ball |
| | 9. Upper Outer Race |
| | 10. Frame Head Pipe |
| | 11. Lower Outer Race |
| | 12. Bearing Ball |
| | 13. Lower Inner Race |
| | 14. Grease Seal |
| | 15. Flat Washer |
| | 16. Steering Stem |
| | 17. Stem Base |

STEERING STEM BEARINGS

Removal:

- Remove the steering stem (Pg. 138).
- To remove the outer races pressed into the head pipe, insert a bar into the head pipe, and hammer evenly around the circumference of the opposite race to drive

140 DISASSEMBLY—CHASSIS

G103

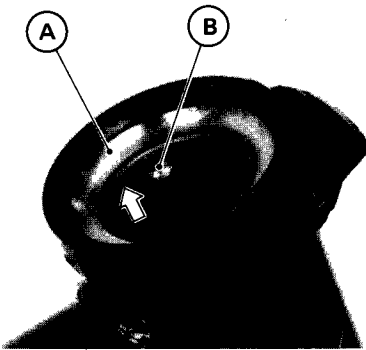

A. Outer Race B. Bar

- Remove the grease seal under the lower inner race. Be careful not to damage the grease seal during removal.
- Remove the lower inner race, which is pressed onto the steering stem, with the stem bearing puller and adapter (special tools).

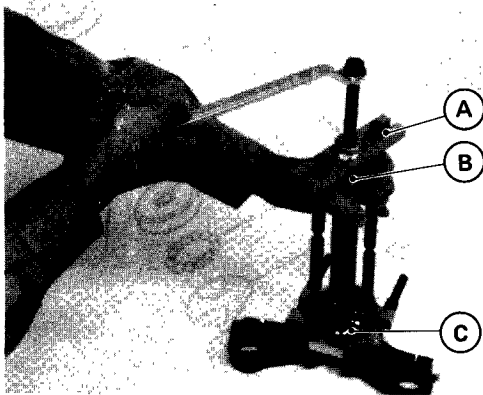

A. Bearing Puller (57001-135) B. Adapter (57001-136) C. Lower Inner Race

- Remove the washer from the steering stem.

Installation Notes:

1. Apply oil to the outer races, and then drive them into the head pipe using the stem cup driver and the bearing driver holder (special tools). Be sure to press them until they stop at the stepped portion in the head pipe.

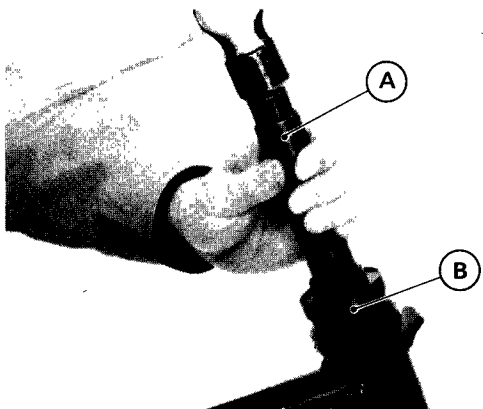

A. Bearing Driver Holder (57001-139)

2. Apply oil to the lower inner race, and then drive it onto the steering stem using the stem bearing driver (special tool). Be sure to press it until it stops at the stem base.

G106

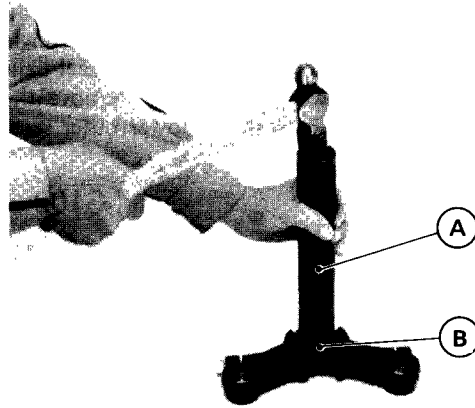

A. Stem Bearing Driver (57001-137) B. Inner Race

FRONT FORK

Removal (each fork leg):

- Remove the mounting bolts, take off the only caliper on the fork leg to be removed, and rest the caliper on some kind of stand so that it does not dangle.
- Remove the front wheel (Pg. 109).
- Remove the bolts and lockwashers (4) that hold the front fender to the left fork leg, and remove the fender.
- If the fork leg is to be disassembled after removed, loosen the top plug now.
- Loosen the upper and lower front fork clamp bolts.

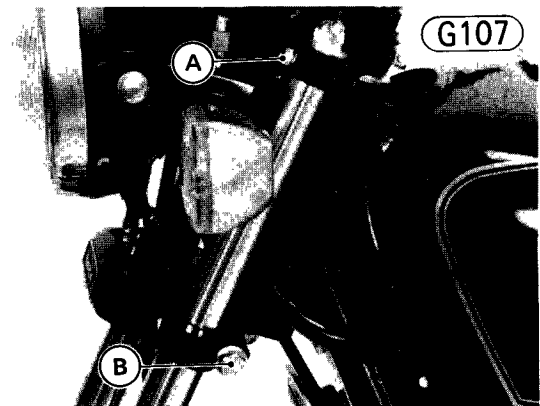

A. Upper Clamp Bolt B. Lower Clamp Bolt

- With a twisting motion, work the fork leg down and out.

Installation Notes (each fork leg):

1. If the fork leg was disassembled, check the fork oil level (Pg. 213). And apply a non-permanent locking agent to the thread of the air valve and tighten the valve to 1.2 kg-m (104 in-lbs) of torque. Then inject

- Slide the fork leg up through the lower and upper clamps, tighten the upper clamp bolt to 2.0 kg-m (14.5 ft-lbs) of torque, and lower clamp bolt to 3.8 kg-m (27 ft-lbs) of torque. For KZ750-E, the upper end of the front fork inner tube is even with the upper surface of the stem head. For KZ750-H, the upper surface of the top plug flange is even with the upper surface of the stem head.

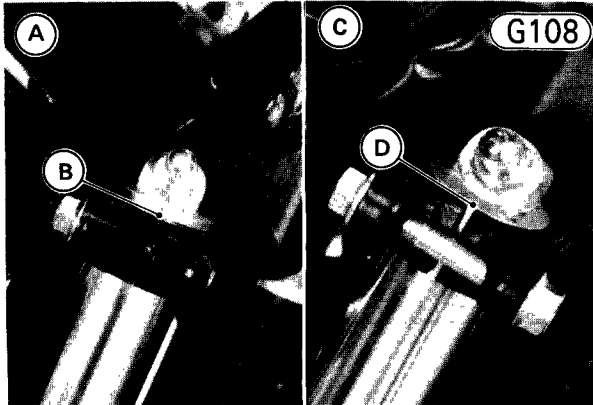

A. KZ750-E
 B. Inner Tube Upper End
 C. KZ750-H
 D. Top Plug Flange Upper End

- If the top plug was loosened during removal, tighten it to 2.3 kg-m (16.5 ft-lbs) of torque.
- Check the front brake (Pg. 24).

Disassembly:

- Remove the air valve (20) and its O ring (21).
- Remove the top plug (22), O ring (23), and spring (26).
- Pour the oil into a suitable container, pumping as necessary to empty out all the oil.
- Stop the cylinder (2) from turning by using the front fork cylinder holder handle and holder adapter (special tools). Unscrew the Allen bolt (15) and gasket (16) from the bottom of the outer tube (9) or (44), and then separate the inner tube from the outer tube by pulling it out.

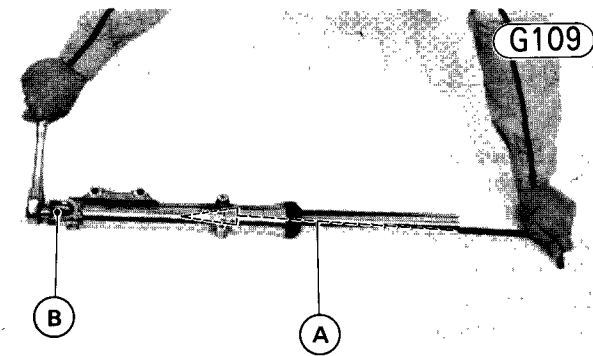

A. Front Fork Cylinder Holder Handle and Adapter (57001-183, 57001-1011)

- Slide or push the cylinder (2) and its spring (4) out the top of the inner tube.
- Remove the dust seal (6) off the outer tube (9).
- Remove the cylinder base (5).
- Remove the retainer (7) from the outer tube with a sharp hook, and pull out the oil seal (8). It may be necessary to heat the outer tube around the oil seal before pulling it out.

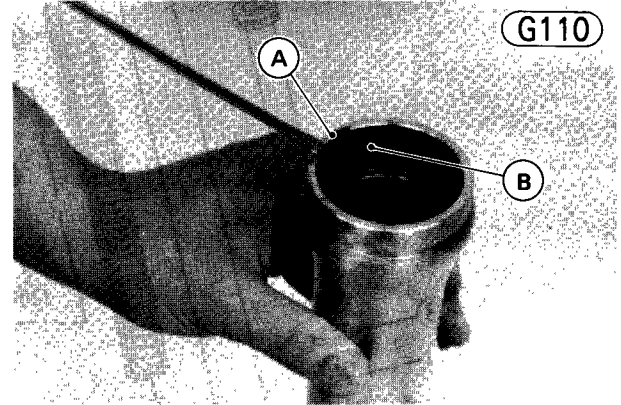

A. Retainer
 B. Oil Seal

Assembly Notes:

- Apply liquid gasket to both sides of the gasket (16), apply a non-permanent locking agent to the Allen bolt, and tighten it using the front fork cylinder holder handle and holder adapter (special tools) to stop the cylinder from turning. The torque for the Allen bolt is 2.3 kg-m (16.5 ft-lbs).
- Replace the oil seal with a new one, apply oil to the outside, and install it with the front fork oil seal driver (special tool).

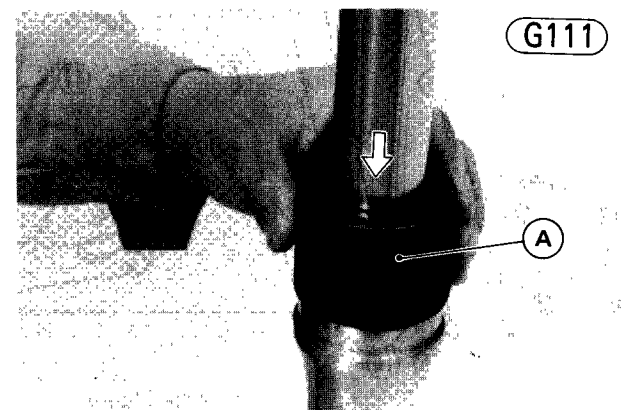

A. Front Fork Oil Seal Driver (57001-141)

- If the drain screw is removed, check the gasket (10) for damage. Replace the damaged gasket with a new one. Before installing the drain screw, apply a liquid gasket to the threads of the screw, and tighten the screw securely.
- Pour in the type and amount of fork oil specified in Table J17, and adjust the oil level (Pg. 213).
- Check the O rings (21) and (23) for damage. Replace

142 DISASSEMBLY-CHASSIS

Front Fork

G112

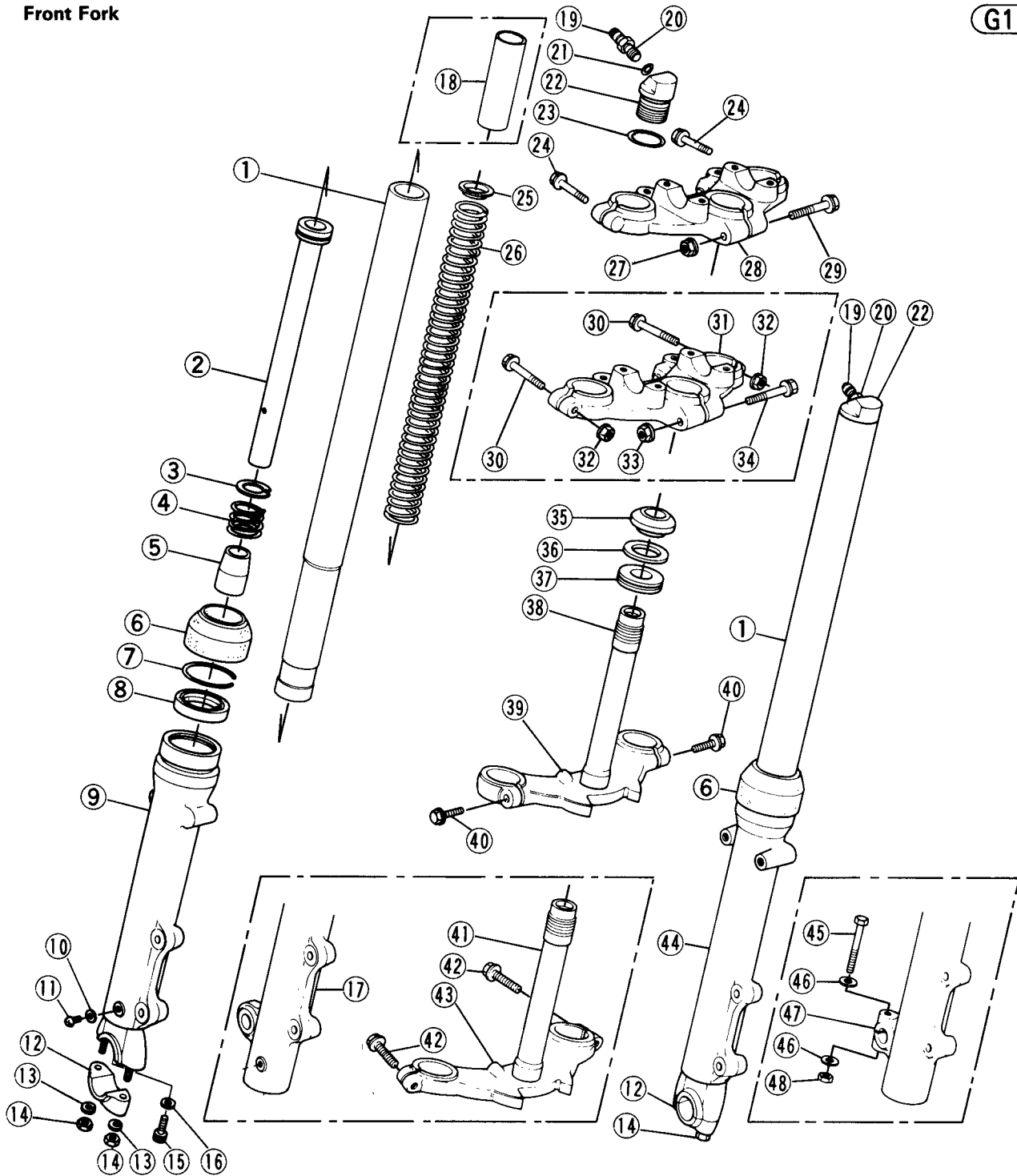

*:KZ750-H only

- 1. Inner Tube
- 2. Piston and Cylinder Unit
- 3. Piston Ring
- 4. Spring
- 5. Cylinder Base
- 6. Dust Seal
- 7. Retainer
- 8. Oil Seal
- 9. Left Outer Tube
- 10. Gasket
- 11. Gasket
- 12. Axle Clamp
- 13. Lockwasher
- 14. Clamp Nut
- 15. Allen Bolt
- 16. Gasket

- 12. Axle Clamp
- 13. Lockwasher
- 14. Clamp Nut
- 15. Allen Bolt
- 16. Gasket
- *17. Left Outer Tube
- *18. Collar
- 19. Cap
- 20. Air Valve
- 21. O Ring
- 22. Top Plug
- 23. O Ring
- 25. Spring Seat
- 26. Spring
- 27. Nut
- 28. Stem Head
- 29. Clamp Bolt
- *30. Upper Clamp Bolt
- *31. Stem Head
- *32. Nut
- *33. Nut
- *34. Clamp Bolt
- 35. Lower Inner Race
- 36. Grease Seal
- 38. Steering Stem
- 39. Stem Base
- 40. Lower Clamp Bolt
- *41. Steering Stem
- *42. Lower Clamp Bolt
- *43. Stem Base
- 44. Right Outer Tube
- *45. Clamp Bolt
- *46. Flat Washer
- *47. Right Outer Tube
- *48. Nut

- 25. Spring Seat
- 26. Spring
- 27. Nut
- 28. Stem Head
- 29. Clamp Bolt
- *30. Upper Clamp Bolt
- *31. Stem Head
- *32. Nut
- *33. Nut
- *34. Clamp Bolt
- 35. Lower Inner Race
- 36. Grease Seal
- 38. Steering Stem
- 39. Stem Base
- 40. Lower Clamp Bolt
- *41. Steering Stem
- *42. Lower Clamp Bolt
- *43. Stem Base
- 44. Right Outer Tube
- *45. Clamp Bolt
- *46. Flat Washer
- *47. Right Outer Tube
- *48. Nut

- 38. Steering Stem
- 39. Stem Base
- 40. Lower Clamp Bolt
- *41. Steering Stem
- *42. Lower Clamp Bolt
- *43. Stem Base
- 44. Right Outer Tube
- *45. Clamp Bolt
- *46. Flat Washer
- *47. Right Outer Tube
- *48. Nut

6. Apply a non-permanent locking agent to the threads of the air valve, and tighten the valve to 1.2 kg-m (104 in-lbs) of torque. Inject air through the air valve (Pg. 22) after installing the fork leg.

- Remove the cap nut, lockwasher, and flat washer. To remove the left shock absorber, also remove the grab rail.
- Lift up on the rear wheel as necessary to avoid damaging the shock absorber bolt threads, and remove the shock absorber bolt and lockwasher.
- Pull off the rear shock absorber.

Installation Note:

- Tighten the shock absorber bolt and nut to 3.0 kg-m (22 ft-lbs) of torque. The arrow for the damper adjusting wheel must point out.

REAR SHOCK ABSORBERS

Removal (each side):

NOTE: For KZ750-H, remove the grab rail as follows:

- Remove the grab rail mounting bolts and lockwashers (2 ea), and remove the rear shock absorber upper mounting cap nuts, lockwashers, and flat washers (2 ea).

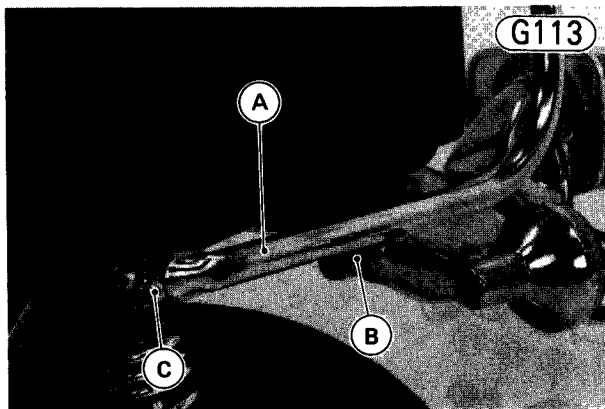

A. Grab Rail B. Mounting Bolt C. Cap Nut

- Pull the grab rail toward the rear.
- Set the motorcycle up on its center stand.
- To remove the left shock absorber, remove the grab rail mounting bolt, nut, and flat washer.

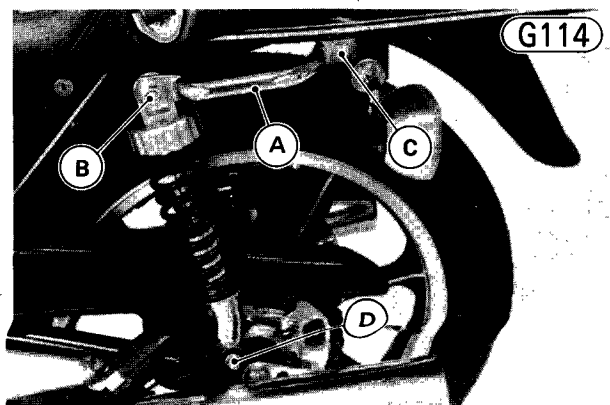

A. Grab Rail C. Grab Rail Mounting Bolt

SWING ARM

Removal:

- Set the motorcycle up on its center stand.
- Remove the rear wheel (Pg. 110).
- Pull the rear brake hose out of the guides on the swing arm, remove the torque link rear bolt, and rest the rear caliper on some kind of stand.
- Remove the drive chain cover. For KZ750-E, it has the mounting screws and flat washers (2 ea). For KZ750-H it has the mounting bolts, lockwashers, and flat washer (3 ea).

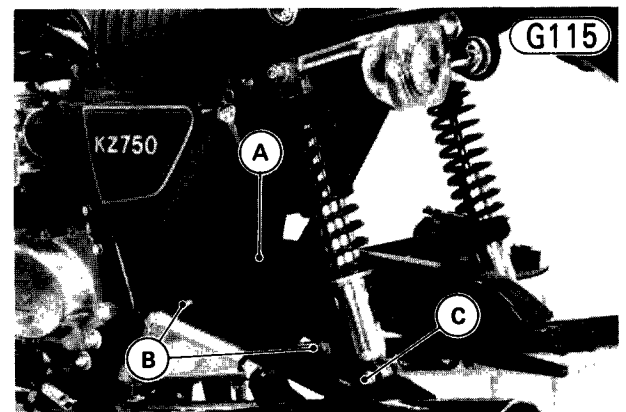

A. Chain Cover C. Shock Absorber Mounting Bolt
B. Mounting Screws

- Remove the mounting bolt from each shock absorber bottom. A lockwasher comes off with the bolt.
- Remove the pivot shaft nut and pull out the pivot

144 DISASSEMBLY-CHASSIS

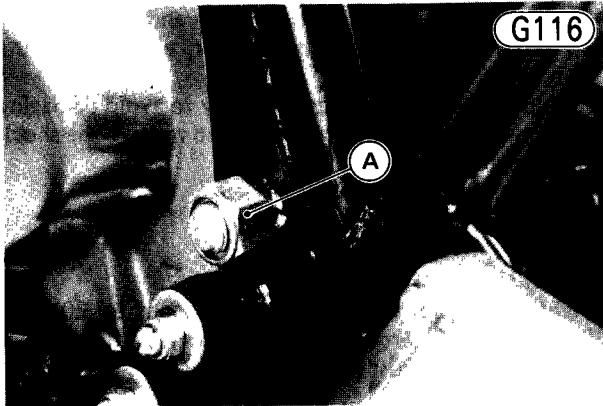

A. Pivot Shaft Nut

- Pull back the swing arm. A cap on each side of the pivot will also drop off.

Installation Notes:

1. Put the left side of the swing arm through the drive chain loop.

2. Install the pivot shaft nut, and tighten the nut to 10.0 kg-m (72 ft-lbs) of torque.
3. Move the swing arm up and down to check for abnormal friction.

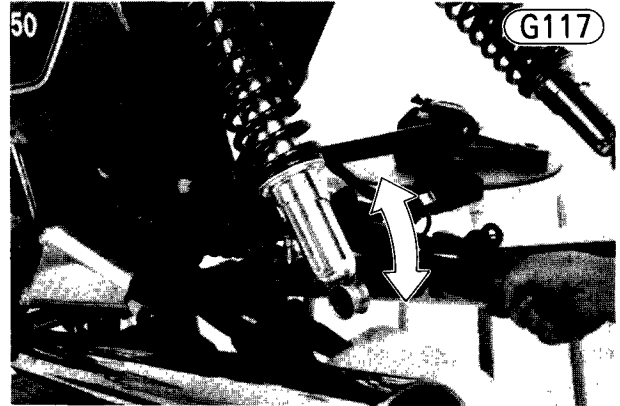

4. Install the rear shock absorber bolts and lockwashers, tighten each bolt to 3.0 kg-m (22 ft-lbs) of torque.
5. Adjust the drive chain (Pg. 23) after installation.

Swing Arm

G118

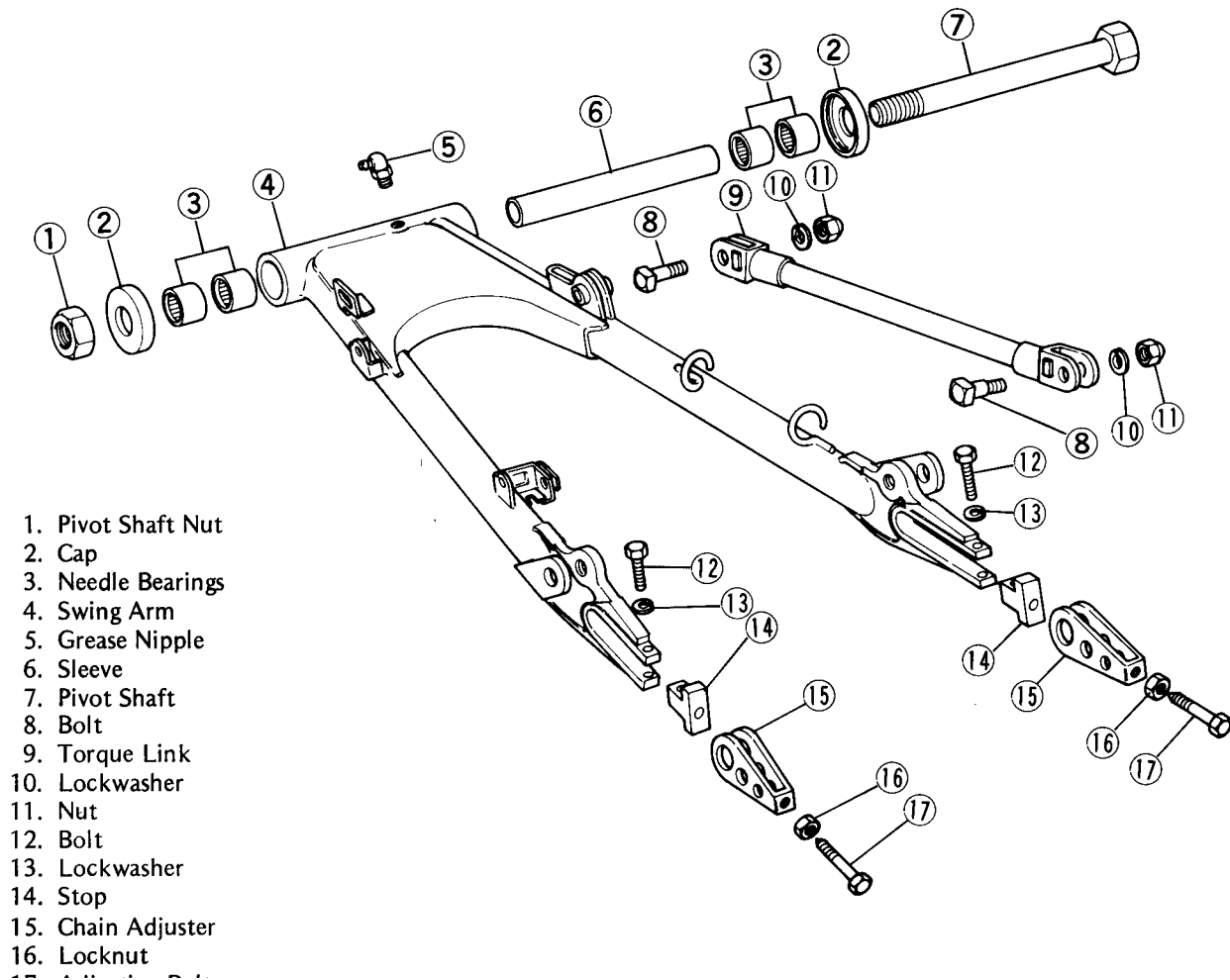

1. Pivot Shaft Nut
2. Cap
3. Needle Bearings
4. Swing Arm
5. Grease Nipple
6. Sleeve
7. Pivot Shaft
8. Bolt
9. Torque Link
10. Lockwasher
11. Nut
12. Bolt
13. Lockwasher
14. Stop
15. Chain Adjuster
16. Locknut
17. Locknut

Disassembly:

NOTE: As the swing arm needle bearings will be damaged upon removal, be sure to have new ones on hand prior to disassembly.

- Remove the caps (2) off both end.
- Take out the torque link nut (11), lockwasher (10), and bolt (8), and then remove the torque link (9) from the swing arm (4).
- Pull out the swing arm sleeve (6).
- Insert a bar into one side, hammering on them lightly to knock out the needle bearings (3) on the opposite side.

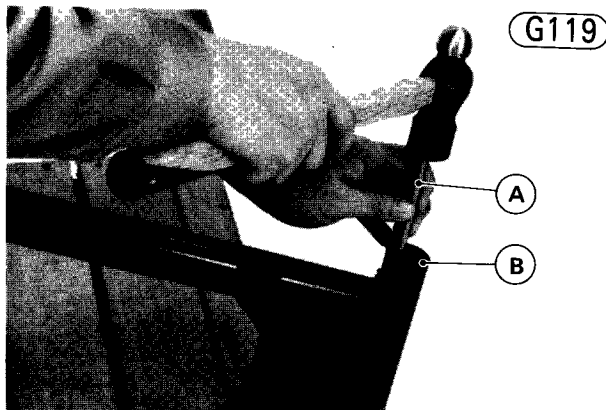

A. Bar B. Needle Bearing

- Use the bar again to knock out the other bearings.

Assembly Notes:

1. Inspect the swing arm sleeve (Pg. 215), and replace it with a new one if it has worn past the service limit or is damaged. Also, replace all needle bearings whenever the sleeve is replaced.
2. Replace the needle bearings with new ones if any one has been damaged or removed. Apply oil to the outside surface of the bearings before installing them with a press.
3. Install the torque link so that the welded side faces in. After installation tighten the torque link nut to 3.0 kg-m (22 ft-lbs) of torque.

G120

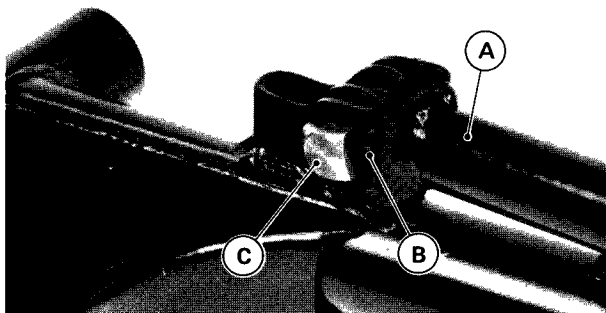

A. Torque Link C. Torque Link Bolt

4. Adjust the drive chain (Pg. 23) after installing the swing arm.

DRIVE CHAIN**Removal:**

WARNING The chain must not be cut for installation, as this may result in subsequent chain failure and loss of control.

- Remove the engine sprocket (Pg. 66).
- Remove the rear wheel (Pg. 110).
- Remove the swing arm (Pg. 143) and take off the chain.

Installation Note:

- Adjust the drive chain (Pg. 23) after installation.

Maintenance—Engine

Table of Contents

AIR CLEANER	148
FUEL TANK, FUEL TAP	149
CARBURETOR	150
Starter System	151
Pilot System	152
Main System	154
Float System	155
CAMSHAFT	157
CAMSHAFT CHAIN, GUIDE, TENSIONER	159
CYLINDER HEAD, VALVE	160
Cylinder Head	160
Valve, Valve Guide, Valve Seat	161
Valve Spring	165
Oil Seal	166
KAWASAKI CLEAN AIR SYSTEM	166
Air Suction Valve	166
Vacuum Switch Valve	167
CYLINDER BLOCK, PISTON	168
CRANKSHAFT, CONNECTING ROD	172
SECONDARY SHAFT	176
PRIMARY CHAIN	177
CLUTCH	177
TRANSMISSION	180
Shift Mechanism	180
Neutral Locator	183
Overshift Limiter	183
ENGINE LUBRICATION	186
Oil Pressure Switch, Relief Valve	186
Engine Oil Pump	188
Oil Filter	189
Oil Breather	190
BALL BEARING, NEEDLE BEARING	190
OIL SEAL	190
MUFFLER	190

AIR CLEANER

A properly maintained air cleaner ensures that only clean, filtered air is supplied through the carburetor to the engine. If the air is supplied directly without filtering, dirt and dust from the air will clog carburetor passages causing the engine to run poorly. The dust that enters the engine will also act like grinding compound, wearing down the cylinders, pistons, and rings. If the air cleaner element is damaged, the result will be the same as if no element were used.

An air cleaner element clogged with dirt chokes the air supply to the engine, resulting in an overly rich fuel/air mixture and inefficient combustion. This in turn causes overheating from carbon build-up, and reduced engine power.

Cleaning and replacement

The air cleaner element must be cleaned periodically (Pg. 10). In extremely dry, dusty areas, the element will need to be cleaned more often. After riding through rain or on muddy roads, the element should be cleaned immediately.

Remove the air cleaner element (Pg. 45). Clean it in a bath of a high flash-point solvent, and then dry it from the inside using compressed air. Since this is a dry-type element, do not use kerosene or any fluid which would leave the element oily.

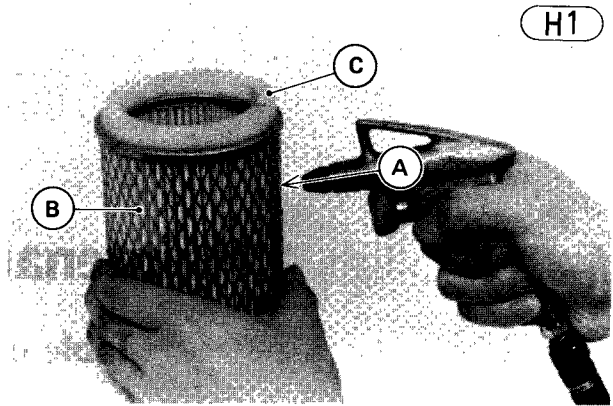

A. Compressed Air **C. Sponge Gasket**
B. Air Cleaner Element

WARNING Clean the element in a well-ventilated area, and take care that there is no spark or flame anywhere near the working area. Because of the danger of highly flammable liquids, do not use gasoline or low flash-point solvents to clean the element.

If the sponge gaskets on the sides of the element come loose, stick them back on with an adhesive sealant. If the sponge or the element is damaged or holed, replace the element.

Since repeated cleaning opens the pores of the element, replace it with a new one in accordance with the Periodic Maintenance Chart (Pg. 10). Also, if there is a break in the element material or any other damage to the element, replace the element with a new one.

Air Cleaner

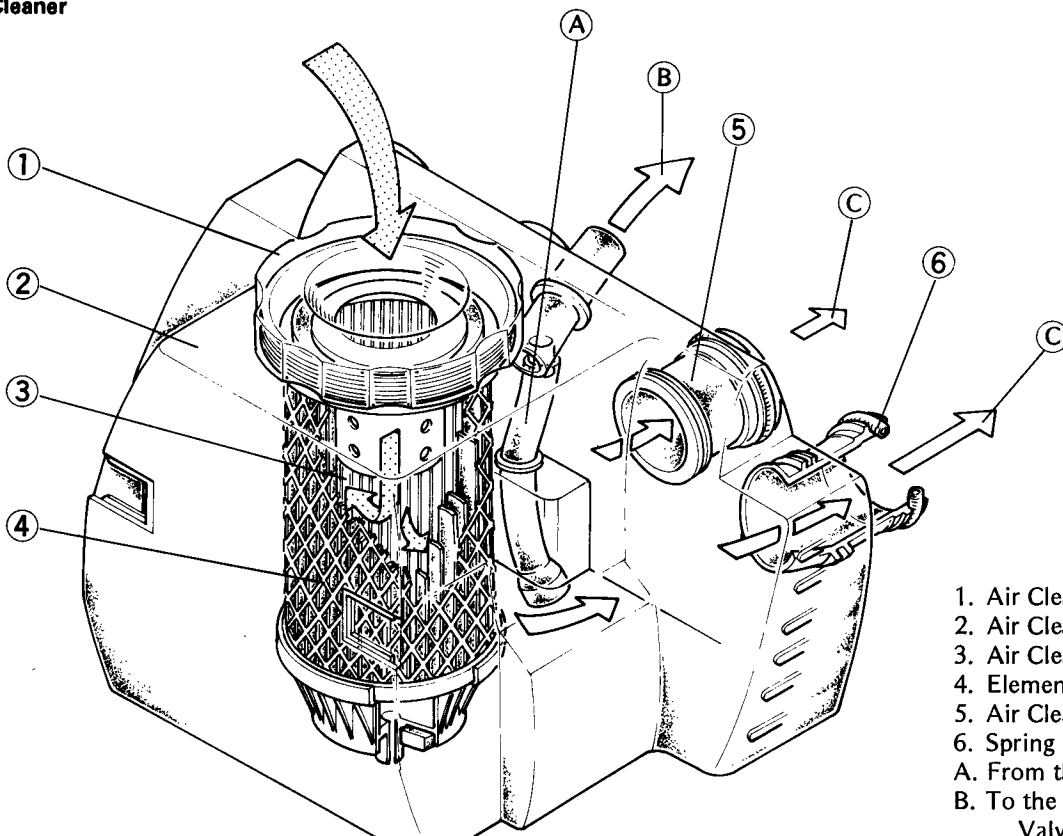

1. Air Cleaner Cap
2. Air Cleaner Housing
3. Air Cleaner Element
4. Element Frame
5. Air Cleaner Duct
6. Spring Band
A. From the Breather
B. To the Vacuum Switch Valve
C.

H1

H2

FUEL TANK, FUEL TAP

The fuel tank capacity for KZ750-E is 17.3 ℓ, 1.7 ℓ of which forms the reserve supply. For KZ750-H, the tank capacity is 12.4 ℓ, 1.8 ℓ of which forms the reserve supply. A cap is attached to the top of the tank, and a fuel tap to the bottom. An air vent is provided in the cap to prevent an air lock, which would hinder fuel flow to the carburetors.

Fuel tap construction is shown in Fig. H3. The fuel tap is an automatic type which shuts off the fuel supply when the engine is stopped in the **ON** or **RES** position. The fuel tap has three positions: **ON**, **RES** (reserve), and **PRI** (prime). With the tap in the "On" position, fuel flows through the tap by way of the main pipe until only the reserve supply is left in the tank; with the tap in the "Reserve" position, fuel flows through the tap from the bottom of the tank. The "Pri" position bypasses the automatic control and is useful for priming the engine after running out of gas, or for completely draining the tank. The fuel tap contains a filter to filter out dirt.

Fuel Tap

H3

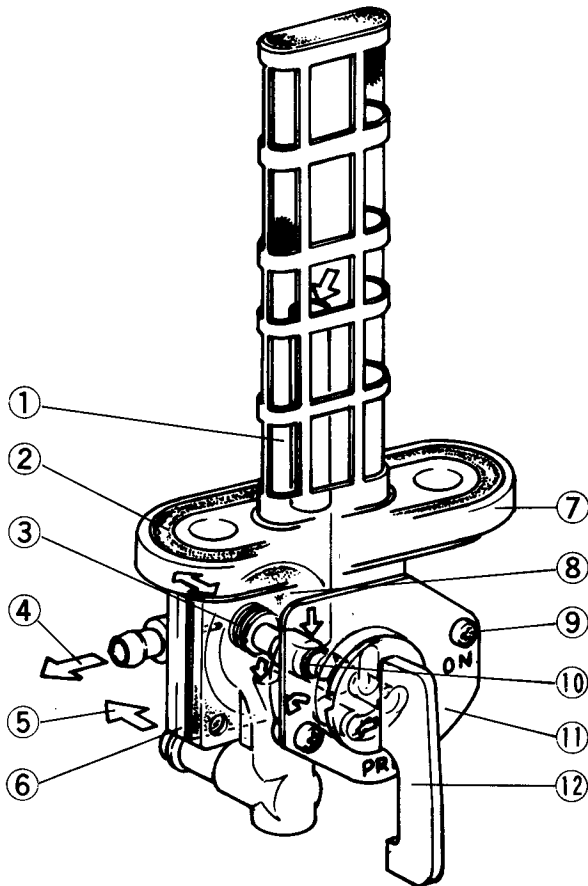

- | | |
|-----------|-------------------|
| 1. Filter | 7. Body |
| 2. O Ring | 8. Diaphragm |
| 3. Spring | 9. Screw |
| 4. Vacuum | 10. O Ring |
| 5. Fuel | 11. Holding Plate |

The automatic valve in the fuel tap operates as follows: When the engine is running, negative pressure (vacuum) is created at the carburetor due to engine intake. This engine intake vacuum is transmitted to the diaphragm vacuum chamber in the fuel tap through the vacuum hose and the check valve. The vacuum pulls the diaphragm ⑧ against its spring pressure, and the O ring ⑩ on the diaphragm assembly ⑧ is pulled out of its seat, permitting fuel to flow between the O ring and seat. When the engine stops and vacuum is lost, air enters the diaphragm vacuum chamber through the vacuum hose, bringing chamber pressure back up to atmospheric and allowing the diaphragm spring ③ to push the diaphragm back into place and hold the O ring against the seat.

The check valve in the diaphragm cover keeps the pressure in the diaphragm vacuum chamber negative in spite of the pulsation of the intake vacuum while the engine is running so that fuel flows smoothly.

Inspection and cleaning

If fuel leaks from the tank cap or from around the fuel tap, the cap gasket or tap O ring may be damaged. Visually inspect these parts, and replace them if necessary.

Examine the air vent in the tank cap to see if it is obstructed. Use compressed air to clear an obstructed vent.

Any water in the fuel tank and the carburetors can be drained through the drain plugs (Pg. 19). If water cannot be drained completely by loosening the drain plugs, remove the fuel tap (Pg. 43), and flush out the tank with a high flash-point solvent. For thorough cleaning of the carburetors, remove and disassemble the carburetors (Pg. 45).

If there is any doubt about the condition of the fuel tap, remove and disassemble the fuel tap (Pg. 44), and inspect the parts. Especially examine the diaphragm assembly. Make sure the O ring and its seat are clean and undamaged; if the O ring is prevented from seating properly or if it is damaged, fuel flow will not stop when the engine is stopped, and may overflow from the carburetors. Visually inspect the diaphragm. If there is any tear or other damage, the diaphragm assembly should be replaced.

H4

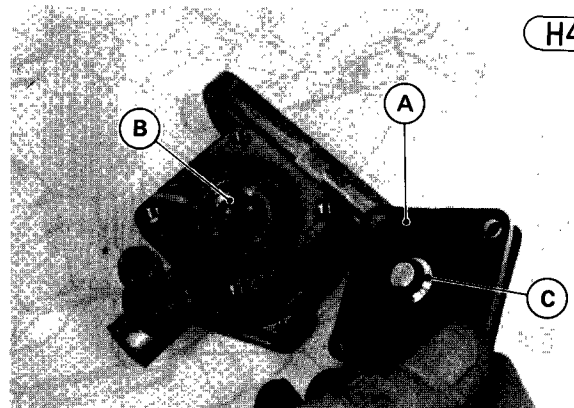

A. Diaphragm Assembly

C. "O" Ring

150 MAINTENANCE—ENGINE

Clean the air and fuel passages by lightly applying compressed air to the passage openings.

CAUTION Do not use wire for cleaning as this could damage the check valve, O ring seat, and diaphragm mating surfaces.

CARBURETOR

The carburetors perform the function of mixing the fuel and air in the proportions necessary for good engine performance at varying speeds and loads. In order for them to function satisfactorily, they must be properly adjusted and maintained. The throttle cable adjustment, idling adjustment, and synchronizing adjustment are covered in the Adjustment Section. The discussion here concerns the fundamentals of carburetor operation, fuel level adjustment, and cleaning and replacement of carburetor parts.

A linkage mechanism opens each carburetor butterfly valve the same amount in response to throttle grip movement so that the carburetors operate in unison. As the throttle grip is turned counterclockwise, the throttle

accelerator cable turns the carburetor pulley. Through the linkage mechanism the pulley opens the butterfly valves. As the throttle grip is turned clockwise or is released, the linkage mechanism return spring closes the butterfly valves.

One of the basic principles in carburetor operation is that the pressure exerted by a moving body of air is less than atmospheric pressure. As the engine draws air in through the carburetor bore, the air pressure in the carburetor bore is less than the air pressure in the float chamber, which is vented to the atmosphere. This difference in air pressure forces fuel up through the passages into the carburetor bore, where it is atomized by the high-speed air flowing into the engine.

Another important principle is the Venturi Principle, which states that when an air passage narrows, moving air flows faster, exerting even less pressure. For example, at low speeds (0~¼ throttle) the vacuum piston is at its lowest position, forming what is called the "primary venturi". Since the engine intake requires less air at lower engine speeds, there would not be enough air flow speed for sufficient fuel to be forced up through the jets unless the passage (carburetor bore) above the jets is constricted. The low position of the vacuum piston constricts this passage so that there will be sufficient

Carburetor Constructions

H5

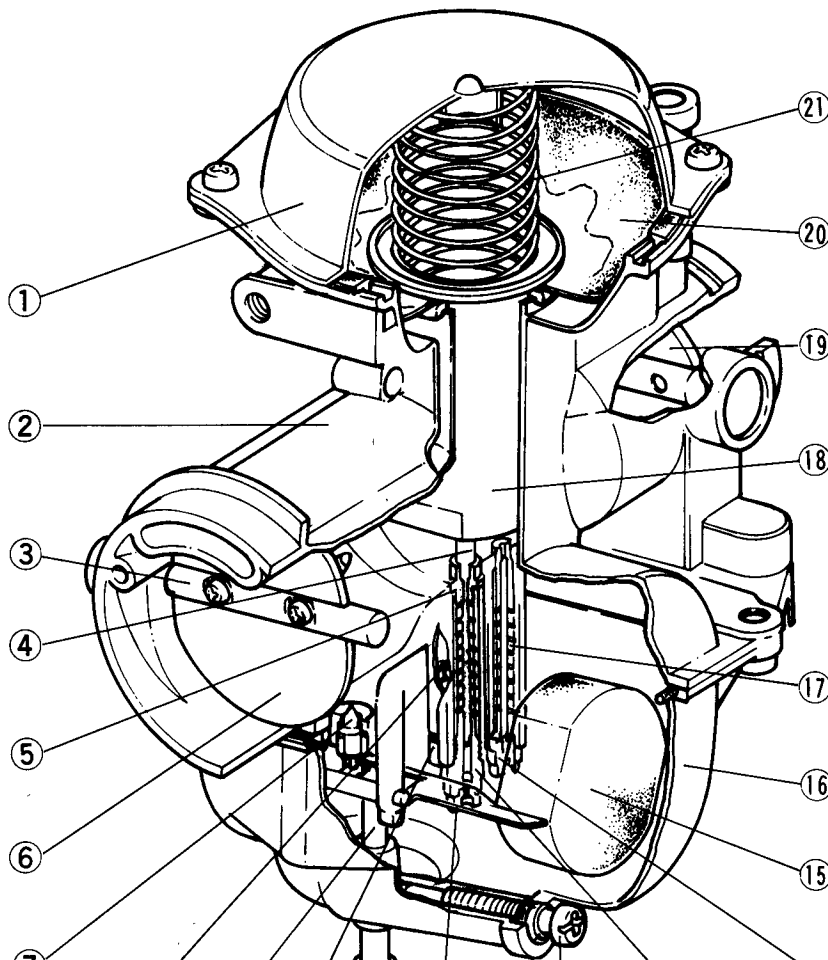

1. Upper Chamber Cover
2. Carburetor Body
3. Choke Shaft
4. Jet Needle
5. Needle Jet
6. Choke Valve
7. Float Valve Needle
8. Pilot Jet
9. Overflow Pipe
10. Plastic Plug
11. Secondary Main Jet
12. Drain Screw
13. Needle Jet Holder
14. Primary Main Jet
15. Float
16. Float Chamber
17. Bleed Pipe
18. Vacuum Piston
19. Throttle Shaft
20. Diaphragm

FUEL TANK, FUEL TAP

The fuel tank capacity for KZ750-E is 17.3 ℓ, 1.7 ℓ of which forms the reserve supply. For KZ750-H, the tank capacity is 12.4 ℓ, 1.8 ℓ of which forms the reserve supply. A cap is attached to the top of the tank, and a fuel tap to the bottom. An air vent is provided in the cap to prevent an air lock, which would hinder fuel flow to the carburetors.

Fuel tap construction is shown in Fig. H3. The fuel tap is an automatic type which shuts off the fuel supply when the engine is stopped in the **ON** or **RES** position. The fuel tap has three positions: **ON**, **RES** (reserve), and **PRI** (prime). With the tap in the "On" position, fuel flows through the tap by way of the main pipe until only the reserve supply is left in the tank; with the tap in the "Reserve" position, fuel flows through the tap from the bottom of the tank. The "Pri" position bypasses the automatic control and is useful for priming the engine after running out of gas, or for completely draining the tank. The fuel tap contains a filter to filter out dirt.

Fuel Tap

H3

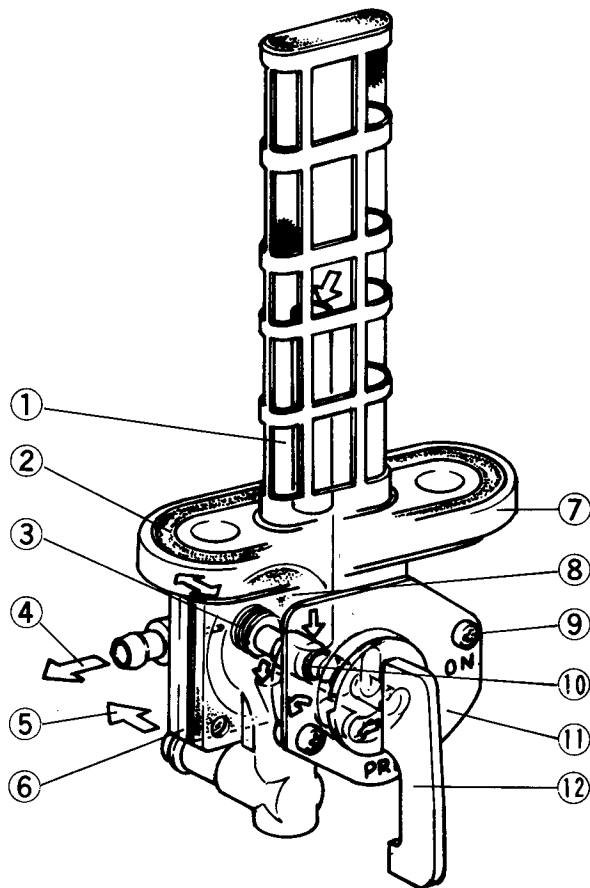

- | | |
|-----------|-------------------|
| 1. Filter | 7. Body |
| 2. O Ring | 8. Diaphragm |
| 3. Spring | 9. Screw |
| 4. Vacuum | 10. O Ring |
| 5. Fuel | 11. Holding Plate |

The automatic valve in the fuel tap operates as follows: When the engine is running, negative pressure (vacuum) is created at the carburetor due to engine intake. This engine intake vacuum is transmitted to the diaphragm vacuum chamber in the fuel tap through the vacuum hose and the check valve. The vacuum pulls the diaphragm (8) against its spring pressure, and the O ring (10) on the diaphragm assembly (8) is pulled out of its seat, permitting fuel to flow between the O ring and seat. When the engine stops and vacuum is lost, air enters the diaphragm vacuum chamber through the vacuum hose, bringing chamber pressure back up to atmospheric and allowing the diaphragm spring (3) to push the diaphragm back into place and hold the O ring against the seat.

The check valve in the diaphragm cover keeps the pressure in the diaphragm vacuum chamber negative in spite of the pulsation of the intake vacuum while the engine is running so that fuel flows smoothly.

Inspection and cleaning

If fuel leaks from the tank cap or from around the fuel tap, the cap gasket or tap O ring may be damaged. Visually inspect these parts, and replace them if necessary.

Examine the air vent in the tank cap to see if it is obstructed. Use compressed air to clear an obstructed vent.

Any water in the fuel tank and the carburetors can be drained through the drain plugs (Pg. 19). If water cannot be drained completely by loosening the drain plugs, remove the fuel tap (Pg. 43), and flush out the tank with a high flash-point solvent. For thorough cleaning of the carburetors, remove and disassemble the carburetors (Pg. 45).

If there is any doubt about the condition of the fuel tap, remove and disassemble the fuel tap (Pg. 44), and inspect the parts. Especially examine the diaphragm assembly. Make sure the O ring and its seat are clean and undamaged; if the O ring is prevented from seating properly or if it is damaged, fuel flow will not stop when the engine is stopped, and may overflow from the carburetors. Visually inspect the diaphragm. If there is any tear or other damage, the diaphragm assembly should be replaced.

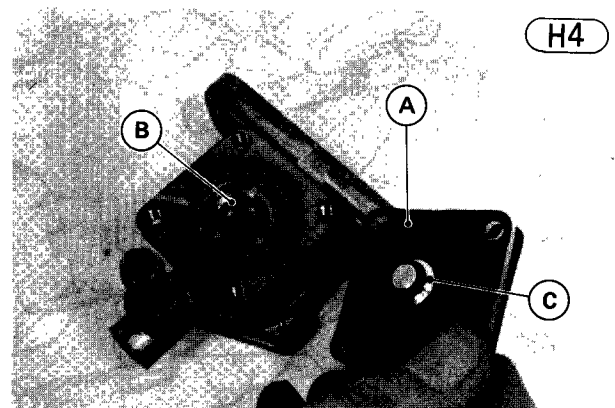

A. Diaphragm Assembly

C. "O" Ring

H4

air flow speed for pressure difference to force the necessary amount of fuel up through the jet.

The amount of fuel passing through a jet depends both on the size of the jet and on the speed of the air flow over the jet. The speed of this air flow is in turn determined both by the engine rpm and by the dimensions of the passage (varied with the vacuum piston) various dimensions of the air passages, and the engine just above the jet. The size of the jet openings, the various dimensions of the air passages, and the engine rpm are correlated through carburetor design so that, when properly adjusted, the carburetor meters (measures) the fuel and air in the correct proportions at different throttle openings.

The carburetor specifications (Table H4) have been chosen for best all around performance.

Carburetor trouble can be caused by dirt, wear, maladjustment, or improper fuel level in the float chamber. A dirty or damaged air cleaner can also alter the fuel-to-air ratio.

Table H1 Mixture Trouble Symptoms

Poor running
Overheating
Exhaust smokes excessively

The following explanation of the functioning and maintenance of the carburetors covers the four main systems for fuel regulation and supply.

Table H2 Carburetor Systems

System	Function
Starter System	Supplies the necessary rich mixture for starting a cold engine.
Pilot System	Supplies fuel at idling and low speeds.
Main System	Supplies fuel at medium and high speeds.
Float System	Maintains the fuel at a constant level in the float chamber.

- CAUTION** 1. Remove the diaphragm and float before cleaning the carburetor with compressed air, or they will be damaged.
2. Remove as many rubber or plastic parts from the carburetors (Table H3) as possible before cleaning the carburetors with a cleaning solution. This will prevent damage or deterioration of the parts.

Table H4 Carburetor Specifications

Type	Jet Needle	Main Jet		Air Jet			Pilot Jet	Pilot Screw	Fuel Level (mm)	
		Primary	Secondary	Pilot	Primary Main	Secondary Main			Design	Service
CV34 ⓪ CV34-30	N01A	#62	#125	#110	#130	#60	#35	2 turns out ⓪ (—)	36.5 ± 1	4.0 ± 1

3. The carburetor body has plastic parts (Table H3) that cannot be removed. DO NOT use a strong carburetor cleaning solution which could attack these parts; instead, use a mild cleaning solution safe for plastic parts.
4. Do not use wire for cleaning as this could damage the jets.

Table H3 Carburetor Rubber Parts and Plastic Parts

Parts	Quantity
Butterfly Valve Shaft Washers	6
Cable Bracket Washers	4
Choke Valve Linkage Dust Covers	2
Drain Screws	4
Fast Idle Cam Washers	2
Floats	4
Float Bowl O Rings	4
Fuel Hose	1
Idle Adjusting Screw	1
Overflow Tubes	4
Pilot Screw O Rings	4
Pilot Jet Plugs	4
Pilot jet Plug O Rings	4
Vacuum Gauge Fitting Cap	1
Vacuum Hose	1
Vacuum Piston and Diagram Assemblies	4
2-way Joint O Rings	4
3-way Joint	1
3-way Joint O Rings	4

Starter System

Fig. H6 shows the starter system, which includes the choke lever, choke valve ①, choke link spring, idling cam, and idling link.

The starter system provides the exceptionally rich fuel/air ratio that is necessary to enable easy starting when the engine is cold. When starting the engine, the choke valves close down the carburetor bores by pulling up the choke lever. Since the choke valves close down the carburetor bores, a high intake vacuum (suction or low pressure) is developed at the engine side of the carburetor bores. The choke valves are opened by a high intake vacuum, and air is drawn into the carburetor bores. As the engine is cranked over, fuel is drawn in from the float chamber through the main jets and pilot jet. This fuel is then drawn into the carburetor, mixed with the air drawn in through the choke valve, and drain into the engine.

152 MAINTENANCE—ENGINE

The engine must be run at a faster than normal idle speed to prevent the engine from stalling until it reaches operating temperature. To accomplish this, the fast idle cam pushes the idling link when the choke lever is pulled up, and the butterfly valve is held open an amount sufficient to prevent stalling.

Starter System

H6

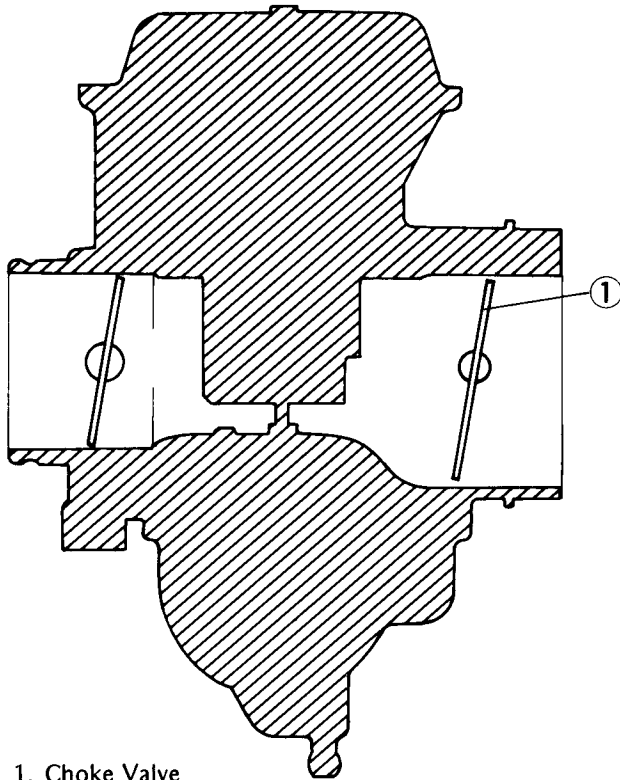

1. Choke Valve

In order for the starter system to work properly, the choke lever must be pushed up fully so that the choke valve will be kept closed and sufficient vacuum can be built up at the engine of the carburetor bore. Clogged pilot jet, main jets, pilot air jet, needle jet holder, and main jet bleed pipe will cause insufficient atomization, thus impairing starter efficiency. Fuel mixture trouble results if choke lever link mechanism, pilot and main system is defective. A damaged choke valve will cause insufficient vacuum, this impairing starter system efficiency. Fuel mixture trouble results if the choke valve does not open fully after the choke lever is returned.

Cleaning and inspection

(See cautions on Pg. 151)

Disassemble the carburetor, and wash the main jets, pilot jet, needle jet holder, main jet bleed pipe, air jets, and air passage with a high flash-point solvent, blowing them clean with compressed air. If necessary.

Fast Idle Mechanism

H7

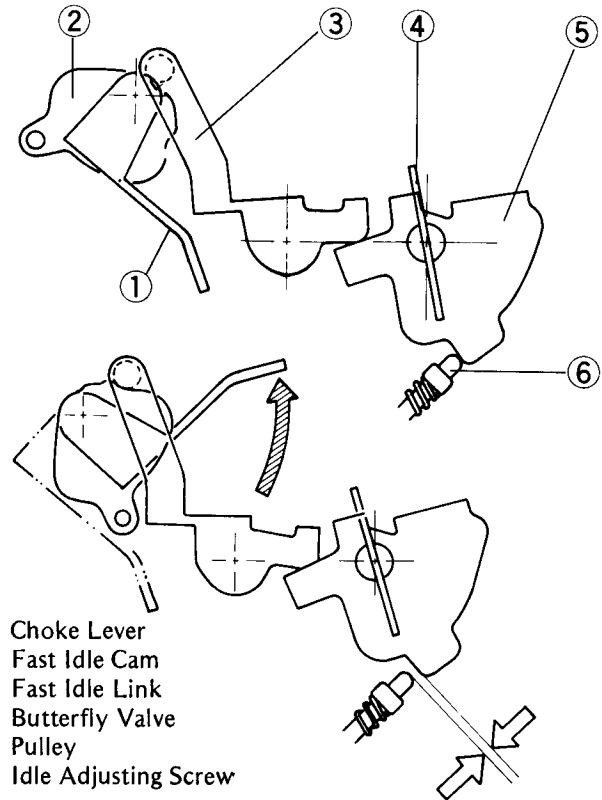

1. Choke Lever
2. Fast Idle Cam
3. Fast Idle Link
4. Butterfly Valve
5. Pulley
6. Idle Adjusting Screw

Pull up and push down the choke lever to check that the choke valves move smoothly. The choke valves must close the carburetor bores completely when the lever is pulled up, and must open fully when the lever is pushed down. To check that the choke link spring is working properly, push on the choke valve itself. The choke valve must move smoothly, and must close by spring tension.

If the choke valve or the choke link spring does not work properly, replace the carburetor body.

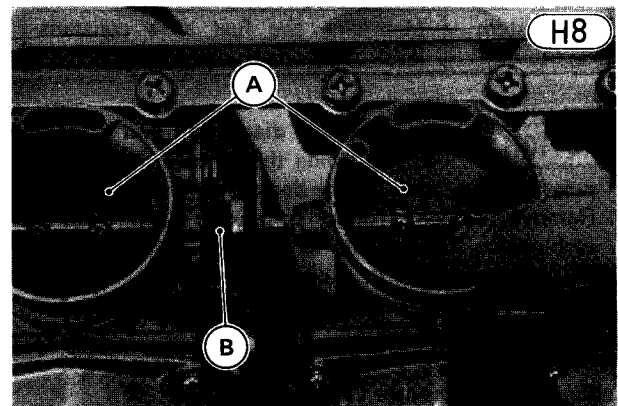

A. Choke Valves

B. Choke Link Spring

Pilot System

Fig. H9 shows the pilot system, which includes the pilot air jet (10), pilot jet (8), primary main jet (6), bypass

Pilot System

(H9)

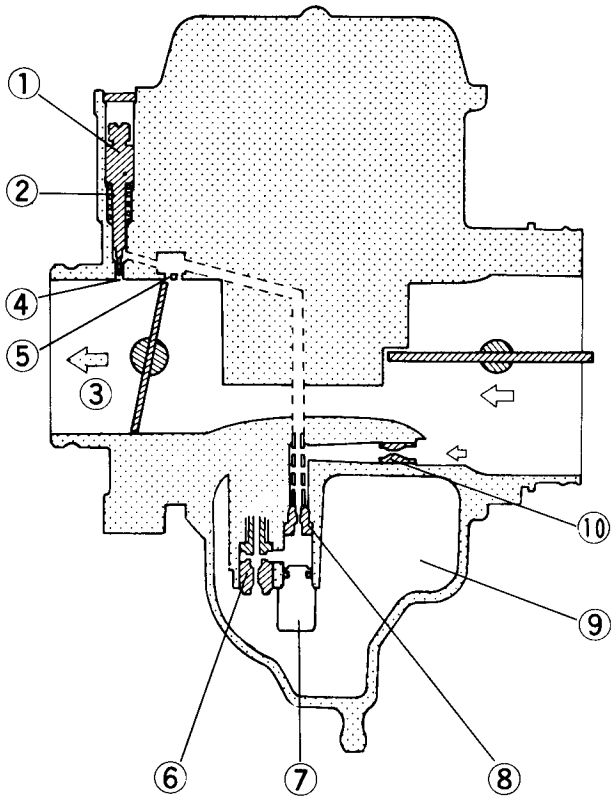

- | | |
|--------------------|---------------------|
| 1. Pilot Screw | 6. Primary Main Jet |
| 2. Spring | 7. Plastic Plug |
| 3. Carburetor Bore | 8. Pilot Jet |
| 4. Pilot Outlet | 9. Float Chamber |
| 5. Bypass Outlet | 10. Pilot Air Jet |

Pilot System Fuel and Air Supply

(H10)

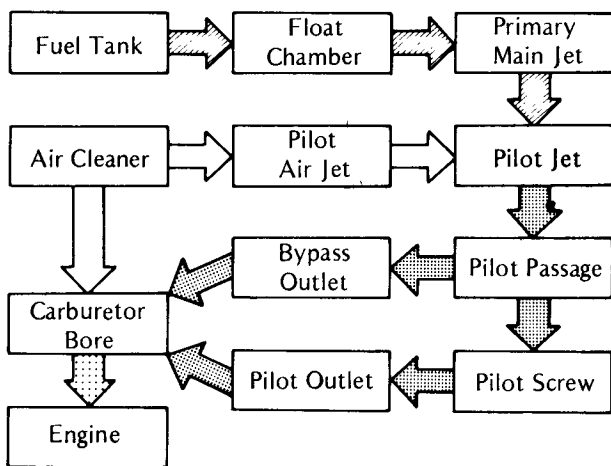

The pilot system determines the operation of the carburetor from 0 to ¼ throttle opening. At small throttle openings, almost no fuel is drawn through the main system due to insufficient air flow. Instead, the

of the low pressure (suction) brought about by the demand for air by the engine and the limited but relatively fast flow of air past the pilot outlet. The almost closed position of the butterfly valve restricts the carburetor bore air flow, preventing it from relieving the low pressure created by the engine around the pilot outlet while the Venturi effect (the narrower the air passage, the faster the flow of air) at the engine side of the butterfly valve further reduces the low pressure.

The supply of the fuel and air in the pilot system is shown in Fig. H10. At idling and slightly about, the fuel passes through the main jet, and is then metered at the pilot jet, where the fuel mixes with air metered by the pilot air jet. Then, the fuel passes through the pilot passage, where the pilot screw affects the flow, through the pilot outlet into the carburetor bore, and to the engine. As the butterfly valve turns a little more, the butterfly valve position extends the low pressure area to the pilot bypass, allowing fuel to bypass part of the pilot passage to go directly to the carburetor bore such that the supply of fuel increases sufficiently with engine need.

Fig. H11 shows through opening versus fuel flow for the main and pilot systems. If trouble occurs in the pilot system, not only are starting and low speed running affected, but the transition from pilot to main system is not smooth as the throttle is opened, causing a drop in engine efficiency. Pilot system trouble might be to maladjustment; a dirty or loose, pilot jet, or pilot air jet; or clogging of the main jet, pilot passage, pilot outlet, or pilot bypass.

Fuel Flow Characteristics

(H11)

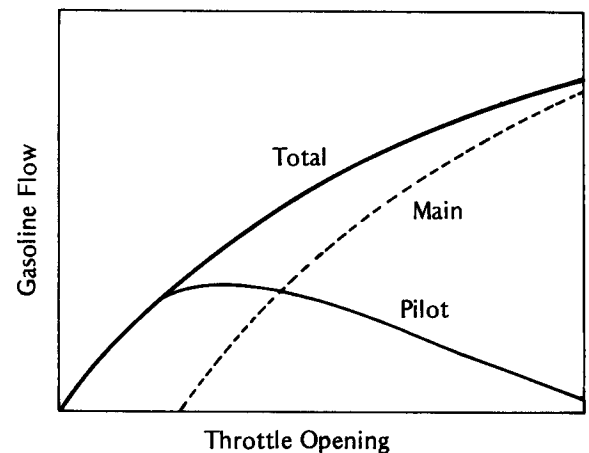

Cleaning and replacement

(See cautions on Pg. 151)

Disassemble the carburetor, and wash the primary main jet, pilot jet, pilot air jet, and air passage with a high flash-point solvent, blowing them clean with compressed air. If necessary, use a bath of automotive type carburetor cleaning.

Remove the pilot screw, and check that the tapered portion is not worn or otherwise deformed. If it is, replace the screw. If the screw O ring is damaged, replace

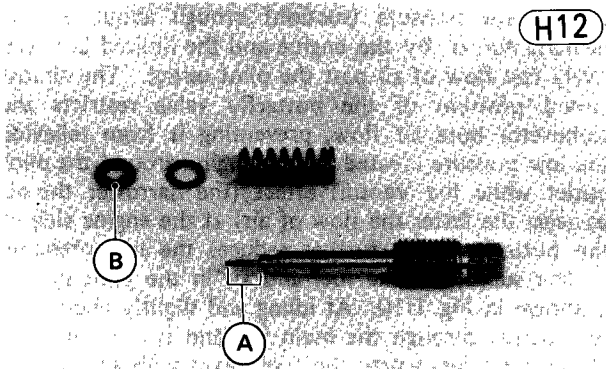

H12

A. Tapered Portion B. "O" Ring

Main System

Fig. H13 shows the main system, which consists of the main jets ①, ⑮, main jet bleed pipe ⑩, needle jet holder ⑭, jet needle ④, needle jet ⑬, vacuum piston ②, spring ③, and main air jets ⑦, ⑧.

Main System

H13

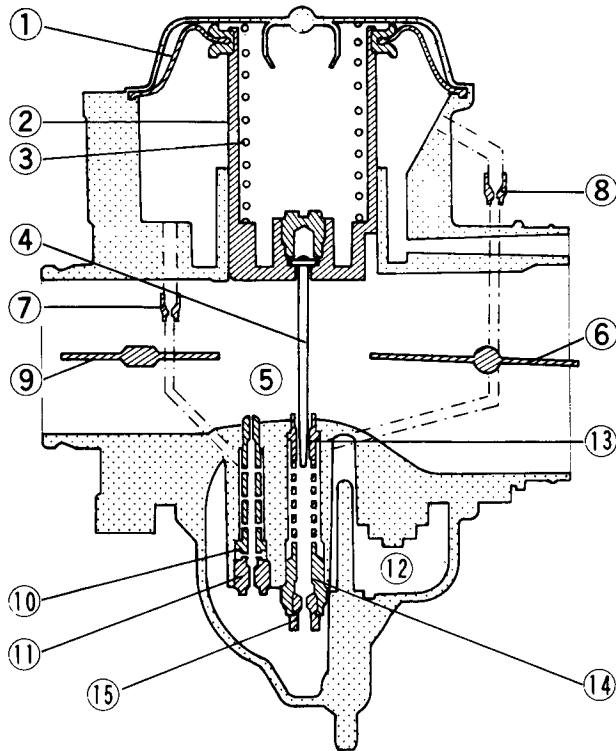

- | | |
|-------------------------|------------------------|
| 1. Diaphragm | 9. Butterfly Valve |
| 2. Vacuum Piston | 10. Bleed Pipe |
| 3. Spring | 11. Primary Main Jet |
| 4. Jet Needle | 12. Float Chamber |
| 5. Carburetor Bore | 13. Needle Jet |
| 6. Choke Valve | 14. Needle Jet Holder |
| 7. Primary Main Air Jet | 15. Secondary Main Jet |
| 8. Secondary Main Air | |

Main System Fuel and Air Supply

H14

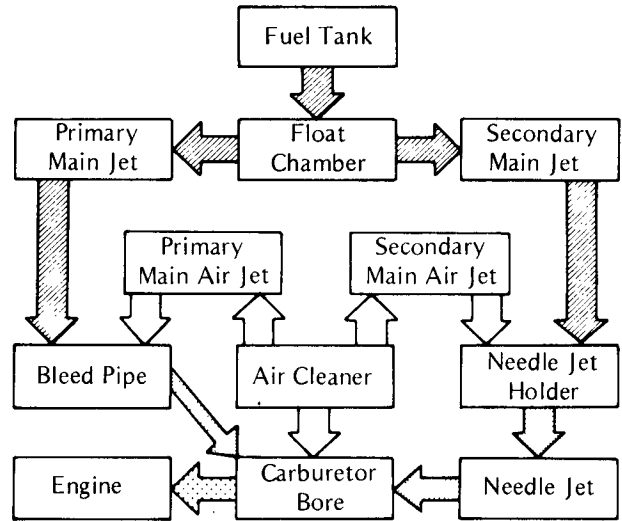

Fig. H14 shows the supply of fuel and air in the main system. From about ¼~½ throttle opening, the air flow past the main jet bleed pipe is sufficient to cause fuel to be drawn through the main system, and from about ½ throttle opening, the air flow past the needle jet outlet is sufficient too. The fuel passes through the primary main jet and then part of it goes through the slow jet as in the pilot system while the rest of it passes straight up through the main jet bleed pipe at about ¼ ~ ½ throttle opening, and from about ½ throttle opening, the fuel passes through the secondary main jet and then it goes straight up through the space in the needle jet not blocked by the jet needle and into the carburetor bore, where it is atomized by the air flow to the engine.

The needle jet holder and main jet bleed pipe have holes to admit the air metered by the main air jets. This air mixes with the fuel in the needle jet holder and main jet bleed pipe to prepare the fuel for better atomization in the carburetor bore.

The lower part of the jet needle is tapered and extends down into the needle jet and needle jet holder. It is fixed to the vacuum piston, and thus rises up in the needle jet and needle jet holder as the vacuum piston rises. From the time the vacuum piston starts rising, from about ¼ throttle, until it reaches most of the way up in the carburetor bore, the fuel is metered primarily by the primary main jet and secondarily by the jet needle taper. As the jet needle rises, the needle to jet clearance increases, thereby increasing the amount of fuel that can pass up through the jet.

The vacuum piston is attached to the diaphragm and rises only between ¼ and ¾ throttle. Through the holes in the bottom of the piston, the air pressure in the chamber above the diaphragm is reduced by engine intake vacuum. The air vent maintains atmospheric pressure in the chamber under the diaphragm. As engine speed increases, air pressure in the upper chamber decreases. The difference between this pressure and at-

greater. The force of the spring and the weight of the piston are overcome, and the piston rises to an extent corresponding to this pressure difference. The diaphragm is made of rubber and absorbs the vibration caused by engine intake pulsing to prevent the vacuum piston from wearing.

Venturi Principle

H15

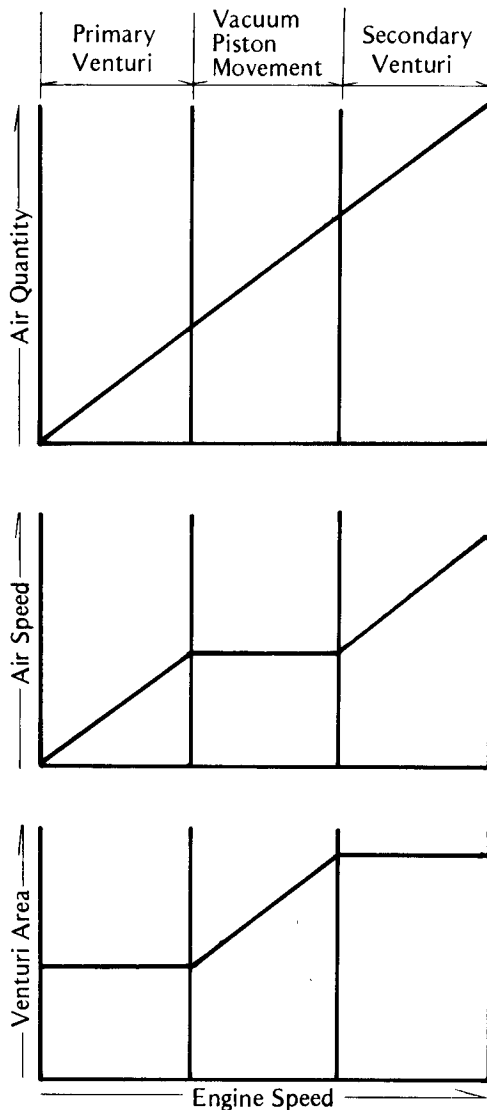

As shown in Fig. H15 the quantity of air drawn in by the engine intake is in direct proportion to engine rpm, and the speed of the air flow is constant while the vacuum piston rises from 1/4 to 3/4 throttle. Were the size of the air passage above the needle jet to change simultaneously with throttle movement rather than with engine intake (demand), the speed of the air flow in the air passage might even drop during a rapid increase

stall in acceleration. However, the vacuum piston-butterfly valve arrangement controls both the air and fuel supply at sudden throttle for smooth and immediate engine response.

At 3/4 throttle the vacuum piston reaches its highest position, forming the "secondary venturi" to permit maximum engine output. At near full throttle openings, the cross-sectional area of the needle to jet clearance becomes greater than the cross-sectional area of the main jet. At these openings, the fuel drawn up into the carburetor bore is limited by the size of the main jet rather than the needle to jet clearance.

Trouble in the main system is usually indicated by poor running or lack of power at high speeds. Dirty or clogged main jets will cause the mixture to become too lean. An overly rich mixture could be caused by clogging of the main air jets, its air passage, or the air holes in the main jet bleed pipe and needle jet holder; by needle jet or needle wear (increasing clearance); by loose main air jets; or by a loose needle jet.

Cleaning and adjustment (See cautions Pg. 151)

Disassemble the carburetor, and wash the vacuum piston, main jets, main jet bleed pipe, main jet holder, needle jet, jet needle, main air jets, and air passage with a high flash-point solvent, blowing them clean with compressed air. If necessary, use a bath of automotive type carburetor cleaner.

Visually inspect the diaphragm. If there is any tear or other damage, the piston and diaphragm should be replaced.

Float System

Fig. H16 shows the float system which consists of the float ⑤, float valve needle ②, float valve seat ①, and overflow pipe ④.

The float system serves to keep a relatively constant level of fuel in the carburetor float chamber at all times so that the fuel supply to the engine will be stable. If the fuel level in the float chamber is set too low, it will be more difficult for fuel to be drawn up into the carburetor bore, resulting in too lean a mixture. If the level is set too high, the fuel can be drawn up too easily, resulting in too rich a mixture.

The design fuel level is defined as the vertical distance from the center of the carburetor bore to the surface of the fuel in the float chamber. The fuel level is maintained at a constant value by the action of the float valve, which opens and closes according to the fuel level. As fuel flows through the float valve into the chamber, the fuel level rises. The float, rising with the fuel level, pushes up on the needle. When the fuel reaches a certain level, the needle is pushed completely into the valve seat, which closes the valve so that no more fuel may enter the chamber. As the fuel is drawn up out of the float chamber, the fuel level drops, lowering the float. The needle no longer blocks the float valve, and fuel once

156 MAINTENANCE—ENGINE

NOTE: It is impractical to measure the actual design fuel level. Service fuel level is defined as the vertical distance from the bottom edge of the carburetor body to the surface of the fuel in the float chamber. Measuring the service fuel level is an indirect method of inspecting for correct design fuel level.

Float System

H16

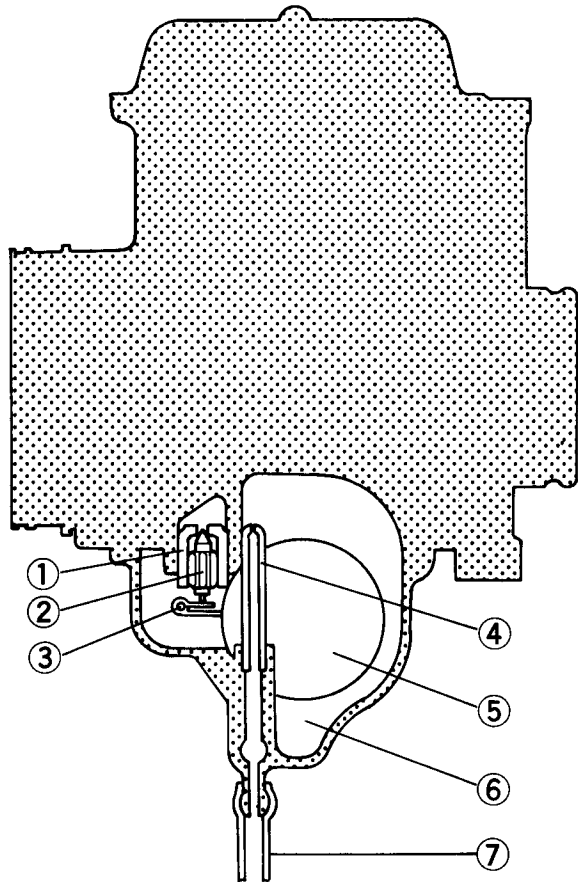

1. Valve Seat
2. Valve Needle
3. Float Pin

4. Overflow Pipe
5. Float
6. Float Chamber
7. Overflow Tube

Service fuel level measurement and adjustment

If the motorcycle exhibits symptoms of improper fuel mixture, measure the service fuel level.

Secure the motorcycle in a true vertical position. Turn the fuel tap to the "ON" or "RES" position, and attach the fuel level gauge (special tool) to the open end of the overflow tube. Hold the gauge against the side of the carburetor so that the "0" line is even with the bottom edge of the carburetor body. Turn the fuel tap to the "PRI" position, and turn out the drain plug 1~2 turns. Wait until no air bubbles can be seen rising up through the fuel from the overflow tube, and read the service fuel level in the gauge.

NOTE: Measure the fuel level keeping the carburetor

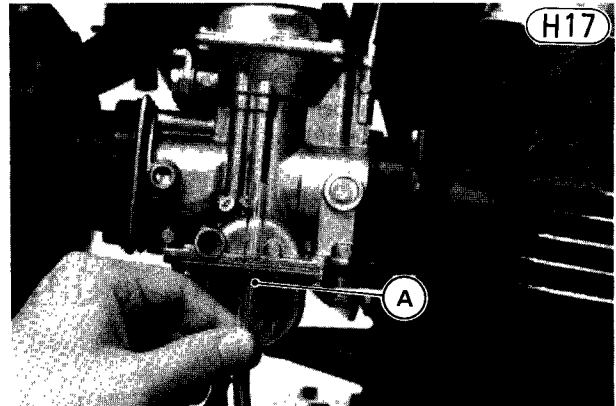

A. Fuel Level Gauge (57001-1017)

Service Fuel Level Measurement

H18

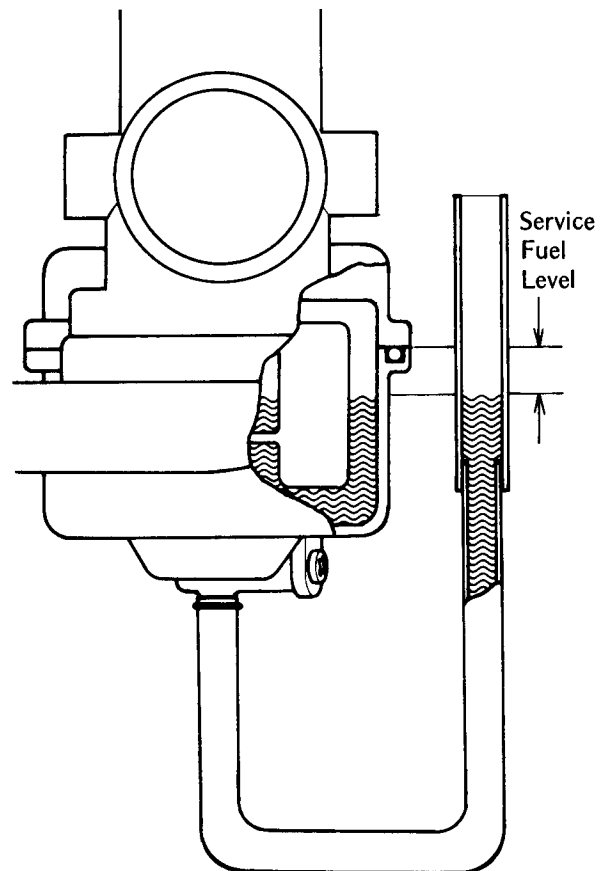
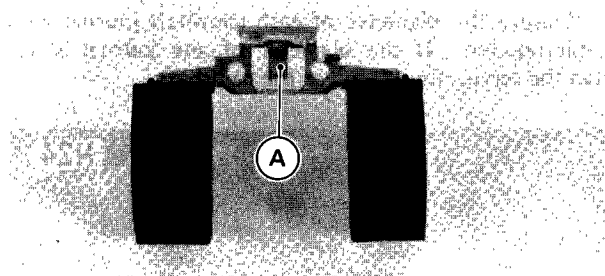

Table H5 Service Fuel Level

Standard
4.0 ± 1 mm below from the bottom edge of the carburetor body to the fuel level

If the fuel level is incorrect, remove the carburetor, and then remove the float bowl and float. Bend the tang on the float a very slight amount to change the fuel level. Bending it up closes the valve sooner and lowers

H19



A. Tang

After adjustment, measure the service fuel level again, and readjust if necessary.

Cleaning and replacement
(See caution on Pg. 151)

If dirt gets between the needle and seat, the float valve will not close and fuel will overflow. Overflow can also result if the needle and seat become worn. If the needle sticks closed, no fuel will flow into the carburetor.

Remove the carburetor, and take off the float bowl and float. Wash the bowl and float parts in a high flash-point solvent. Use carburetor cleaner if necessary on the float bowl and metal parts only. Blow out the fuel overflow pipe with compressed air.

Examine the float, and replace if damaged. If the needle is worn as shown in the diagram, replace the carburetor body.

Valve Needle

H20

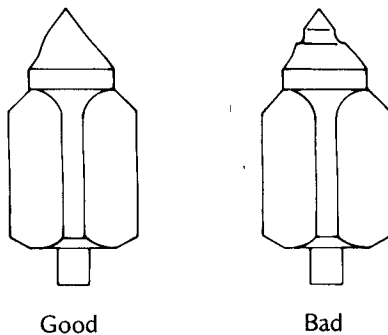

top of the cylinder head. One is the inlet camshaft, and is manufactured with four cam lobes, one to open the inlet valve for each cylinder. The other is the exhaust camshaft, and has four cam lobes to open the exhaust valves. There is a sprocket at the center of the crankshaft and at the center of each camshaft. A chain placed over these sprockets enables the crankshaft to turn both camshafts so that the valves will be opened and closed at the proper times during each rotation of the engine.

Each sprocket has marks so that valve timing (the time that each valve is opened) can be reset correctly any time the camshafts are removed for inspection or repairs.

However, since the time, amount, and duration that each valve is opened (valve timing) changes with cam wear, journal wear, and camshaft runout (bend), the camshafts should be inspected periodically and whenever timing trouble is suspected. If the valves do not open at the right times or if they do not open the correct amount or for the proper duration, there will be a decrease in combustion efficiency, causing a loss of engine power and leading to serious engine trouble.

Valve Timing

H21

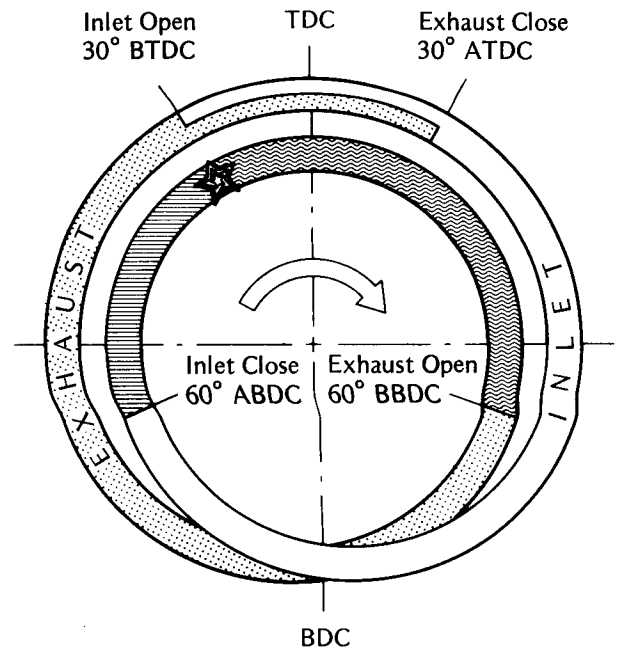

Cam wear

Remove the camshafts, and measure the height of each cam with a micrometer. If the cams are worn down past the service limit, replace the camshafts.

CAMSHAFT

Since this engine is a DOHC (Double Over Head

Table H6 Cam Height

Service Limit	35.65 mm
---------------	----------

Cam Height Measurement

H22

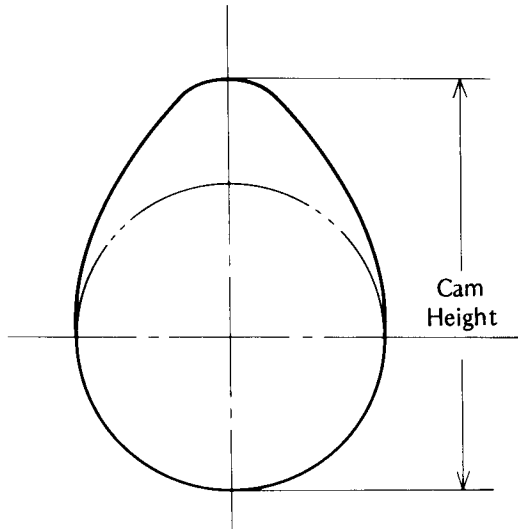

Journal, bearing wear

The journal wear is measured using plastigauge (press gauge), which is inserted into the clearance to be measured. The plastigauge indicates the clearance by the amount it is compressed and widened when the parts are assembled.

Remove the camshaft, and wipe each journal and camshaft cap surface clean of oil. Cut strips of plastigauge to journal width. Place a strip on each journal parallel to the camshaft and so that the plastigauge will be compressed between the journal and camshaft cap.

Now, fit the chain over the camshaft sprocket so the shaft won't turn, and install the camshaft, tightening the bolts in the correct sequence with the specified torque (Pg. 35).

CAUTION While installing the camshaft, be sure to reset it correctly (Pg. 54). If it is installed incorrectly, valves may be bent.

Next, remove the camshaft cap again, and measure the plastigauge width to determine the clearance between each journal and the camshaft cap.

If any clearance exceeds the limit, measure the diameter of the camshaft journal and the bearing inside diameter.

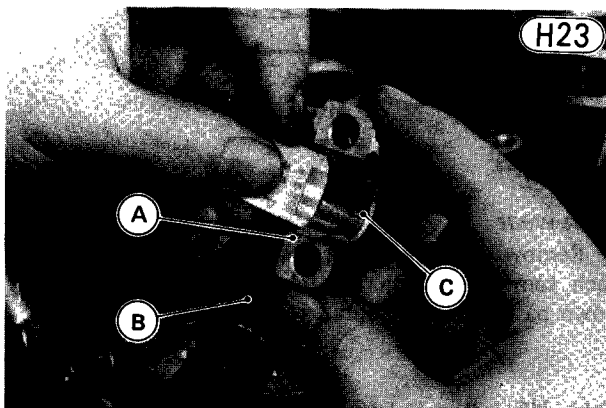

A. Camshaft Cap

C. Plastigauge

Table H7 Camshaft Journal/Camshaft Cap Clearance

Service Limit	0.19 mm
---------------	---------

Measure the diameter of each camshaft journal with a micrometer. If the diameter of any journal is less than the service limit, replace the camshaft.

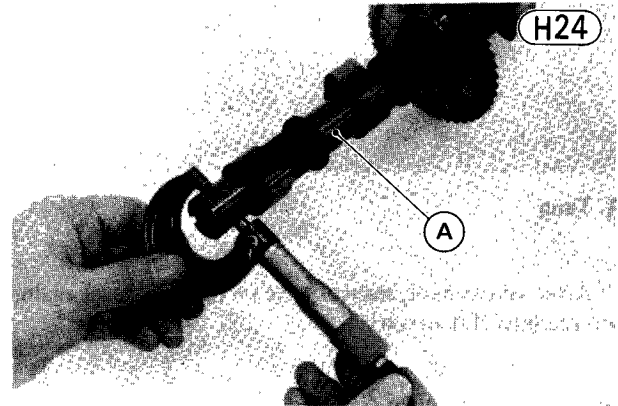

A. Camshaft

Table H8 Camshaft Journal Diameter

Service Limit	21.93 mm
---------------	----------

Remove the camshafts, and tighten the camshaft caps with the specified torque (Pg. 35). Measure the vertical inside diameter of each bearing with a cylinder gauge. If it exceeds the service limit, replace the cylinder head and camshaft caps as a set since the camshaft caps are machined together with the cylinder head.

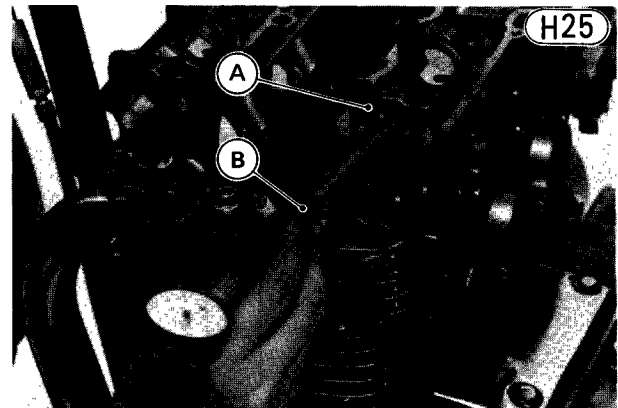

A. Camshaft Cap

B. Cylinder Gauge

Table H9 Camshaft Bearing Inside Diameter

Service Limit	22.12 mm
---------------	----------

Camshaft runout

Remove the camshaft and take the sprocket off the shaft.

Set the shaft on V blocks at the outside journals as shown in the figure. Measure runout with a dial gauge at the sprocket mounting location, and replace

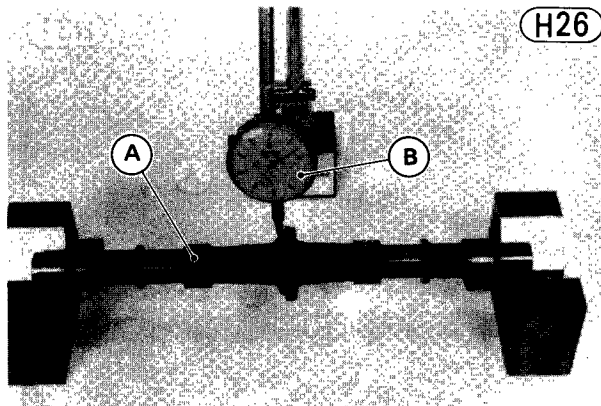

A. Camshaft B. Dial Gauge

Table H10 Camshaft Runout

Service Limit	0.1 mm
---------------	--------

CAMSHAFT CHAIN, GUIDE, TENSIONER

The camshaft chain, which is driven by the crankshaft sprocket, drives the two camshafts at one-half crankshaft speed. For maximum durability and minimum noise, an endless-type silent chain with no master link is used.

The automatic camshaft chain tensioner of ball-lock type is utilized for this machine. Periodic adjustment of the tensioner is not needed since chain slack is removed automatically.

The tensioner consists of push rod ①, lock balls ⑤, springs ③, ④, lock ball stop ② (press-fitted onto the tensioner body), tensioner body ⑧, and bolt. When the slack appears on the chain, the push rod is pushed out to the chain by the spring ③, and it cannot be pushed back in because of the lock balls locking on the ramp of the stop. The bolt is used to keep the push rod from flying out during installation, and it is also used to keep the push rod from falling down into the crankcase after installation.

Camshaft Chain Tensioner

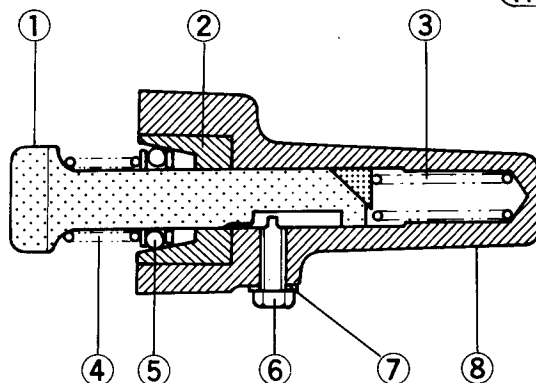

- 1. Push Rod
- 2. Lock Ball Stop
- 3. Spring
- 4. Lock Bolt
- 5. Ball and Retainer
- 6. Lock Bolt
- 7. Flat Washer
- 8. Tensioner Body

When the chain can no longer be adjusted enough to stop it from making noise, remove the chain, guides, and tensioner for inspections.

Camshaft chain wear

Hold the chain taut with a force of about 5 kg in some manner, and measure a 20-link length. Since the camshaft chain may wear unevenly, take measurements at several places. If any measurement exceeds the service limit, replace the chain.

Chain Length Measurement

H28

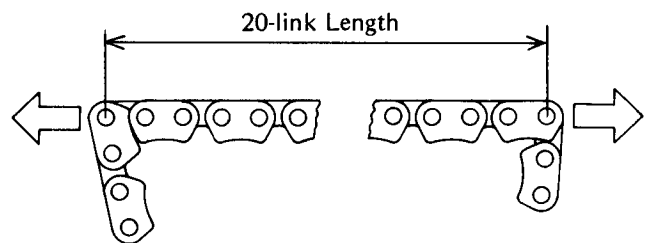

Table H11 Camshaft Chain Length

Service Limit	128.9 mm
---------------	----------

Chain guide wear

Remove all the chain guides, and inspect them visually. Replace them if the rubber or any other portion shows damage.

Measure the depth of the grooves where the chain links run. Replace the guide if the wear exceeds the service limit.

Chain Guide Rubber Wear

H29

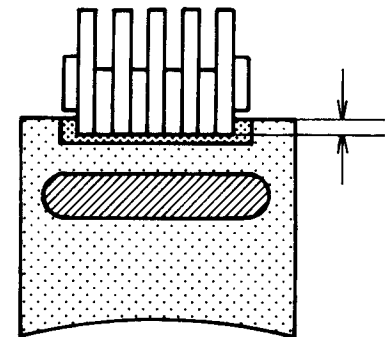

Table H12 Chain Guide Wear

Guide	Upper	Front	Rear
Service Limit	2.5 mm	2.2 mm	2.5 mm

160 MAINTENANCE—ENGINE

Chain tensioner inspection

Remove the chain tensioner. Visually inspect the push rod, lock balls, ball stop, and springs. If there is any damage or dent, replace the part with a new one.

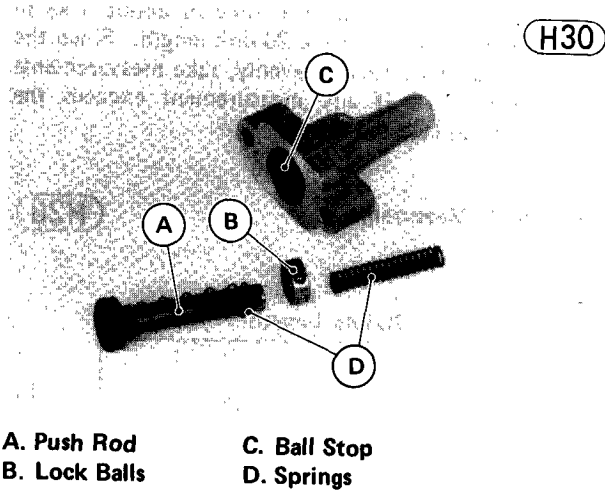

H30

A. Push Rod
B. Lock Balls

C. Ball Stop
D. Springs

CYLINDER HEAD, VALVE

The valves are mounted in the head, they are pushed open by the cams, and closed by the valve springs.

The valve guides and valve seats are pressed into the cylinder head. The valve seat prevents compression leakage by fitting snugly against the valve. It also prevents the valve from overheating by allowing efficient head transfer.

Cylinder Head

The cylinder head is made of aluminum alloy, used for its high heat conductivity, and is finned on the outside to aid dissipation of the heat generated in the combustion chambers. Carbon built up inside the combustion chambers interferes with heat dissipation and increases the compression ratio; which may result in preignition, detonation, and overheating. Trouble can also arise from improper head mounting or mounting torque, which may cause compression leakage.

Cleaning and inspection

Remove the cylinder head (Pg. 57) and valves (Pg. 58). Scrape out any carbon, and wash the head with a

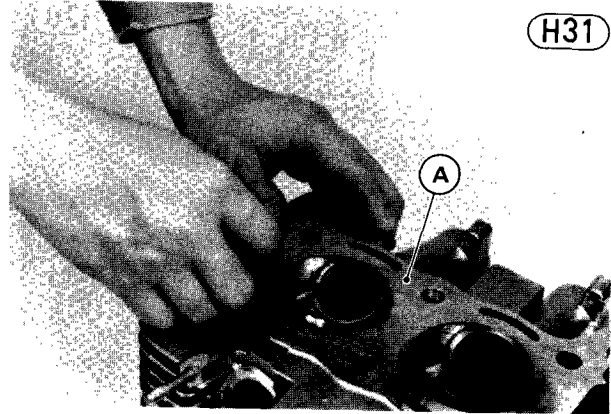

H31

A. Cylinder Head

Cylinder head warp

Lay a straightedge across the lower surface of the head at several different points, and measure warp by inserting a thickness gauge between the straightedge and the head. If warp exceeds the service limit, replace the cylinder head.

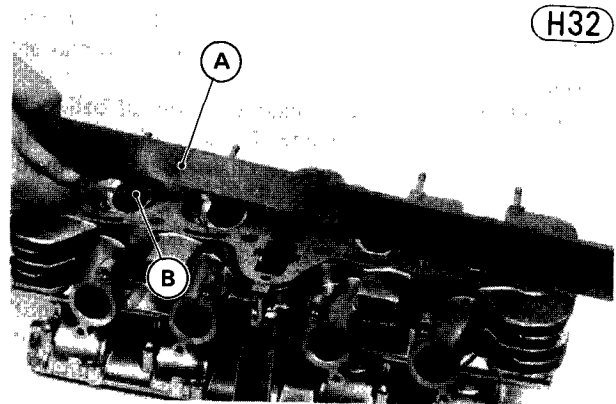

H32

A. Straightedge

B. Thickness Gauge

Table H13 Cylinder Head Warp

Service Limit	0.05 mm
---------------	---------

Combustion chamber volume measurement

The combustion chamber volume should be measured any time that compression measurement results in compression pressures well below or above the standard.

NOTES:

1. Another person will be needed to help expel air bubbles out of the combustion chamber.
2. Prepare a piece of transparent plastic plate which has a flat surface and two holes about 35 mm apart in its center portion. One hole should be about 6 mm in diameter, the other about 3 mm in diameter. The plate must be oil resistant about 120 mm

Measuring Plastic Plate

H33

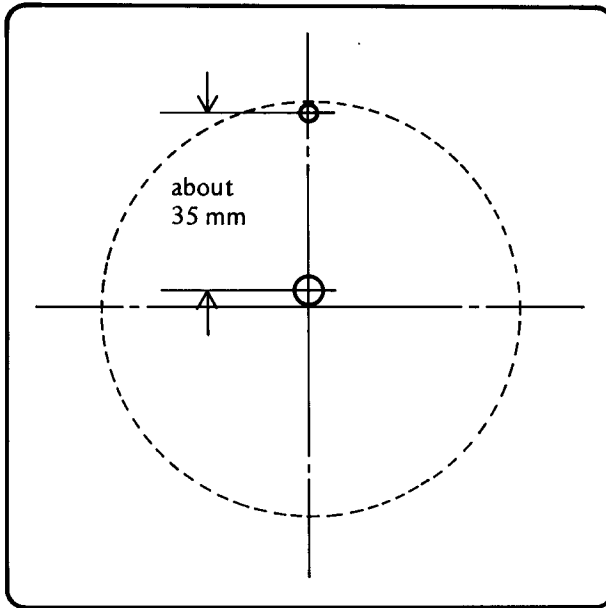

3. Obtain a burette or syringe which is calibrated at one-cc or smaller graduations. Fill it with thin oil.

Prior to the combustion chamber volume measurement, clean off any carbon on the combustion chamber, and remove any gasket flakes on the cylinder head mating surface. The standard spark plug should be installed in the chamber to be measured.

NOTE: The valves must seat well to prevent the oil from leaking out.

Apply a thin coat of grease to the cylinder head mating surface and place the plastic plate over the cylinder head combustion chamber, fitting its small hole near the edge of the combustion chamber.

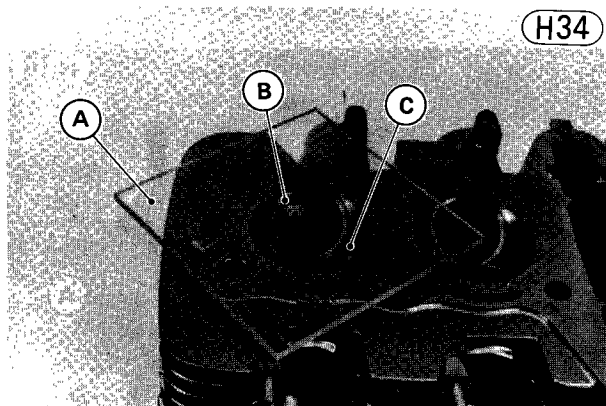

H34

A. Plastic Plate
B. Large Hole

C. Small Hole

Place the cylinder head on a level surface. Through the large hole, fill the combustion chamber with light oil such as 2-stroke oil or mission oil until the chamber

head slightly so that air bubbles come out through the small hole. The oil should just rise to the bottom edge of the holes in the plate.

The amount of oil used to fill the chamber is the combustion chamber volume.

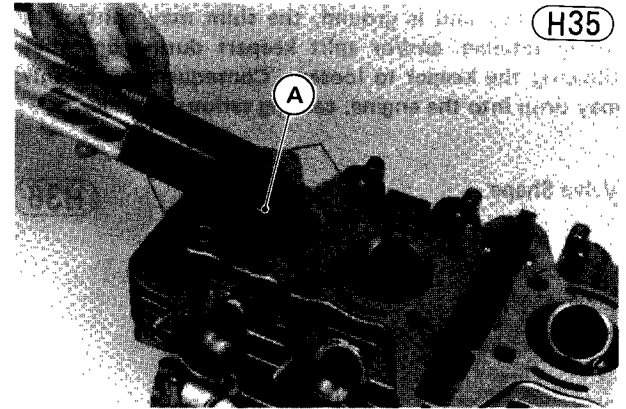

H35

A. Oil

Table H14 Combustion Chamber Volume

Standard	24.8 cc
----------	---------

If the combustion chamber volume is too small, it is possible that the cylinder head was modified for higher compression. Make sure that all carbon deposits have been cleaned out of the chamber.

If the combustion chamber volume is too large, it is possible that the valves and valve seats have been resurfaced so much that the volume is increased. Make sure that the spark plug is the standard type and that it is fully tightened.

Valve, Valve Guide, Valve Seat

Valve face deformation or wear, stem bending or wear, and valve guide wear can cause poor valve seating. Poor seating can also be caused by the valve seat itself, if there is heat damage or carbon build-up. The result of poor valve seating is compression leakage and a loss of engine power.

In addition, valve and valve seat wear causes deeper valve seating and a decrease in valve clearance. Insufficient clearance upsets valve timing and may eventually prevent the valve from seating fully. So that wear never progresses this far, adjust the valve clearance in accordance with the Periodic Maintenance Chart (Pg. 10).

Valve inspection

Visually inspect the valve face, and replace the valve if it shows deformation or uneven wear.

Measure the thickness of the valve head using vernier calipers, and replace the valve if the thickness is under

162 MAINTENANCE—ENGINE

If the seating surface of the valve is damaged or badly worn, repair the valve with a valve refacer. The angle of the seating surface is 45° .

If the end of the valve stem is damaged or badly worn, replace the valve with a new one.

CAUTION Do not grind the valve stem end to repair it or to permit additional valve clearance. If the valve end is ground, the shim may contact the spring retainer and/or split keepers during operation, allowing the keeper to loosen. Consequently, the valve may drop into the engine, causing serious damage.

Valve Shape

(H36)

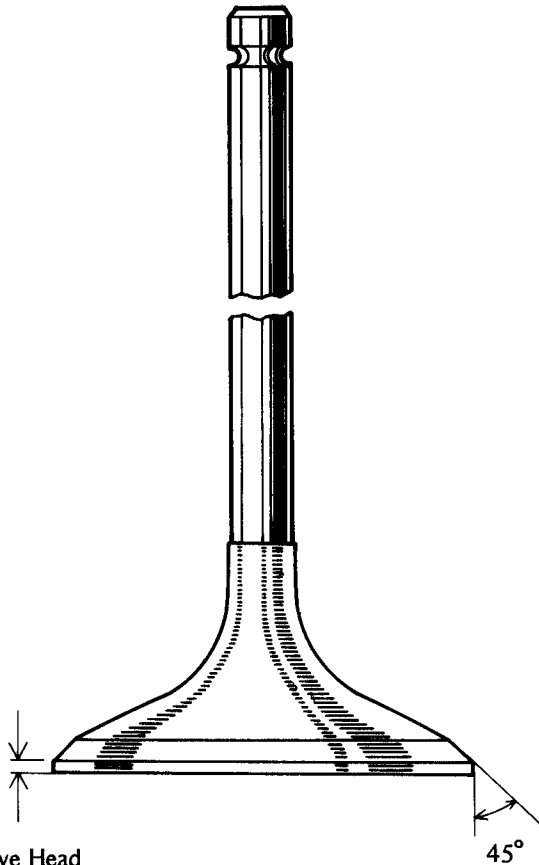

Valve Head
Thickness

Table H15 Valve Head Thickness

	Inlet	Exhaust
Service Limit	0.5 mm	0.7 mm

Position the valve in V blocks at each end of the straight portion of the stem, and set a dial gauge against the center of the stem. See the example shown in Fig. H37.

Turning the valve, read the variation in the dial gauge. Replace the valve if it is bent more than the service limit.

Table H16 Valve Stem Bend

Service Limit	0.05 mm
---------------	---------

Valve Stem Bend

(H37)

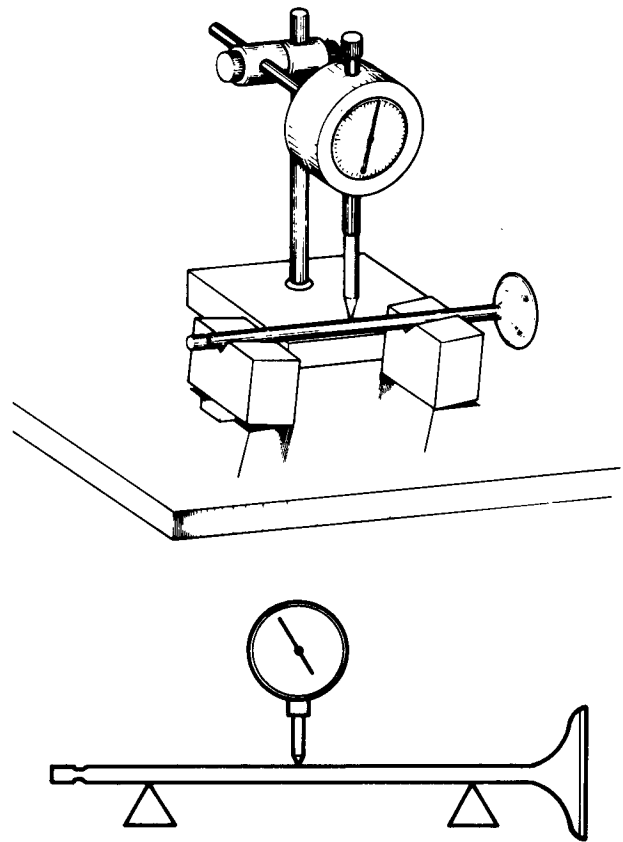

Measure the diameter of the valve stem with a micrometer. Since the stem wears unevenly, take measurements at four places up and down the stem, keeping the micrometer at right angles to the stem.

Replace the valve if the stem is worn to less than the service limit.

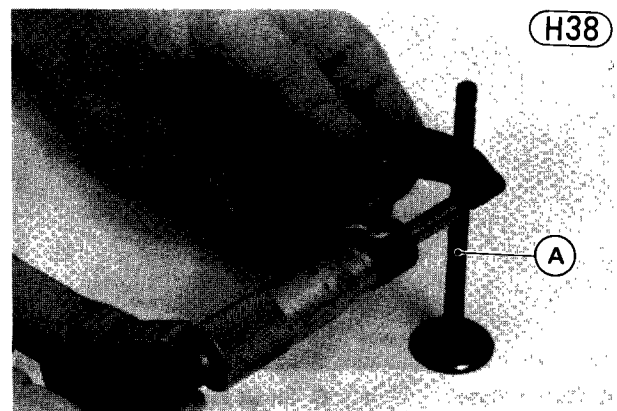

A. Valve Stem

Table H17 Valve Stem Diameter

Service Limit	6.89 mm
---------------	---------

Valve guide inspection

Remove the valve, and measure the inside diameter of the valve guide using a small bore gauge and micrometer. Since the guide wears unevenly, measure the diameter at four places up and down the guide. If any measurement exceeds the service limit, replace the guide.

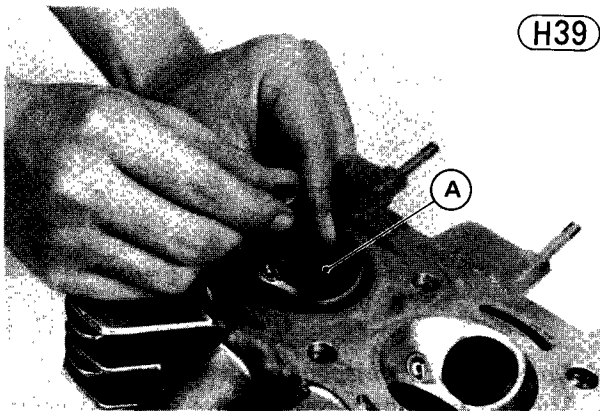

A. Small Bore Gauge

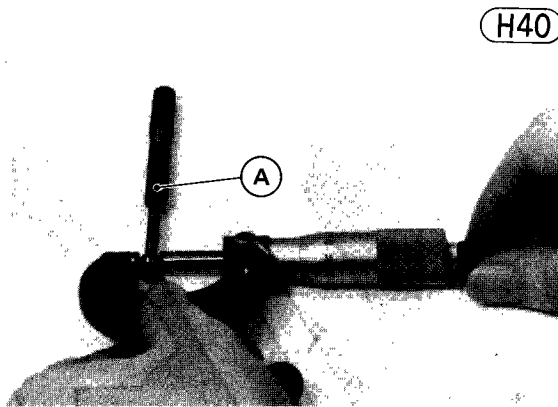

A. Small Bore Gauge

Table H18 Valve Guide Inside Diameter

Service Limit	7.08 mm
---------------	---------

If a small bore gauge is not available, inspect the valve guide wear by measuring the valve to valve guide clearance with the wobble method, as indicated below.

Insert a new valve into the guide and set a dial gauge against the stem perpendicular to it as close as possible to the cylinder head mating surface. Move the stem back and force to measure valve/valve guide clearance. Repeat the measurement in a direction at a right angle to the first.

If the reading exceeds the service limit, replace the guide.

NOTE: The reading is not actual valve/valve guide clear-

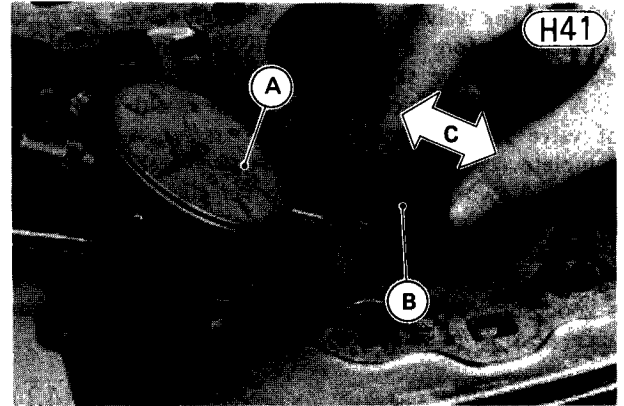

A. Dial Gauge

B. New Valve

C. Move.

Table H19 Valve/Valve Guide Clearance (Wobble Method)

	Inlet	Exhaust
Service Limit	0.24 mm	0.19 mm

Valve seat repair

The valve must seat in the valve seat evenly around the circumference over the specified area. If the seat is too wide, the seating pressure per unit of area is reduced, which may result in compression leakage and carbon accumulation on the seating surface. If the seating area is too narrow, heat transfer from the valve is reduced and the valve will overheat and warp. Uneven seating or seat damage will cause compression leakage.

Valve Seating Width

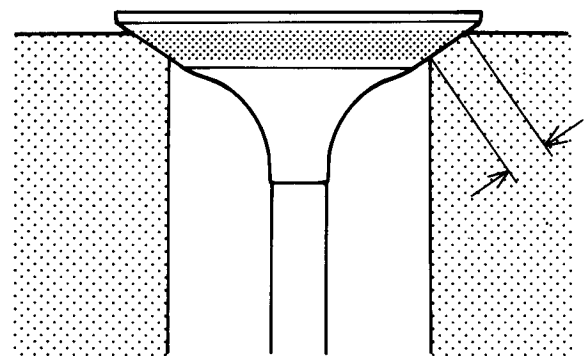

Table H20 Valve Seating Width

Standard	0.5 ~ 1.0 mm
----------	--------------

To determine whether or not the valve seat requires repair, first remove the valve, apply machinist's dye to the valve seat, and then use a lapper to tap the valve lightly into place. Remove the valve, and note where the dye adheres to the valve seating surface. The valve seating surface should be in the middle of the valve face (Fig. H42). The distribution of the dye on the seating

164 MAINTENANCE—ENGINE

NOTE: The valve and valve guide must be in good condition before this check will give an accurate indication of valve seat condition.

A valve seat which requires repair is cut with a set of valve seat cutters. Four cutters are required for complete repair; one 30° (inlet valve seat only); one 45°; and two 60° cutters, one for the inlet and the other for the exhaust.

First, cut the seating surface of the valve seat with the 45° cutter. Cut only the amount necessary to make a good surface; overcutting will reduce the valve clearance, possibly making it no longer adjustable.

Valve Seat Cutter

(H43)

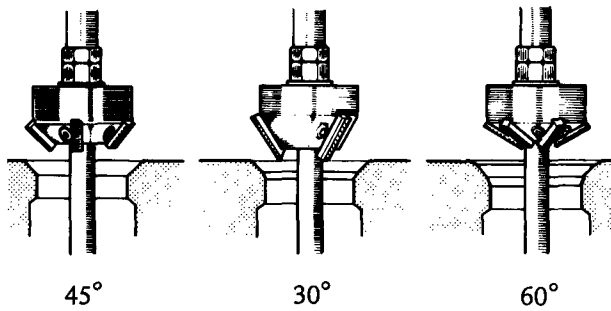

Cutting Angle of Valve Seat

(H44)

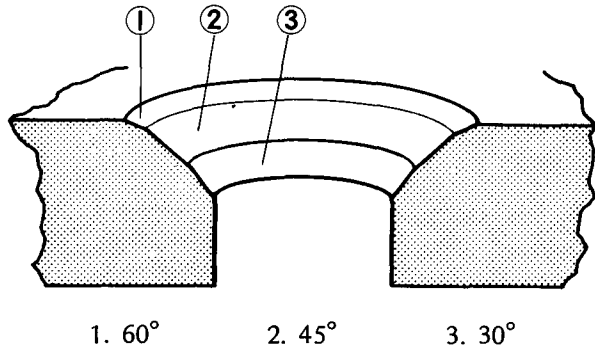

Next, use the 30° cutter (inlet valve seat only) to cut the surface inside the seating surface, and then use the 60° cutter to cut the outermost surface. Cut these two surfaces so that the seating surface will have the specified width.

After cutting, lap the valve to properly match the valve and valve seat surfaces. Start off with coarse

Valve/Valve Seat Contact Area

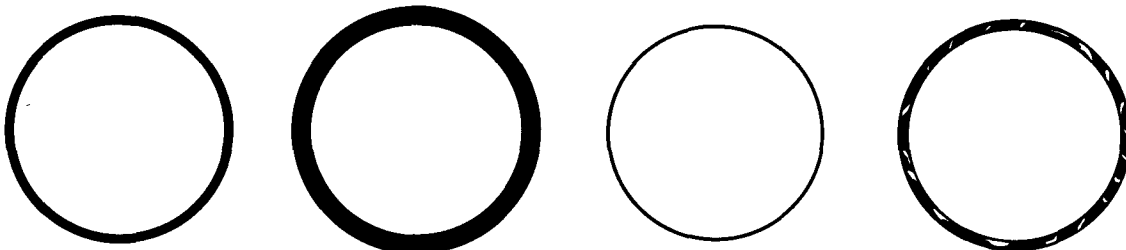

lapping compound, and finish with fine compound.

Apply compound to the valve seat, and tap the valve lightly into place while rotating it with a lapper. Repeat this until a smooth, matched surface is obtained.

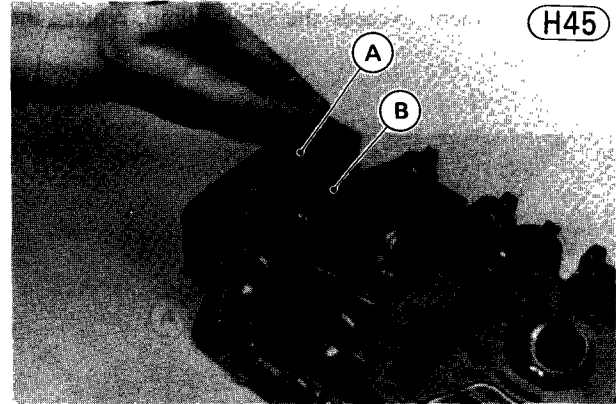

(H45)

A. Lapper

B. Valve

Valve stem height inspection

After grinding the valves or valve seats and before assembling the cylinder head, measure the installed valve height from the bottom of the cylinder head lifter hole to the end of the valve stem with a vernier caliper. Refer to Table H21 for the recommended repair.

Valve Installed Height

(H46)

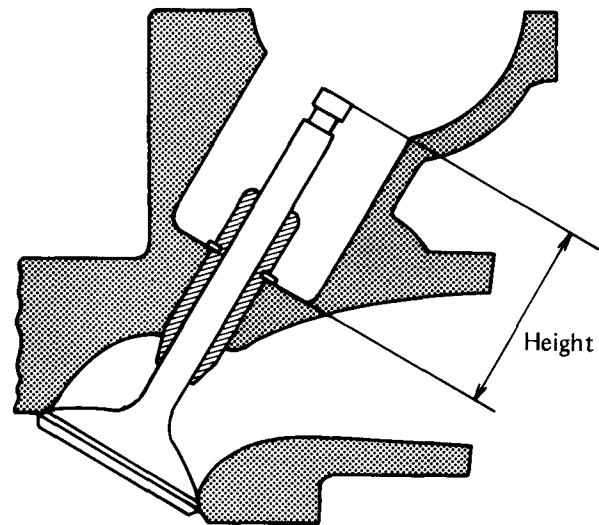

(H47)

Table H21 Valve Stem Installed Height Procedure

Measurement	Probable Cause	Recommendation	
		Assemble with this shim:	After checking valve clearance, final shim may be in this range:
36.60~36.64 mm	Normal/acceptable	2.85 mm	2.85~3.20 mm
36.65~36.69		2.80	2.80~3.20
36.70~36.74		2.75	2.75~3.15
36.75~36.79		2.70	2.70~3.10
36.80~36.84		2.65	2.65~3.05
36.85~36.89		2.60	2.60~3.00
36.90~36.94		2.55	2.55~2.95
36.95~36.99		2.50	2.50~2.90
37.00~37.04		2.45	2.45~2.85
37.05~37.09		2.40	2.40~2.80
37.10~37.14		2.35	2.35~2.75
37.15~37.19		2.30	2.30~2.70
37.20~37.24		2.25	2.25~2.65
37.25~37.29		2.20	2.20~2.60
37.30~37.34		2.15	2.15~2.55
37.35~37.39		2.10	2.10~2.50
37.40~37.44		2.05	2.05~2.45
37.45~37.49		2.00	2.00~2.40
37.50~37.54	2.00	2.00~2.35	
More than 37.54 mm	Valve face and valve seat worn out.	1. Replace valve. Remeasure. 2. Replace cylinder head. Remeasure.	

Be sure to mark each valve so it may be properly matched to its corresponding valve seat during assembly.

A selection of various thickness valve shims are available for adjusting the valve clearance. There is however, a limit to the amount of adjustment possible using the shims. Resurfacing of the valve face and valve seat inevitably drops the valve deeper into the valve seat, allowing the valve stem end to come closer to the camshaft. Consequently, a thinner shim must be used to compensate for the reduced valve clearance.

Over a period of long use and repeated resurfacing, the valve may drop so far into the valve seat. In this

thinnest shim cannot give adequate clearance, and it should be necessary to replace the valve and remeasure the installed height. If this is not successful, it will be necessary to replace the cylinder head. Replacement valve seats are not available.

Valve Spring

When the valve is not being pushed open by the cam the valve springs press the valve against the seat to prevent compression leakage. An inner spring is used

166 MAINTENANCE—ENGINE

may cause valve float at high rpm. If the springs weaken or break, compression leakage and valve noise will result, dropping engine power.

Spring tension

Remove the springs, and set them one at a time, on a spring tension testing device. Compress the spring, and read the tension at the test length. If the spring tension at the specified length is weaker than the service limit, replace the spring.

Valve Spring Tension Measurement

H48

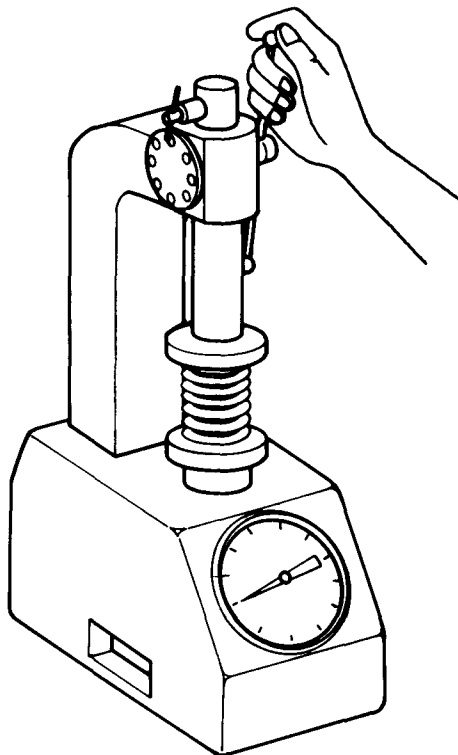

Table H22 Valve Spring Tension

Springs	Test Length	Service Limit
Inner	23.6 mm	15.6 kg
Outer	25.6 mm	28.5 kg

Spring Squareness

Measure the squareness of each spring by standing each end on a surface plate and setting a square against it. Replace any spring for which the distance between the top of the spring and the square is greater than the service limit.

Table H23 Valve Spring Squareness

Valve Spring Squareness

H49

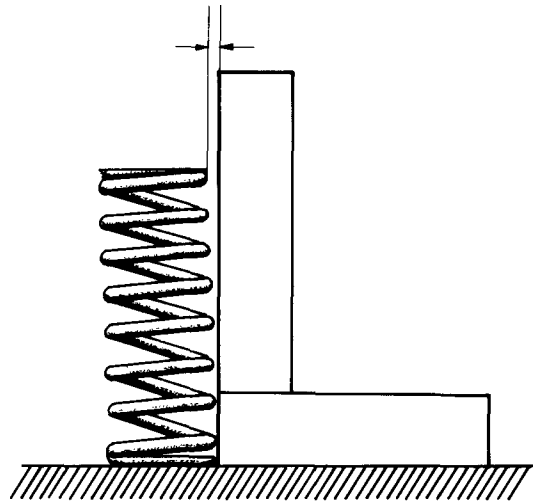

Oil Seal

The oil seal around each valve stem prevents oil from leaking down into the combustion chamber. If an oil seal is damaged or deteriorated, oil consumption will increase, and carbon may build up in the combustion chambers. This may be indicated by white exhaust smoke.

If an oil seal appears damaged or deteriorated or if there is any doubt as to its condition, replace it with a new one.

KAWASAKI CLEAN AIR SYSTEM (US model)

The motorcycle on US model adopts the air injection system for the clean air system.

The secondary air injection helps the fuel/air mixture burn more completely. Following the power stroke, the exhaust valve opens. As the burned fuel charge passes the exhaust valve, it is still hot enough to burn if air is supplied. By introducing a stream of fresh air into the hot exhaust gases just as they pass the exhaust valve, the burning is both intensified and prolonged. This increased burning action tends to burn up a great deal of the normally unburned gases, as well as changing a significant portion of the carbon monoxide into relatively harmless carbon dioxide.

The secondary air injection system consists of a vacuum switch valve, two air suction valves which have 2 each reeds, and air hoses. Without the use of an air pump, this system introduces fresh air into the exhaust system near the exhaust ports in response to pressure differentials generated by pulses in the exhaust.

Air Suction Valve

The air valve is essentially a check valve which allows

exhaust port. Any air that has passed the air suction valve is prevented from returning. Remove and inspect the air suction valves periodically (Pg. 10). Also, remove and inspect the air suction valves whenever the idle is unstable, engine power is greatly reduced, or there are abnormal engine noises.

Inspection

Visually inspect the reeds for cracks, folds, warping, heat damage, or other damage. If there is any doubt as to the condition of a reed, replace the air suction valve as an assembly.

Check the reed contact areas of the valve holder for grooves, scratches, any signs of separation from the holder, or heat damage. Check the sealing lip coating on the valve holder for the same signs. If there is any

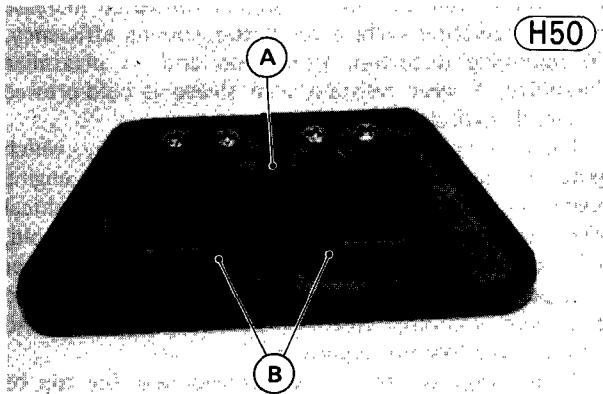

A. Valve Holder B. Reeds

Air Injection System

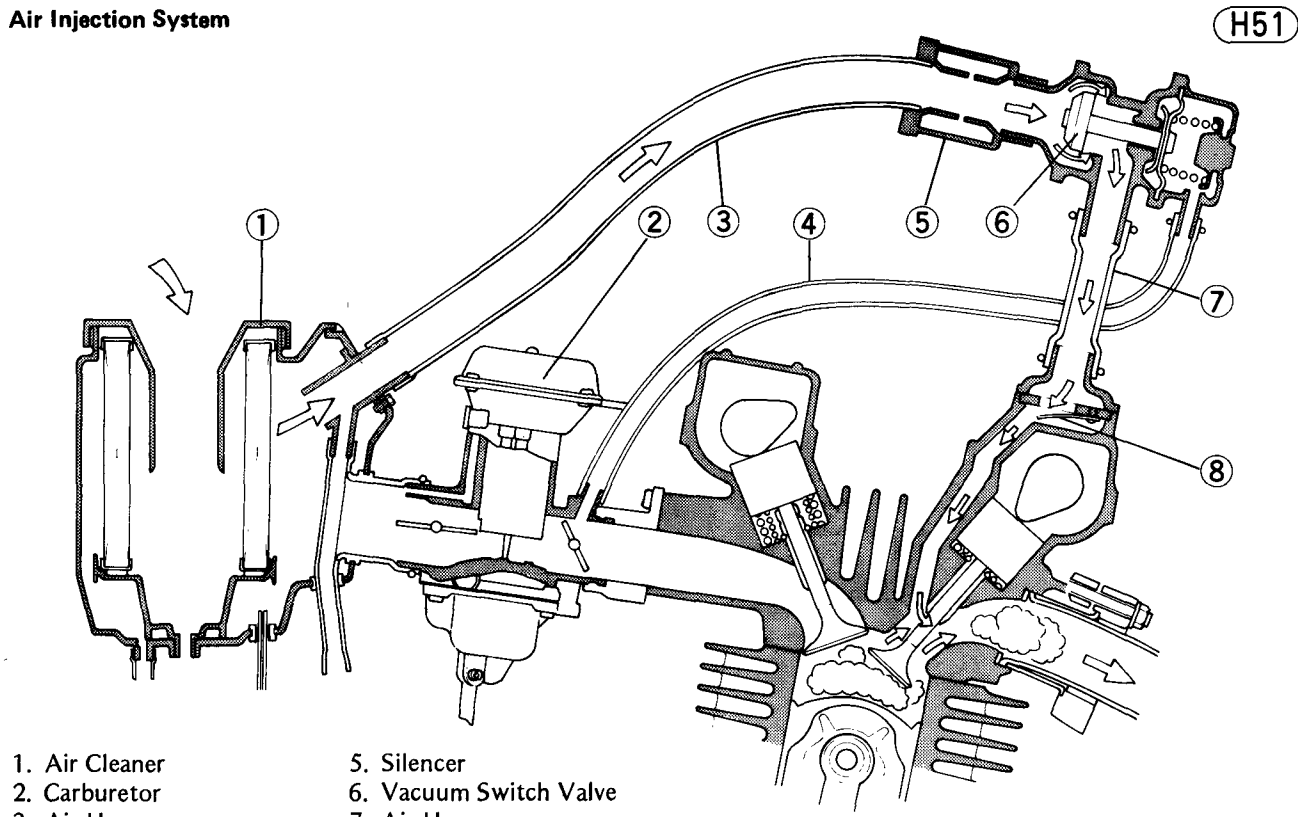

1. Air Cleaner 5. Silencer
 2. Carburetor 6. Vacuum Switch Valve
 7. ...
 8. ...

doubt as to the condition of the reed contact areas or the sealing lip, replace the air suction valve as an assembly.

If any carbon or other foreign particles have accumulated between the reed and the reed contact area, wash the valve assembly with a high flash-point solvent.

CAUTION Do not scrape off the deposits as this could damage the rubber, necessitating air suction valve assembly replacement.

Vacuum Switch Valve

Although the vacuum switch valve usually permits secondary air flow, it shuts off the air flow when a high vacuum (low pressure) is developed at the engine side of the carburetor bores during engine braking. This is to prevent explosions in the exhaust ports which might be caused by extra unburned fuel in the exhaust during deceleration, if fresh air were injected into the exhaust ports. These explosions or "backfiring" in the exhaust system could damage the air suction valves.

Regular inspection of the vacuum switch valve is not needed. If backfiring occurs frequently in the exhaust system during engine braking or if there are abnormal engine noises, check the vacuum switch valve as follows:

CAUTION Do not attempt to turn the paint-locked screw on the vacuum switch valve. This screw position is preset to determine spring preload. Turning the screw will cause valve malfunction.

Inspection

Be certain that all the hoses are routed without being flattened or kinked, and are connected correctly to the

168 MAINTENANCE—ENGINE

air cleaner housing, vacuum switch valve, #2 and #3 carburetor holders, and air suction covers. If they are not, correct them. Replace them if damaged.

Using the vacuum gauge (special tool) and a syringe, inspect the vacuum switch operation as follows:

- Remove the fuel tank.
- Pull the air hose out of the air cleaner housing.
- Slide the hose clamps out of place, and pull the vacuum hoses (2) off the carburetors.
- Connect the vacuum gauge and a syringe to the vacuum hoses.

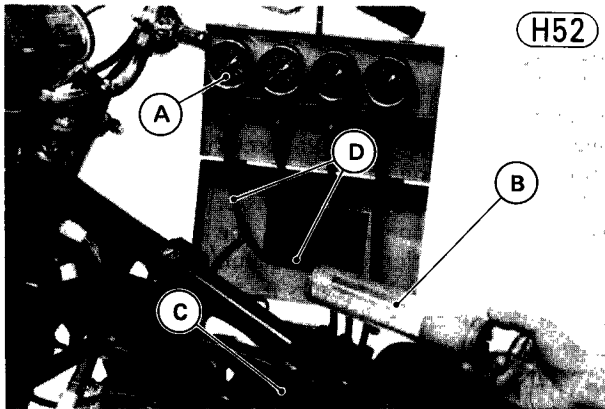

A. Vacuum Gauge (57001-127 or 226)
 B. Syringe C. Air Hose D. Vacuum Hoses

- Gradually raise the vacuum (lower the pressure) applied to the vacuum switch valve, and check the valve operation. When the vacuum is low enough, the vacuum switch valve should permit air to flow. When the vacuum reaches a certain level between 40 and 46 cmHg, it should stop air flow. When the vacuum is high enough, the air cannot also flow through the valve. If the vacuum switch valve does not operate as this, replace it with a new one. Adjustment is not permitted.

NOTE: Whether the valve permits the air to flow or not is confirmed by blowing the air hose with breath.

CAUTION Do not apply a vacuum more than 50 cmHg to the vacuum switch valve as this could damage the diaphragm in the valve.

Vacuum Switch Valve Operation

1. During Cruising

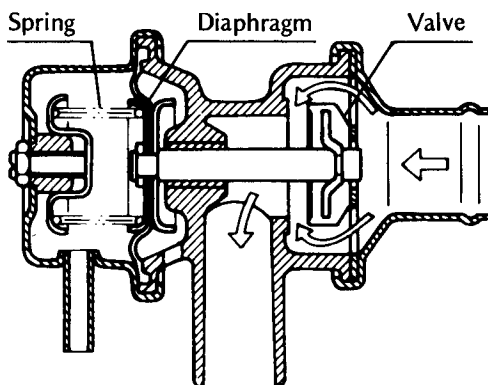

- Conversely, gradually lower the vacuum (raise the pressure) applied from the high vacuum, and check the valve operation. The valve will return to its original state just the reverse way as it came, but the transition should occur when the vacuum comes to a level between 40 and 46 cmHg. If the valve does not work as specified, replace the valve with a new one.

CYLINDER BLOCK, PISTON

The cylinder block is subjected to extremely high temperatures. Since excessive heat can seriously distort the shape of a cylinder or cause piston seizure, the cylinder block is made of aluminum alloy for good heat conduction and the outside is finned to increase the heat-radiating surface for better cooling efficiency. To minimize distortion from heat and to maximize durability, a wear resistant iron sleeve is cold-pressed into each cylinder.

Each piston is made from an aluminum alloy, which expands and distorts slightly from heat during engine operation. So that the piston will become cylindrical after heat expansion, it is designed such that, when cold, it is tapered in towards the head and is elliptical rather than perfectly round. The piston diameter is made so that there is enough clearance between the piston and cylinder to allow for expansion.

Three rings are fitted into grooves near the top of each piston to prevent compression leakage into the crankcase and to stop oil from getting up into the combustion chambers. The top two rings are compression rings, and the bottom ring is an oil ring.

A full floating type piston pin is used to connect each piston to its connecting rod. The middle part of the piston pin passes through the small end of the connecting rod, and a snap ring is fitted at each end of the piston pin in a groove to prevent the pin from coming out of the piston. Since the pin is the full floating type, a small amount of clearance exists between the piston pin and the piston when the engine is at normal operating temperatures.

H53

2. During Engine Braking

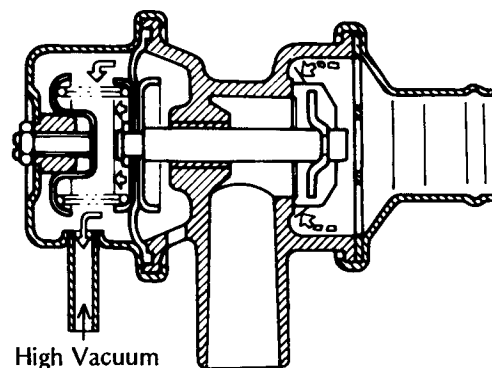

Proper inspection and maintenance of the cylinder block and the pistons include checking the compression; removing carbon from the piston heads, piston ring grooves, and cylinder head exhaust ports; and checking for wear and proper clearances during top end overhaul. A worn cylinder, worn piston, or worn or stuck piston rings may cause a loss of compression from gas blowby past the rings. Blowby may result in difficult starting, power loss, excessive fuel consumption, contaminated engine oil, and possibly engine destruction. Oil leakage into the combustion chambers causes carbon to build up on top of the pistons, which may result in preignition, overheating, and detonation. A worn piston pin causes piston rattle, which may cause accelerated piston and cylinder wear. It is evidenced by a knocking sound in the engine.

Engine problems may be caused not only by carbon deposits and wear or damage to the engine itself, but also by poor quality fuel or oil, improper oil, improper fuel/air mixture, improper oil supply, or incorrect ignition timing. Whenever knocking, pinging, piston rattle, or other abnormal engine noise is heard; the cause should be determined as soon as possible. Neglect of proper maintenance will result in wear, overheating, detonation, piston seizure, or engine destruction.

Compression measurement

A compression test is useful in determining the condition of the engine. Low compression may be due to cylinder wear; worn piston ring grooves; worn, broken, or sticking piston rings; poor valve seating; cylinder head leaks; or damage to the engine such as piston seizure. Too high compression may be due to carbon build-up on the piston heads and cylinder head. Difference in compression between the cylinders may cause poor running.

Before measuring compression, check that the cylinder head is tightened down with the specified torque (Pg. 36) and that the battery is fully charged (Pg. 219), and thoroughly warm up the engine so that engine oil between the pistons and cylinder walls will help seal compression as it does during normal running. While the engine is running, check that there is no gas leakage from around the cylinder head gasket and from the spark plugs.

Stop the engine, remove all spark plugs, and screw the compression gauge (special tool) firmly into one spark plug hole. Using the starter motor, turn the engine over with the throttle fully open until the compression gauge stops rising; the compression is the highest reading obtainable. Repeat the measurement for the other cylinder.

Table H24 Cylinder Compression †

Usable Range	8.7 ~ 13.4 kg/cm ² (124 ~ 191 psi), less than 1 kg/cm ² (14 psi) difference between any two cylinders
--------------	---

† Engine hot, spark plugs removed, throttle fully

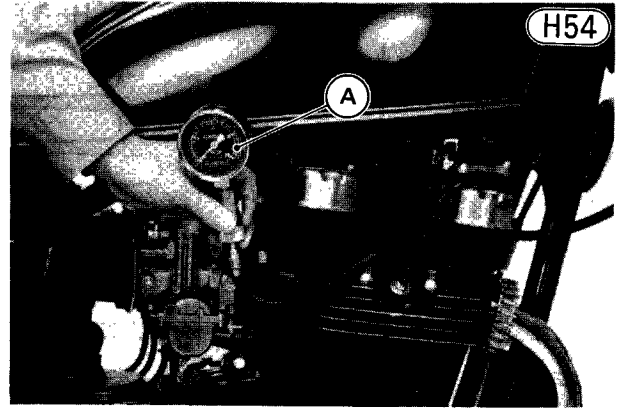

A. Compression Gauge (57001-123)

If cylinder compression is higher than the standard value, check the following:

1. Carbon build-up on the piston head and cylinder head — clean off any carbon on the piston head and cylinder head.
2. Cylinder head gasket, cylinder base gasket — use only the proper gaskets for the cylinder head and base. The use of gaskets of the incorrect thickness will change the compression.
3. Valve stem oil seals and piston rings — rapid carbon accumulation in the combustion chambers may be caused by damaged valve stem oil seals and/or damaged piston oil rings. This may be indicated by white exhaust smoke.
4. Cylinder head volume (Pg. 160).

If cylinder compression is lower than the service limit, check the following:

1. Gas leakage around the cylinder head — replace the damaged gasket and check the cylinder head for warp (Pg. 160).
2. Condition of the valve seating (Pg. 163).
3. Valve clearance — if a valve requires an unusually thick shim to obtain proper clearance, the valve may be bent, and not seating completely.
4. Piston/cylinder clearance, piston seizure.
5. Piston ring, piston ring groove.

Cylinder, piston wear

Since there is a difference in cylinder wear in different directions, take a side-to-side and a front-to-back measurement at each of the 3 locations (total of 6 measurements) shown in Fig. H55. If any of the cylinder inside diameter measurements exceeds the service limit, the cylinder will have to be bored oversize and then honed. However, if the amount of boring necessary would make the inside diameter greater than 67.0 mm, the cylinder block must be replaced.

Table H25 Cylinder Inside Diameter

Service Limit
66.10 mm, or more than 0.05 mm difference between any two measurements

170 MAINTENANCE—ENGINE

Cylinder Inside Diameter Measurement

H55

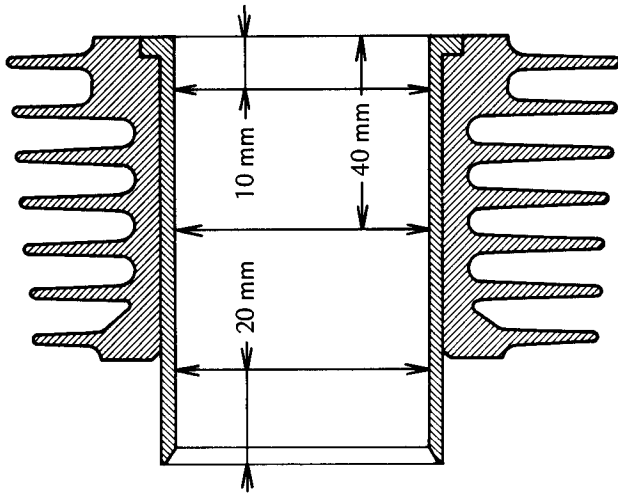

Measure the outside diameter of each piston 5 mm up from the bottom of the piston at a right angle to the direction of the piston pin. If the measurement is under the service limit, replace the piston.

NOTE: Abnormal wear such as a marked diagonal pattern across the piston skirt may mean a bent connecting rod or crankshaft.

H56

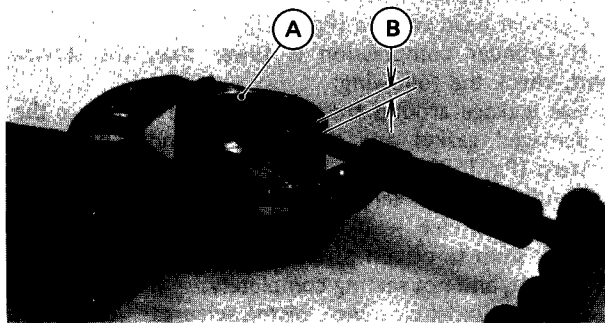

A. Piston B. 5 mm

Table H26 Piston Diameter

Service Limit	65.80 mm
---------------	----------

Table H25 applies only to cylinder that has no been bored oversize, and Table H26 applies only to the standard size piston.

NOTE: Whenever the piston or cylinder block has been replaced with a new one, the motorcycle must be broken in the same as with a new machine.

Piston/cylinder clearance

The piston-to-cylinder clearance is measured whenever a piston or the cylinder block is replaced with a new one, or whenever a cylinder is rebored and an

clearance must be adhered to whenever the cylinder block is replaced or a cylinder rebored. If only a piston is replaced, the clearance may exceed the standard slightly. But it must not be less than the minimum, in order to avoid piston seizure.

The most accurate way to find the piston clearance is by making separate piston and cylinder diameter measurements and then computing the difference between the two values. Measure the piston diameter as just described, and measure the cylinder diameter at the very bottom of the cylinder.

Table H27 Piston/Cylinder Clearance

Standard	0.040 ~ 0.067 mm
----------	------------------

Boring, honing

When boring and honing a cylinder, note the following:

1. Before boring a cylinder, first measure the exact diameter of the oversize piston, and then in accordance with the standard clearance given in Table H27, determine the diameter of the rebore.
2. Never separate the liners from the cylinder when boring and honing the liners, because the top surface of cylinder and liners is machined at the factory as an assembly to get the proper surface.
3. To avoid cylinder distortion due to unbalanced metal temperatures, bore the cylinders in 2-4-1-3 or 3-1-4-2 order.
4. Cylinder inside diameter must not vary more than 0.01 mm at any point.
5. Be wary of measurements taken immediately after boring since the heat affects cylinder diameter.
6. There are two sizes of oversize pistons available: 0.5 mm and 1.0 mm. Oversize pistons require oversize rings.
7. In the case of a rebored cylinder and oversize piston, the service limit for the cylinder is the diameter to which the cylinder was bored plus 0.1 mm, the service limit for the piston is the oversize piston original diameter minus 0.15 mm. If the exact figure for the rebored diameter is unknown, it can be roughly determined by measuring the diameter at the base of the cylinder.

Piston/cylinder seizure

Remove the cylinder block and pistons to check the damage. If there is only slight damage, the piston may be smoothed with #400 emery cloth, and any aluminum deposits removed from the cylinder with either #400 emery cloth or light honing. However, in most cases, the cylinder will have to be bored oversize and honed, and an oversize piston installed.

Piston cleaning

Built-up carbon on the piston head reduces the cooling capability of the piston and raises compression, leading to overheating which could possibly even melt the top of the piston. To decarbonize the piston head, remove the piston (Pg. 62), scrape off the carbon, and



Carbon accumulated in the piston ring grooves can cause the rings to stick. Remove the rings, and clean out any carbon deposits using the end of a broken piston ring or some other suitable tool.

- CAUTION**
1. When removing carbon, take care not to scratch the side of the piston, or the piston ring grooves.
 2. Never clean the piston heads with the engine assembled. If the carbon is scraped from the piston heads with the cylinder left in place, carbon particles will unavoidably drop between the pistons and cylinder walls and eventually find their way into the crank chamber. Carbon particles, which are very abrasive, drastically shorten the life of the rings, pistons, cylinders, crankshaft bearings, and oil seals.

Piston ring, piston ring groove wear

Visually inspect the piston rings and the piston ring grooves. If the rings are worn unevenly or damaged, they must be replaced. If the piston ring grooves are worn unevenly or damaged, the piston must be replaced and fitted with new rings. The two rails and the expander of the oil ring must be replaced as a set.

With the top and second rings in their grooves, make several measurements with a thickness gauge to determine piston ring/groove clearance. If the clearance exceeds the service limit, measure the thickness of the piston rings and the width of the ring grooves. If the ring has worn down to less than the service limit, replace the ring; if the groove width exceeds the service limit, replace the piston.

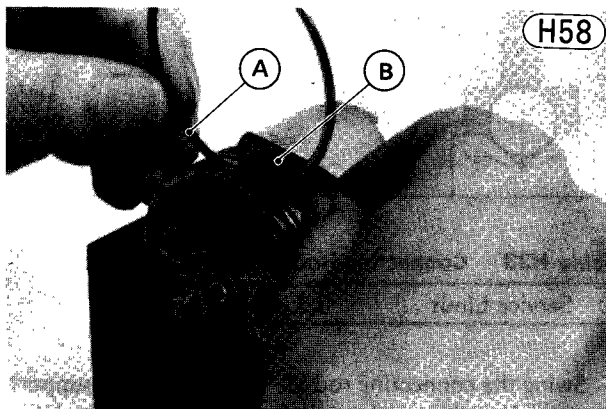

Table H28 Piston Ring/Groove Clearance

	Service Limit
Top and 2nd	0.15 mm

Table H29 Piston Ring Thickness

	Service Limit
Top and 2nd	1.40 mm

Table H30 Piston Ring Groove Width

	Service Limit
Top and 2nd	1.60 mm
Oil	2.60 mm

When new rings are being fitted into a used piston, check for uneven groove wear by inspecting the ring seating. The rings should fit perfectly parallel to the groove surfaces. If not, the piston must be replaced.

Piston ring end gap (top, second)

Place the piston ring inside the cylinder, using the piston to locate the ring squarely in place. Set it close to the bottom of the cylinder, where cylinder wear is low. Measure the gap between the ends of the ring with a thickness gauge. If the gap is wider than the service limit, the ring is overworn and must be replaced.

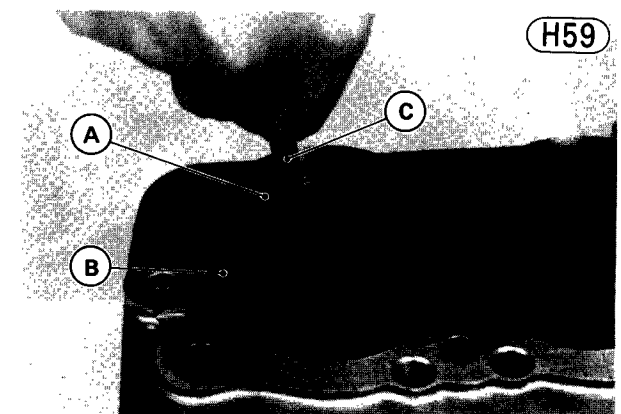

A. Piston Ring **C. Thickness Gauge**
B. Cylinder Block

Table H31 Ring End Gap

	Service Limit
Top and 2nd	0.7 mm

NOTE: The service limit is effective also for the bored

172 MAINTENANCE—ENGINE

Piston, piston pin, connecting rod wear

Measure the diameter of the piston pin with a micrometer, and measure the inside diameter of both piston pin holes in the piston. If the piston pin diameter is less than the service limit at any point, replace the piston pin. If either piston pin hole diameter exceeds the service limit, replace the piston.

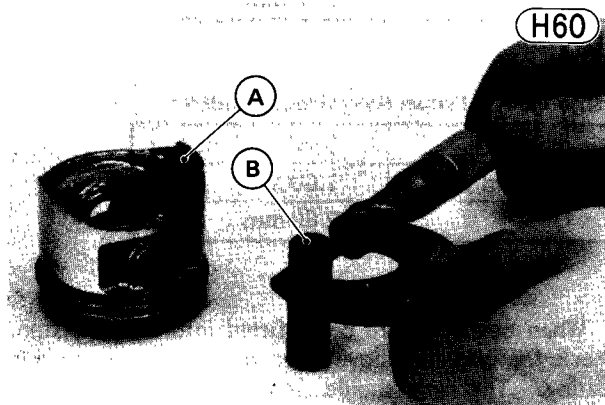

A. Piston **B. Piston Pin**

Measure the inside diameter of the connecting rod small end. If the diameter exceeds the service limit, replace the connecting rod.

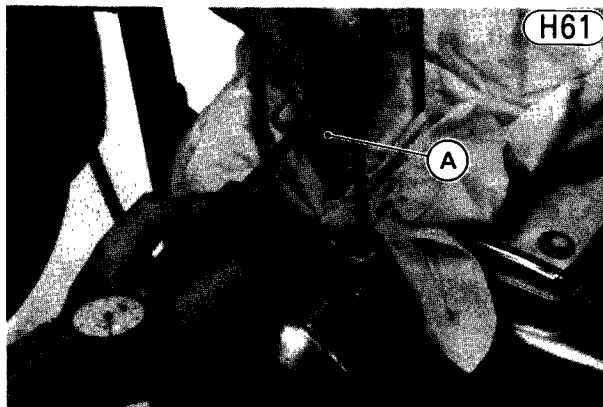

A. Connecting Rod

Table H32 Piston Pin, Pin Hole, Small End Diameter

	Service Limit
Piston Pin	14.96 mm
Piston Pin Hole	15.07 mm
Small End	15.05 mm

NOTE: When a new piston or pin is used, also check that piston-to-pin clearance is 0.006 ~ 0.015 mm, and that pin to small end clearance is within 0.005 ~ 0.020

CRANKSHAFT, CONNECTING ROD

The crankshaft changes the reciprocating motion of the pistons into rotating motion, which is transmitted to the rear wheel when the clutch is engaged. The connecting rods connect the pistons to the crankshaft. Crankshaft or connecting rod trouble, such as worn crankshaft journals or a bent connecting rod, will multiply the stress caused by the intermittent force on the pistons. This results in not only rapid crankshaft bearing wear, but also noise, power loss, vibration, and shortened engine life. A defective crankshaft or connecting rod should always be detected at an early stage and then replaced immediately.

The following explanation concerns the most common crankshaft and connecting rod problems, giving the procedure for detecting damage and measuring wear and runout.

Connecting rod bend, twist

Remove the connecting rod big end bearing inserts and replace the connecting rod big end cap. Select an arbor of the same diameter as the connecting rod big end and of optional length, and insert it through the big end of the connecting rod. Select an arbor of the same diameter as the piston pin and of optional length, and insert it through the small end of the connecting rod.

On a surface plate, set the big-end arbor on V blocks so that the connecting rod is perpendicular to the surface plate. Using a height gauge or dial gauge, measure the difference in the height of the small-end arbor above the surface plate over a 100 mm length to determine the amount the connecting rod is bent. If the measurement exceeds the service limit, replace the connecting rod.

Connecting Rod Bend Measurement

H62

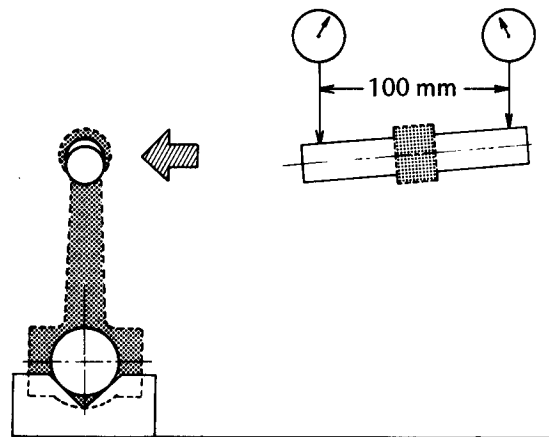

Table H33 Connecting Rod Bend/100 mm

Service Limit	0.2 mm
---------------	--------

Swing the connecting rod 90° to one side and support it parallel to the surface plate as shown in Fig. H63.

arbor above the surface plate over a 100 mm length to determine the amount the connecting rod is twisted.

If the measurement exceeds the service limit, replace the connecting rod.

Connecting Rod Twist Measurement

H63

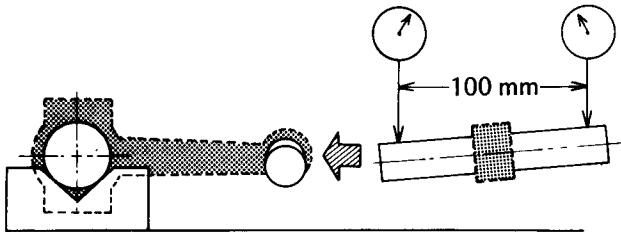

Table H34 Connecting Rod Twist/100 mm

Service Limit	0.2 mm
---------------	--------

Connecting rod bearing insert/journal wear

Bearing insert wear is measured using a plastigauge (press gauge), which is inserted into the clearance to be measured. The plastigauge indicates the clearance by the amount it is compressed and widened when the parts are assembled.

Remove the connecting rods. Cut strips of plastigauge to bearing insert width. Place a strip on the connecting rod bearing insert on each connecting rod parallel to the crankshaft so the plastigauge will be compressed between the bearing insert and the connecting rod journal. Install the connecting rods, tightening the nuts with the specified torque (Pg. 36).

Remove the connecting rods, and measure the plastigauge width to determine the bearing insert/journal wear.

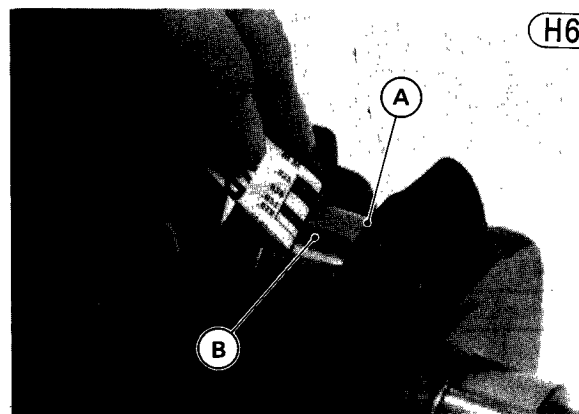

H64

A. Crankshaft B. Plastigauge

Table H35 Connecting Rod Bearing Insert/Journal Clearance

--	--

If the clearance exceeds the service limit, replace the bearing inserts as follows:

1. With a micrometer, measure the diameter of the crankshaft journals on which the connecting rods fit. Mark each flywheel in accordance with the journal diameter (Table H36).

If the measurements is less than the service limit, replace the crankshaft.

If the measurements is less than the standard value, but is not under the service limit; use bearing inserts painted green.

NOTE: Any mark already on the flywheel should not be referred to during servicing.

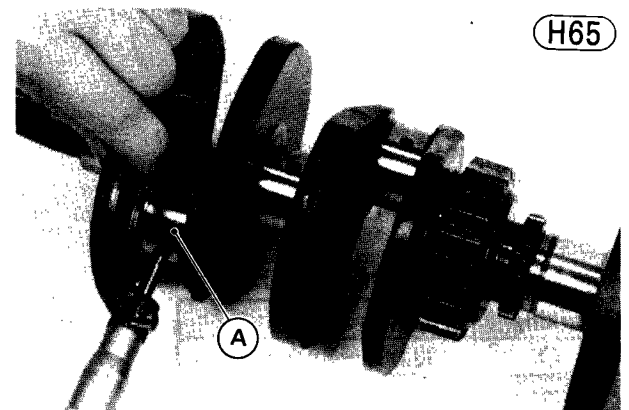

H65

A. Connecting Rod Journal

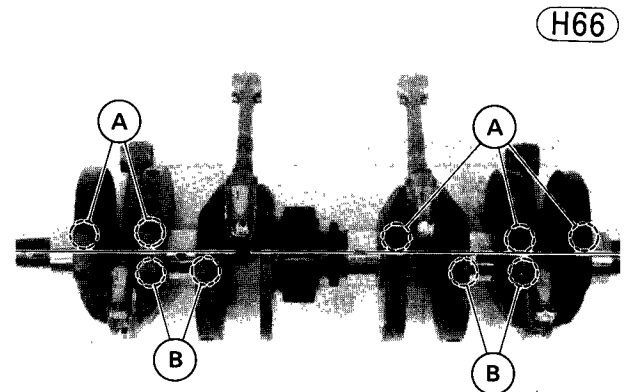

H66

**A. Marking for Crankshaft Journal Diameter
B. Marking for Connecting Rod Journal Diameter ("O" or No mark)**

Table H36 Connecting Rod Journal Diameter

Marking	Standard	Service Limit
No mark	34.984~34.994 mm	34.97 mm
○	34.995~35.000 mm	

2. Put the connecting rod big end caps on the rods and tighten the nuts with the specified torque (Pg.

174 MAINTENANCE—ENGINE

connecting rod big end in accordance with the inside diameter (Table H37).

NOTE: The mark already on the big end should almost coincide with the measurement.

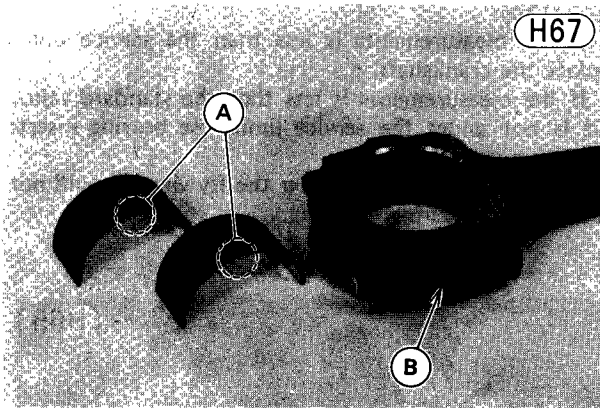

- A. Painted Marks (Green, Black, or Brown)
- B. Marking for Connecting Rod Inside Diameter ("O" or No mark)

Table H37 Connecting Rod Big End Diameter

Marking	Standard
○	38.009 ~ 38.016 mm
No mark	38.000 ~ 38.008 mm

3. Select the proper bearing insert in accordance with the combination of the connecting rod and crankshaft coding.

Table H38 Bearing Insert Selection

Crankshaft Marking \ Con-Rod Marking	○	No mark
	○	Black P/N: 13034-051
No mark	Green P/N: 13034-050	Black P/N: 13034-051

Table H39 Bearing Insert Thickness

Color	Thickness
Green	1.485 ~ 1.490 mm
Black	1.480 ~ 1.485 mm
Brown	1.475 ~ 1.480 mm

Connecting rod side clearance

Measure the side clearance of the connecting rod

and the connecting rod if the clearance exceeds the service limit.

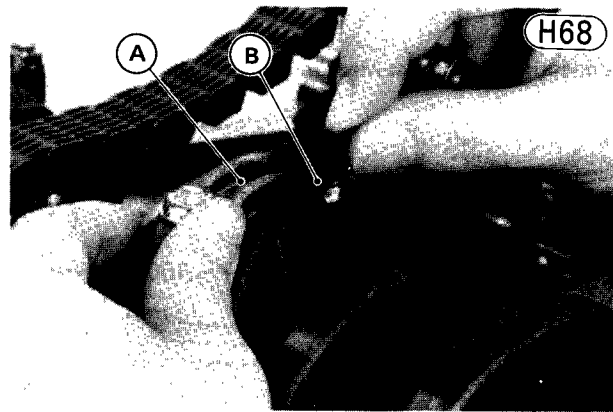

- A. Connecting Rod
- B. Thickness Gauge

Table H40 Connecting Rod Big End Side Clearance

Service Limit	0.45 mm
---------------	---------

Crankshaft runout

Set the crankshaft in a flywheel alignment jig or on V blocks, and place a dial gauge against the points indicated. Turn the crankshaft slowly. The maximum difference in gauge readings is the crankshaft runout.

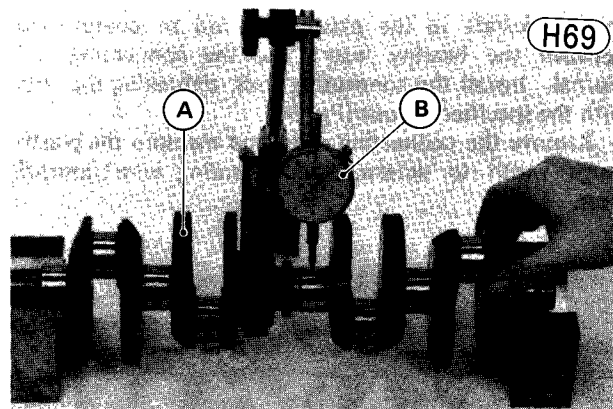

- A. Crankshaft
- B. Dial Gauge

Table H41 Crankshaft Runout

Service Limit	0.05 mm
---------------	---------

Crankshaft bearing insert/journal wear

Remove the crankshaft. Clean off the oil, and install the crankshaft. Cut strips of plastigauge to bearing insert width. Place a strip on each journal parallel to the crankshaft so the plastigauge will be compressed between the insert and the crankshaft journal. Install

and tighten the bolts in the correct sequence with the specified amount of torque (Pg. 36).

Remove the lower crankcase half (making sure that the crankshaft does not turn at any time), and measure the plastigauge width to determine the bearing insert/journal wear.

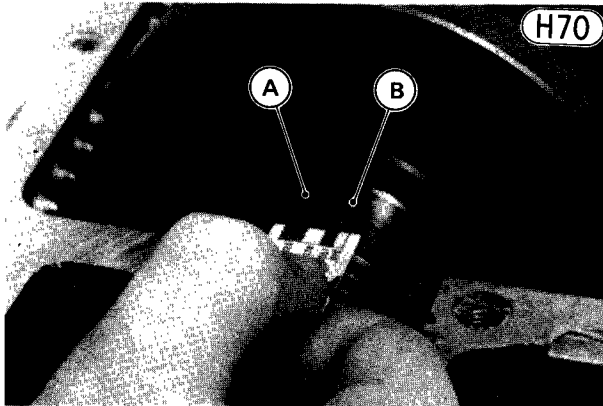

A. Crankshaft B. Plastigauge

Table H42 Crankshaft Bearing Insert/Journal Clearance

Service Limit	0.11 mm
---------------	---------

If any clearance exceeds the service limit, replace all bearing inserts (10) as follows:

1. Measure the diameter of the crankshaft journals which wear on these bearing inserts. Mark each fly-wheel in accordance with the journal diameter (Table H43).

If the measurements is less than the service limit, replace the crankshaft.

If the measurements is less than the standard value, but is not under the service limit; use bearing inserts painted blue.

NOTE: Any mark already on the flywheel should not be referred to during servicing.

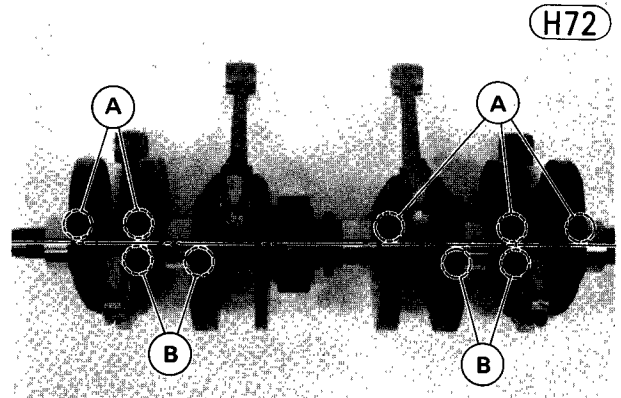
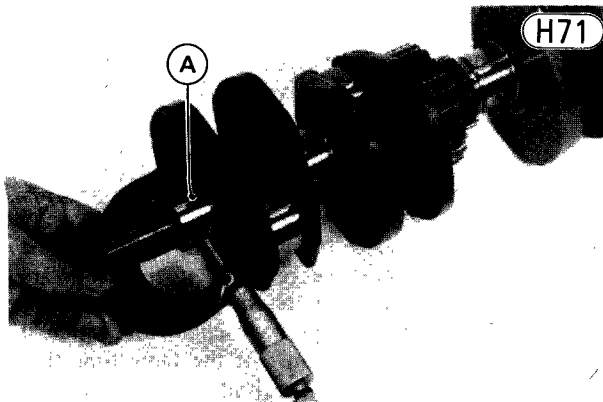

A. Marking for Crankshaft Journal Diameter ("1" or No mark)

B. Marking for Connecting Rod Journal Diameter

Table H43 Crankshaft Journal Diameter

Marking	Standard	Service Limit
No mark	35.984~35.991 mm	35.96 mm
1	35.992~36.000 mm	

2. Put the lower crankcase half on the upper crankcase half without the bearing inserts, and tighten the bolts to the specified torque (Pg. 36). Measure the inside diameter, and mark the upper crankcase half in accordance with the inside diameter (Table H44).

NOTE: The mark already on the upper crankcase half should almost coincide with the measurement.

Crankcase Marking (Upper Crankcase)

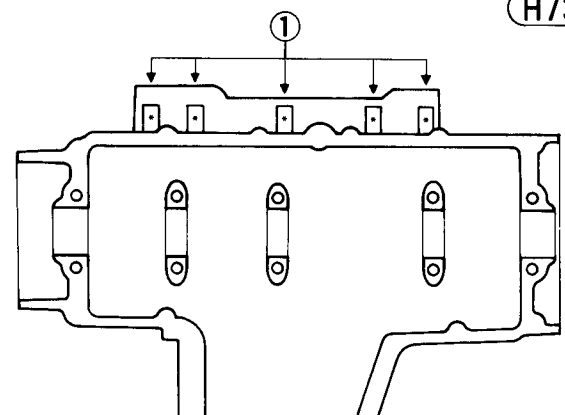

1. Crankcase Markings ("O" or No mark)

Table H44 Crankshaft Bearing Inside Diameter

Marking	Standard
○	39.000 ~ 39.008 mm
No mark	39.009 ~ 39.016 mm

3. Select the proper bearing inserts in accordance with the combination of the crankcase and the crankshaft

176 MAINTENANCE—ENGINE

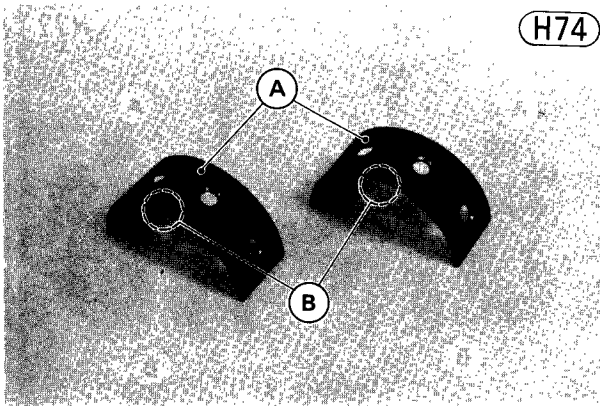

- A. Bearing Inserts
- B. Painted Marks (Brown, Black, or Blue)

Table H45 Crankshaft Bearing Insert Selection

Crankcase Marking \ Crankshaft Marking	○	No mark
	1	Brown P/N: 92028-1102
No mark	Black P/N: 92028-1101	Blue P/N: 92028-1100

Table H46 Crankshaft Bearing Insert Thickness

Color	Thickness
Brown	1.490 ~ 1.494 mm
Black	1.494 ~ 1.498 mm
Blue	1.498 ~ 1.502 mm

Crankshaft side clearance

Measure the crankshaft side clearance with a thickness gauge as shown. Replace the crankcase halves as a set, if the clearance exceeds the service limit.

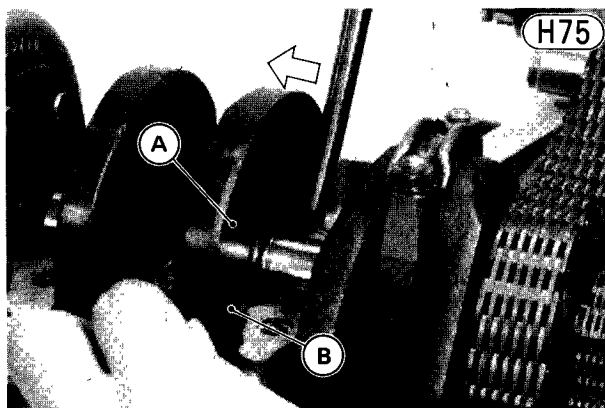

- A. Crankshaft
- B. Thickness Gauge

Table H47 Crankshaft Side Clearance

NOTE: The upper crankcase half and the lower crankcase half are machined at the factory in the assembled state, so the crankcase halves must be replaced as a set.

Oil passage cleaning

There are oil passages running between the crankshaft journals. Use compressed air to remove any foreign particles or residue that may have accumulated in these passages.

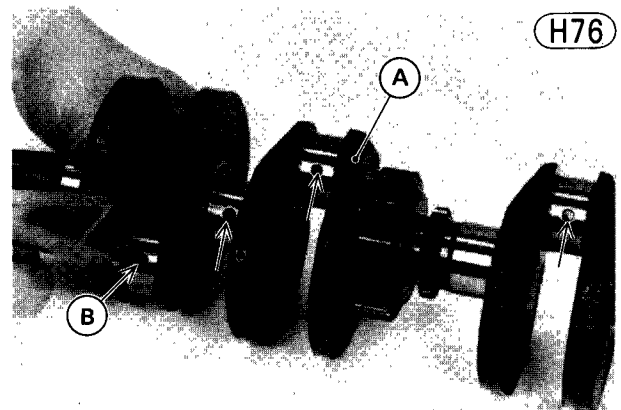

- A. Crankshaft
- B. Compressed Air

SECONDARY SHAFT

The secondary shaft has the secondary sprocket, coupling, starter motor clutch, and secondary shaft gear on it. The secondary sprocket is chain-driven by the crankshaft, and the secondary shaft gear transmits the power to the clutch housing gear. The secondary shaft coupling connects the secondary sprocket to the shaft. Rubber dampers in the coupling absorb the pulsations of the engine torque.

Check both of the end ball bearings of the secondary shaft, and replace if necessary (Pg. 190).

Secondary sprocket damage

Inspect the teeth on the secondary sprocket. Any light damage can be corrected with an oilstone, but the secondary sprocket must be replaced if the teeth are badly damaged. Damaged teeth on the secondary sprocket indicate that the primary chain, by which it is driven, may also be damaged. At the same time that the secondary sprocket is repaired or replaced, the primary chain should be inspected and then replaced.

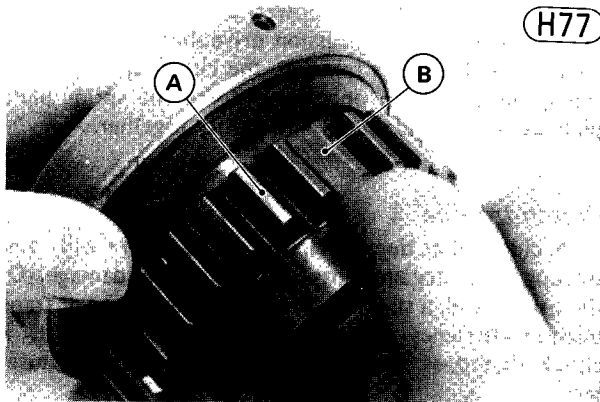

H77

A. Secondary Sprocket B. Oilstone

PRIMARY CHAIN

The power transmission from the crankshaft to the secondary shaft is chain-driven, utilizing a Hy-Vo (high velocity) chain. The Hy-Vo chain is a rocker-joint type with a pin and rocker construction. Some of the special features of the Hy-Vo chain are its capacity to transmit much power at high speed, its resistance to heat seizure due to a construction which employs rolling rather than sliding friction, quiet operation even at high rpm, and low power loss.

Wear

A primary chain which has worn so that it is 1.4% or more longer than when new is no longer safe for use and should be replaced. To inspect the chain wear by measuring the chain slack, remove the oil pan.

Measure the chain slack, and replace the chain if it has worn past the service limit. The replacement chain must be a Tsubakimoto Hy-Vo 3/8P-1W, 76 links chain.

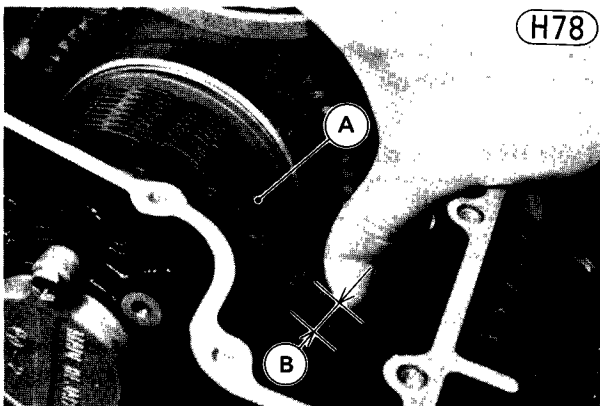

H78

Table H48 Primary Chain Play

Service Limit	27 mm
---------------	-------

CLUTCH

Fig. H79 shows the construction of the clutch, which is a wet, multi-plate type with 7 friction plates (19) and 6 steel plates (18). The friction plates are made of cork used for its high coefficient of friction, bonded on an aluminum core, which provides durability and warp resistance. The clutch housing (8) has a reduction gear (7) on one side and contains rubber dampers (3) to absorb shock from the drive train.

Clutch

H79

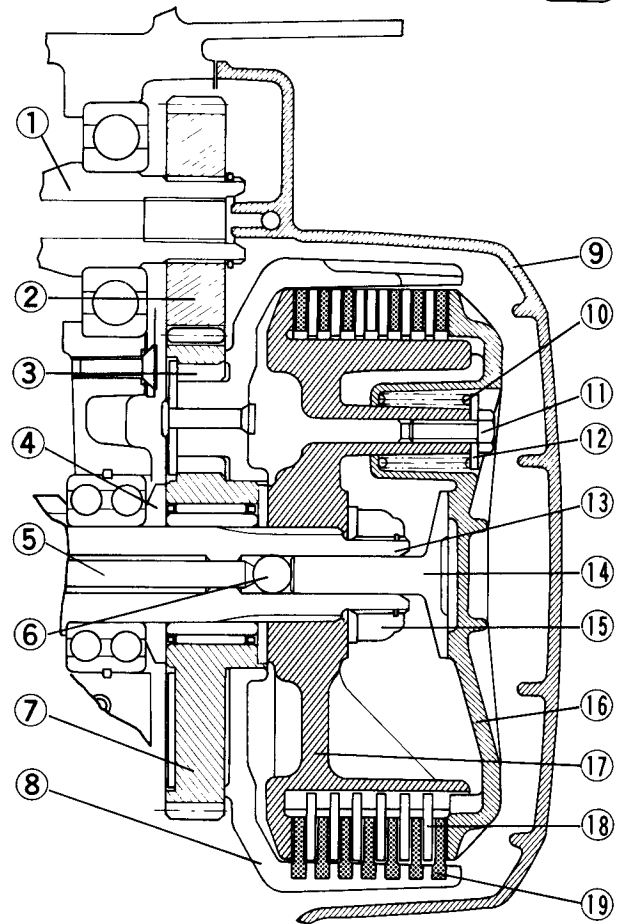

- | | |
|-------------------------|-------------------------|
| 1. Secondary Shaft | 10. Clutch Spring |
| 2. Secondary Shaft Gear | 11. Spring Bolt |
| 3. Rubber Damper | 12. Washer |
| 4. Spacer | 13. Drive Shaft |
| 5. Push Rod | 14. Spring Plate Pusher |
| 6. Steel Ball | 15. Clutch Hub Nut |
| 7. Clutch Housing Gear | 16. Spring Plate |
| 8. Clutch Housing | 17. Clutch Hub |
| | 18. Steel Plate |
| | 19. Friction Plate |

178 MAINTENANCE—ENGINE

The clutch release mechanism is shown in Fig. H80. The clutch release outer release gear ⑤ and the inner release gear ⑫ are made of steel. Balls ④ are installed between the outer and inner release gears to reduce the friction between them. Assembled into the center of the inner release gear is the clutch adjusting screw ②, which pushes on the push rod ⑪ and steel ball inside the drive shaft to release the clutch.

Clutch Release

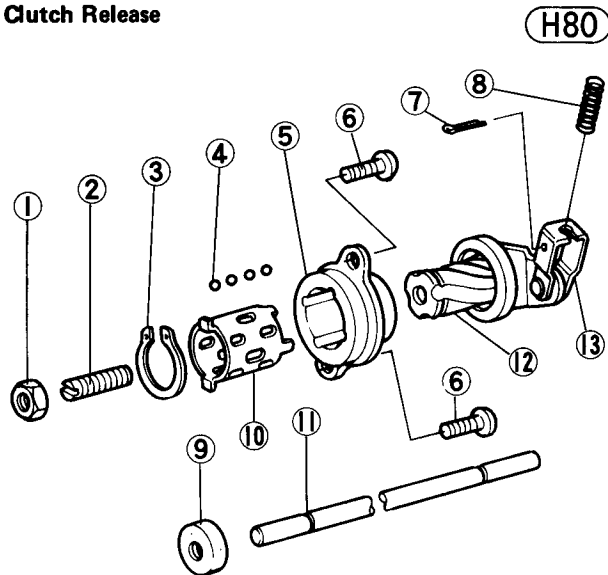

- | | |
|------------------------|------------------------|
| 1. Locknut | 8. Spring |
| 2. Adjusting Screw | 9. Oil Seal |
| 3. Circlip | 10. Retainer |
| 4. Steel Ball | 11. Push Rod |
| 5. Output Release Gear | 12. Inner Release Gear |
| 6. Mounting Screw | 13. Release Lever |
| 7. Cotter Pin | |

The friction plates are keyed to the clutch housing by tangs on the outer circumference of each plate. Since the clutch housing is gear-driven from the secondary shaft, these plates are always turning any time the engine is running. The steel plates have a toothed inner circumference and mesh with the splines in the clutch hub. The hub is mounted on the drive shaft, so that the drive shaft and steel plates always turn together.

One end of each clutch spring pushes against its washer and bolt, which is threaded into the clutch hub. The other end pushes against the spring plate. When the clutch is left engaged, the springs force the spring plate, friction plates, steel plates, and clutch hub tightly together so that the friction plates will drive the steel plates and transmit power to the transmission drive shaft.

When the clutch lever is pulled to release (disengage) the clutch, the clutch cable turns the clutch release inner release gear in, towards the clutch. The clutch adjusting screw, assembled inside the clutch release inner release gear, then pushes the push rod, which (through the steel ball and spring plate pusher) pushes the spring plate. Since the spring plate moves the same distance that the inner release gear moves and the clutch hub remains stationary, the springs are compressed and pressure is

longer pressed together, power transmission from the crankshaft to the transmission drive shaft is interrupted. As the clutch lever is released, the clutch springs return the spring plate and once again force the spring plate, plate assembly, and clutch hub tightly together.

Clutch trouble

A clutch that does not properly disengage will cause shifting difficulty and possible transmission damage. On the other hand, a slipping clutch will reduce power transmission efficiency and may overheat and burn out. A clutch that does not properly disengage may be caused by:

1. Excessive clutch lever play.
2. Clutch plates that are warped or too rough.
3. Uneven clutch spring tension.
4. Deteriorated engine oil.
5. Engine oil viscosity too high.
6. Engine oil level too high.
7. The clutch housing frozen on the drive shaft.
8. A defective clutch release mechanism.
9. An unevenly worn clutch hub or housing.
10. Missing parts.

A slipping clutch may be caused by:

1. No clutch lever play.
2. Worn friction plates.
3. Weak clutch springs.
4. The clutch cable not sliding smoothly.
5. A defective clutch release mechanism.
6. An unevenly worn clutch hub or housing.

Clutch noise may be caused by:

1. Too much backlash between the secondary shaft gear and the clutch gear.
2. Damaged gear teeth.
3. Too much clearance between the friction plate tangs and the clutch housing.
4. Needle bearing worn or damaged.
5. Weak or damaged damper rubber(s).
6. Metal chips jammed into the clutch housing gear teeth.

Spring tension

Remove the clutch springs, and set them, one at a time, on a spring tension testing device. Compress the spring, and read the tension at the test length. If the spring tension at the specified length is weaker than the service limit, replace the spring.

Table H49 Clutch Spring Tension

Test Length	Service Limit
24.1 mm	23.5 kg

Friction plate wear, damage

Visually inspect the friction plates to see whether or not they show any signs of seizure, overheating, or uneven wear. Measure the thickness of the plates with vernier calipers.

If any plates show signs of damage, or if they have worn past the service limit, replace them with new ones.

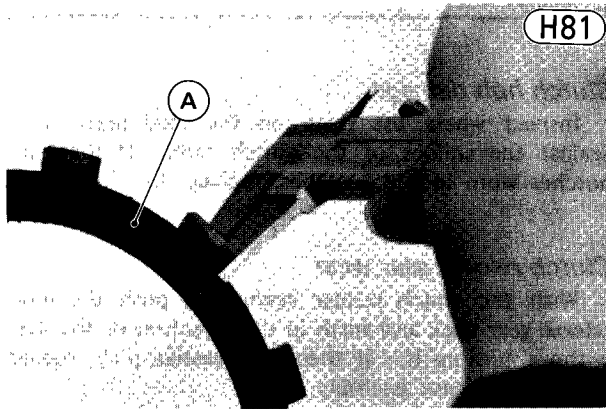

A. Friction Plate

Friction Plate Measurement

H82

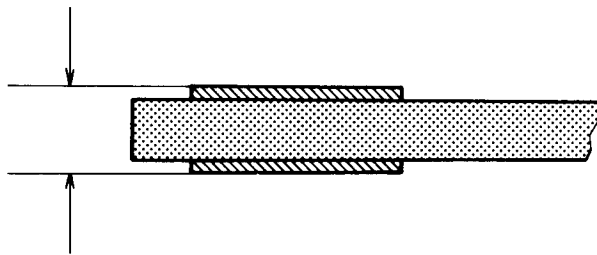

Table H50 Friction Plate Thickness

Service Limit	3.5 mm
---------------	--------

Clutch plate warp

Place each clutch plate on a surface plate, and measure the gap between each clutch plate and the surface plate. This gap is the amount of clutch plate warp.

Replace any plates warped over the service limit.

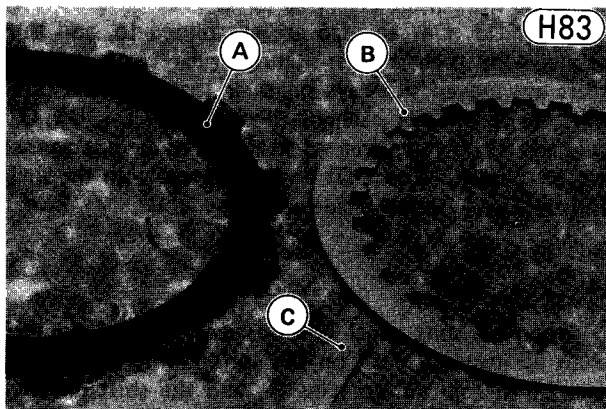

A. Friction Plate

B. Steel Plate

C. Thickness Gauge

Table H51 Clutch Plate Warp

Service Limit	0.4 mm
---------------	--------

Friction plate/clutch housing clearance

Measure the clearance between the tangs on the friction plates and the fingers of the clutch housing. If this clearance is excessive, the clutch will be noisy.

If the clearance exceeds the service limit, replace the friction plates. Also, replace the clutch housing if it is unevenly or badly worn where the friction plates wear against it.

Friction Plate/Clutch Housing Clearance

H84

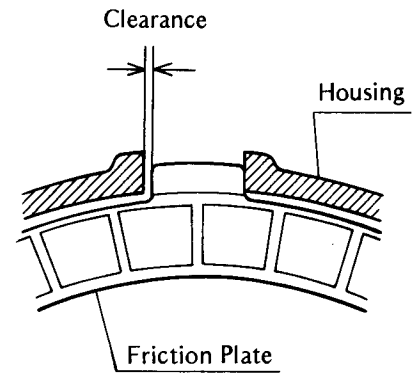

Table H52 Friction Plate/Clutch Housing Clearance

Service Limit	1.0 mm
---------------	--------

Inspect the fingers of the housing where the tang of the friction plates hit them. If they are badly worn or if there are grooves cut where the tangs hit, replace the clutch housing.

Clutch housing gear damage

Inspect the teeth on the clutch housing gear. Any light damage can be corrected with an oilstone, but the clutch housing must be replaced if the teeth are badly damaged. Damaged teeth on the clutch housing gear indicate that the secondary shaft gear, by which it is driven, may also be damaged. Whenever the clutch housing gear is repaired or replaced, the secondary shaft gear should be inspected, and then replaced if necessary.

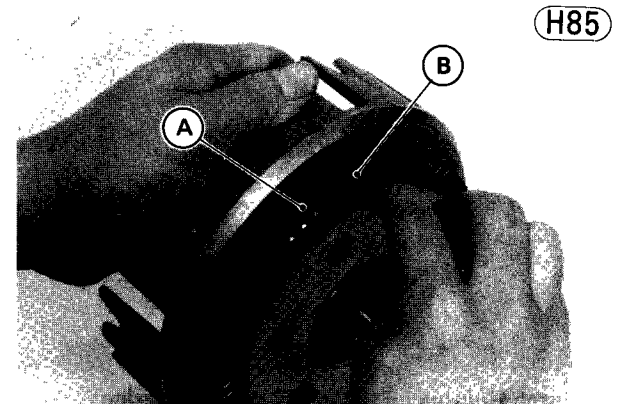

180 MAINTENANCE—ENGINE

Clutch housing gear/secondary shaft gear backlash

Measure the backlash between the clutch housing gear and secondary shaft gear. To measure the backlash, set a dial gauge against the teeth of one gear. Then move the gear back and forth while holding the other gear steady. The difference between the highest and the lowest gauge reading is the amount of backlash. Replace both the clutch housing and the secondary shaft gear wherever the amount of backlash exceeds the service limit.

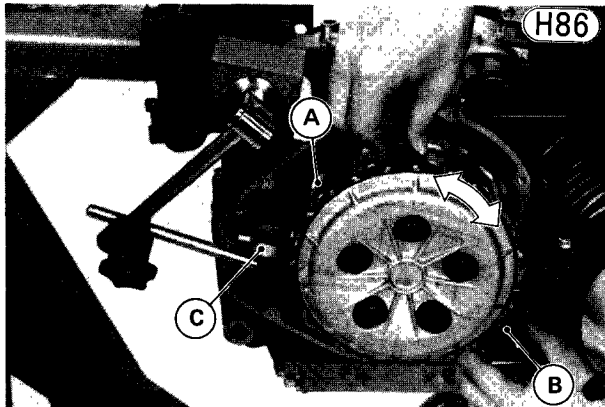

A. Clutch Housing
B. Secondary Shaft Gear
C. Dial Gauge

Table H53 Clutch Housing Gear/Secondary Shaft Gear Backlash

Service Limit	0.12 mm
---------------	---------

Clutch housing/drive shaft sleeve wear

Measure the diameter of the drive shaft sleeve with a micrometer. Replace the drive shaft sleeve if the diameter is less than the service limit. Measure the inside diameter of the clutch housing with a cylinder gauge. Replace the clutch housing if the diameter exceeds the service limit. Check the clutch housing needle bearing (Pg. 190). When replacing the clutch housing and/or drive shaft sleeve, replace the clutch housing needle bearing also.

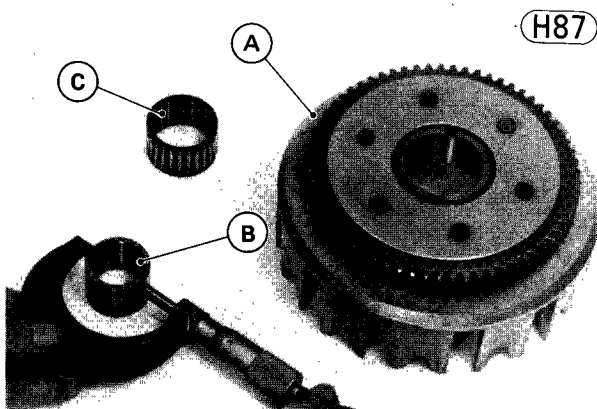

A. Clutch Housing
B. Dial Indicator
C. Needle Bearing

Table H54 Clutch Housing, Sleeve Diameter

	Clutch Housing	Sleeve
Service Limit	37.03 mm	31.96 mm

Clutch hub damage

Inspect where the teeth on the steel plates wear against the splines of the clutch hub. If there are notches worn into the splines, replace the clutch hub.

Clutch release gear wear

With the clutch release assembled, push the inner release gear back and forth in the direction of the shaft without turning it. If there is excessive play, replace the clutch release assembly.

Lubrication

Lubricate the clutch release gear with grease.

TRANSMISSION

The transmission is a 5-speed, constant mesh, return shift type. Its cross section is shown in Fig. H88, and the external shift mechanism is shown in Fig. H89. For simplicity, the drive shaft gears in the following explanation are referred to as "D" (e.g., D1=drive shaft 1st gear) and the output shaft gear as "O".

Gears D3, O4, and O5 are all splined to, and thus rotate with their shafts. During gear changes, these gears are moved sideways on their shafts by the three shift forks, one for each of them. Gears D4, D5, O1, O2, and O3 rotate free of shaft rotation, but cannot move sideways. Gears D1 and D2 rotate with the shaft and are unable to move sideways.

Shift Mechanism

When the shift pedal ④ is raised or lowered, the shift shaft ① turns, a pawl on the shift arm ⑤ catches on one of the shift drum pins ⑧, and the shift drum ⑨ turns. At the same time, the overshift limiter ② on the shift lever ③ catches another pin as shown in Fig. H89. As the shift drum turns, the shift fork guide pins (3), each riding in a groove in the shift drum, change the position of one or another of the shift forks ①,

Transmission

H88

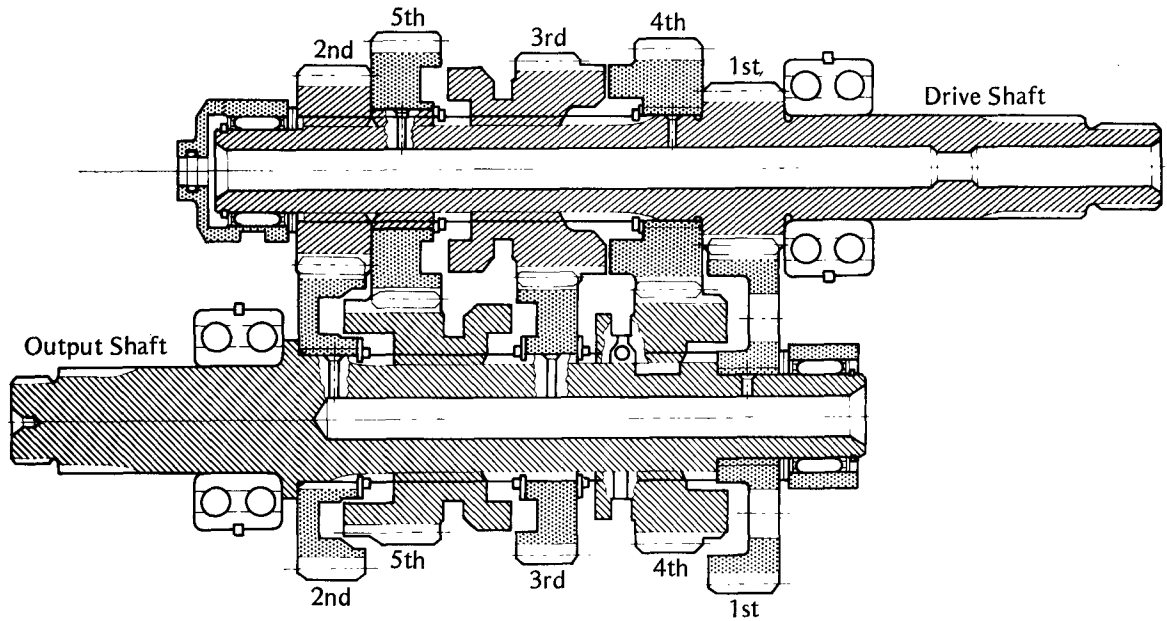

Shift Mechanism

H89

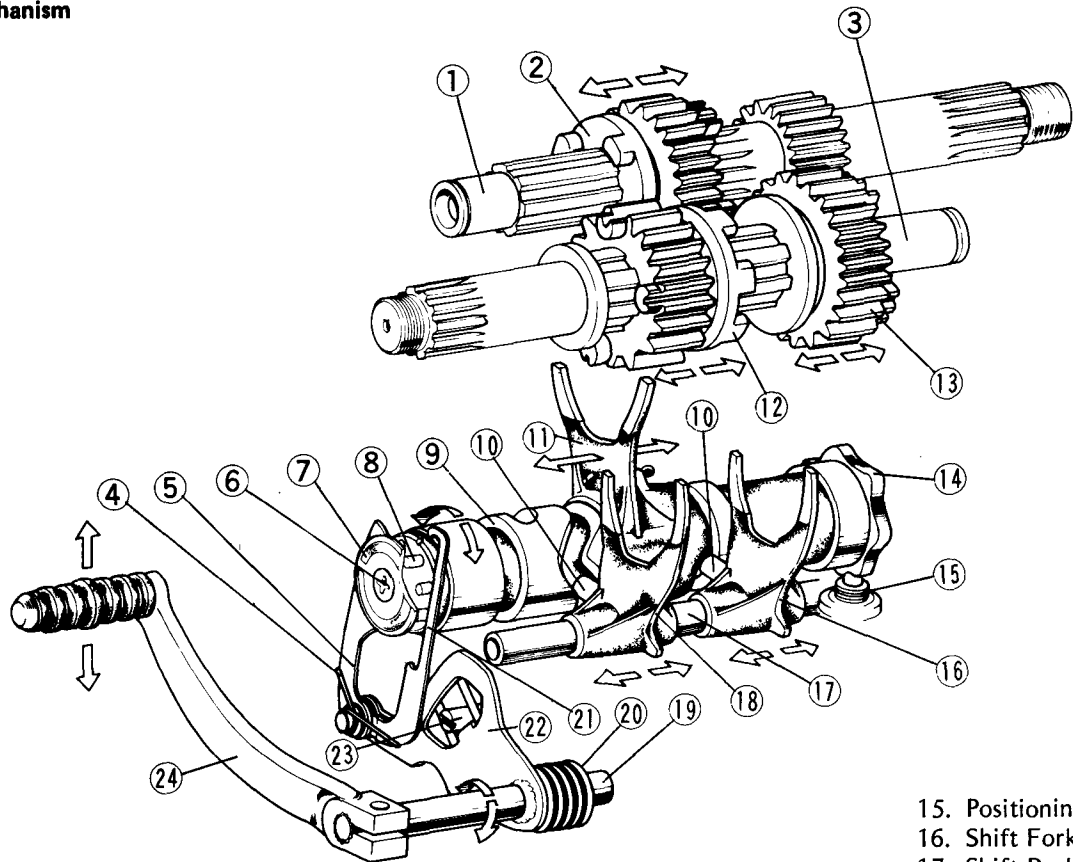

- 1. Drive Shaft
- 2. Drive 3rd Gear
- 3. Output Shaft
- 4. Pawl Spring
- 5. Shift Arm
- 6. Screw

- 8. Shift Drum Pin
- 9. Shift Drum
- 10. Guide Pin
- 11. Shift Fork (4th/5th)
- 12. Output 5th Gear
- 13. Output 4th Gear

- 15. Positioning Pin
- 16. Shift Fork (1st)
- 17. Shift Rod
- 18. Shift Fork (2nd/3rd)
- 19. Shift Shaft
- 20. Return Spring
- 21. Overshift Limiter
- 22. Shift Lever
- 23. Return Spring Pin

182 MAINTENANCE—ENGINE

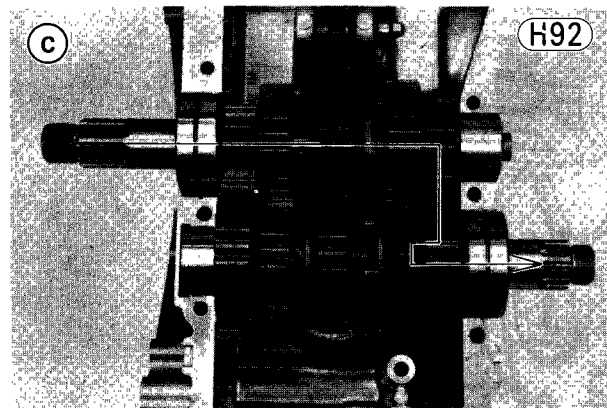
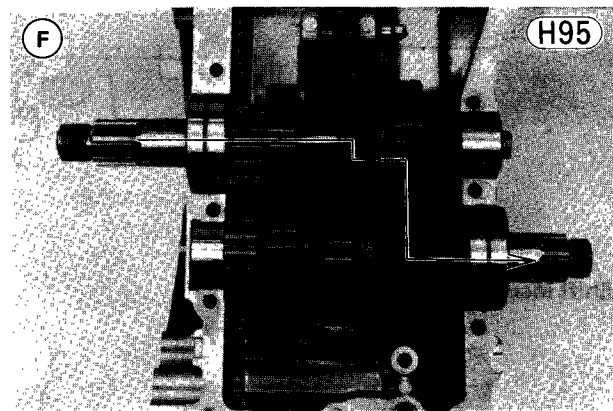
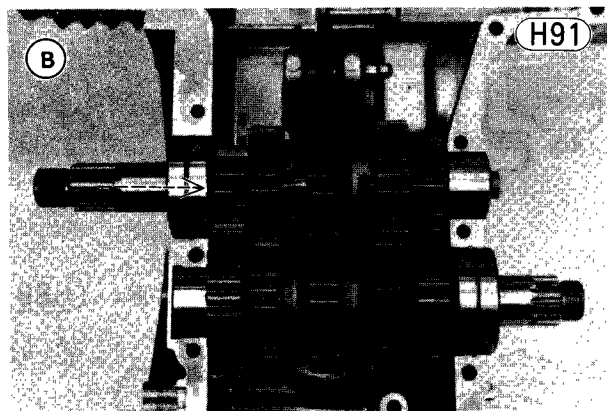
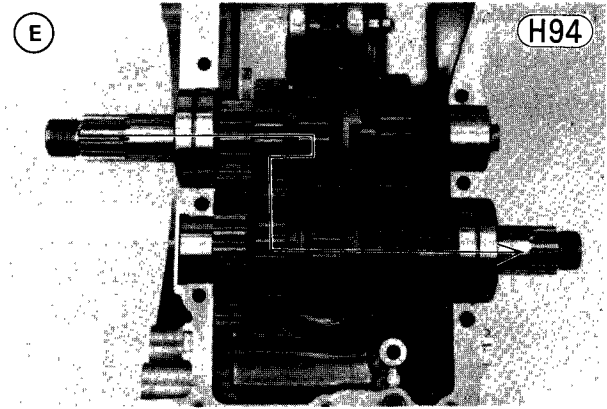
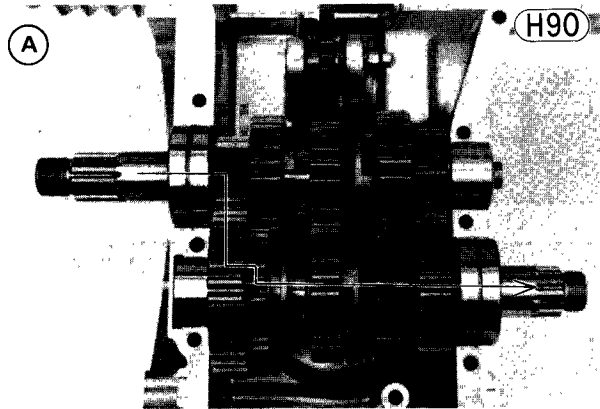

A. 1st
B. Neutral
C. 2nd
D. 3rd
E. 4th
F. 5th

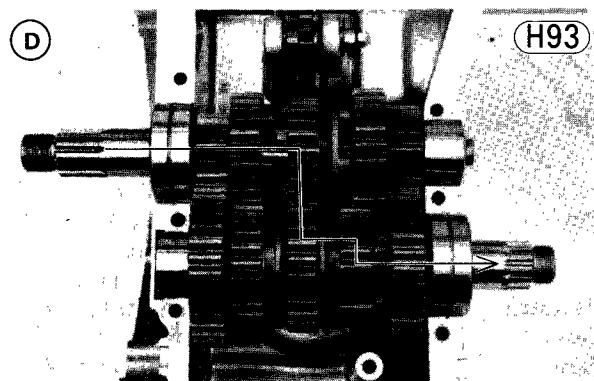

The shift fork ears then determine the position of gears D3 ②, O4 ⑬, and O5 ⑫. Refer to Fig. H90 through H95 for the gear position and drive path for neutral and each of the 5 gears. An arm spring ④ is fitted on the external shift mechanism to keep the shift arm and overshift limiter pressed against the shift drum pins to ensure proper pawl and pin contact. When the shift pedal is released after shifting, the return spring ⑳ returns the shift lever and shift pedal to their original positions. So that the transmission will remain where it was shifted, the shift drum positioning pin ⑮ pushes the shift drum positioning pin ⑮ into one of six notches on the shift drum operating plate ⑭. Five of these notches are equally spaced and correspond to the 5 gears. The other notch is halfway between the notches for 1st and 2nd gears, and corresponds to the half-stroke shift pedal movement from 1st or 2nd gear required to shift into neutral.

The return spring pin ㉓ on the side of the crankcase passes through a cutout on the shift mechanism lever. This pin engages between the two ends of the shift mechanism return spring. Normally, the return spring pin should not make contact with the cutout on the lever, because the overshift limiter is the primary con-

Neutral Locator

Inside gear O4 three steel balls are located 120° apart, and serve to facilitate neutral location when shifting from first gear. When the motorcycle is stopped and the output shaft is not turning, one or two of these balls falls down into its respective groove in the output shaft. When the shift pedal is operated to shift from first toward second, gear O4 starts moving, but halfway toward its second gear position, the steel ball(s) hits the end of the groove(s) in the output shaft, stopping gear O4 from moving, stopping the shift drum from turning, and leaving the transmission gears in the neutral position.

Neutral Locator

(H96)

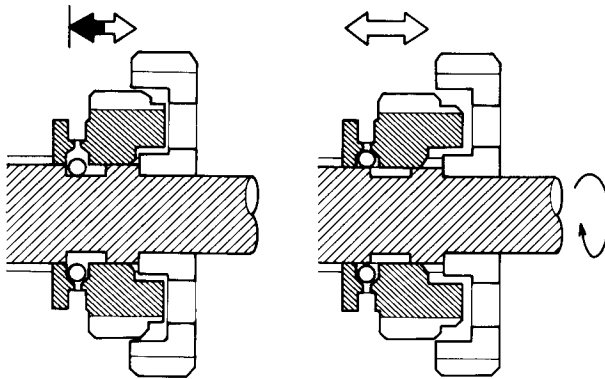

Overshift Limiter

Each time that the shift pedal is operated, the overshift limiter interlocks with the shift drum pins to prevent overshifting. On a full upshift or downshift stroke, the limiter “hooks” catch the shift drum pins to keep the

inertia of the heavy shift drum from allowing it to rotate beyond the intended gear position, particularly on a fast shift. At the same time, the overshift limiter arrests the shift lever’s motion at the end of the stroke to aid in preventing overshifting.

Transmission trouble

Transmission or external shift mechanism damage, causing the transmission to misshift, overshift, and/or jump out of gear, can cause further damage to the transmission and overrev damage to the engine itself. An improperly functioning transmission or external shift mechanism may be caused by the following:

1. Loose return spring pin
2. Broken or weakened return spring or shift drum positioning pin spring
3. Broken or weakened shift pawl spring
4. Damaged shift arm and/or overshift limiter
5. Loose shift drum guide bolt
6. Bent or worn shift fork(s)
7. Worn shift fork grooves on gears D3, O4 and/or O5
8. Worn shift fork guide pin(s)
9. Worn shift drum groove(s)
10. Binding of shift drum positioning pin in the positioning bolt
11. Worn or damaged gear dogs, gear dog holes, and/or gear dog recesses
12. Improperly functioning clutch or clutch release
13. Improper assembly or missing parts

Transmission noise results from worn or damaged shafts, bearings, gear hubs or teeth, etc.

External shift mechanism inspection

Inspect the shift pawl spring, shift pawls, and return spring. Replace any broken or other wise damaged parts.

Shift Arm and Overshift Limiter Operation

(H97)

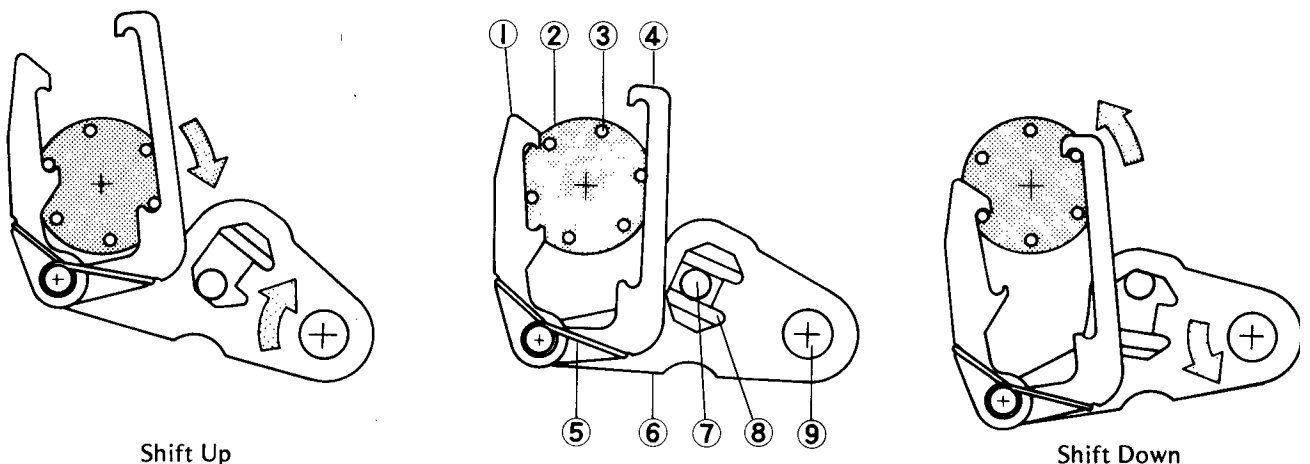

1. Shift Arm
2. Shift Drum

4. Overshift Limiter
5. Pawl Spring

7. Return Spring Pin
8. Return Spring

H98

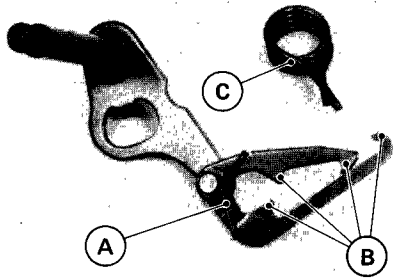

A. Pawl Spring
B. Shift Pawls
C. Return Spring

Measure the free length of the shift drum positioning pin spring. If it is shorter than the service limit, replace it with a new one.

H99

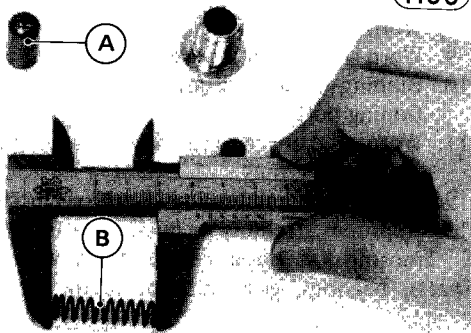

A. Positioning Pin
B. Pin Spring

Table H55 Positioning Pin Spring Length

Service Limit	30.7 mm
---------------	---------

Check to see if the return spring pin is loose. If it is, remove it and apply a non-permanent locking agent to the threads, and then screw it back in.

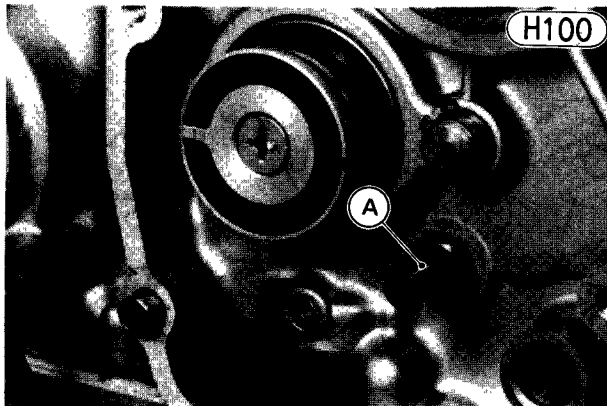

A. Return Spring Pin

Gear backlash

Split the crankcase. Leaving the transmission in place, measure the backlash between gears O1 and D1, O2 and D2, O3 and D3, O4 and D4, O5 and D5. To measure the backlash, set a dial gauge against the teeth on one gear. Then move the gear back and forth while holding the other gear steady. The difference between the highest and the lowest gauge reading is the amount of backlash. Replace both gears if the amount of backlash exceeds the service limit.

H101

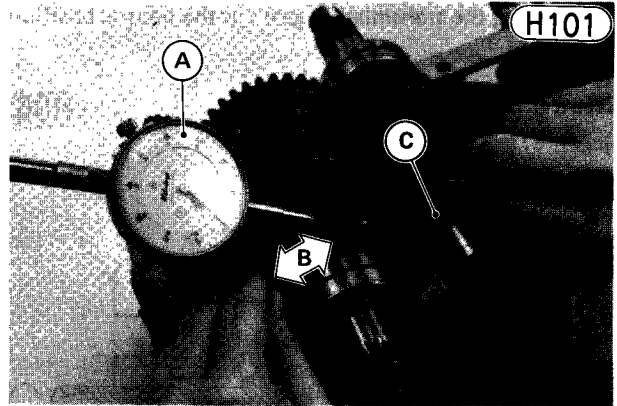

A. Dial Gauge
B. Move
C. Hold

Table H56 Gear Backlash

Service Limit	0.25 mm
---------------	---------

Shift fork bending

Visually inspect the shift forks, and replace any fork that is bent. A bent fork could cause difficulty in shifting or allow the transmission to jump out of gear when under power.

Shift fork/gear groove wear

Measure the thickness of the ears of each shift fork, and measure the width of the shift fork grooves on gears D3, O4 and O5. If the thickness of a shift fork ear is under the service limit, the shift fork must be replaced. If a gear shift fork groove is worn over the service limit, the gear must be replaced.

H102

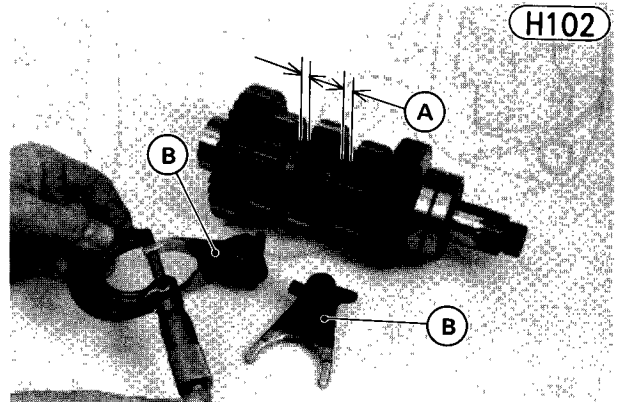

A. Gear Shift Fork Grooves
B. Shift Fork

Table H57 Shift Fork Thickness

Service Limit	4.7 mm
---------------	--------

Table H58 Gear Shift Fork Groove Width

Service Limit	5.25 mm
---------------	---------

Shift fork guide pin/shift drum groove wear

Measure the diameter of each shift fork guide pin, and measure the width of each shift drum groove. Replace any shift fork on which the guide pin has worn past the service limit. If a shift drum groove is worn past the service limit, replace the shift drum.

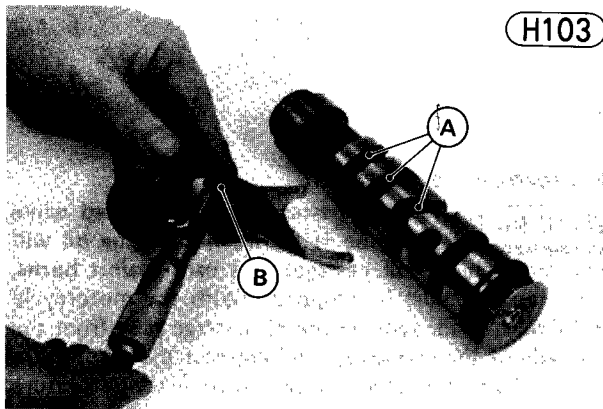

A. Shift Drum Grooves B. Shift Fork Guide Pin

Table H59 Shift Fork Guide Pin Diameter

	on Shift Rod	on Shift Drum
Service Limit	7.85 mm	7.93 mm

Table H60 Shift Drum Groove Width

Service Limit	8.25 mm
---------------	---------

Gear dog, gear dog hole, gear dog recess damage

Visually inspect the gear dogs, gear dog holes, and gear dog recesses. Replace any gears that have damaged, or unevenly or excessively worn dogs, dog holes, or dog recesses.

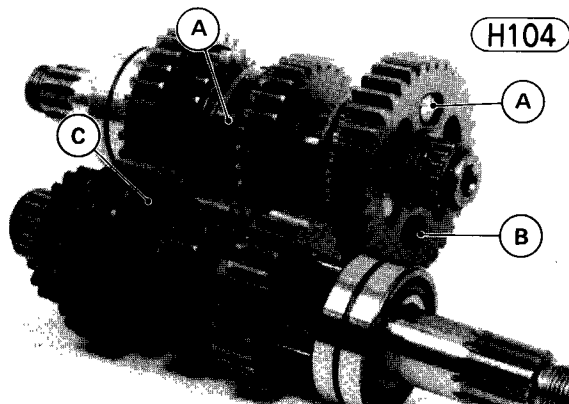

Gear/shaft clearance

Measure the diameter of each shaft and bush with a micrometer, and measure the inside diameter of each gear listed below. Find the difference between the two readings to figure clearance, and replace any gear where clearance exceeds the service limit.

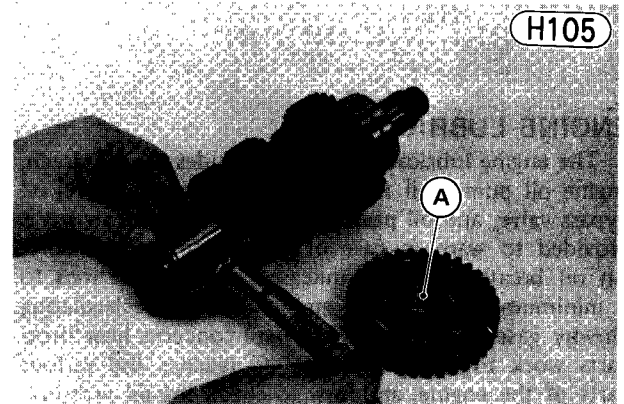

A. Bush

Table H61 Gear/Shaft, Gear/Bush Clearance

	O2, O3, D4, D5	O1
Service Limit	0.16 mm	0.15 mm

Shaft/needle bearing outer race wear

Measure the diameter of the drive and output shafts where it passes through the needle bearing. Replace the shaft if the diameter is less than the service limit. Measure the inside diameter of the needle bearing outer race with a cylinder gauge. Replace the outer race if the diameter exceeds the service limit. When replacing the shaft and/or outer race, replace the needle bearing also.

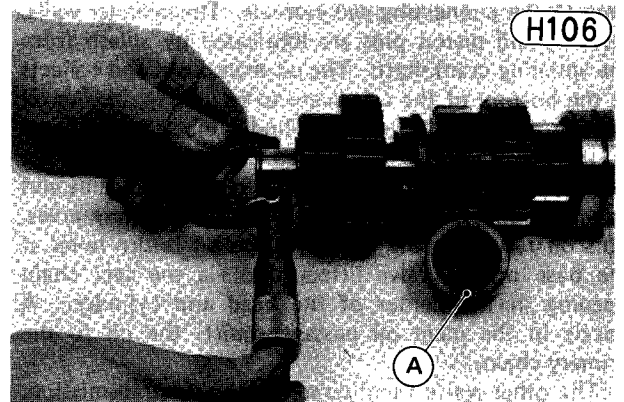

A. Needle Bearing Outer Race

Table H62 Shaft, Needle Bearing Outer Race Diameter

	Shaft	Outer Race
--	-------	------------

186 MAINTENANCE—ENGINE

Ball bearing, needle bearing wear, damage

Check the ball bearing and needle bearing (Pg. 190).

ENGINE LUBRICATION

The engine lubrication system includes the oil screen, engine oil pump, oil filter, oil pressure relief valve, oil bypass valve, and oil passages. An oil pressure switch is provided to warn in case of insufficient oil pressure. An oil breather keeps crankcase pressure variations to a minimum and reduces emissions by recirculating blowby gases. The discussion here concerns how these parts work together, how the oil reaches the various parts of the engine, and how to check the oil pressure. Details on the oil pressure switch, relief valve, engine oil pump, oil filter, and oil breather are given in the sections (Pgs. 186~190) following engine lubrication.

Since the engine lubrication system is a wet sump type, there is always supply of oil in the crankcase at the bottom of the engine. The oil is drawn through the wire screen into the oil pump as the pump rotors turn. The pump is driven by a gear on the secondary shaft. The screen removes any metal particles and other foreign matter which could damage the oil pump. From the pump the oil passes through the oil filter element for filtration. If the element is badly clogged, slowing the flow of oil through it, oil bypasses the element through a bypass valve in the oil filter mounting bolt. After passing through the filter, the oil branches into two lubrication routes.

One of these routes is through the oil pan passage to the crankcase main oil passage. Through the main oil passage, the oil flows to the crankshaft main bearings, then to the connecting rod journals. The cylinder walls, pistons, and piston pins are lubricated by splash from the spinning crankshaft. The oil then drops and collects at the bottom of the crankcase to be used again. An oil passage at each side of the cylinder block takes oil up to the top of the cylinder head. After lubricating the camshaft journals, the oil flows out over the cams and down around the valve lifters to lubricate these areas. This oil return to the sump via the oil return holes at the base of the valve lifters, and via the cam chain opening in the center of the head and cylinder. A nozzle in the main oil passage squirts the oil to the primary chain.

The other route for filtered oil is to the transmission. The oil flows through the orifice and passage between the right side of the crankcase and clutch cover to the secondary shaft. Then, the oil lubricates the secondary shaft coupling and starter motor clutch gear. The oil flows through an orifice to the output shaft needle bearing and drive shaft needle bearing. Finally the oil drops down into the crankcase after lubricating the

Oil Pressure Switch, Relief Valve

Both the oil pressure switch and the oil pressure relief valve are important for maintaining constant oil pressure. The oil pressure switch, mounted on the oil pan, checks on the oil pressure of the oil pump outlet and lights the oil pressure warning light if the pressure falls below a safe level. If the oil pressure is insufficient, the oil pump is worn or malfunctioning or there is an insufficient oil supply to the pump. On the other hand, if the oil pressure becomes excessive, such as when the engine is first started (especially in cold weather), the relief valve reduces the oil pressure. The relief valve opens whenever a pressure of 5.2 kg/cm² (74 psi) is exerted on the valve spring.

Oil pressure measurement

WARNING If the oil passage plug is removed while the engine is warm, hot engine oil will drain through the oil passage; take care against burns.

The engine must be stopped. With the motorcycle on its side stand, remove the oil passage plug from the right side of the crankcase, and connect the oil pressure gauge and adapter (special tools) in its place to measure oil pressure.

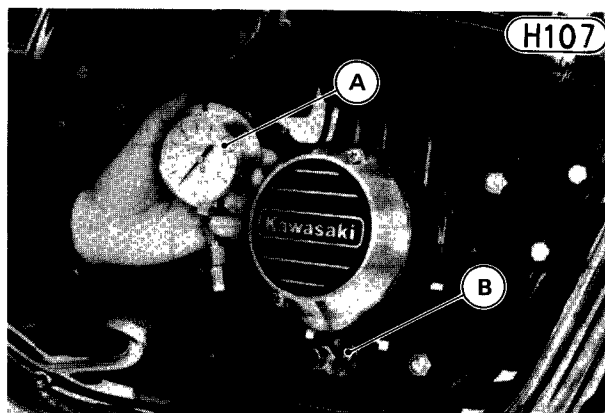

A. Oil Pressure Gauge (57001-164)
B. Adapter (57001-403)

Engine Lubrication System

H108

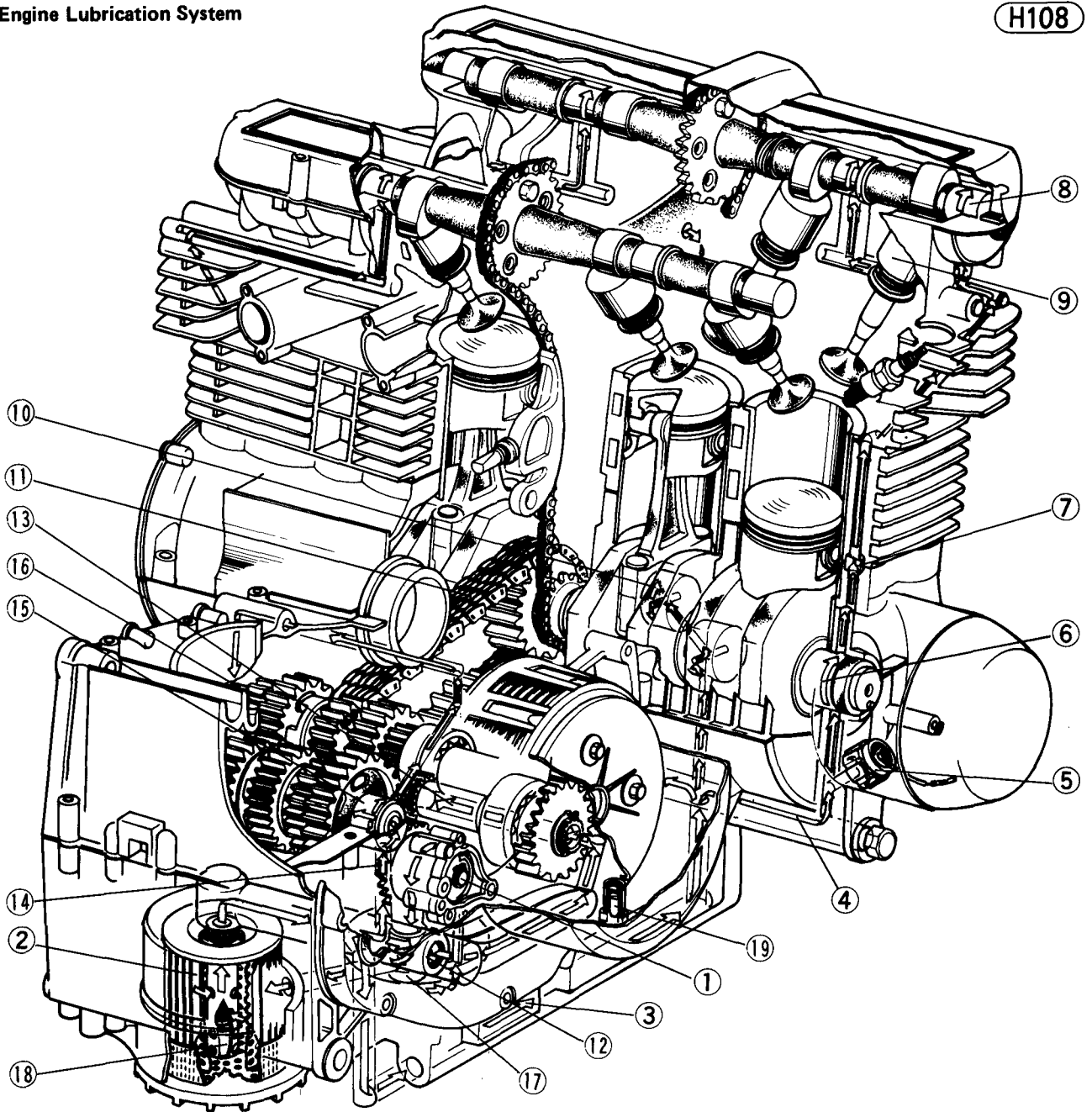

Engine Oil Flow Chart

H109

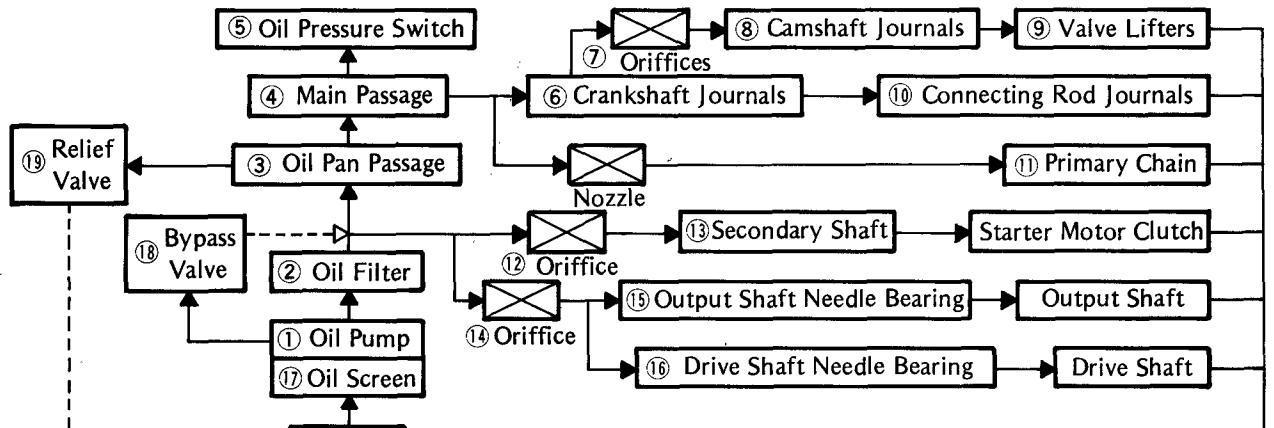

188 MAINTENANCE—ENGINE

Warm up the engine, and measure the oil pressure at the normal operating temperature.

- Run the engine at the specified speed (Table H64), and read the oil pressure gauge.

Table H64 Oil Pressure

Oil Pressure @4,000 rpm, 90°C (194°F)
2.0~2.5 kg/cm ² (28~36 psi)

If the oil pressure is significantly below the standard pressure, inspect the engine oil pump and relief valve. If the pump and relief valve are not at fault, inspect the rest of the lubrication system.

Oil pressure switch inspection

The switch should turn on the warning light whenever the ignition switch is on with the engine not running.

If the light does not go on, disconnect the switching lead. Connect the positive lead of a 20V DC range voltmeter to the switch lead and ground the voltmeter negative lead to the engine. Turn the ignition switch to the "ON" position, and read the voltmeter. If the voltmeter does not indicate battery voltage, the trouble is either defective wiring or a burned-out indicator bulb.

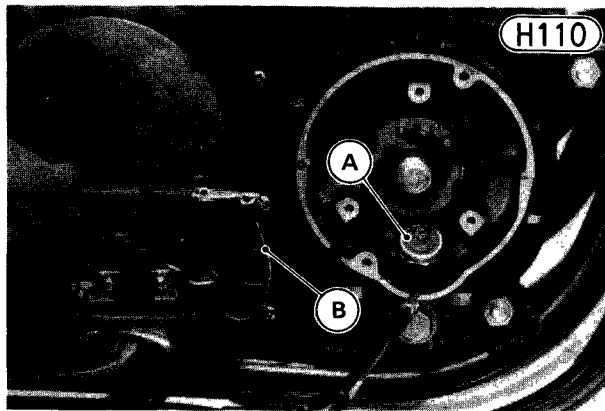

A. Oil Pressure Switch

B. Switch Lead

If the voltmeter does indicate battery voltage, then the oil pressure switch may be defective. Use an ohmmeter to check for continuity between the switch terminal and the switch body. With the switch lead disconnected, any reading other than zero ohms indicates that the switch is at fault.

The switch should turn off the warning light whenever the engine is running faster than the idle speed. If the light stays on, stop the engine and measure the oil pressure (Pg. 186). If the oil pressure is more than the specified value with the engine running at the specified speed, the oil pressure indicator switch is defective, and must be replaced.

NOTE: When installing a new switch, tighten it to 1.5 kg-m (11.0 ft-lbs) of torque.

Relief valve inspection

Check to see if the steel ball inside the valve slides

soft rod, and see if it comes back to its seat by valve spring pressure.

NOTE: Inspect the valve in its assembled state. Disassembly and assembly may change the valve performance.

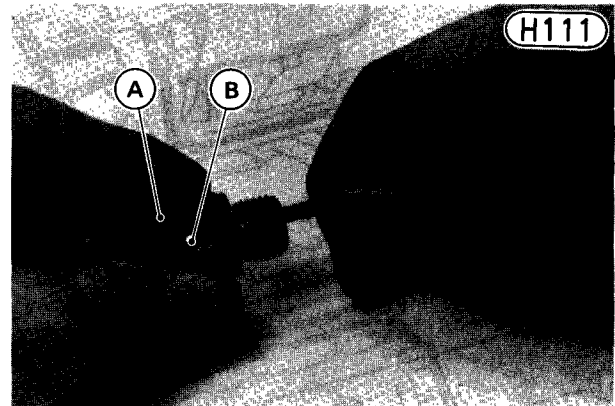

A. Relief Valve

B. Steel Ball

If any rough spots are found during the above inspection, wash the valve clean with a high flash-point solvent and blow out any foreign particles that may be in the valve with compressed air.

If cleaning does not solve the problem, replace the relief valve as an assembly. The relief valve is precision made with no allowance for replacement of individual parts.

Engine Oil Pump

The oil pump, installed in the right side of the lower crankcase half, is a simple trochoid type with an outer and an inner rotor. The gear on the pump is driven in direct proportion to engine rpm by a gear attached to the secondary shaft.

If the oil pump becomes worn, it may no longer be able to supply oil to lubricate the engine adequately.

Outer rotor/inner rotor clearance

Measure the clearance between the outer rotor and inner rotor with a thickness gauge. If the clearance exceeds the service limit, replace the rotors.

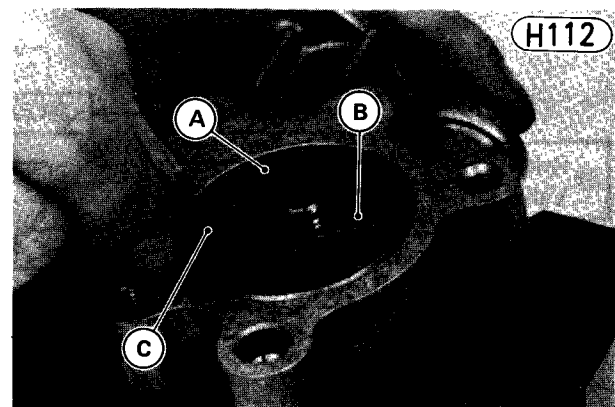

A. Outer Rotor

C. Thickness Gauge

Table H65 Outer Rotor/Inner Rotor Clearance

Service Limit	0.30 mm
---------------	---------

Outer rotor/pump body clearance

Measure the clearance between the outer rotor and the pump body with a thickness gauge. If the clearance exceeds the service limit, replace the oil pump assembly.

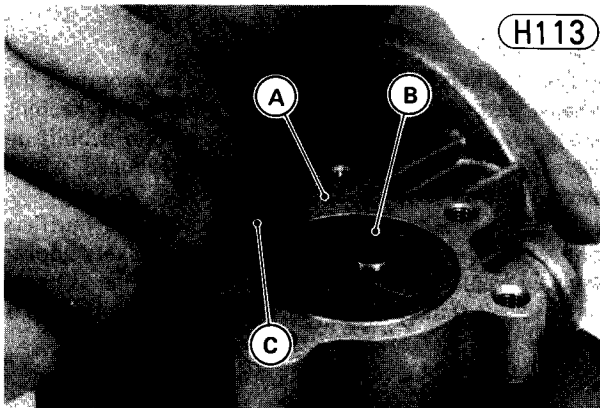

H113

A. Pump Body
B. Outer Rotor
C. Thickness Gauge

Table H66 Outer Rotor/Pump Body Clearance

Service Limit	0.30 mm
---------------	---------

Rotor side clearance

Lay a straightedge on the oil pump body, and measure the clearance between the straight edge and the rotors with a thickness gauge. If the clearance exceeds the service limit, replace the oil pump assembly.

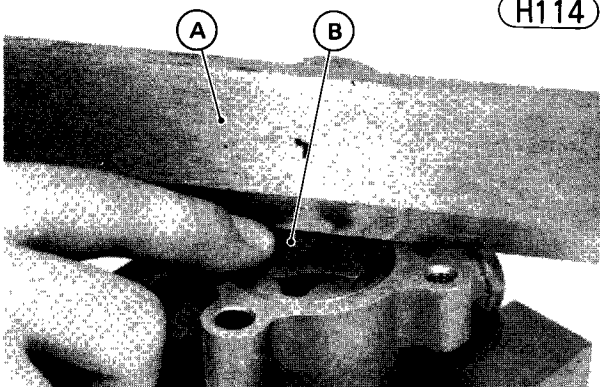

H114

A. Straightedge
B. Thickness Gauge

Table H67 Rotor Side Clearance

Service Limit	0.12 mm
---------------	---------

Oil Filter

The oil filter, located in the lower part of the crankcase, removes impurities from the oil.

As the filter element becomes dirty and clogged, its filtering efficiency is impaired. If it becomes so clogged that it seriously impedes oil flow, a pressure-activated bypass valve in the oil filter mounting bolt opens so that sufficient oil will still reach the parts of the engine needing lubrication. When the filter becomes clogged such that the oil pressure difference between the inlet and outlet for the filter reaches a certain pressure, the oil on the inlet side pushing on the valve spring opens the valve, allowing oil to flow to the main oil passage, bypassing the filter.

Never neglect the oil filter, or else metal particles or other foreign matter in the oil could reach the crankshaft and transmission, accelerating wear and shortening engine life.

Oil Filter

H115

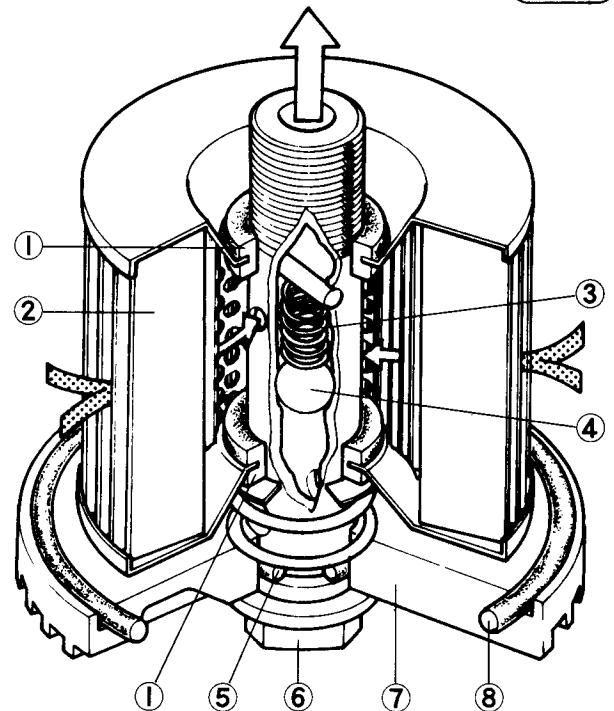

- | | |
|----------------------------|------------------|
| 1. Grommet | 5. O Ring |
| 2. Filter Element | 6. Mounting Bolt |
| 3. Spring | 7. Filter Cover |
| 4. Bypass Valve Steel Ball | 8. O Ring |

Oil filter replacement

Replace the filter element in accordance with the Periodic Maintenance Chart (Pg. 10) since it becomes clogged with metal fillings from the engine and transmission especially during break-in. After break-in, replace the element at every other oil change. When the filter is removed for element replacement, wash the rest of the filter parts in a high flash-point solvent and check the condition of the O rings. If the O rings are worn or

190 MAINTENANCE—ENGINE

Oil Breather

The oil breather is located on the top of the crankcase. The front right side of the breather opens to the crankcase, while the upper part connects through the breather hose to the air cleaner. Its function is to minimize crankcase pressure variations caused by crankshaft and piston movement and to recycle blowby gas.

Gas blowby is combustion chamber gas which have escaped past the rings into the crankcase. A small amount is unavoidable, but gas blowby increases as cylinder wall and piston ring wear progresses. If not efficiently removed, blowby gas will seriously contaminate the engine oil.

Recycling blowby gas means more efficient combustion but the oil mist resulting from transmission gear movement must first be removed. The mixture of blowby gas and oil mist passes the breather, which separates most of the oil from the gas. The oil which is separated from the gas returns to the bottom of the crankcase. The gas is drawn through the breather hose into the air cleaner housing, and from there, through the carburetors into the engine.

If the breather hose or the parts inside the breather become clogged, pressure may build up in the crankcase and cause oil leaks.

NOTE: If the engine is overfilled with engine oil, mist from the excess oil will go through the oil breather to clog the air cleaner and cause carburetion trouble. This is not the fault of the oil breather.

BALL BEARING, NEEDLE BEARING

Ball bearing wear, damage

Since the ball bearings are made to extremely close tolerances, the wear must be judged by feel rather than by measurement.

Clean each bearing in a high flash-point solvent, dry it (do not spin it while it is dry), and oil it. Spin it by hand to check its condition. If it is noisy, does not spin smoothly, or has any rough spots, replace it.

Needle bearing wear, damage

The rollers in the needle bearings wear so little that the wear is difficult to measure. Instead, inspect the bearings for abrasion, color change, or other damage. If there is any doubt as to the condition of either bearing, replace it.

Oil seal damage

Inspect the oil seals, and replace any if the lips are misshapen, discolored (indicating the rubber has deteriorated), hardened, or otherwise damaged. Since an oil seal is nearly always damaged on removal, any removed oil seals must be replaced. When pressing in an oil seal which is marked, press it in with the mark facing outward. Press the seal in so that the face of the seal is level with the surface of the hole.

MUFFLER

The mufflers reduce exhaust noise and conduct the exhaust gases back away from the rider while keeping power loss to a minimum. If much carbon is built up inside the muffler, exhaust efficiency is reduced, which lowers the engine power output.

If there is any exhaust leakage where the mufflers connect to the cylinder head, or if the gaskets appear damaged, replace the gaskets. If either muffler is badly damaged, dented, cracked or rusted, replace it with a new one.

OIL SEAL

Any damaged, hardened, or otherwise defective oil

Maintenance—Chassis

Table of Contents

WHEEL	192
Tire	192
Rim	195
Air Valve	196
Axle	196
Grease Seal	196
Wheel Bearing	197
Rear Wheel Coupling	197
Speedometer Gear Housing	197
DRIVE CHAIN	197
SPROCKET	199
BRAKE	200
Automatic Wear Adjustment	200
Braking Stroke	200
Braking Release Stroke	200
Master Cylinder	201
Caliper	203
Brake Disc	205
Brake Fluid	205
Brake Hose	208
STEERING STEM	208
FRONT FORK	209
Compression Stroke	210
Extension Stroke	210
Spring	211
Inner Tube, Guide Bush	211
Oil Seal, Dust Seal	212
Fork Oil	212
REAR SHOCK ABSORBER	213
SWING ARM	214

192 MAINTENANCE—CHASSIS

WHEEL

Tubeless tires are installed on the wheels of this motorcycle. The main advantage of tubeless tires is an added measure of driving safety. In the event of a puncture, tubeless tires do not blow out but instead tend to lose air gradually. Another advantage is cooler running characteristics.

The tire and rim form a leakproof unit by making airtight contacts at the tire chafers and the rim flanges instead of using an inner tube.

WARNING The tires, rims, and air valves on this motorcycle is designed only for tubeless type wheels. The recommended standard tires, rims, and air valves must be used for replacement. For correct performance, do not install a tube in a tubeless tire.

Tire

Structure of the tubeless tire is characterized by an inner liner and chafers.

The inner liner is a layer of thicker rubber which covers the inside wall of the tire. The inner liner is made from special quality of rubber which is hard to admit the air. Generally chafers reinforce tire beads which are likely damaged by friction with the rim. The chafers of tubeless tires have a characteristic of airtightness as well.

Since airtightness of tubeless tires is accomplished by closely seating the chafers in good condition on the rim, be careful not to damage the chafers when handling tubeless tires.

Tubeless Tire

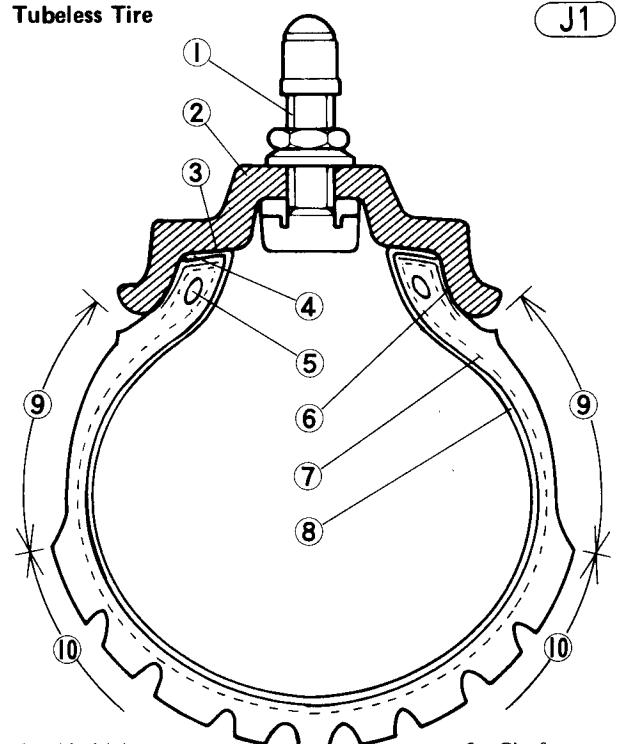

1. Air Valve
2. Rim
3. Rim Sealing Area
4. Bead Sealing Area
5. Bead Wires
6. Chafers
7. Plies
8. Inner Liner
9. Side Wall
10. Tread

The indication of "TUBELESS" on the tire sidewall

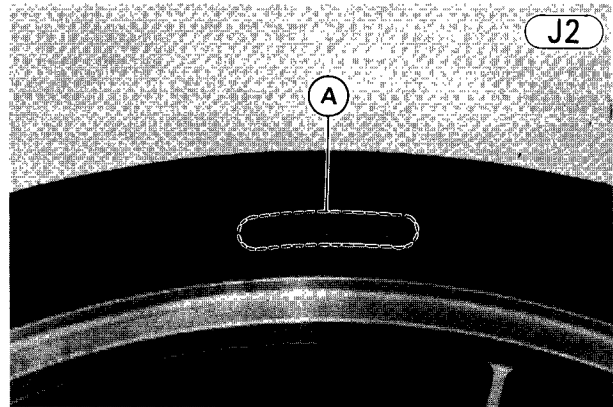

A. "TUBELESS"

The tires are designed to provide good traction and power transmission during acceleration and braking, even on bad surfaces. To do this, they must be inflated to the correct pressure and not overloaded. The maximum recommended load, in addition to vehicle weight, is 165 kg.

If the tires are inflated to too high a pressure, the ride is rough, the center portion of the tread wears quickly, and the tires are easily damaged.

If inflation pressure is too low, the shoulder portions wear quickly, the cord suffers damage, fuel consumption is high and handling is poor. In addition, heat builds up at high speeds, and tire life is greatly shortened.

Table J1 Standard Tire

		Size	Make, Type
KZ750-E	Front	3.25H-19 4PR	DUNLOP, GOLD SEAL F8 Tubeless
	Rear	4.00H-18 4PR	DUNLOP, GOLD SEAL K127 Tubeless
KZ750-H	Front	3.25H-19 4PR	DUNLOP, GOLD SEAL F8 Tubeless or BRIDGESTONE, Mag Mopus L303A Tubeless
	Rear	130/90-16 67H 4PR	DUNLOP, GOLD SEAL K127 Tubeless or BRIDGESTONE, Mag Mopus S708A Tubeless

WARNING To ensure safe handling and stability, use only the recommended standard tires for replacement, inflated to the standard pressure (Tables J1 and J2). A certain variation from the standard pressure may be desired depending on road surface conditions (rain, snow, rough surface, etc.).

Tire wear, damage

Tires must not be used if they are nearly bald, or if they are cut or otherwise damaged. As the tire

the puncture and failure. 90% of tire failures occur during the last 10% of tire life.

Visually inspect the tire for cracks and cuts. Replace the tire in case of bad damage. Remove any imbedded stones or other foreign particles from the tread. Swelling or high spots indicate internal damage, requiring tire replacement unless the damage to the fabric is very minor.

Measure the depth of the tread with a depth gauge, and replace the tire if the tread depth is less than the service limit.

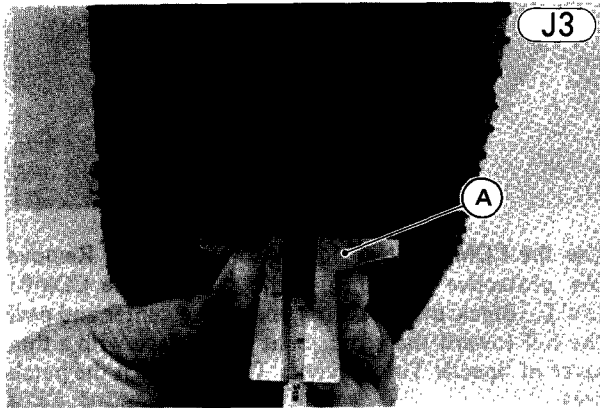

A. Depth Gauge

Tire repair

Currently two types of repair for tubeless tires have come into wide use. One type is called temporary (external) repairs which can be carried out without removing the tire from the rim, and another type is called permanent (internal) repairs which require tire removal. It is generally understood that higher running durability is obtained by permanent (internal) repairs than by temporary (external) ones. Also, permanent (internal) repairs also have the advantage of permitting a thorough examination for secondary damage not visible from external inspection of the tire. For these reasons, Kawasaki does not recommend temporary (external) repair. Only appropriate permanent (internal) repairs are recommended.

The tubeless tire repair methods described here describe the methods for COMBI UNITS made by TIP

TOP (trade names). Repair methods may vary slightly from make to make. Follow the repair methods indicated by the manufacturer of the repair tools and materials so that safe results can be obtained.

WARNING Tires that have been punctured and replaced do not have the same capabilities as unchanged tires. When being repaired with COMBI UNITS made by TIP TOP, do not exceed 80 kph within 24 hours after repair, and 180 kph (113 mph) at any time after that.

- Locate and mark the puncture and remove the injuring object.
- Remove the tire from rim (Pg. 116).
- Inspect the tire carefully. If any damage mentioned below is found, replace the tire with a new one:
 1. Puncture or tear larger than 3 mm diameter.
 2. Two punctures within 40 cm distance.
 3. Three punctures or more in one tire.
 4. Puncture or damage on sidewall.
- Inspect the rim. If there is any damage such as is mentioned on Pg. 195, replace the rim with a new one
- Repair the tire puncture. COMBI UNITS made by TIP TOP are used here to describe the internal repair methods of tubeless tires.
- Spread the tire slightly at the injury with the bead breaker (special tool). Choose a drill bit of slightly greater diameter than the injury.

NOTE: The diameter of a drill must be less than 3 mm at maximum.

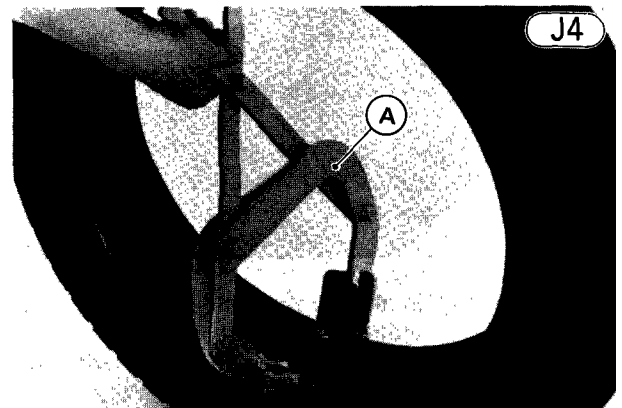

A. Bead Breaker (57001-1072)

Table J2 Tire Air Pressure, Tread Depth

		Air Pressure (when cold)						Minimum Tread Depth	
		KZ750-E		KZ750-H (US and Canadian)		KZ750-H (European)		KZ750-E	KZ750-H
Front		2.00 kg/cm ² (28 psi, 200 kPa)		1.75 kg/cm ² (25 psi, 175 kPa)		Up to 180 kph (110 mph)	Over 180 kph (110 mph)	1 mm	
						1.75 kg/cm ² (25 psi, 175 kPa)	2.00 kg/cm ² (28 psi, 200 kPa)		
Rear	Up to 97.5 kg (215 lbs) load	2.25 kg/cm ² (32 psi, 225 kPa)	Up to 97.5 kg (215 lbs) load	1.5 kg/cm ² (22 psi, 150 kPa)	Up to 95 kg (210 lbs) load	1.75 kg/cm ² (25 psi, 175 kPa)	2.00 kg/cm ² (28 psi, 200 kPa)	Under 130 kph (80 mph)	2 mm
	97.5 ~ 165 kg (215 ~ 364 lbs)	2.50 kg/cm ² (36 psi, 250 kPa)	97.5 ~ 165 kg (215 ~ 364 lbs)	1.75 kg/cm ² (25 psi, 175 kPa)	95 ~ 136 kg (210 ~ 300 lbs) load	2.00 kg/cm ² (28 psi, 200 kPa)	2.25 kg/cm ² (32 psi, 225 kPa)	Over 130 kph (80 mph)	2 mm
					136 ~ 180 kg (300 ~ 397 lbs) load	2.25 kg/cm ²	2.50 kg/cm ²		

194 MAINTENANCE—CHASSIS

- Before buffing the tires, thoroughly clean the area around the puncture with a suitable solvent and scrape out all mold lubricants (i.e. silicon, graphite, etc.). Let dry before buffing.
- Center the COMBI UNIT on the puncture inside of the tire and draw an outline (do not use crayon).

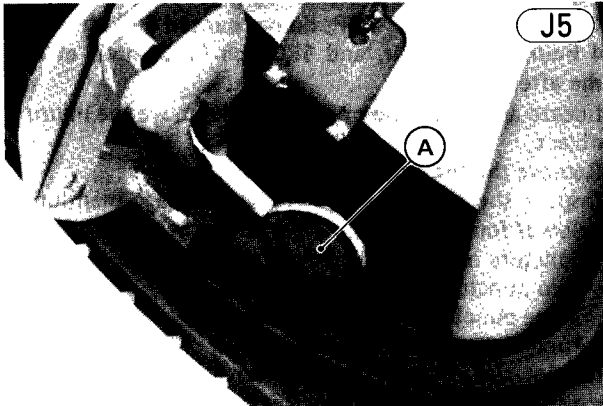

A. COMBI UNIT

- Buff the area slightly larger than the COMBI UNIT, remove the buffing dust.

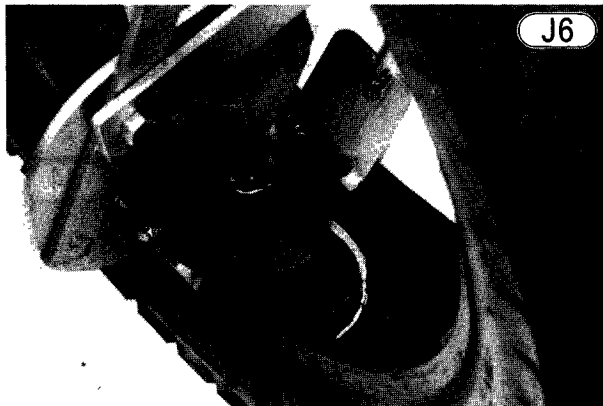

- Center the drill in the break inside of the tire and screw into the puncture.

NOTE: Be careful not to expand the injury with the drill.



- Clean the buffed area thoroughly.
- Coat the puncture channel with a heavy layer of Rema

- spread a thin, even coat of the same Cement to the buffed surface. Keep the repair area up to permit faster evaporation of solvent. Allow approximately 10 minutes for drying.



- Use the COMBI UNIT for motorcycle tires. Remove the protective sleeve from the stem of the COMBI UNIT. Break the metal foil across the center and peel the foil toward the edge. Coat the surface with a thin layer of Special Tire Cement. Do not touch the patch area.

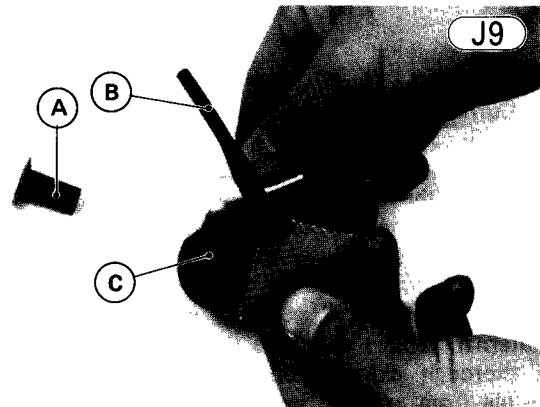

- A. Protective Sleeve
- B. Metal Foil
- C. COMBI UNIT

- Run the stem of the COMBI UNIT patch through the inserting wire.

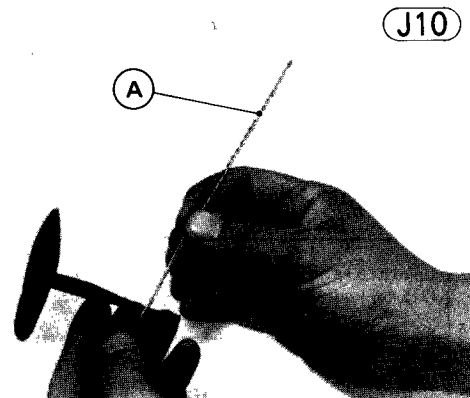

- Apply Special Tire Cement to the upper end of the stem (30 mm above the patch) so that the stem of COMBI UNIT patch slips smoothly.
- Pull the end of the stem through the puncture without turning until the base presses against inside of the tire.

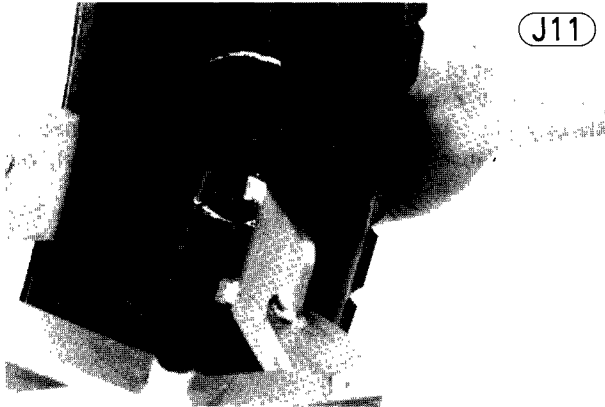

- Roll the stitcher over the patch as hard as possible, keeping strokes close together and working from the center outwards.
- Cut off the protruding rubber tail flush with the tire surface.

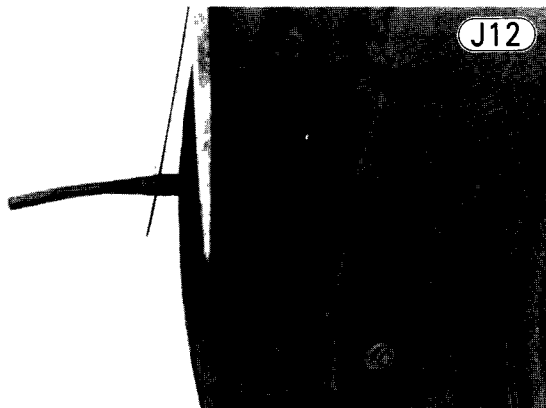

- Install the tire on the rim (Pg. 117).
- Balance the wheel (Pg. 27).

Rim

The rims for tubeless tires are specially designed in shape, size and finish to be airtight and to keep the tire from coming off the rim.

The indication "TUBELESS" on the rim shows that

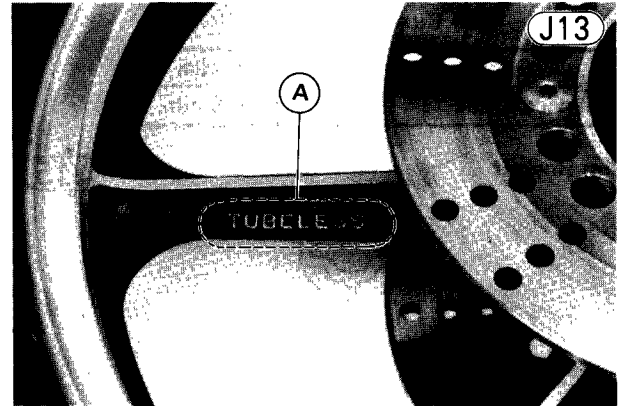

A. "TUBELESS"

Table J3 Rim Size*

Front	Rear
19 x MT1.85	KZ750E: 18 x MT2.15 KZ750H: 16 x MT3.00

* The rim size shown in the table is the bead seat diameter and inner width of the rim flanges, both in inches.

Rim Sizes

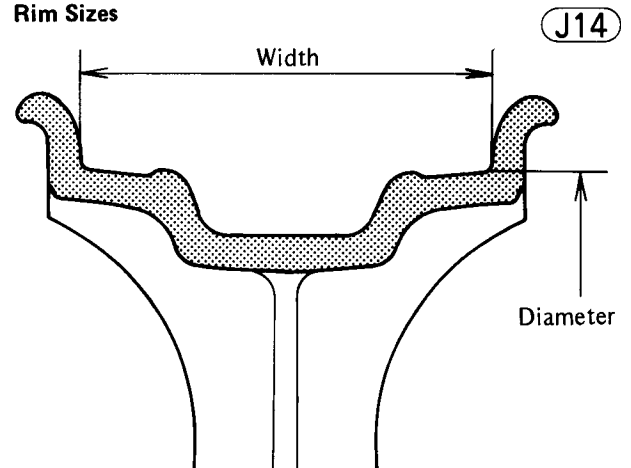

Rim runout measurement

If there is any doubt as to the condition of the wheel, or if the wheel has received a heavy impact, check the rim runout as follows:

Remove the tire and suspend the wheel by the axle. Set a dial gauge against the side of the rim, and rotate the wheel to measure the axial runout. The difference between the highest and lowest dial readings is the amount of runout.

Set the dial gauge against the outer circumference of the rim, and rotate the wheel to measure radial runout. The difference between the highest and lowest dial readings is the amount of runout.

If rim runout exceeds the service limit, check the wheel bearings first. Replace them if they are damaged. If the problem is not due to the bearings, the wheel must

196 MAINTENANCE—CHASSIS

Table J4 Rim Runout

	Axial	Radial
Service Limit	0.5 mm	0.8 mm

Rim Runout

J15

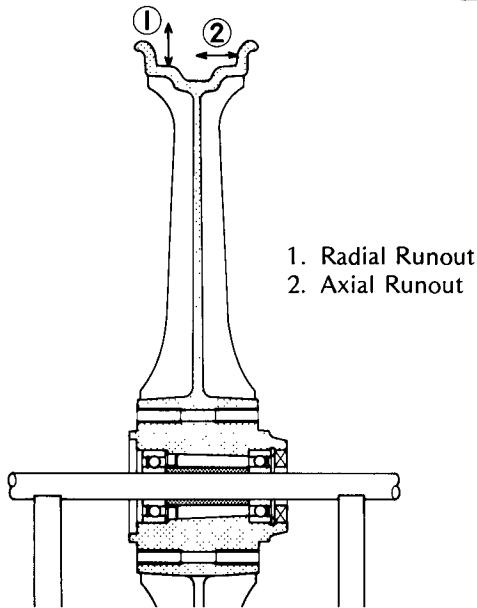

Rim damage

Carefully inspect the wheel for small cracks, dents, bents, or warp. If there is any damage to the wheel, it must be replaced.

WARNING Never attempt to repair a damaged wheel. If there is any damage besides wheel bearings, the wheel must be replaced to insure safe operational condition.

If the rim has a scratch deeper than 0.5 mm and/or across the rim sealing surface, replace the wheel.

Air Valve

For tubeless tires, the air valve is installed directly on the rim. The airtightness between the rim and the valve stem is ensured with a rubber grommet.

Air Valve

J16

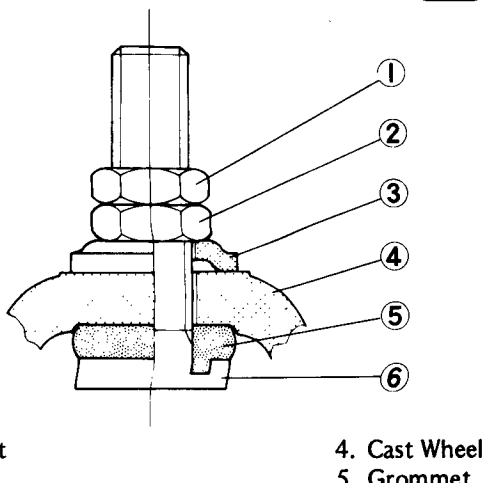

Axle

A bent axle causes vibration, poor handling, and instability.

Axle runout measurement

To measure axle runout, remove the axle, place it in V blocks that are 100 mm apart, and set a dial gauge to the axle at a point halfway between the blocks. Turn the axle to measure the runout. The amount of runout is the amount of dial variation.

If runout exceeds the service limit, straighten the axle or replace it. If the axle cannot be straightened to within tolerance, or if runout exceeds repair limit, replace the axle.

Axle Runout

J17

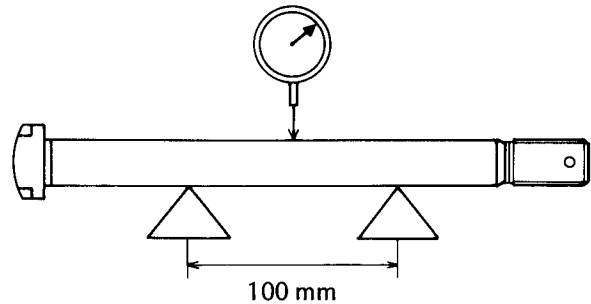

Table J5 Axle Runout/100 mm

Service Limit	Repair Limit
0.2 mm	0.7 mm

Grease Seal

A grease seal is fitted in the speedometer gear housing, in the right side of the front and rear hubs, and in the rear wheel coupling. Each grease seal is a rubber ring equipped with a steel band on its outer circumference. The grease seal inner lip is held against the axle collar by a wire spring band. Since the grease seal not only seals in the wheel bearing grease but also keeps dirt and moisture from entering the hub, the use of a damaged grease seal will cause the wheel bearing to wear quickly.

Grease Seal

J18

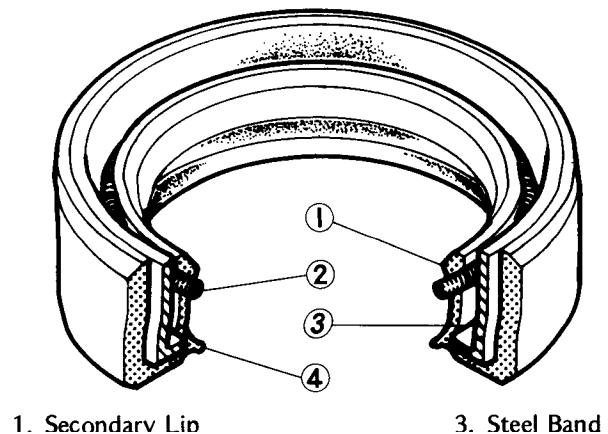

Inspection

If the grease seals are examined without removing the seals themselves, look for discoloration (indicating the rubber has deteriorated), hardening, damage to the internal ribbing, or other damage. If the seal or internal ribbing has hardened, the clearance between the seal and the axle sleeve will not be taken up, which will allow dirt and moisture to enter and reach the bearing. If in doubt as to its condition and whenever the seal is removed for greasing the bearing, the seal should be replaced. The seals are generally damaged upon removal.

Wheel Bearing

A wheel bearing is fitted in both sides of each hub. Since worn wheel bearings will cause play in the wheel, vibration, and instability, they should be cleaned, inspected, and grease periodically.

Inspection and lubrication

Since the wheel bearings are made to extremely close tolerances, the clearance cannot normally be measured. Wash the bearing with a high flash-point solvent, dry it (do not spin it while it is dry), and oil it. Spin it by hand to check its condition. If it is noisy, does not spin smoothly, or has any rough spots, it must be replaced. If the same bearing is to be used again, re-wash it with a high flash-point solvent, dry it, and pack it with good quality bearing grease before installation. Turn the bearing by hand a few times to make sure the grease is distributed uniformly inside the bearing, and wipe the old grease out of the hub before bearing installation. Clean and grease the wheel bearings in accordance with the Periodic Maintenance Chart (Pg. 10).

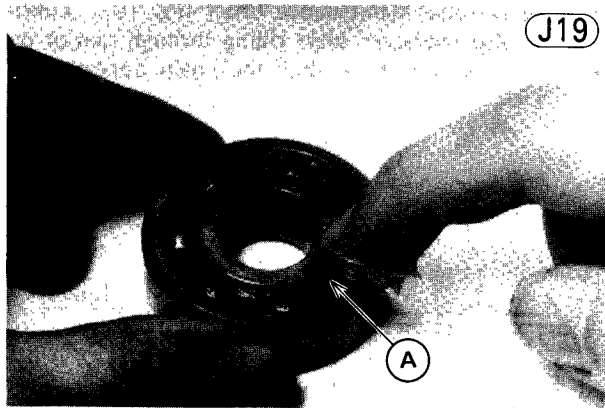

A. Grease.

Rear Wheel Coupling

The rear wheel coupling connects the rear sprocket to the wheel. A rubber shock damper in the coupling absorbs some of the shock resulting from sudden changes in torque due to acceleration or braking.

Damper inspection

Remove the rear wheel coupling, and inspect the

Replace the damper if it appears damaged or deteriorated.

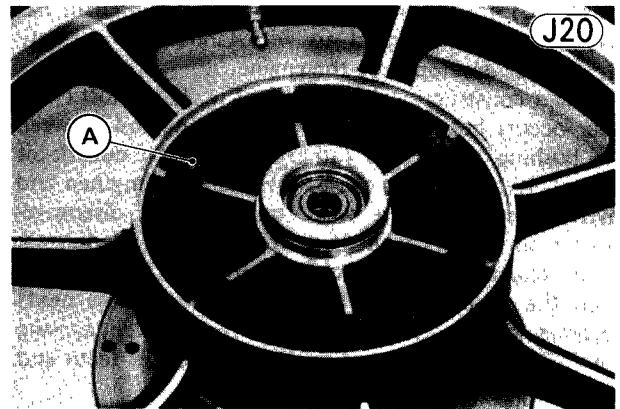

A. Rubber Damper

Speedometer Gear Housing

The speedometer gear housing is mounted on the left side of the front hub. The speedometer gear and pinion are in the housing, transmit the revolution of the front wheel to the speedometer through the speedometer cable.

The speedometer gear housing should be greased periodically.

Lubrication

Clean and grease the speedometer gear housing in accordance with the Periodic Maintenance Chart (Pg. 10).

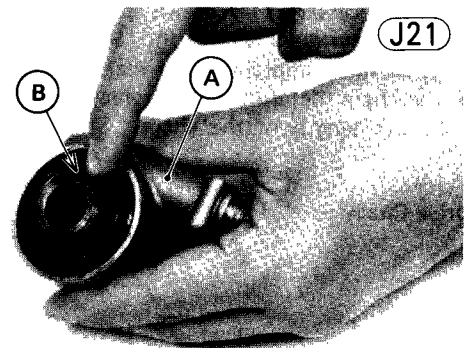

A. Speedometer Gear Housing B. Grease.

DRIVE CHAIN

The drive chain is an "endless" type in which the weakest link, the master link has been eliminated by constructing the chain in a closed loop. To preserve

198 MAINTENANCE—CHASSIS

install it; follow the replacement procedure given in the "Disassembly" section of this manual. When chain replacement is necessary, use only the standard chain (Table J6) for replacement, since only this chain has been especially designed to withstand the extremely high torque developed by the engine.

Chain construction is shown in Fig. J23. Most chain wear occurs between the pin and bushing and between the bushing and roller, rather than on the outside of the roller. This wear causes the chain to lengthen and invites noise, excessive wear, breakage and disengagement from the sprocket if the chain is left unadjusted. If the chain is allowed to wear too much, the chain pitch (i.e., the distance from one roller to the next) becomes much greater than the sprocket pitch, causing the chain to slide up and down the sprocket teeth and wear even faster.

The wear between the pin and bushing is greatly reduced by providing O rings to seal in the lubricant between the pin and bushing. The wear between bushing and roller can be minimized by frequent and sufficient lubrication.

Table J6 Drive Chain

Make	Type	Link
Enuma	EK630S-T ₃ O	84 links

Wear

When the chain has worn so much that it is more than 2% longer than when new, it is no longer safe for use and should be replaced. Whenever the chain is replaced, inspect both the engine and rear sprockets and replace them if necessary. Overworn sprockets will cause a new chain to wear quickly. See the "Sprocket" section.

Since it is impractical to measure the entire length of the chain, determine the degree of wear by measuring a 20-link length of the chain. Stretch the chain taut

either by using the chain adjuster, or by hanging a 10 kg weight on the chain. Measure the length of 20 links on a straight part of the chain from pin center of the 1st pin to pin center of the 21st pin. Since the drive chain may wear unevenly, take measurements at several places. If any measurement exceeds the service limit, replace the chain.

NOTE: The drive system was designed for use with the standard chain. For maximum strength and safety, the standard chain must be used for replacement.

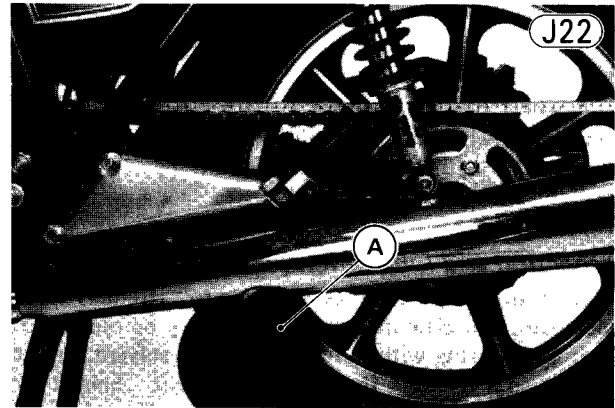

A. 10 kg Weight

Table J7 Drive Chain 20-link Length

Service Limit	389 mm
---------------	--------

Lubrication

In order for the chain to function safely and wear slowly, it should be properly lubricated in accordance with the Periodic Maintenance Chart (Pg. 10). Lubrication is also necessary after riding through rain or on wet roads, or any time that the chain appears dry.

Drive Chain

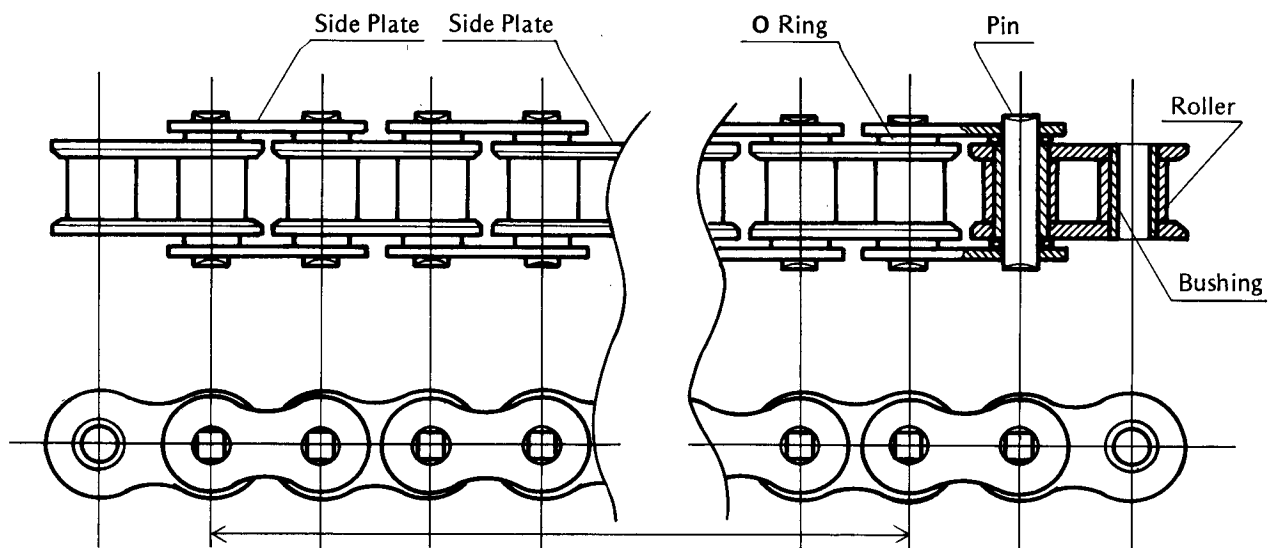

J23

Anytime that the motorcycle has been washed, the chain should be adequately lubricated on the spot in order to avoid rust.

The chain should be lubricated with a lubricant which will both prevent the exterior from rusting and also absorb shock and reduce friction in the interior of the chain. An effective, good quality lubricant specially formulated for chains is best for regular chain lubrication. If a special lubricant is not available, a heavy oil such as SAE 90 is preferred to a lighter oil because it will stay on the chain longer and provide better lubrication. Apply the oil to the sides of the rollers so that it will penetrate to the rollers and bushings. Wipe off any excess oil.

J24

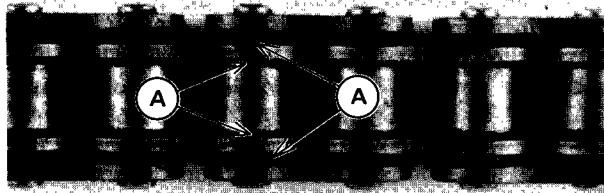

A. Spring

B. Free Length

If the chain is especially dirty, it should be washed in Diesel oil or kerosene, and afterward soaked in a heavy oil. Shake the chain while it is in the oil so that oil will penetrate to the inside of each roller.

SPROCKET

There are two sprockets for the drive chain. A forward sprocket, or engine sprocket, is mounted on the end of the output shaft and is used to drive the chain. A rear sprocket is connected to the rear wheel hub through the rear wheel coupling and is driven by the chain to turn the rear wheel.

Sprockets that have become excessively worn cause chain noise and greatly accelerate chain and sprocket wear. The sprockets should be checked for wear any time that the chain is replaced. A warped rear sprocket destroys chain alignment such that the chain may break or jump from the sprockets when traveling at high speed. The sprockets should be checked for wear and the rear

Sprocket wear

Visually inspect the sprocket teeth. If they are worn as illustrated, replace the sprocket.

Sprocket Teeth

J25

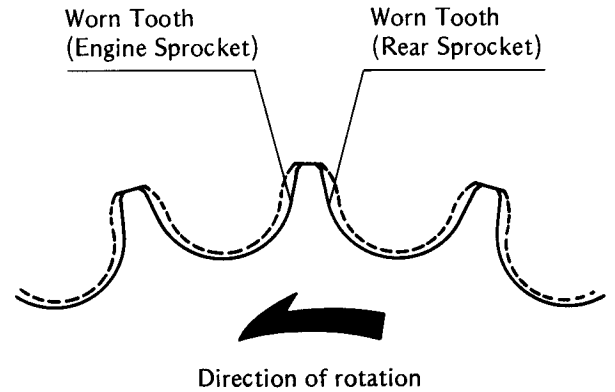

Measure the diameter of the sprocket at the base of the teeth. If the sprocket is worn down to less than the service limit, replace the sprocket.

J26

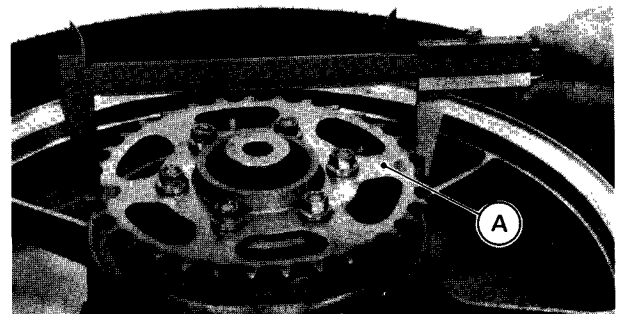

A. Rear Sprocket

Table J8 Sprocket Diameter

	Engine	Rear	
		KZ750-E	KZ750-H
Service Limit	66.2 mm	182.1 mm	188.0 mm

NOTE: If a sprocket requires replacement, the chain is probably worn also. Upon replacing a sprocket, inspect the chain.

Rear sprocket warp

Elevate the rear wheel so that it will turn freely, and set a dial gauge against the rear sprocket near the

200 MAINTENANCE—CHASSIS

The difference between the highest and lowest dial gauge readings is the amount of runout (warp).

If the runout exceeds the service limit, replace the rear sprocket.

Table J9 Rear Sprocket Warp

Service Limit	0.5 mm
---------------	--------

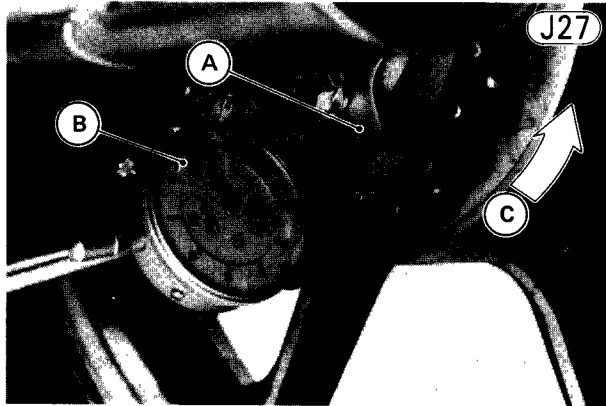

A. Rear Sprocket

B. Dial Gauge

C. Turn.

BRAKE

A hydraulic disc brake is used on each wheel for superior braking performance and high reliability. The major components of each disc brake are the brake lever (front) or the brake pedal (rear), master cylinder, brake line, caliper assembly, and disc. The brake lever is pulled or the brake pedal is pushed to move a piston in the master cylinder and pressurize the brake fluid. Fluid pressure is transmitted through the brake line to operate the caliper. The caliper grips the disc attached to the wheel, slowing wheel rotation. Front brake lever pushes the front brake light switch, and the rear brake pedal pulls the rear brake light switch. Each switch turns on the brake light.

Unlike a drum-type brake, the components of the disc brake which perform the actual braking action, i.e., the disc and pads, are open to direct contact with the air flow past the motorcycle. This provides for excellent dissipation of the heat from brake friction, and minimizes the possibility of brake fade common to drum brakes.

The automatic wear adjustment mechanism of the

and caliper operation is the same as for the front caliper except that the rear caliper is held stationary and has two pistons. So a separate explanation of the braking and release strokes of the rear caliper will be omitted.

Automatic Wear Adjustment

When fluid pressure develops in the cylinder, the piston is pushed exerting pressure against the brake pad, which in turn presses against the brake disc. The pressurized fluid is prevented from leaking by a fluid seal fitted into the cylinder wall. The seal is pressed against the piston and, instead of sliding when the piston moves, the seal is only distorted, allowing no fluid leakage at all (See Fig. J29). When the brake lever or pedal is released and fluid pressure lowers, the elasticity of the seal returns the piston to its original position. After the brakes are used for a while and the pads wear slightly, the rubber seal will no longer be able to distort the additional amount that the piston travels. Instead, when piston travel forces the seal past its limit, the seal slips on the piston. The seal then returns the piston to a new rest position that is closer to the disc.

A small amount of fluid from the reservoir supplements the fluid in the brake line to compensate for the difference in piston position. Consequently, the length of the brake lever or pedal stroke remains unchanged, and the brake never needs adjustment.

The seal and the cup at the head of the master cylinder piston are made of special heat resistant rubber for best performance and to prevent deterioration. For this reason, only standard parts should be used.

Braking Stroke

When the brake lever is pulled, the piston ① in the master cylinder is pushed and moves forward against the force of the return spring ⑧. At this time, the primary cup ⑨ at the head of the piston closes the small relief port ④, which connects the pressure chamber and the reservoir ⑥. Until this port is fully closed, the brake fluid does not start being pressurized, in spite of the forward movement of the piston.

The pressure stroke starts as soon as the relief port is closed. The piston compresses the brake fluid, which is being used as the pressure medium, forcing it out into the brake line. The pressure is transmitted through the line to the cylinder portion of the caliper assembly, where it forces the piston ① towards the disc. The piston presses pad A against the disc, but since the disc is immovable, further pressure cannot move the pad any farther. Instead, the entire caliper assembly moves in the opposite direction such that pad B is also forced against the disc. In this manner, the disc is gripped between the two pads, and the resulting friction slows wheel rotation.

Braking Release Stroke

When the brake lever is released, the piston in the master cylinder is quickly returned toward its rest position by the spring ⑧, and brake fluid pressure drops

J28

Braking Stroke

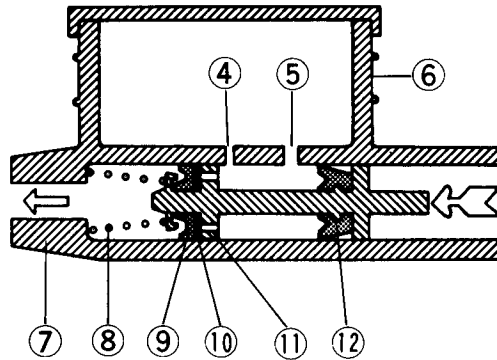
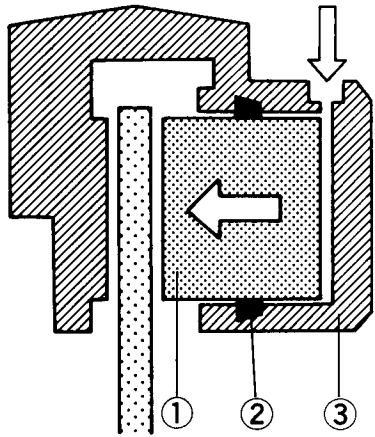

1. Piston
2. Fluid Seal
3. Caliper
4. Relief Port
5. Supply Port
6. Reservoir
7. Master Cylinder
8. Spring
9. Primary Cup
10. Non-return Valve
11. Piston
12. Secondary Cup

Braking Release Stroke

J29

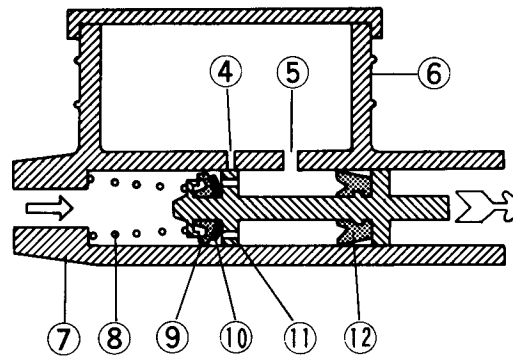
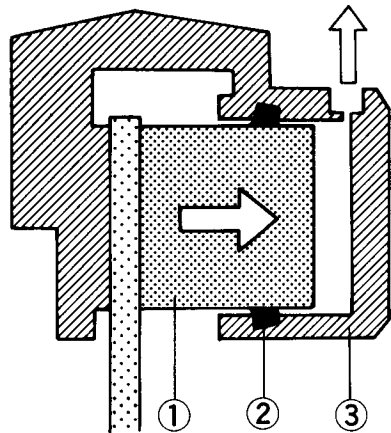

1. Piston
2. Fluid Seal
3. Caliper
4. Relief Port
5. Supply Port
6. Reservoir
7. Master Cylinder
8. Spring
9. Primary Cup
10. Non-return Valve
11. Piston
12. Secondary Cup

the fluid seal ② in the cylinder then returns the piston. This leaves no pressure against either pad A or B so that slight friction against the disc pushes them both slightly away from the disc.

As the master cylinder piston moves back further, the brake fluid in the line rushes to fill the low pressure area in front of the primary cup at the piston head. At this time, fluid from the reservoir flows through the large supply port ⑤ into the space between the primary and secondary cups, through the non-return valve ⑩, and passes around the edges of the primary cup to fill the vacuum. When the piston has returned to its rest position against the stop, the small relief port is uncovered. As the brake fluid returns from the line, excess fluid passes through the relief port into the reservoir until the brake line pressure returns to zero.

holes at the bottom: a relatively large supply port ③ to supply fluid to the lines and a small relief port ② to admit excess fluid from the line. The primary and secondary cups stop the fluid from leaking back around the piston while the piston is moving forward to pressurize the line. The non-return valve is in the head of the piston; it stops backward fluid flow when the brake is applied. When the brake lever is released, the valve allows flow around the cup to fill the vacuum in front of the piston so that the piston can return easily.

Master Cylinder

The master cylinder assembly includes the reservoir ⑤, piston ⑩, primary and secondary cups ⑧, ⑪, non-

Master cylinder part wear

When master cylinder parts are worn or damaged, proper brake fluid pressure cannot be obtained in the line, and the brake will not hold.

If the small relief port becomes plugged, especially with a swollen or damaged primary cup, the brake pads will drag on the disc.

●Check that there are no scratches, rust or pitting on the inside of the master cylinder, and that it is not

202 MAINTENANCE—CHASSIS

Front and Rear Master Cylinders

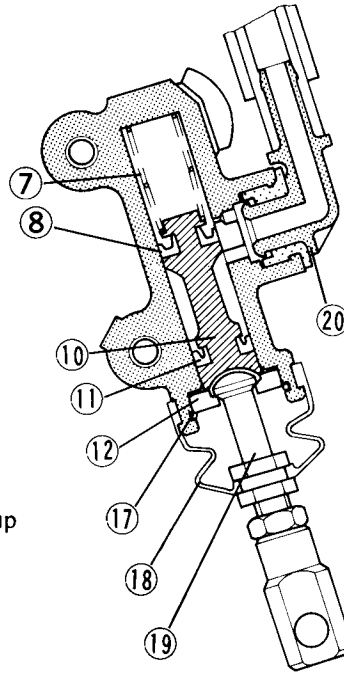
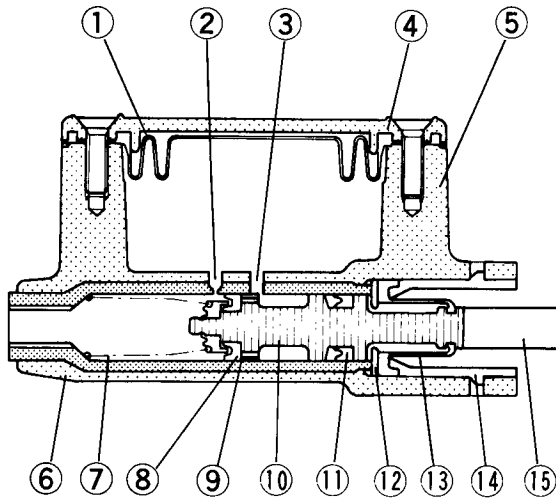

J30

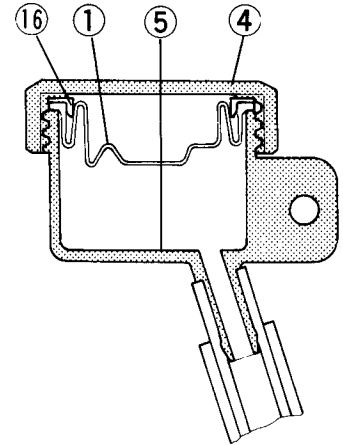

- | | |
|-------------------------|-------------------|
| 1. Diaphragm | 11. Secondary Cup |
| 2. Relief Port | 12. Piston Stop |
| 3. Supply Port | 13. Dust Seal |
| 4. Cap | 14. Liner |
| 5. Reservoir | 15. Brake Lever |
| 6. Master Cylinder Body | 16. Plate |
| 7. Spring | 17. Retainer |
| 8. Primary Cup | 18. Dust Cover |
| 9. Non-return Valve | 19. Push Rod |
| 10. Piston | 20. Connector |

- Check the piston for these same faults.
- Measure the cylinder inside diameter, and measure the piston, primary cup, and secondary cup outside diameter.

- Inspect the primary and secondary cups. If a cup is worn, damaged, softened (rotted), or swollen, replace it. If fluid leakage is noted at the brake lever, the cups should be replaced.

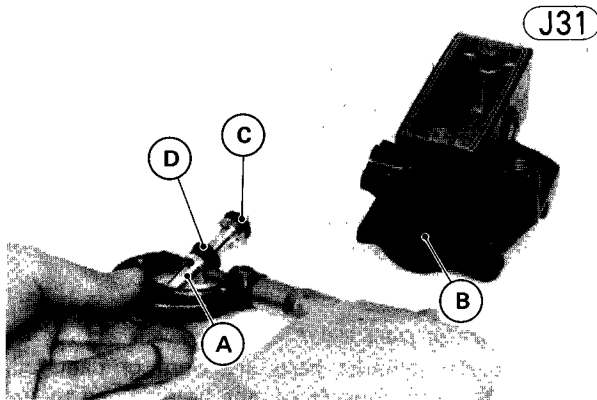

- | | |
|-------------|------------------|
| A. Piston | C. Primary Cup |
| B. Cylinder | D. Secondary Cup |

NOTE: The cups and spring are part of the piston assembly. Replace the piston assembly if any one of

Front

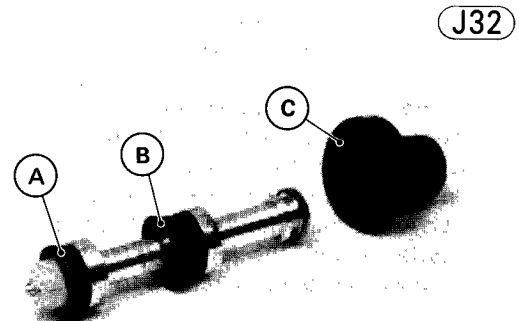

A. Primary Cup

C. Dust Cover

Rear

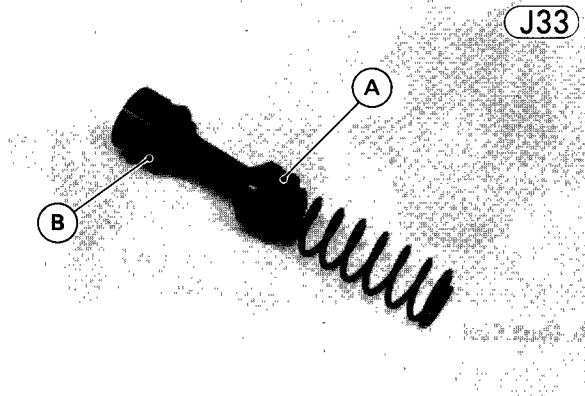

A. Primary Cup B. Secondary Cup

- Replace the dust seal if damaged.
- Check that the spring is not damaged and the spring free length is not shorter than the service limit.

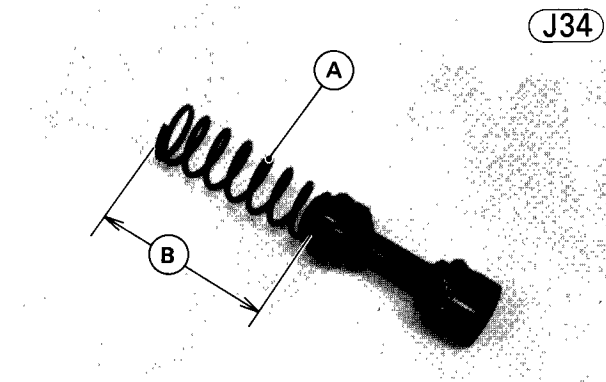

A. Spring B. Free Length

Table J10 Master Cylinder Parts

	Measurement	Service Limit
Front	Cylinder Inside Diameter	15.95 mm
	Piston Outside Diameter	15.80 mm
	Primary Cup Diameter	16.0 mm
	Secondary Cup Diameter	16.4 mm
	Spring Free Length	34.7 mm
Rear	Cylinder Inside Diameter	14.08 mm
	Piston Outside Diameter	13.77 mm
	Primary Cup Diameter	14.1 mm
	Secondary Cup Diameter	14.5 mm

Caliper

The front and rear wheel has a floating-type caliper. The caliper assembly includes two pads (7), and the piston (10), which is inside the caliper cylinder. Through the caliper run two shafts (2), which also pass through the caliper holder (1) to mount the assembly to the fork leg. When the piston forces the piston side pad against the disc, the shaft portion of the caliper assembly slides through the holder such that the another pad is also forced against the disc, both brake pads being kept parallel to the disc.

Front Caliper

J35

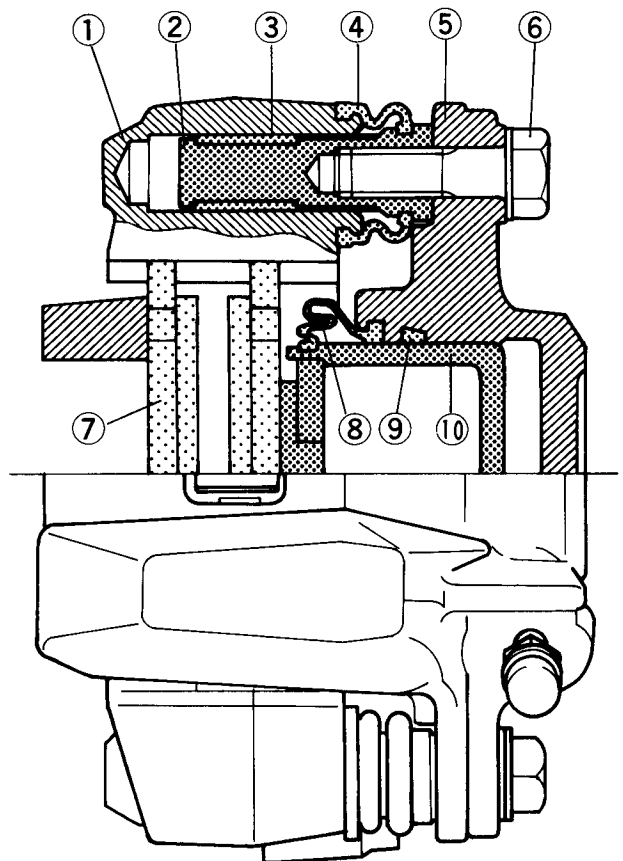

- | | |
|-------------------|----------------------|
| 1. Caliper Holder | 6. Holder Shaft Bolt |
| 2. Holder Shaft | 7. Pad |
| 3. Friction Boot | 8. Dust Seal |
| 4. Dust Cover | 9. Fluid Seal |
| 5. Caliper | 10. Piston |

Pad wear

Inspect the pads for wear. Check the thickness of the pad linings, and replace both pads as a set if the thickness of either pad is less than 1 mm.

If any grease or oil spills on the pads, wash it off with trichloroethylene or a high flash-point solvent. Do not use one which will leave an oily residue. If the oil

204 MAINTENANCE—CHASSIS

Brake Pad

J36

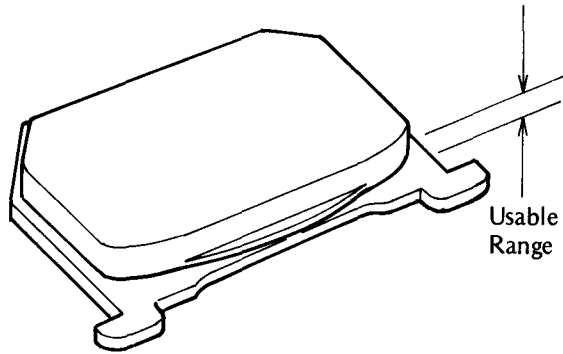

Fluid seal damage

The fluid seal around the piston maintains the proper pad/disc clearance. If this seal is not satisfactory, pad wear will increase, and constant pad drag on the disc will raise brake and brake fluid temperature.

Replace the fluid seals under any of the following conditions: (a) fluid leakage around the pad; (b) brakes overheat; (c) there is a large difference in left and right pad wear; (d) the seal is stuck to the piston. If the fluid seal is replaced, replace the dust seal as well. Also, replace all seals every other time the pads are changed.

J37

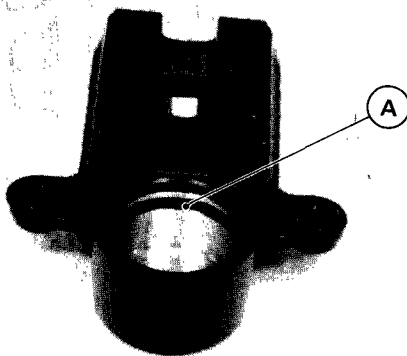

A. Fluid Seal

Dust seal damage

Check the dust seals, and replace any that are

J38

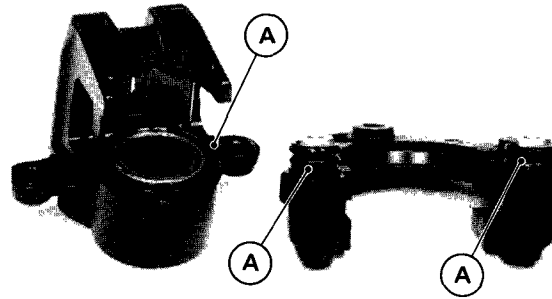

A. Dust Seal

Piston, cylinder wear

Measure the cylinder inside diameter and piston outside diameter.

Replace the cylinder and piston if they are worn out of tolerance, badly scored, or rusty.

J39

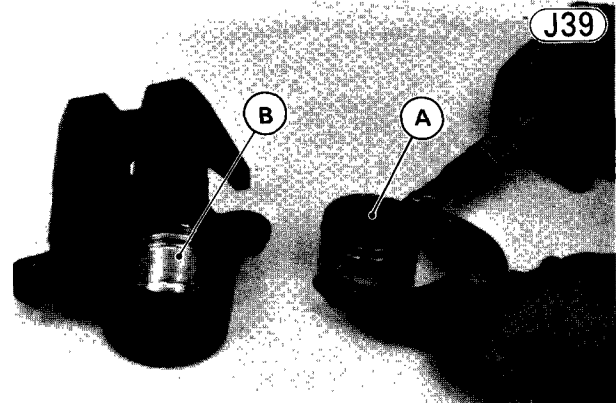

A. Piston

B. Cylinder

Table J11 Caliper Parts

Measurement	Service Limit
Cylinder Inside Diameter	42.92 mm
Piston Outside Diameter	42.75 mm

Caliper holder shaft wear

Caliper holder shafts must slide smoothly in the caliper holder. If the shafts do not slide smoothly, one pad will wear more than the other, pad wear will increase, and constant drag on the disc will raise brake and

holder shafts are not badly worn or stepped, or rubber friction boot are not damaged. If the shafts or rubber friction boot are damaged, replace the shafts, rubber friction boot, and the caliper holder.

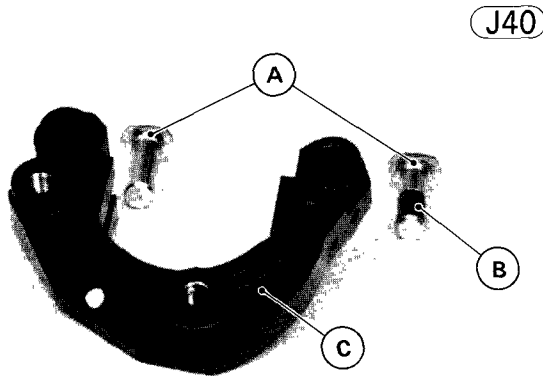

A. Caliper Holder Shafts
B. Friction Boot
C. Caliper Holder

Brake Disc

Besides wearing down, the disc may warp. A warped disc will cause the brake pads to drag on the disc and will wear down both the pads and disc quickly. Dragging will also cause overheating and poor braking efficiency.

Disc warp

Jack up the motorcycle so that the front wheel is off the ground, and turn the handlebar fully to one side. Set up a dial gauge against the front disc as illustrated, and measure disc runout. Remove the jack, set the motorcycle up on its center stand, and then measure the rear disc runout. If runout exceeds the service limit, replace the disc.

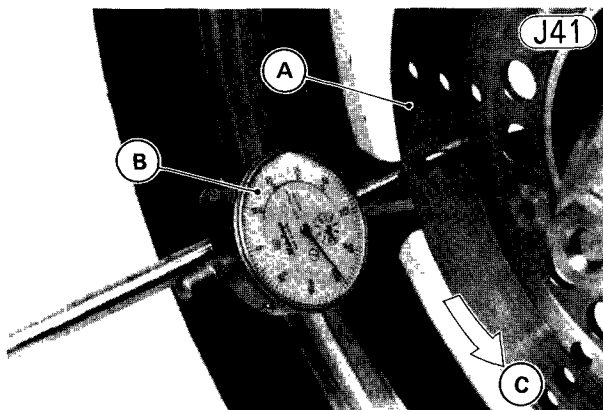

A. Disc
B. Dial Gauge
C. Turn.

Table J12 Disc Runout

--	--

Disc wear

Measure the thickness of each disc at the point where it has worn the most. Replace the disc if it has worn past the service limit.

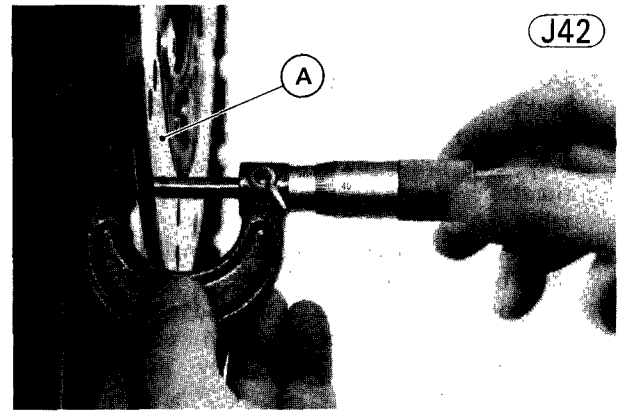

A. Disc

Table J13 Disc Thickness

	Front	Rear
Service Limit	4.5 mm	6.0 mm

Disc cleaning

Poor braking can also be caused by oil on the disc. Oil on the disc must be cleaned off with trichloroethylene or a high flash-point solvent. Do not use one which will leave an oily residue.

Brake Fluid

The brake fluid is an extra heavy duty type with a high boiling point to withstand the heat produced by friction of the caliper pads on the disc. Since the boiling point and thus the performance of the fluid would be reduced by contamination with water vapor or dirt from the air, the reservoir is sealed with a rubber diaphragm under the cap. This cap seal also prevents fluid evaporation and spillage should the motorcycle fall over. The fluid is further protected by rubber seals in the caliper assembly and at the master cylinder brake line fitting.

When the brake is applied, heat is generated by the friction between the disc and the brake pads. While much of this heat is immediately dissipated, some of it is transmitted to the brake fluid and may raise fluid temperature to as high as 150°C (300°F) during brake operation. This temperature could boil the brake fluid and cause a vapor lock in the lines unless fluid with a high boiling point is used and has been kept from being contaminated with dirt, moisture, or a different type of fluid. Poor quality or contaminated fluid can also deteriorate from contact with the recommended brake

WARNING

When working with the disc brake, observe the precautions listed below.

1. Never reuse old brake fluid.
2. Do not use fluid from a container that has been left unsealed or that has been open a long time.
3. Do not mix two types of fluid for use in the brake. This lowers the brake fluid boiling point and could cause the brake to be ineffective. It may also cause the rubber brake parts to deteriorate. Recommended fluids are given in the table.

NOTE: The type of fluid originally used in the disc brake is not available in most areas, but it should be necessary to add very little fluid before the first brake fluid change. After changing the fluid, use only the same type thereafter.

Table J14 Recommended Disc Brake Fluid

Atlas Extra Heavy Duty
Shell Super Heavy Duty
Texaco Super Heavy Duty
Wagner Lockheed Heavy Duty
Castrol Girling-Universal
Castrol GT (LMA)
Castrol Disc Brake Fluid

The correct fluid will come in a can labeled D.O.T.3. Do not use fluid that does not have this marking.

4. Don't leave the reservoir cap off for any length of time to avoid moisture contamination of the fluid.
5. Don't change the fluid in the rain or when a strong wind is blowing.
6. Except for the disc pads and discs, use only disc brake fluid, isopropyl alcohol, or ethyl alcohol for cleaning brake parts. Do not use any other fluid for cleaning these parts. Gasoline, motor oil, or any other petroleum distillate will cause deterioration of the rubber parts. Oil spilled on any part will be difficult to wash off completely and will eventually reach and break down the rubber used in the disc brake.
7. When handling the disc pads or disc, be careful that no disc brake fluid or any oil gets on them. Clean off any fluid or oil that inadvertently solvent. Do not use one which will leave an oily residue. Replace the pads with new ones if they cannot be cleaned satisfactorily.
8. Brake fluid quickly ruins painted surfaces; any spilled fluid should be completely wiped up immediately.
9. If any of the brake line fittings or the bleed valve is opened at any time, the **AIR MUST BE BLED FROM THE BRAKE.**

The graph of Fig. J43 shows how brake fluid contamination with moisture lowers the fluid boiling point. Although not shown in the graph, the boiling point also lowers as the fluid gets old, is contaminated with dirt, or if two different types of brake fluid are mixed.

Brake Fluid Boiling Point

J43

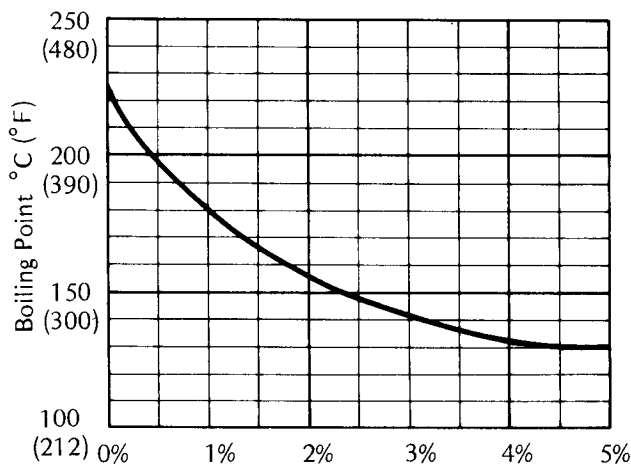

Changing the brake fluid

The brake fluid should be changed in accordance with the Periodic Maintenance Chart (Pg. 10) and whenever it becomes contaminated with dirt or water.

- Attach a clear plastic hose to the bleed valve on the caliper, and run the other end of the hose into a container.
- Remove the reservoir cap, and remove the rubber cap on the bleed valve.
- Open the bleed valve (counterclockwise to open), and pump the brake lever or pedal until all the fluid is drained from the line.
- If a dual disc brake is used, repeat the previous step one more time for the other side.
- Close the bleed valve(s), and fill the reservoir with fresh brake fluid.
- Open the bleed valve, apply the brake by the brake lever or pedal, close the valve with the brake held applied, and then quickly release the lever or pedal. Repeat this operation until the brake line is filled and fluid starts coming out of the plastic hose. Replenish the fluid in the reservoir as often as necessary to keep it from running completely out.
- Bleed the air from the lines.

Bleeding the brake

The brake fluid has a very low compression coef-

Filling up the Brake Line

J44

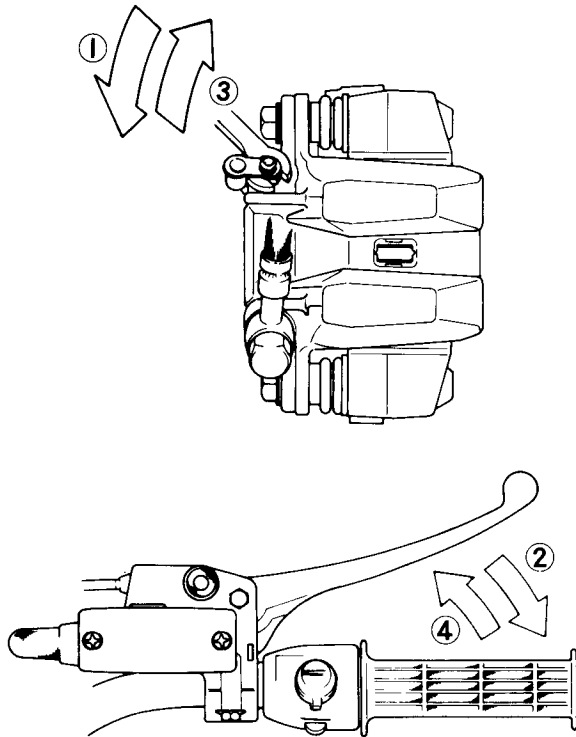

1. Open the bleed valve.
2. Apply the brake, keeping the brake applied.
3. Close the bleed valve.
4. Then quickly release the brake.

Bleeding the Brake Line

J45

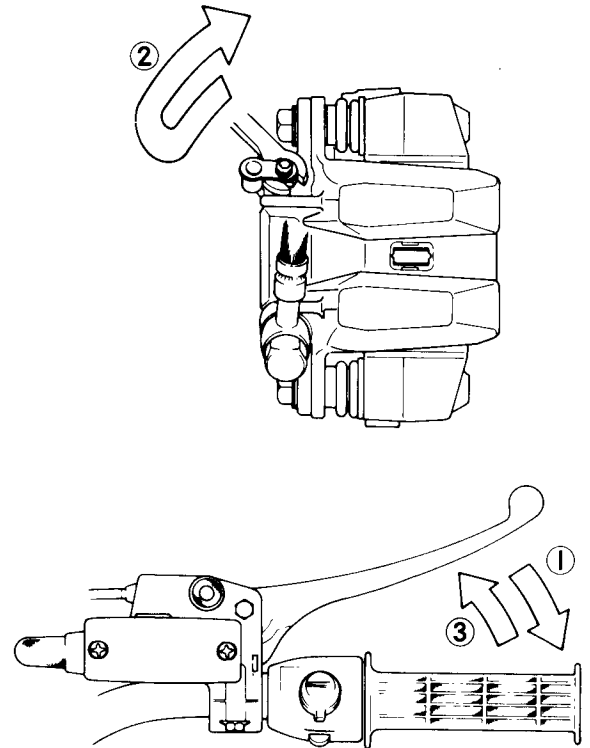

1. Hold the brake applied.
2. Quickly open and close the valve.
3. Release the brake.

lever or pedal is transmitted directly to the caliper for braking action. Air, however, is easily compressed. When air enters the brake lines, brake lever or pedal movement will be partially used in compressing the air. This will make the lever or pedal feel spongy, and there will be a loss in braking power.

Bleed the air from the brake whenever brake lever or pedal action feels soft or spongy, after the brake fluid is changed, or whenever a brake line fitting has been loosened for any reason.

- Remove the reservoir cap, and check that there is plenty of fluid in the reservoir. The fluid level must be checked several times during the bleeding operation and replenished as necessary. If the fluid in the reservoir runs completely out any time during bleeding, the bleeding operation must be done over again from the beginning since air will have entered the line.
- With the reservoir cap off, slowly pump the brake lever or pedal several times until no air bubbles can be seen rising up through the fluid from the holes at the bottom of the reservoir. This bleeds the air from the master cylinder end of the line.
- Install the reservoir cap, and connect a clear plastic hose to the bleed valve at the caliper, running the other end of the hose into a container. Pump the brake lever or pedal a few times until it becomes hard and then, holding the lever squeezed or the pedal pushed down,

bleed valve. Then release the lever or pedal. Repeat this operation until no more air can be seen coming out into the plastic hose. Check the fluid level in the reservoir every so often, replenishing it as necessary.

- If a dual disc brake is used, repeat the previous step one more time for the other side.
- When air bleeding is finished, install the rubber cap(s) on the bleed valve, and check that the brake fluid is filled to the upper level line marked in the reservoir (handlebar turned so that the reservoir is level).

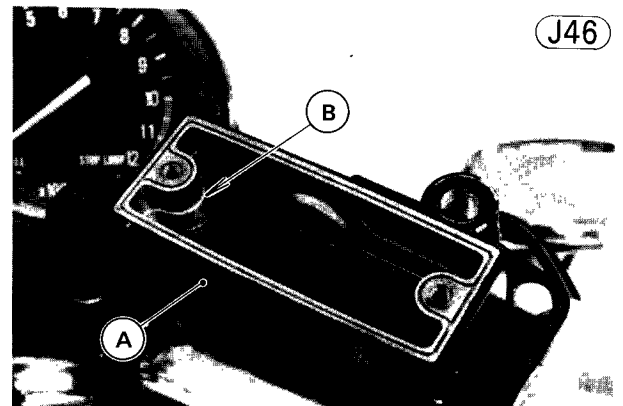

J46

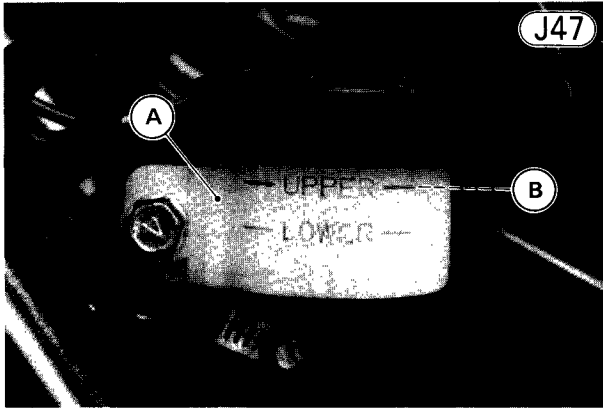

J47

A. Rear Master Cylinder B. Upper Level Line

Brake Hose

Brake line damage

The high pressure inside the brake line can cause fluid to leak or the hose to burst if the line is not properly maintained.

Bend and twist the rubber hose while examining it. Replace it if any cracks or bulges are noticed.

STEERING STEM

The steering stem supports the handlebar and front fork legs, and turns inside the frame head pipe. Ball bearings in the upper and lower ends of the head pipe enable the steering stem to turn smoothly and easily.

The steering stem itself does not wear, but it may become bent. If it becomes bent, the steering will be stiff, and the bearings may become damaged.

The steering stem will require periodic adjustment as it becomes loose due to bearing wear. Overtightening during adjustment, however, will make the steering stiff and cause accelerated bearing wear. Lack of proper lubrication will also bring about the same results.

From overtightening or from a heavy shock to the steering stem, the bearing race surfaces may become dented. Damaged bearing races will cause the handlebar to jerk or catch when turned.

Table J15 Bearing Ball Specifications

	Size	Quantity
Upper	¼"	19
Lower	¼"	20

Steering stem warp

Examine the steering stem, and replace it if it is bent.

Bearing wear, damage

Wipe the bearings clean of grease and dirt, and examine the races and balls. If the balls or races are worn, or if either race is dented, replace both races and all the

J48

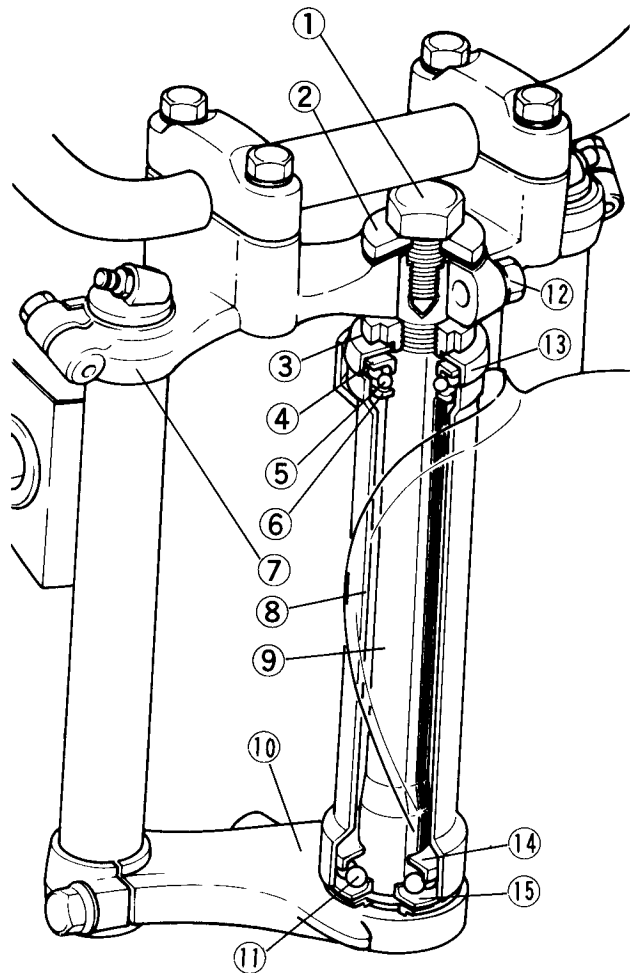

- 1. Stem Head Bolt
- 2. Flat Washer
- 3. Stem Locknut
- 4. Upper Inner Race
- 5. Steel Ball
- 6. Upper Outer Race
- 7. Stem Head
- 8. Frame Head Pipe
- 9. Steering Stem
- 10. Stem Base
- 11. Steel Ball
- 12. Head Clamp Bolt
- 13. Stem Cap
- 14. Lower Outer Race
- 15. Lower Inner Race

Bearing lubrication

In accordance with the Periodic Maintenance Chart (Pg. 10), and whenever the steering stem is disassembled, the steering stem bearings should be relubricated.

Wipe all the old grease off the races and balls, washing them in a high flash-point solvent if necessary. Replace the bearing parts if they show wear or damage. Apply grease liberally to the upper and lower races, and stick

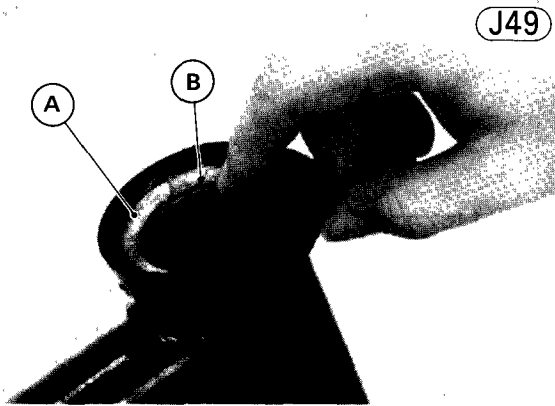

J49

A. Bearing Race B. Grease.

Grease seal deterioration, damage

Inspect the grease seal for any signs of deterioration or damage, and replace it if necessary.

Replace the grease seal with a new one whenever it has been removed.

FRONT FORK

The front fork legs of this model contain compressed air to obtain adjustable suspension. This type of the front fork is especially effective when the fork is compressed. It also has the advantage that any air pressure can be chosen (within the usable range) to suit various riding conditions.

Front Fork Load/Compression Stroke Relationship for KZ750-E US and Canadian models

J51

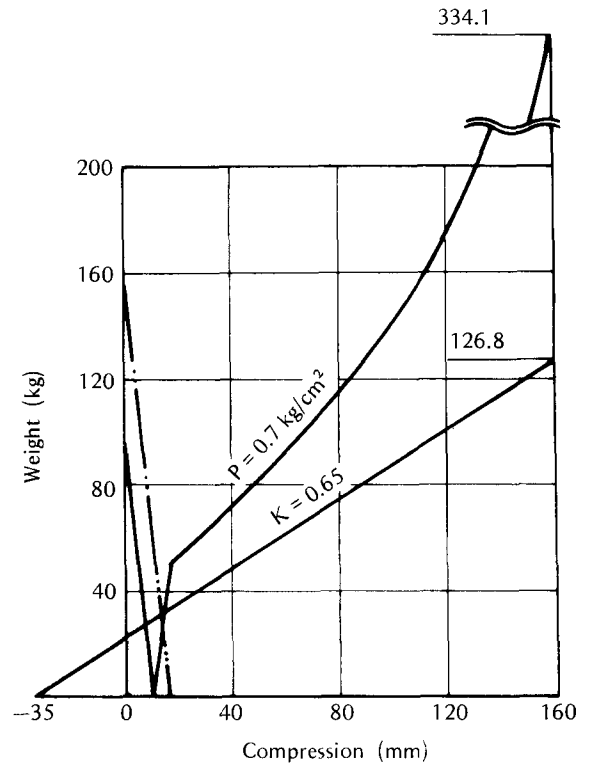

Front Fork Load/Compression Stroke Relationship for KZ750-E except for US and Canadian models

Front Fork Load/Compression Stroke Relationship for KZ750-H

J50

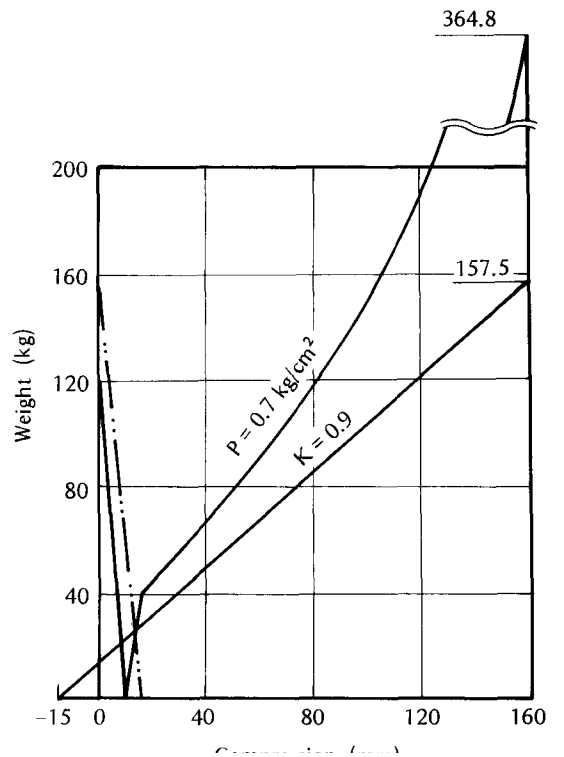
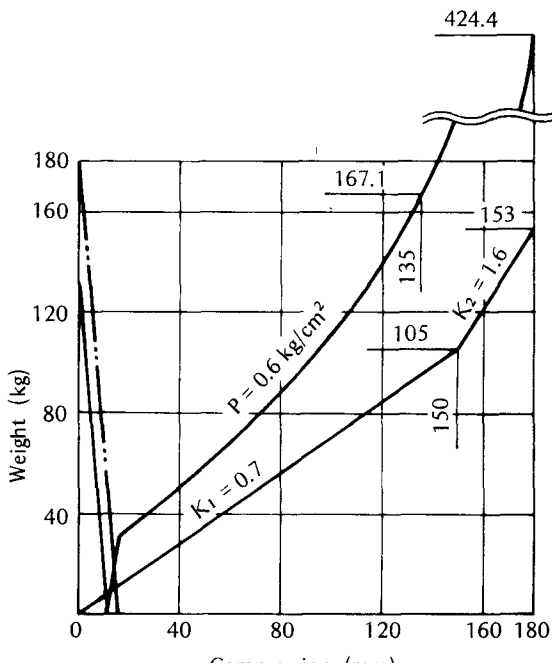

210 MAINTENANCE—CHASSIS

Front fork consists of the fork legs connected to the frame head pipe by the stem base and stem head bracket. It accomplishes shock absorption through spring action, air compression in the inner tube, and resistance to the flow of the oil forced into the cylinder by tube movement.

Each fork leg is telescopic tube including an inner tube ⑤, outer tube ⑥, cylinder and piston unit ④, collar, and cylinder base ⑨. The inner tube fits into the outer tube, altering its position in the outer tube as the tube arrangement absorbs shocks. The cylinder is fixed to the bottom of the outer tube and the piston (equipped with a piston ring) is secured to the top of the cylinder. The collar (coupled with a non-return valve ⑩), fixed in the lower end of the inner tube, forms the upper part of the lower chamber and together with the piston helps seal the upper chamber. The collar and cylinder base configuration function to form an oil lock at the end of the compression stroke to prevent the inner tube from striking the bottom. Small orifices in the upper part of the cylinder bring about an oil lock at the end of the extension stroke to prevent the inner tube from striking the top.

WARNING Do not remove the springs and rely on compressed air only. Correct springs must be used in this suspension system. Use without springs can lead to a condition causing accident and injury.

Compression Stroke

Whenever a load is placed on the front fork and whenever the front wheel receives a shock, the inner tube ⑤ moves down inside the outer tube ⑥, or the outer tube moves up, compressing both the spring ③ and the air in the inner tube. At the same time, low pressure (suction) is created in an enlarging chamber (upper chamber ⑦) formed between the inner tube and the cylinder ④, and oil is drawn in from a diminishing chamber (lower chamber ⑧) formed between the outer tube and the cylinder. As the lower chamber shrinks in size with oil passing freely through the non-return valve ⑩ into the upper chamber, oil also passes freely through the cylinder lower orifices into the cylinder as the inner tube approaches the cylinder base ⑨. Near the end of the compression stroke, the clearance between the tapered-out cylinder base and the collar at the lower end of the inner tube approaches zero. The resulting resistance to the flow of oil through this small space slows the movement, finally forming an oil lock to finish the compression stroke.

Extension Stroke

Following the compression stroke is the extension stroke, in which the compressed spring extends to push the inner tube back out of the outer tube. As the tubes move apart, the upper chamber grows smaller, forcing the oil through the way it came through the non-return valve. These small holes restrict the oil flow into the inner tube damping fork extension. Near the end of the extension stroke both the cylinder spring and the arrangement of the cylinder upper orifices provide further resistance to extension. As the collar rises, reducing orifices are eliminated and an oil lock forms, finishing

Compression Stroke

J52

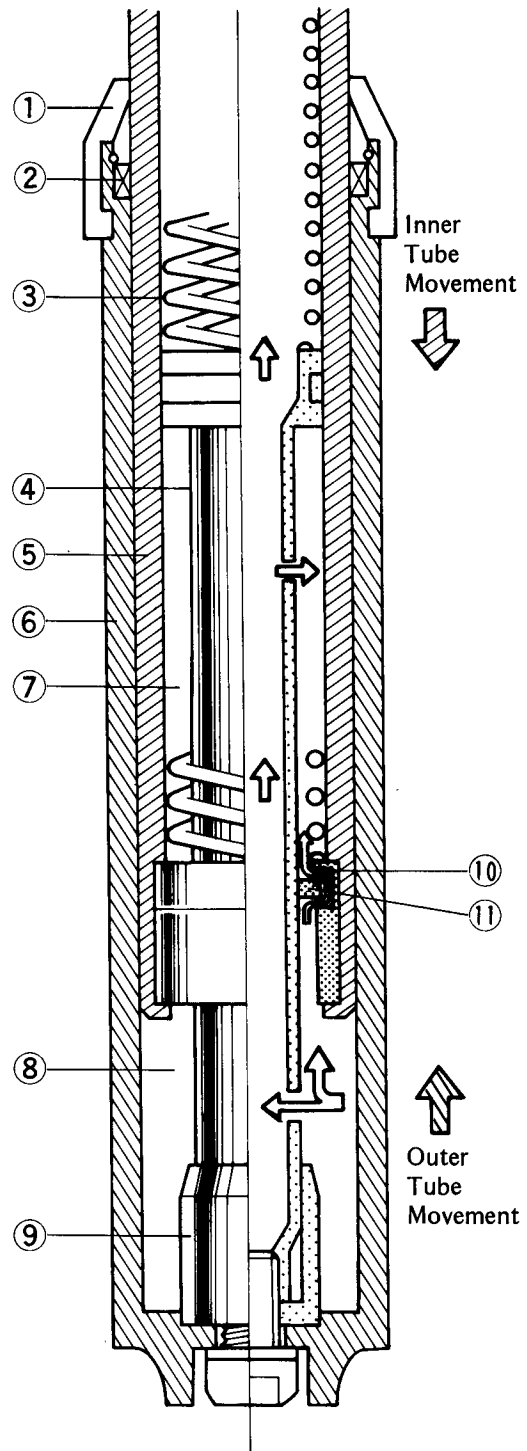

- | | |
|--------------------------------|------------------|
| 1. Dust Seal | 6. Outer Tube |
| 2. Oil Seal | 7. Upper Chamber |
| 3. Spring | 8. Lower Chamber |
| 4. Piston and
Cylinder Unit | 9. Cylinder Base |
| | 10. Spring |

Extension Stroke

J53

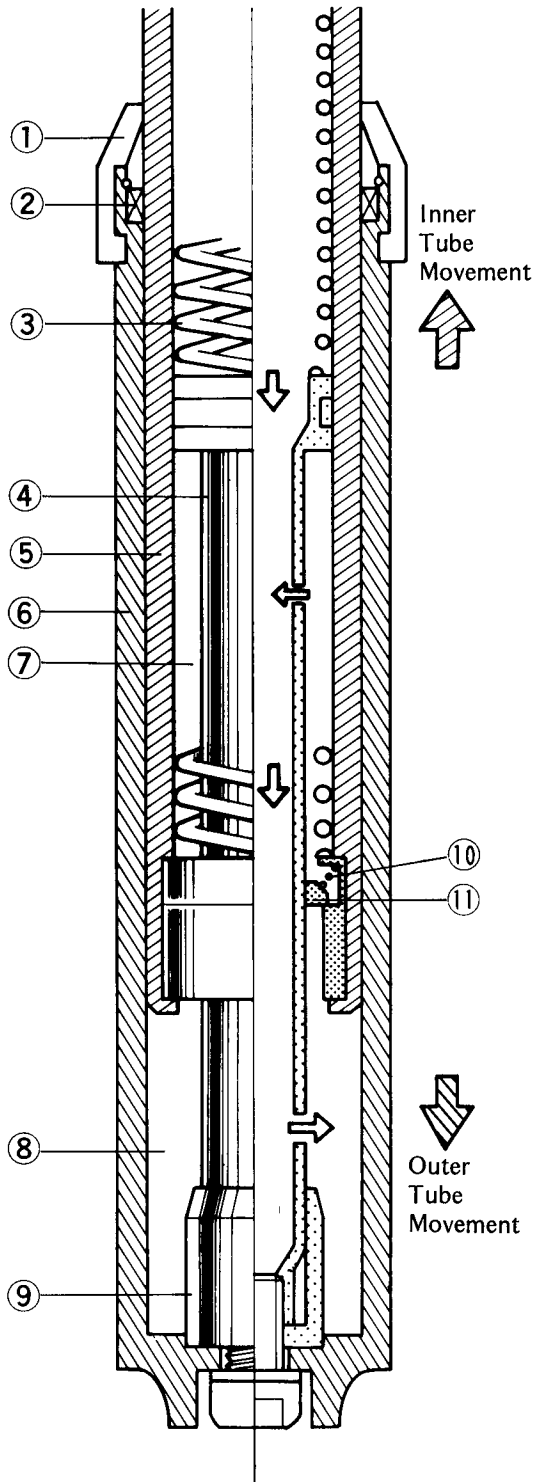

- | | |
|--------------------------------|------------------|
| 1. Dust Seal | 6. Outer Tube |
| 2. Oil Seal | 7. Upper Chamber |
| 3. Spring | 8. Lower Chamber |
| 4. Piston and
Cylinder Unit | 9. Cylinder Base |
| | 10. Spring |

Spring

The front fork springs in the inner tube are made of special spring rods, heated and wound in the shape of a special coil, to suspend the vehicle.

Spring tension

Since the spring becomes shorter as it weakens, check its free length to determine its condition. If the spring of either fork leg is shorter than the service limit, it must be replaced. If the length of a replacement spring and that of the remaining spring vary greatly, the remaining spring should also be replaced in order to keep the fork legs balanced for motorcycle stability.

J54

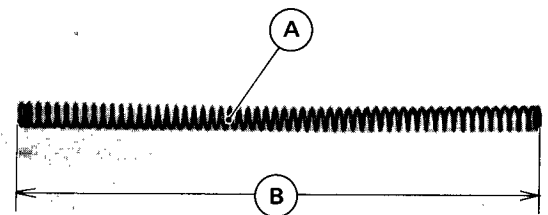

A. Fork Spring

B. Free Length

Table J16 Fork Spring Free Length

	KZ750-E	KZ750-H
Service Limit	497 (*477 mm)	483 mm

*Other than US and Canadian model

Inner Tube, Guide Bush

A bent, dented, scored, or otherwise damaged inner tube will damage the oil seal, causing oil leakage. A badly bent inner tube may cause poor handling.

Inner tube damage

Visually inspect the inner tube, and repair any damage. If the damage is not repairable, replace the inner tube. Since damage to the inner tube damages the oil seal, replace the oil seal whenever the inner tube is repaired or replaced. Temporarily assemble the inner and outer tubes, and pump them back and forth manually to check for smooth operation.

CAUTION If the inner tube is bent or badly creased replace it. Excessive bending follows

212 MAINTENANCE—CHASSIS

Guide bushing damage

Visually inspect the guide bushings, replace the inner tube assembly or outer tube assembly if it has badly damaged.

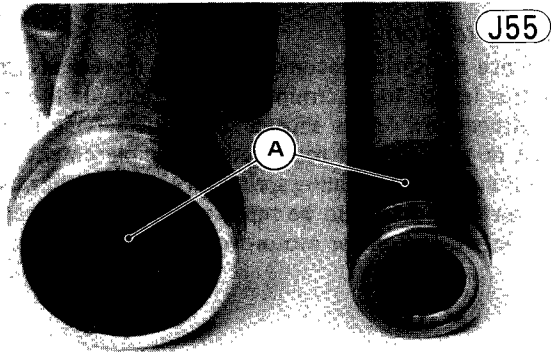

A. Guide Bushings

Oil Seal, Dust Seal

Oil is prevented from leaking out by the oil seal ②, which is fitted at the upper end of the outer tube. A dust seal ① on the outside of the tube keeps dirt and water from entering and damaging the oil seal and tube surface.

Inspection

Inspect the oil seal and dust seal for any signs of deterioration or damage, and replace them if necessary.

Replace the oil seal with a new one whenever it has been removed.

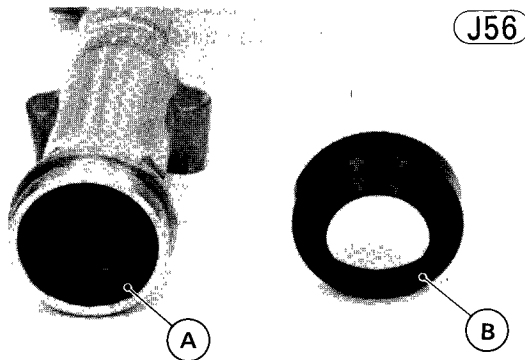

A. Oil Seal

B. Dust Seal

Fork Oil

Either too much or too little oil in the fork legs will adversely affect shock damping. Too much oil or

oil or too light an oil makes the action soft, decreases damping potential, and may cause noise during fork movement.

Contaminated or deteriorated oil will also affect shock damping and, in addition, will accelerate internal wear. The fork oil should be changed periodically (Pg. 10) or sooner if the oil appears dirty.

Fork oil change

- Put a motorcycle up on its center stand.
- Release air through the air valve at the top end of the front fork.
- Remove the handlebar off the stem head.
- Remove the drain screw from the lower end of the outer tube.

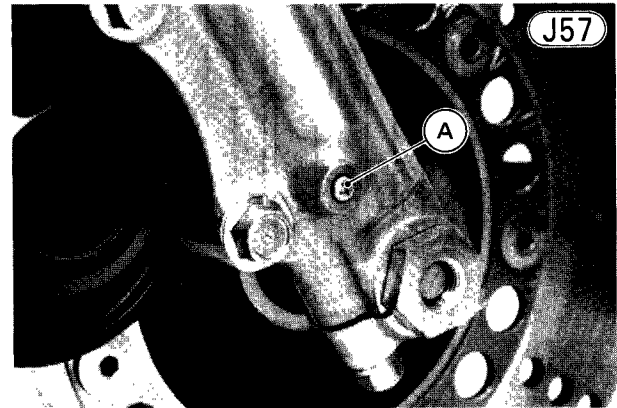

A. Drain Screw

- Pump out the oil by repeatedly compressing and extending the front fork.
- Wash the drain screw threads clean of oil, and blow them dry.
- Apply a liquid gasket to the thread of drain screw, and tighten the screw with its gasket.
- Remove the top plug, and remove the spring from the inner tube, and pour in the type and amount of oil specified in Table J17.

Table J17 Fork Oil

Type	Filling fork oil capacity		Oil level (without spring)
	When changing oil	After disassembly and completely dry	
KZ750-E	about 230 cc *215 cc	about 248 cc *232 cc	355 ± 4 mm *382 ± 4 mm from the top of the inner tube
KZ750-H	about 260 cc	about 280 cc	436 ± 4 mm from the top of the inner tube

- Pump the fork by several times to expel the air from the upper and lower chambers.
- Place a jack or stand under the engine so that the front wheel is raised off the ground.
- Insert a rod down into the tube, and measure the distance from the top of the inner tube to the oil level.

Fork Oil Level Measurement

J58

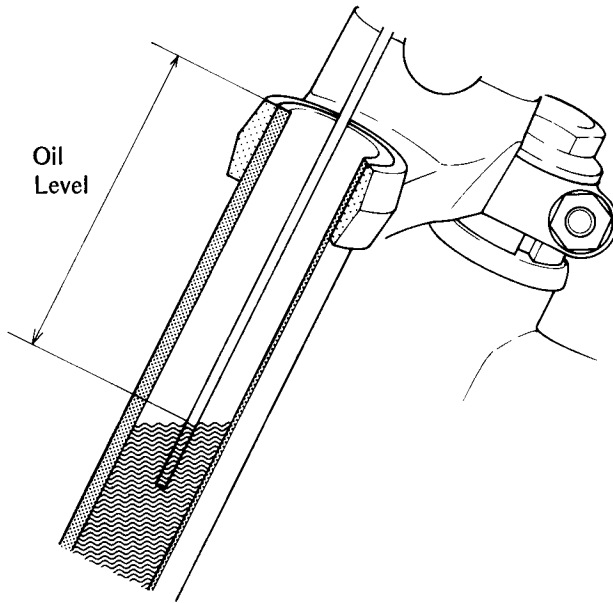

- If the oil is below the correct level, add enough oil to bring it up to the proper level, taking care not to over-fill.

CAUTION The operation of air front forks is especially dependent upon correct oil level. Higher level than specified may cause oil leakage and seal breakage. So be sure to maintain the specified level.

- Inspect the O ring on the top plug, and replace it with a new one if it is damaged.
- Install the spring and top plug, and fit the retainer.
- Change the oil of the other fork leg in the same manner.
- Install the handlebar (Pg. 137).
- Adjust the front fork air pressure (Pg. 22).

REAR SHOCK ABSORBER

The rear shock absorbers serve to damp shocks transmitted to the frame and rider from the rear wheel. For this purpose, they are connected between the frame and the rear end of the swing arm. Shock absorption is performed by the spring and by the resistance to the flow of oil inside each unit. Shock absorption is further aided by the use of rubber bushings in both the upper

Shock Absorber Spring Force for KZ750-E US and Canadian models and for KZ750-H except for US and Canadian models

J59

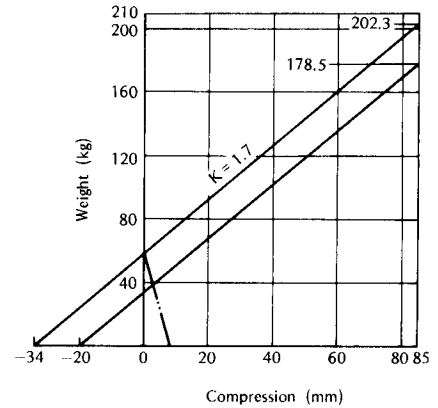

Shock Absorber Spring Force for KZ750-E except for US and Canadian models

J60

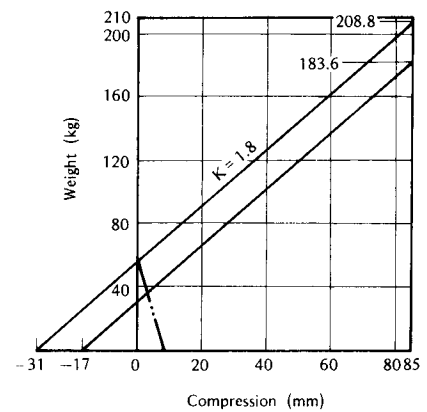

Shock Absorber Spring Force for KZ750-H US and Canadian models

J61

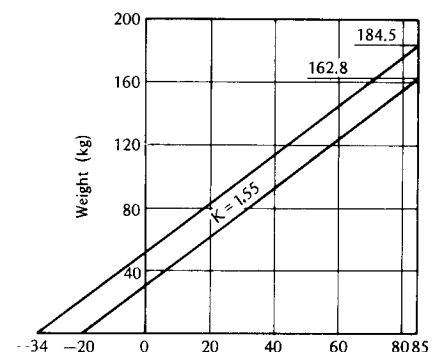

214 MAINTENANCE—CHASSIS

Rear Shock Absorber

J62

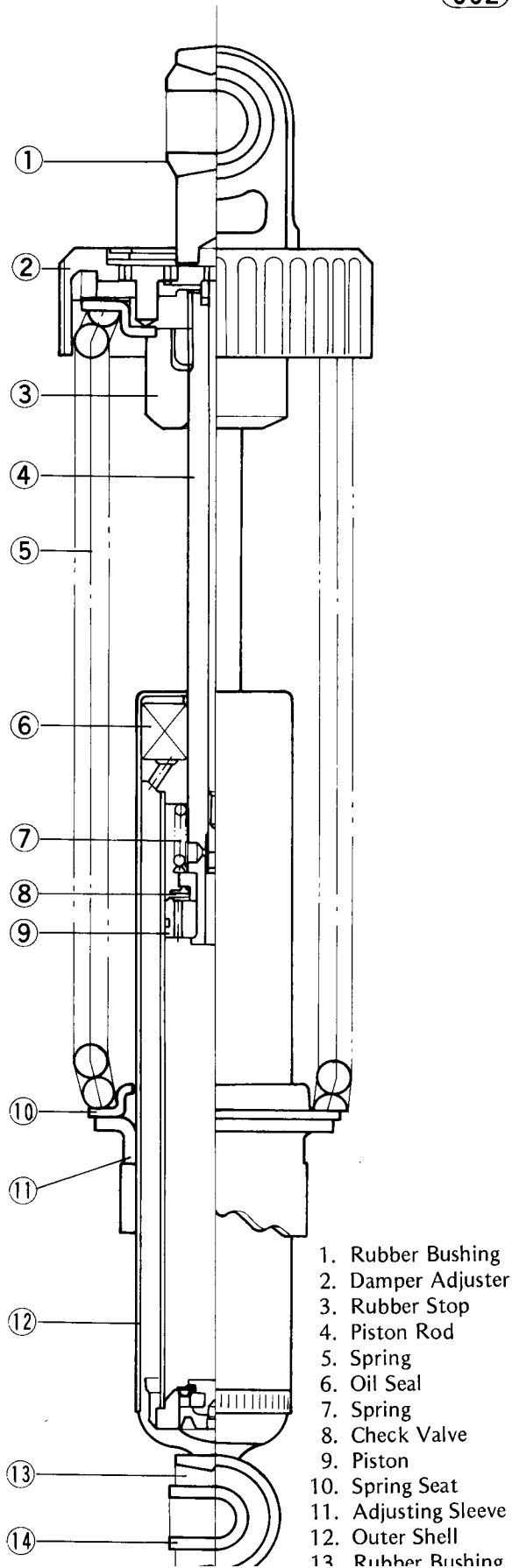

Table J18 Shock Absorber Damping Force

Setting Range	Damping Force kg (0.3 m/s, Expansion)	
	KZ750-E	KZ750-H
1	60 ± 12	34 ± 6
2	72 ± 14	42 ± 8
3	84 ± 17	50 ± 10
4	96 ± 19	62 ± 12

Since the rear shock absorbers are sealed units which cannot be disassembled, only external checks of operation are necessary. With the shocks removed, compress each one and see that the compression stroke is smooth and that there is damping in addition to spring resistance to compression. When the unit is released, the spring should not suddenly snap it to full length. It should extend smoothly with notable damping. When the shock absorber is operated, there should be no oil leakage. If either shock absorber does not perform all of these operations satisfactorily, or if one unit feels weaker than the other, replace both shock absorbers as a set. If only one unit is replaced and the two are not balanced, motorcycle instability at high speeds may result.

Shock absorber spring force for the 5 difference settings is shown in graph of Fig. J59 and J60, and the damping force for the 4 difference settings is shown in Table J18.

Bushing inspection

Check the rubber bushings, and replace any that are worn, cracked, hardened, or otherwise damaged.

SWING ARM

The swing arm is designed to work with the shock absorbers to dampen the shock to the frame from the rear wheel. The rear of the swing arm is connected to the frame by the rear shock absorbers, while the front end pivots on a shaft connected to the frame. When the rear wheel receives a shock, the swing arm, pivoting on its shaft, allows the wheel to move up and down in relation to the frame within the limits of the shock

Swing Arm

J63

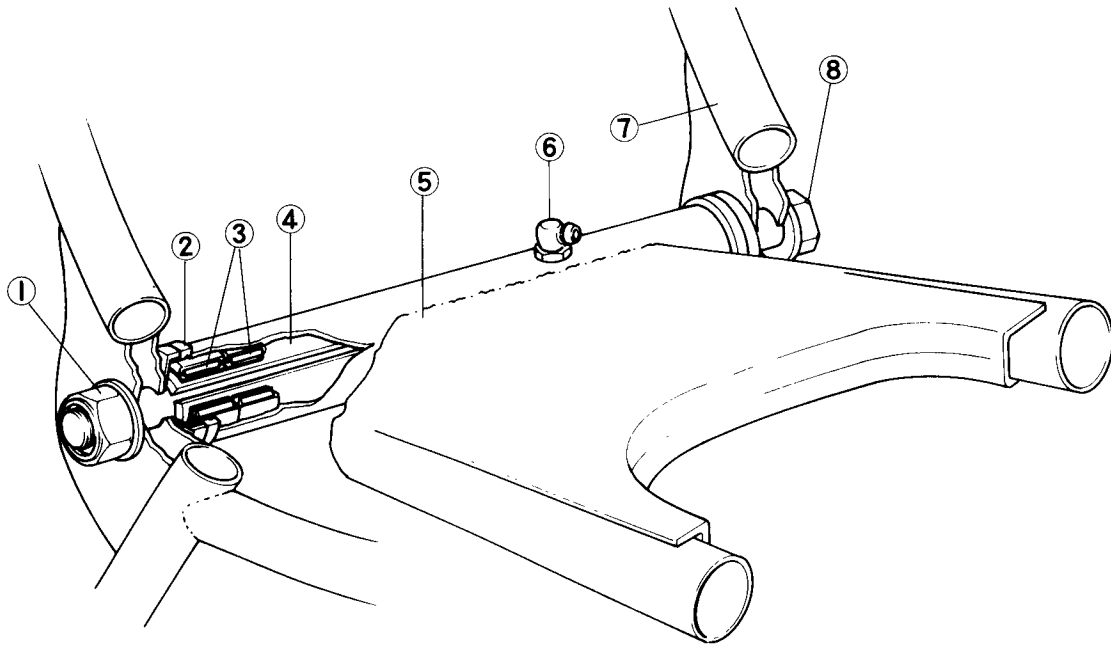

- 1. Pivot Shaft Nut
- 2. Cap
- 3. Needle Bearings

- 4. Sleeve
- 5. Swing Arm
- 6. Grease Nipple

- 7. Frame
- 8. Pivot Shaft

This motorcycle has needle bearings at the swing arm pivot. If bearing wear has progressed such that the swing arm has become loose, the motorcycle will be unstable. To minimize wear, the swing arm should be kept properly lubricated.

A bent pivot shaft or twisted swing arm will also cause instability by throwing the rear wheel out of alignment. A bent pivot shaft may also cause bearing seizure.

Swing arm bearing wear

Measure the outside diameter of the swing arm sleeve at both ends with a micrometer. Replace the swing arm sleeve if the diameter is less than the service limit or if it shows visible damage.

Table J19 Swing Arm Sleeve

Service Limit	21.96 mm
---------------	----------

The rollers in the needle bearings wear so little that the wear is difficult to measure. Instead, inspect the needle bearings for abrasions, color change, or other damage. If there is any doubt as to its the condition of either needle bearing, replace both needle bearings. Whenever the swing arm sleeve is replaced, also replace the needle bearings.

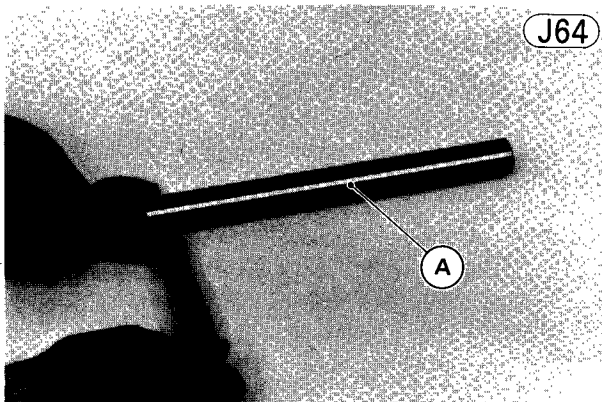

Swing arm lubrication

There is a grease nipple on the swing arm for lubrication. Grease the swing arm with regular cup grease with the frequency given in the Periodic Maintenance Chart (Pg. 10). Force the grease into the nipple until it comes out at both sides of the swing arm, and wipe off any excess. If the grease does not come out, first check that the nipple is not clogged with dirt or old grease. If the nipple is clear but still will not take grease; remove the swing arm (Pg. 143), pull out the sleeve, clean out the old grease, and apply grease to the needle

216 MAINTENANCE—CHASSIS

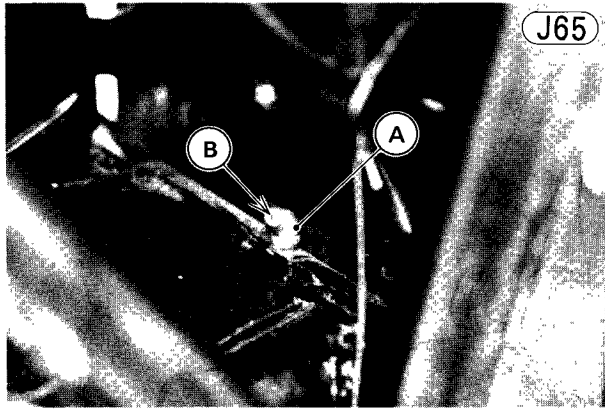

A. Grease Nipple

B. Grease.

Table J20 Pivot Shaft Runout

Service Limit	Repair Limit
0.14 mm	0.7 mm

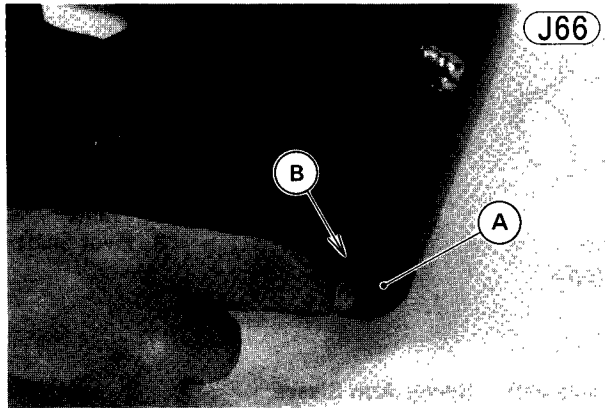

A. Needle Bearing

B. Grease.

Pivot shaft runout measurement

To measure the pivot shaft runout, set the pivot shaft on V blocks at the end of the pivot shaft, and set a dial gauge to the shaft halfway between the blocks. Turn the shaft to measure the runout. The amount of runout is the amount of dial variation. If the shaft runout exceeds the service limit, straighten it. If it cannot be straightened, or if the runout exceeds the repair limit, replace the shaft.

Pivot Shaft Runout

J67

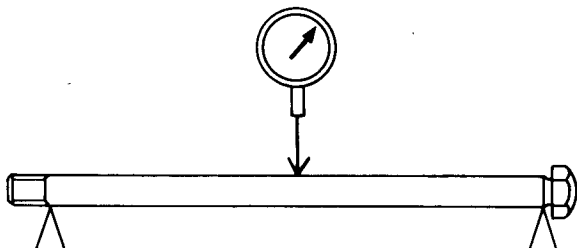

Maintenance—Electrical

Table of Contents

BATTERY	218
CHARGING SYSTEM	220
Alternator	220
Regulator/Rectifier	221
Charging System Inspection	223
IGNITION SYSTEM	225
Pick-up Coil	225
IC Igniter	226
Ignition Coil	226
Timing Advancer	227
Spark Plug	227
Description of Each Testing Procedure	229
ELECTRIC STARTER SYSTEM	232
Starter Motor Circuit	232
Starter Motor	234
Starter Motor Clutch	236
IGNITION SWITCH	237
NEUTRAL SWITCH	238
LIGHTING SYSTEM	238
Headlight Circuit and Reserve Lighting System	238
Tail/Brake Light Circuit	242
Turn Signal and Hazard Circuit	245
HORN	247
LOW FUEL WARNING SYSTEM	248
VOLTMETER	249
SPEEDOMETER, TACHOMETER	249

218 MAINTENANCE—ELECTRICAL

BATTERY

The battery supplies the current to the starter motor and serves as a back-up source of power to operate the electrical equipment whenever the engine is turning over too slowly for the alternator to supply sufficient power.

With proper care, the battery can be expected to last several years, but it may be completely ruined long before that if it is mistreated. Following a few simple rules will greatly extend the life of the battery.

1. When the level of the electrolyte in the battery is low, add only distilled water to each cell, until the level is at the upper level line marked on the outside of the battery. Ordinary tap water is not a substitute for distilled water and will shorten the life of the battery.
2. Never add sulphuric acid solution to the battery. This will make the electrolyte solution too strong and will ruin the battery within a very short time.
3. Avoid quick-charging the battery. A quick-charge will damage the battery plates.
4. Never let a good battery stand for more than 30 days without giving it a supplemental charge, and never let a discharged battery stand without charging it. If a battery stands for any length of time, it slowly self-discharges. Once it is discharged, the plates sulphate (turn white), and the battery will no longer take a charge.
5. Keep the battery well charged during cold weather so that the electrolyte does not freeze and crack open the battery. The more discharged the battery becomes, the more easily it freezes.
6. Always keep the battery vent hose free of obstruction, and make sure it does not get pinched, crimped, or melted shut by contact with the hot muffler. If battery gases cannot escape through this hose, they will explode the battery.
7. DON'T INSTALL THE BATTERY BACKWARDS. The negative side is grounded.

Electrolyte

The electrolyte is dilute sulphuric acid. The standard specific gravity of the electrolyte is 1.280 at 20°C (68°F). The water in this solution changes to a gaseous mixture due to chemical action in the battery and escapes, which concentrates the acid in a charged battery. Consequently, when the level of the electrolyte becomes low, only distilled water should be added. If sulphuric acid is added, the solution will become too strong for proper chemical action and will damage the plates. Metal from the damaged plates collects in the bottom of the battery. This sediment will eventually cause an internal short circuit.

The specific gravity of the electrolyte is measured with a hydrometer and is the most accurate indication of the condition of the battery. When using the hydrometer, read the electrolyte level at the bottom of the meniscus (curved surface of the fluid). Fig. K2 shows the relationship between the specific gravity of the solution at 20°C (68°F) and the percentage of battery charge. Since specific gravity varies with temperature, and since the temperature of the solution being checked is likely to be other than 20°C (68°F); the formula given below should be used to compute the equivalent

temperature goes up, the specific gravity goes down, and vice versa.

Hydrometer

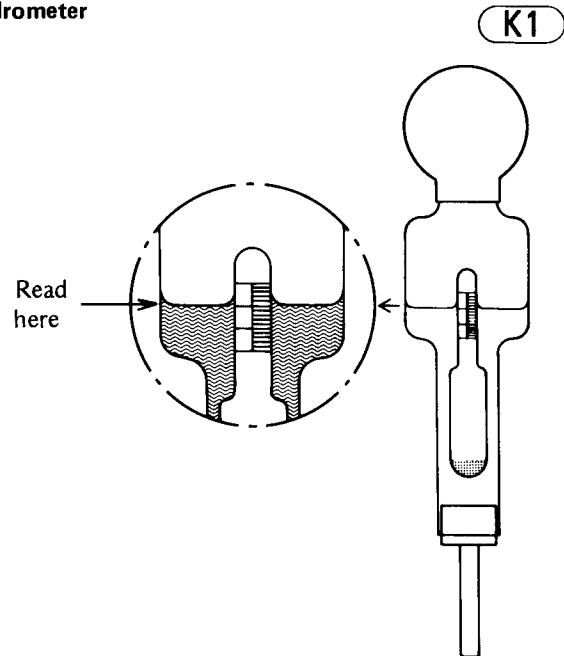

°Celsius

$$S_{20} = S_t + [0.0007 (t - 20)]$$

°Fahrenheit

$$S_{68} = S_t + [0.0004 (t - 68)]$$

S_t = specific gravity at the present temperature

S_{20} = specific gravity at 20°C

S_{68} = specific gravity at 68°F

t = present temperature of solution

Generally speaking, a battery should be charged if a specific gravity reading shows it to be discharged to 50% or less of full charge.

Specific Gravity/Battery Charge Relationship

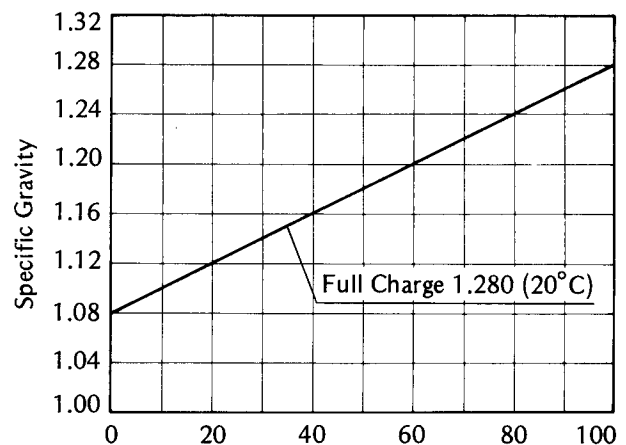

Initial charge

New batteries for Kawasaki motorcycles are dry charged and can be used directly after adding the electrolyte. However, the effect of the dry charge deteriorates somewhat during storage, especially if any air has entered the battery from imperfect sealing. Therefore, it is best to give the battery an initial charge before using it in order to ensure long battery life.

WARNING Because the battery gives off an explosive gas mixture of hydrogen and oxygen, keep any sparks or open flame away from the battery during charging.

●Pour a 1.280 (specific gravity at 20°C or 68°F) sulphuric acid solution into each cell of the battery up to the upper level line.

●Let the battery stand for 30 minutes, adding more acid if the level drops during this time.

NOTES: 1. If the temperature of the solution is over 30°C (85°F), cool the solution before pouring it into the battery.

2. After pouring the acid into the battery, start charging the battery within 12 hours.

●Leaving the caps off the cells, connect the battery to a charger, set the charging rate at 1/10 the battery capacity, and charge it for 10 hours. For example, if the battery is rated at 12AH, the charging rate would be 1.2 ampere. If a constant voltage charger is used, the voltage must be adjusted periodically to keep the current at a constant value.

CAUTION If the temperature of the electrolyte rises above 45°C (115°F) during charging, reduce the charging rate to bring down the temperature, and increase the charging time proportionately.

●After charging, check the electrolyte level in each cell. If the level has dropped, add distilled water to bring it back up to the upper level line.

●Check the results of charging by measuring the specific gravity of each cell and by measuring battery voltage. Battery voltage of a 12 volt battery directly after the completion of charging should be 15 to 16 volts.

Ordinary charge

WARNING Because the battery gives off an explosive gas mixture of hydrogen and oxygen, keep any sparks or open flame away from the battery during charging.

●Clean off the battery using a solution of baking soda and water. Make especially sure that the terminals are clean.

●If the electrolyte level is low in any cell, fill to over the lower level line but not up to the upper level line since the level rises during charging. Figure the charging rate to be between 1/10 and 3/10 of battery capacity. For example, the maximum charging rate for a 12AH battery would be 12 x 3/10 which equals 3.6 amperes.

CAUTION Charging the battery at a rate higher than specified above could ruin the battery. Charging at a higher rate causes excess heat, which can warp the plates and cause internal shorting. Higher than normal charging rates also cause the plates to shed active material. Deposits will accumulate, and can cause internal shorting.

●Measure the specific gravity of the electrolyte, and use the graph, Fig. K2, to determine the percentage of discharge. Multiply the capacity of the battery by the percentage of discharge to find the amount of discharge in ampere-hours. Use this figure in the formula below to compute charging time.

$$\text{Charging time (hours)} = \frac{\text{Amount of discharge (AH)}}{\text{charging current (A)}} \times 1.2 \sim 1.$$

●Remove the caps from all the cells, and begin charging the battery at the rate just calculated. If a constant voltage charger is used, the voltage will have to be adjusted periodically to maintain charging current at a constant value.

CAUTION If the temperature of the electrolyte rises above 45°C (115°F) during charging, reduce the charging rate to bring down the temperature, and increase charging time proportionately.

●After charging, check the electrolyte level in each cell. If the level has dropped, add distilled water to bring it back up to the upper level line.

●Check charging results by measuring the specific gravity of each cell and by measuring battery voltage. Battery voltage of a 12 volt battery directly after the completion of charging should be 15 to 16 volts and the specific gravity of the electrolyte should be more than 1.250. If the voltage is lower than this, the battery is not completely charged or can no longer take a full charge. If the specific gravity of any one cell is lower than 1.250, there may be damage in the cell.

Test charging

When the battery is suspected of being defective, first inspect the points noted in the table below. The

Table K1 Battery Troubleshooting Guide

	Good Battery	Suspect Battery	Action
Plates	(+) chocolate color (-) gray	white (sulphated); + plates broken or corroded	Replace
Sediment	None, or small amount	sediment up to plates, causing short	Replace
Voltage	above 12 volts	below 12 volts	Test charge
Electrolyte Level	above plates	below top of plates	Fill and test charge
Specific Gravity	above 1.200 in all cells; no two cells more than 0.020 different	below 1.100, or difference of more than 0.020 between two cells	Test charge

220 MAINTENANCE—ELECTRICAL

battery can be restored by charging it with the ordinary charge. If it will take a charge so that the voltage and specific gravity come up to normal, it may be considered good except in the following case:

★ If the voltage suddenly jumps to over 13 volts just after the start of charging, the plates are probably sulphated. A good battery will rise to 12 volts immediately and then gradually go up to 12.5 ~ 13 volts in about 30 to 60 minutes after charging is started.

★ If one cell produces no gas bubbles, or has a very low specific gravity, it is probably shorted.

★ If there does not appear to be enough sediment to short the plates, but one cell has a low specific gravity after the battery is fully charged, the trouble may be just that there is insufficient acid in that cell. In this instance only, sulphuric acid solution may be added to correct the specific gravity.

★ If a fully charged battery not in use loses its charge after 2 to 7 days, or if the specific gravity drops markedly, the battery is defective. The self-discharge rate of a good battery is only about 1% per day.

CHARGING SYSTEM

The charging system consists of an alternator and regulator/rectifier.

The alternator generates the current required by the electrical circuits. The generated current is a three phase alternating current (AC), which is changed to direct current (DC) and controlled by a solid-state regulator/rectifier to supply an even voltage to the circuit components.

Charging System

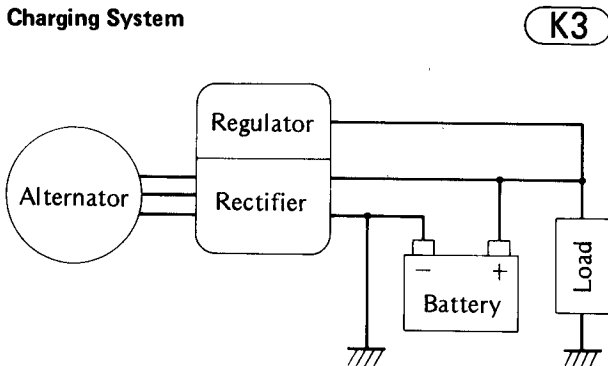

K3

There are a number of important precautions that are musts when servicing the charging system. Cautions that are applied to the individual sections are mentioned in each section. Failure to observe these rules can result in serious system damage. Learn and observe all the

CAUTION When handling the regulator/rectifier, observe the following to avoid damage to the regulator/rectifier.

1. Do not reverse the battery lead connections. This will burn out the zener diode.
2. For the regulator/rectifier to function properly, the battery must be charged to near capacity. If the battery is badly discharged, charge it before installing it in the motorcycle.

When handling the alternator rotor:

3. Do not allow the rotor to suffer sharp impacts such as striking it with a hammer or letting it fall on a hard surface. Such a shock to the rotor can cause the magnets to lose their magnetism.

Alternator

The alternator is made of a rotor (5) and stator coil (4). The stator coil is mounted in the alternator cover (1), while the rotor is secured to the left end of the crankshaft (2) and rotates at engine rpm. Permanent magnets in the rotor supply the magnetic field for the stator coil so that no slip rings or brushes are necessary, making the alternator practically maintenance free.

Alternator Construction

K4

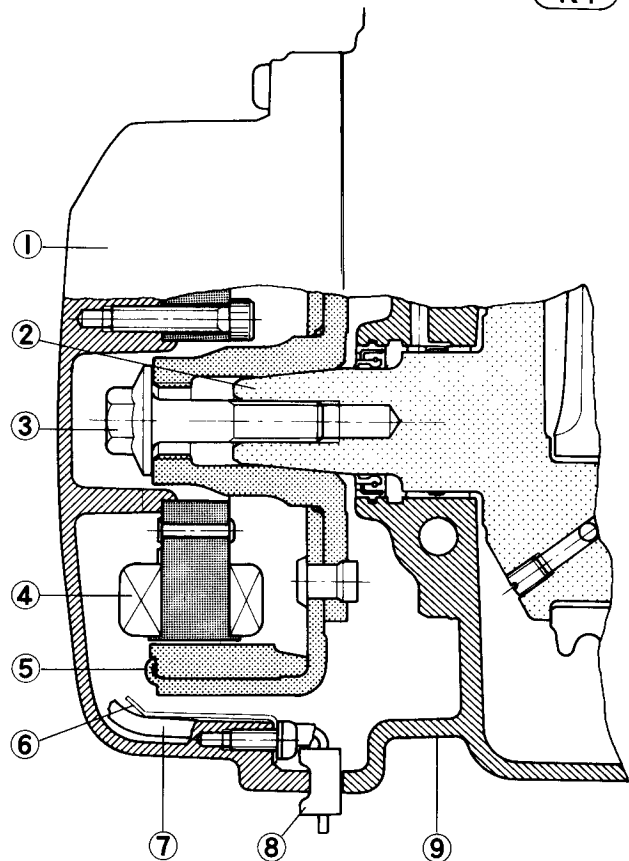

1. Alternator Cover
2. Crankshaft
3. Rotor Bolt
4. Alternator Stator

6. Wiring Clamp
7. Alternator Wiring
8. Grommet
9. Crankcase

The stator coil consists of three sets of coils wound on laminated steel cores. These coils are connected in a wye connection to produce a 3 phase alternating current. Since the voltages of these 3 phases overlap, there is a continuous, even supply of current for the circuit components.

Wye Connection

K5

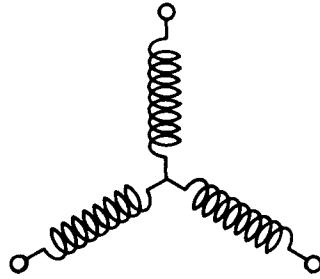

Alternator Current

K6

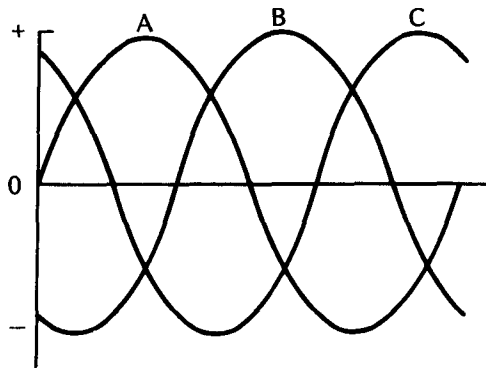

Regulator/Rectifier

The regulator and rectifier are solid-state type, and integrated into one unit. Since it contains no contacts or other moving parts, it does not wear out and never needs to be adjusted. It is therefore manufactured as a sealed unit, and must be replaced as a unit should it become defective. The rectifier in the unit rectifies (change to direct current, DC) the alternating current (AC) from the alternator. It contains four silicon diodes which are connected in a bridge circuit arrangement for efficient, full-wave rectification. The regulator in the unit keeps the battery (+) terminal voltage level to a maximum of the specified range. The control circuit in the diagram checks on the voltage level, and triggers the thyristors.

Though the actual regulator/rectifier circuit performs full-wave rectification, a simplified single-phase circuit of half-wave rectification is explained here to aid the technician in troubleshooting and in understanding test procedures. Fig. K11 shows the basic circuit of the regulator/rectifier. The main components of the regulator/rectifier circuit are a thyristor (Th), or Silicon Controlled Rectifier (SCR) as it is also called, and a diode. The diode, thyristor (Th), and zener diode (ZD) function as follows:

1. Diode

A current of electrons can flow only from the cathode to the anode of the diode. However, a defective diode will either conduct in both directions (a short) or not conduct at all (an open). If any of the diodes is shorted or open, the voltage from the regulator/rectifier will be below normal, and the battery may not be charged adequately.

Regulator/Rectifier

K7

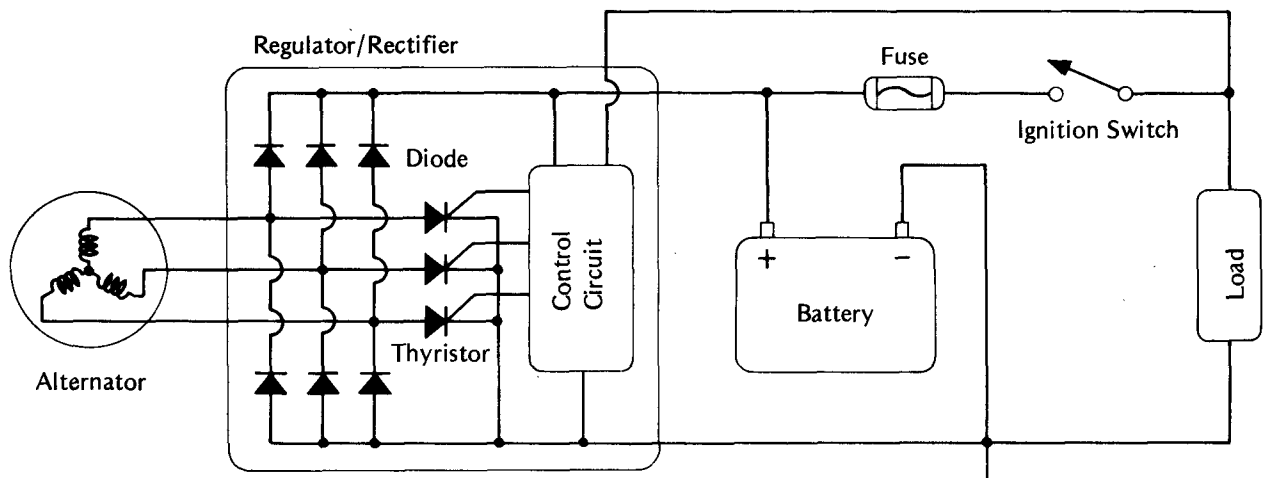

222 MAINTENANCE—ELECTRICAL

Diode Current Flow

K8

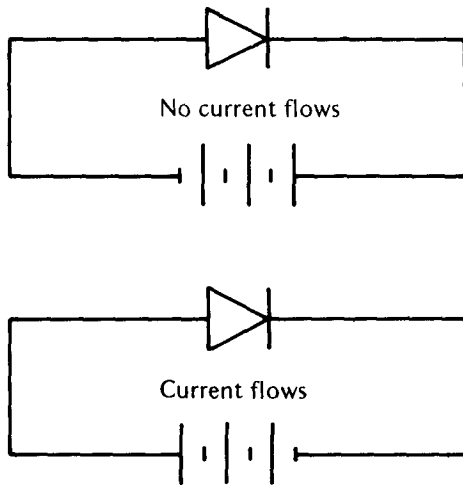

2. Thyristor

The current of electrons will flow from the cathode to the anode but will not flow in the reverse direction. The thyristor differs from a diode in two respects: (a) even through a voltage of the correct polarity (negative to cathode) may be applied, the thyristor will not conduct until a signal is received at the gate input lead; (b) once started, it will not stop conducting (even if the gate lead signal voltage stops) until the anode to cathode voltage is removed or reversed.

Thyristor

K9

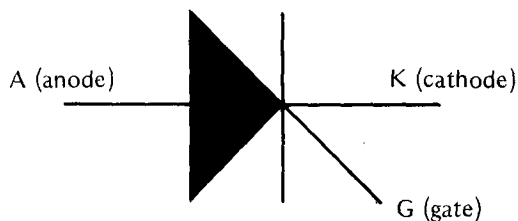

3. Zener diode

As in a normal diode, current will flow easily from the cathode to anode, and will not usually flow in the opposite direction. Unlike a normal diode, however, the zener diode will "break down", or conduct in the reverse direction, if enough voltage is applied in the reverse direction. When this voltage is lowered or removed, the diode will stop conducting and return to its normal state. The voltage at which the diode begins reverse conduction, is called the breakdown voltage, and is set at the desired level when the diode is manufactured. This property of the zener diode

Zener Diode

K10

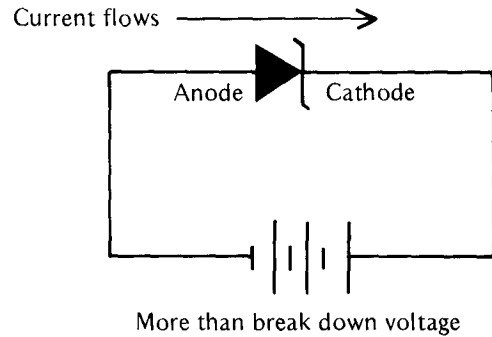

In the regulator/rectifier circuit, the diode is connected in series with the alternator to rectify the alternator output, and the thyristor is connected in parallel with the alternator. Detailed circuit operation is as follows:

When the battery voltage is lower than the specified value, the zener diode does not conduct and the control unit does not trigger the thyristor. At this time, the thyristor does not conduct, and all alternator output current flows through the battery and loads to supply adequate charging current.

When the battery voltage is equal to or higher than the predetermined voltage, the zener diode conducts and the control unit signals the thyristor to start conducting. Then, instead of current going through the battery and overcharging it, it flows through the thyristor and then directly back to the alternator.

Basic Regulator/Rectifier Circuit

K11

1. When battery voltage is low (Thyristor is off).

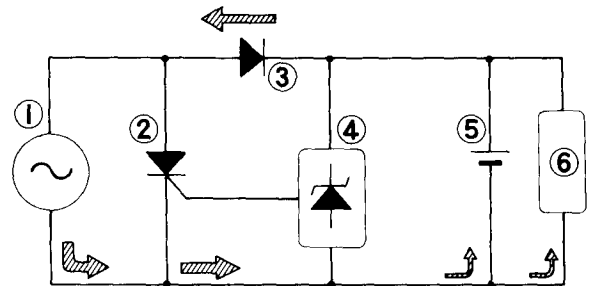

2. When battery voltage is high (Thyristor is on to provide bypass).

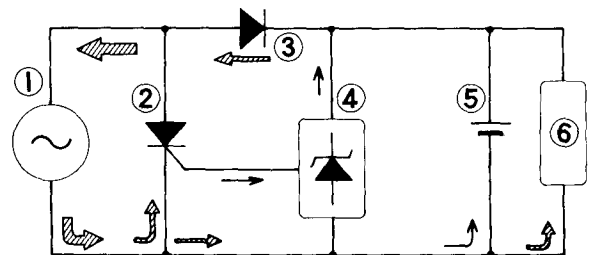

1. Alternator
2. Thyristor

4. Control Unit
5. Battery

Charging System Inspection

Initial inspection

When there are any problem indications in the charging system, give the system a quick initial inspection or check before starting a series of time consuming tests, or worse yet, removing parts for repair or replacement. Such a check will often turn up the source of the trouble.

Make sure all connectors in the circuit are clean and tight. Examine wires for signs of burning, fraying, etc. Poor wires and bad connections will affect electrical system operation. Check the regulator/rectifier and alternator for evidence of physical damage.

A worn out or badly sulphated battery will produce numerous problems that cannot be corrected until the battery is replaced. **ALWAYS CHECK BATTERY CONDITION BEFORE CONDEMNING OTHER PARTS OF THE SYSTEM. A FULLY CHARGED BATTERY IS A MUST FOR CONDUCTING ACCURATE SYSTEMS TESTS.**

Charging system malfunctions can be traced to either the battery, alternator, regulator/rectifier, or the wiring. Troubles may involve one unit or in some cases, all units. Never replace a defective unit without determining what **CAUSED** the failure. If the failure was brought on by some other unit or units, they too must be repaired or replaced, or the new replacement will soon fail.

Operational inspection of charging system

Before making this test, check the condition of the battery (Pg. 218). If the battery voltage is less than 12 volts, charge the battery. Before starting the charging voltage test warm up the engine to obtain actual alternator operating conditions.

- Unlock the seat and swing it open.
- Set the multimeter to the 20V DC range, and connect the meter (+) lead to the battery (+) terminal and the meter (-) lead to the battery (-) terminal.

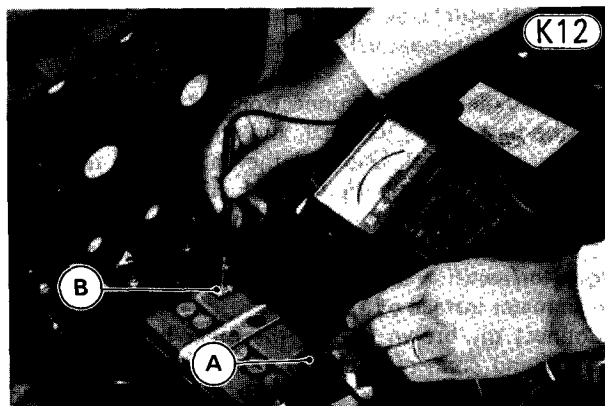

A. Battery (+) Terminal

B. Battery (-) Terminal

●Start the engine and run the engine at the rpm in Table

Table K2 Charging Voltage

Meter	Connections	Reading @4,000 rpm
20V DC	Meter (+) ↔ Battery (+) Meter (-) ↔ Battery (-)	about 14.5 V

- If the reading is much higher than the values specified in the table, the regulator/rectifier is defective or its leads are loose or open. If the reading does not rise as the engine speed increases, check the alternator and regulator/rectifier to determine which part is defective.

Alternator inspection

There are three types of alternator failures: short, open (wire burned out), or loss in rotor magnetism. A short or open in one of the coil wires will result in either a low output, or no output at all. A loss in rotor magnetism, which may be caused by dropping or hitting the rotor, by leaving it near an electromagnetic field, or just by aging, will result in low output.

- Remove the engine sprocket cover (Pg. 65), and disconnect the three yellow leads from the alternator.
- Connect the multimeter as shown in Table K3 to check the alternator output voltage of each pair of the three alternator output leads with no electrical loads.

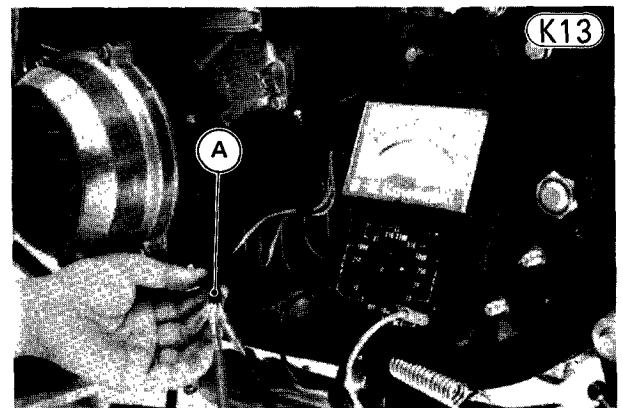

A. Alternator Output Leads

- Start the engine, run it at the rpm given in Table K3 and note the voltage reading.

If the output voltage shows the value in Table K3 the alternator operates properly and the regulator rectifier is damaged. A much lower reading than the given in the table indicates that the alternator is defective. Check the stator coil resistance as follows

- Stop the engine, set the multimeter to the x 1 Ω range and measure for continuity between each pair of the three alternator output leads. If there is more resistance than shown in Table K4, or no meter reading (infinity) for any two stator coil leads, the coil has an open lead and must be replaced. Much less than this resistance means the coil is shorted, and must

224 MAINTENANCE—ELECTRICAL

Table K3 Alternator Output Voltage

Meter Range	Connections	Reading @4,000 rpm
250V AC	One meter lead → One yellow lead	about 50V
	The other meter lead → Another yellow lead (Total of 3 measurements)	

Table K4 Stator Coil Resistance

Meter Range	Connections	Reading
x 1 Ω	One meter lead → One yellow lead	0.48 ~ 0.72 Ω
	The other meter lead → Another yellow lead (Total of 3 measurements)	

●Using the highest resistance range of the multimeter, measure the resistance between each of the yellow leads and chassis ground. Any meter reading less than infinity (∞) indicates a short, necessitating stator coil replacement.

If the stator coil windings have normal resistance, but the voltage check showed the alternator to be defective; then the rotor magnets have probably weakened, and the rotor must be replaced.

Regulator/rectifier inspection

Rectifier inspection:

●With the ignition switch turned off, pull off the left side cover, and remove the electrical panel.

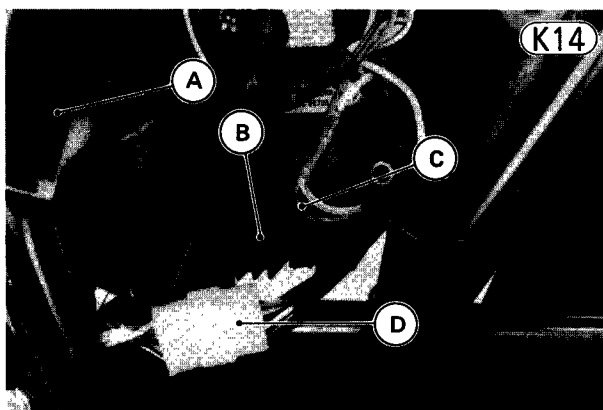

A. Electrical Panel **C. White/Red Lead**
B. Regulator/Rectifier **D. 6-Pin Connector**

●Disconnect the regulator/rectifier white/red lead and 6-pin connector.
●Using the x 10 or x 100 Ω range, check the resistance in both directions between the white/red lead and each yellow lead, and between the black lead and each yellow lead. There is a total of 12 measurements. The resistance should be low in one direction and more than ten times as much in the other direction. If any two leads are low or high in both directions, the

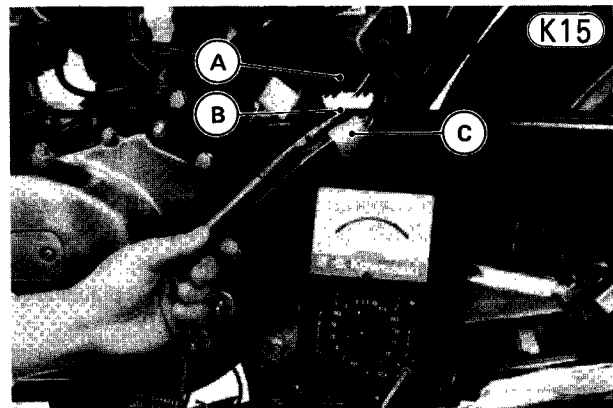

A. Regulator/Rectifier **C. 6-pin Connector**
B. White/Red Lead

NOTE: The actual meter reading varies with the meter used and the individual rectifier, but, generally speaking the lower reading should be within 1/3 scale of zero ohms.

Regulator test:

To test the regulator out of circuit, use three 12V batteries and a test light made from a 12V 3~6W bulb in a socket with leads.

●Remove the regulator/rectifier from the bottom of the battery case.
●Using auxiliary leads, connect one of the yellow leads to the battery (+) terminal, and connect the test light between the black lead and the battery (-) terminal. At this time the bulb should not be lit.

CAUTION The test light works as an indicator and also as a current limiter to protect the regulator/rectifier from excessive current. Do not use an ammeter instead of a test light.

●Connect the brown lead to the other battery (+) terminal and connect the black lead to the battery (-) terminal momentarily. At this time the bulb should not be lit.

●To apply 24V to the regulator/rectifier, connect two 12V batteries in series, and connect the brown lead to the battery (+) terminal and the black lead to the battery (-) terminal momentarily. The bulb should

CAUTION Do not apply more than 24 volts. If more than 24 volts is applied, the regulator/rectifier may be damaged. Do not apply 24 V more than a few seconds. If 24 volts is applied for more than a few seconds, the regulator/rectifier may be damaged.

- Repeat the above three steps for other two yellow leads.
- Replace the regulator/rectifier if the bulb does not light as described above.

NOTE: The above test is not foolproof. If the above checks show the regulator/rectifier is not damaged, but there is still trouble in the charging system, first carefully inspect the alternator, battery, wiring, and all connections. Replace the regulator/rectifier if all these other components turn out good.

Regulator Test

K16

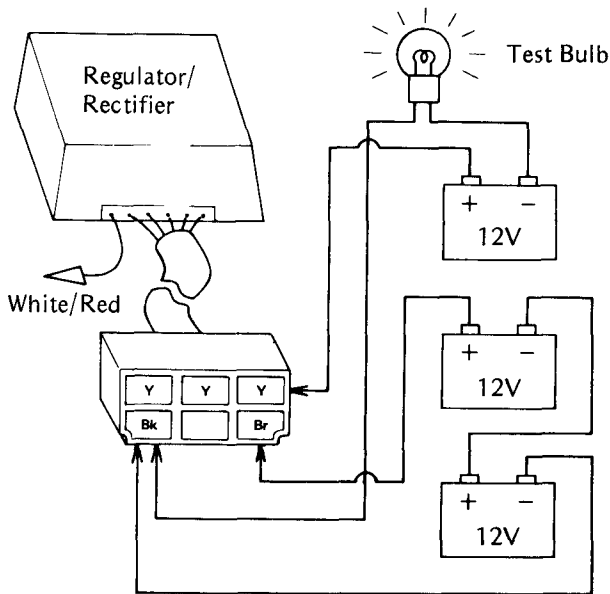

IGNITION SYSTEM

The ignition system for this model is essentially a battery and coil ignition system where the battery supplies the current for the primary circuit in the ignition system. However, this ignition system is transistorized and controls the current for the primary circuit by use of a solid-state electronic switching unit called a Darlington power transistor. The power transistors are triggered by pick-up coils and there are no mechanical breaker points, so the only periodic maintenance needed is automatic timing advancer lubrication (Pg. 10). Since contact breaker heel wear (with resultant retarded ignition timing) and breaker point pitting or burning are eliminated, periodic inspection and adjustment of the ignition timing are not required.

The working electrical part of the ignition system consists of a battery, two pick-up coils, an IC igniter, two ignition coils, and four spark plugs. To advance the ignition timing as engine rpm rises, an automatic centrifugal-type timing advancer is used. The ignition system comprises two parts; one part fires #1 and #4 cylinders, and the other part #2 and #3 cylinders. A schematic wiring diagram of one half the system is shown in Fig. K17. The other half is identical. Both work as follows.

Pick-up Coil

The pick-up coil assembly (a magnetic impulse generator) resembles the standard contact breaker assembly in most respects except that the two sets of breaker points have been eliminated. In their places is an iron timing rotor and two magnetic pick-up coils. Each pick-up coil assembly consists of a pair of permanent magnets and a pick-up coil on a mounting plate. The timing rotor which is attached to the timing advancer has one projection. As the projection on the timing rotor passes through the magnetic field created by the permanent

Ignition Circuit

K17

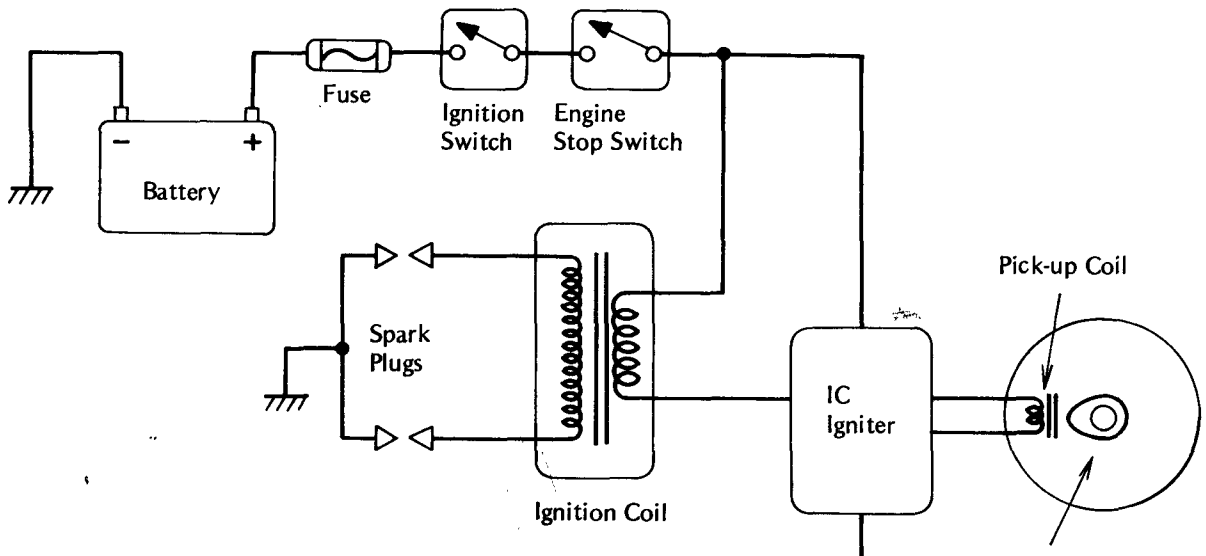

226 MAINTENANCE—ELECTRICAL

magnets on the mounting plate, a magnetic field alternately builds up and collapses. Each time the projection passes a pick-up coil core an electric current is developed. Each voltage pulse is conducted to the IC igniter where it is amplified and switches the Darlington power transistor on and off to control the primary current.

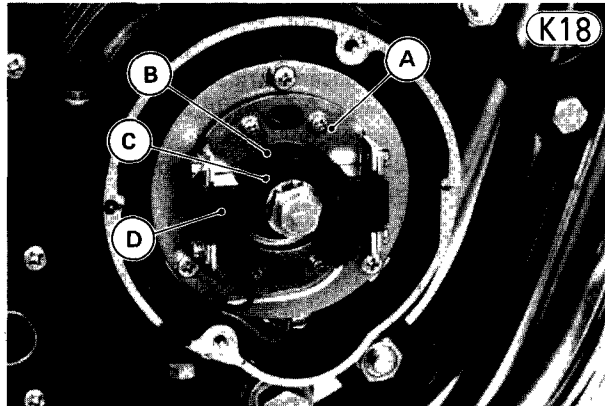

A. Permanent Magnet
B. Timing Advancer
C. Timing Rotor
D. Pick-up Coil

IC Igniter

The IC igniter utilizes the voltage pulse sent from the pick-up coil as follows to obtain stable induced high tension voltage from low to high engine speeds. The output voltage of the pick-up coil alternates as shown in Fig. K19.

Output Voltage of Pick-up Coil

(K19)

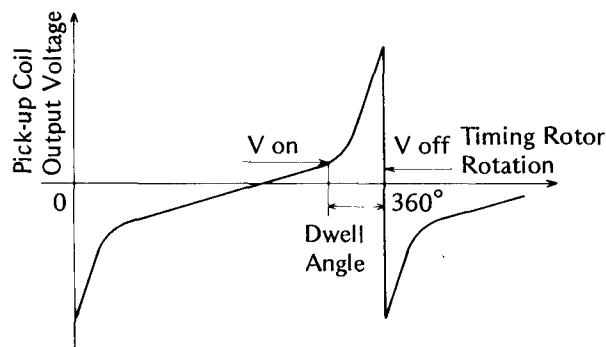

With rotation of the timing rotor the output voltage rises, and the power transistor conducts and permits primary current to flow when the pick-up coil output reaches the preset voltage (V_{on}). When the output voltage drops to the other preset voltage (V_{off}) after passing the voltage peak, the power transistor no longer conducts, stopping the current flow in the ignition coil primary winding and inducing a high tension voltage that jumps across the spark plug electrodes. In the case of a standard breaker point ignition system the dwell

primary circuit) decreases as the engine speed increases. This results in less current flow through the ignition coil primary winding and decreased induced voltage at high rpm. Conversely the dwell time in this transistorized ignition system is kept relatively constant by virtue of the pick-up coil output voltage. This is because the faster the engine runs, the higher the output voltage of the pick-up coil becomes and the sooner the V_{on} voltage is reached. Therefore the dwell angle increases to keep the dwell time long enough at high engine rpm so that the induced high voltage does not decrease.

Pick-up Coil Output Voltage at Low and High Speeds

(K20)

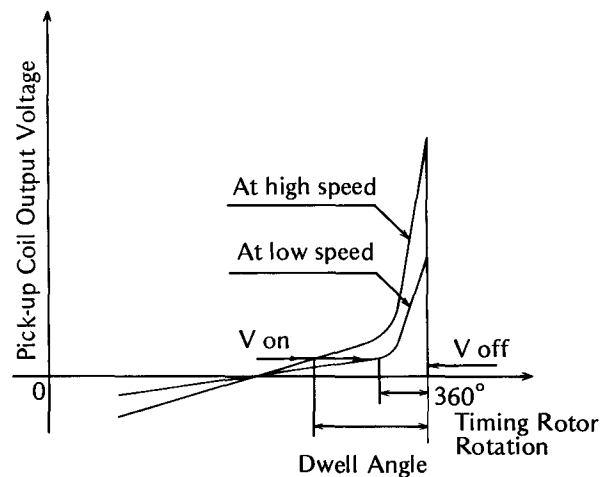

Dwell Time and Primary Current (Breaker Point System)

(K21)

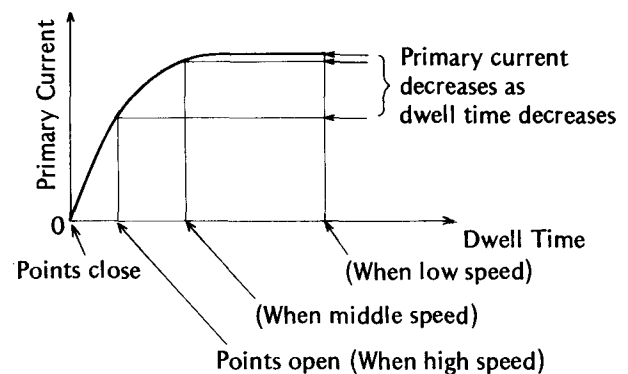

Ignition Coil

With the ignition switch on and the IC igniter on, current flows in the primary circuit, including the ignition coil primary winding where the magnetic field (which accompanies electron flow) is concentrated (due to the winding). When the IC igniter off, this circuit is broken stopping the electron flow and collapsing the magnetic field. As this field collapses, magnetic flux cuts through the secondary winding inducing a current in the winding. The voltage of this current, depending

the speed of the drop in the primary winding voltage, is much greater than the voltage in the primary winding. It is this high voltage that causes a spark to jump across the spark plug electrodes. A greater ratio of secondary winding turns over primary winding turns and a sharper drop of primary winding voltage increase the secondary winding voltage that is produced. For this reason, a certain ratio of turns in the ignition coil has been chosen and a certain voltage drop sharpness (determined by capacitor and breaker point performance) has been designed into the ignition system so that a spark of sufficient but not excessive strength will be produced.

Timing Advancer

The timing advancer is a device that advances the ignition timing (makes the spark plugs fire sooner) as engine speed rises. It consists of two weights and two springs connected to the timing cam that opens the contact breaker points. The more the engine speed rises, the further the weights are thrown out against spring tension, turning the rotor in the direction of crankshaft rotation and causing the points to open sooner.

If the mechanism is damaged, has a weak or broken spring(s), or does not move smoothly, the ignition timing will not advance smoothly or it may stick in one position. This will result in incorrect timing at certain engine speeds, causing poor engine performance. Failure to advance at all will cause poor high speed performance, and excessive advance will cause knocking and poor low speed performance.

Periodically wipe the advancer clean, apply oil to it, and fill the groove in the rotor with grease (Fig. K27).

Spark Plug

The spark plugs ignite the fuel/air mixture in the combustion chamber. To do this effectively and at the proper time, the correct spark plugs must be used, and the spark plugs must be kept clean and adjusted.

Tests have shown the NGK B8ES or ND W24ES-U, set to a 0.7~0.8 mm gap to be the best plug for general use.

If a plug of the wrong heat range is used, the electrodes may not hot enough to keep all the carbon burned off, but cool enough to keep from damaging the engine and the plug itself — about 400~800°C (750~1,450°F).

CAUTION The carbon on the electrodes conducts electricity, and can short the center electrode to ground by either coating the ceramic insulator or bridging across the gap. Such a short will prevent an effective spark. Carbon build-up on the plug can also cause other troubles. It can heat up red-hot and cause preignition and knocking, which may eventually burn a hole in the top of the piston. The heat range of the spark plug functions like a thermostat for the engine. Using the wrong type of spark plug can make the engine run too hot (resulting in engine damage) or too cold (with poor performance, misfiring, and stalling). The standard plug has been selected to match the normal usage of this motorcycle in combined street and highway

Spark Plug

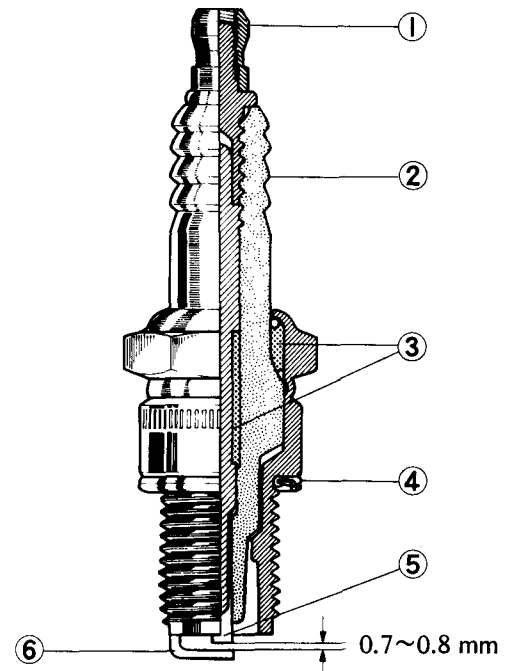

- 1. Terminal
- 2. Insulator
- 3. Cement
- 4. Gasket
- 5. Center Electrode
- 6. Side Electrode

Table K5 Spark Plug Specifications

Required Plug Threads	Riding Condition	Type
Diameter: 14.0 mm Pitch: 1.25 mm Reach: 19.0 mm	Normal	NGK B8ES, ND W24ES-U
		Ⓔ NGK BR8ES, ND W24ESR-U
	Cold weather [below 10°C (50°F)] low speed	NGK B7ES, ND W22ES-U
		Ⓔ NGK BR7ES ND W22ESR-U

Ⓔ : European and Canadian Model

Ignition system troubleshooting guide

If trouble is suspected in the ignition system, check the system by the following procedure.

An example of troubleshooting is shown in Fig. K23. To use this chart, follow the arrows on the chart selecting a “yes” or “no” arrow at each diamond-shaped step until you reach the “end”. Each test procedure is explained individually on the pages after the chart. This chart is for one half of the ignition circuit; use the

Ignition System Troubleshooting Guide

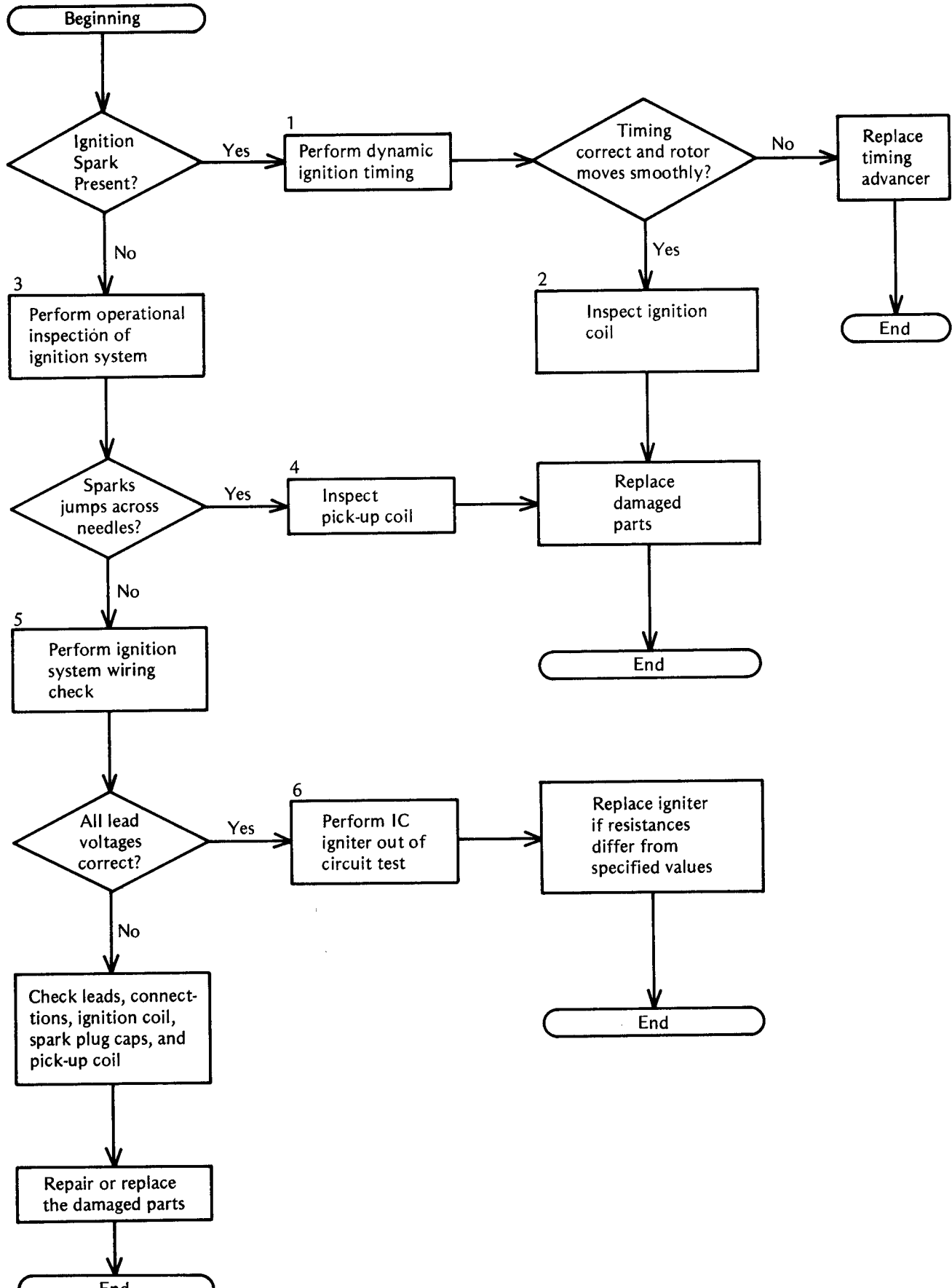

Description of Each Testing Procedure

1. Dynamic Ignition Timing Test

Check the ignition timing with a strobe light for both low and high speed operation. Timing advance begins at 1,900 ~ 2,100 rpm and reaches the maximum advance at 3,500 ~ 3,800 rpm. As a result, the timing must be checked at idle (below 1,900 rpm) and then at above 3,800 rpm when it is fully advanced.

Ignition Timing/Engine Speed Relationship

(K24)

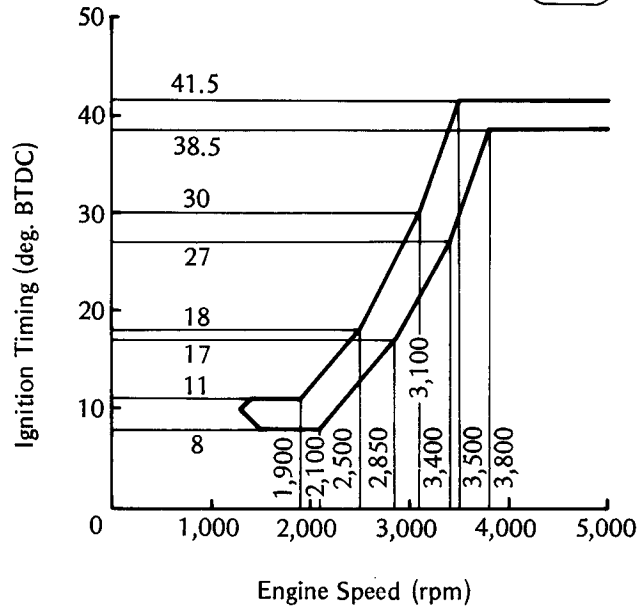

Check the timing as follows:

- Connect a strobe light to the #1 or #4 spark plug lead in the manner prescribed by the manufacturer in order to check the ignition timing under operating conditions.
- Turn on the ignition switch and engine stop switch. Start the engine, and direct the strobe light at the timing marks.
- Below 1,900 rpm, the "F" mark on the timing advancer must be aligned with the timing mark above the advancer for correct low rpm ignition timing.

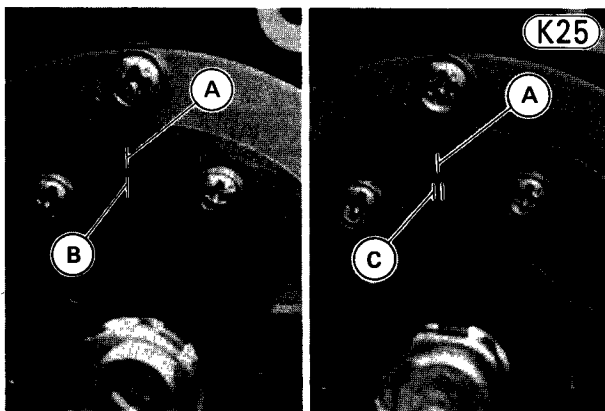

(K25)

A. Timing Mark

C. Advanced Mark

- Above 3,800 rpm, the advanced timing mark (the vertical lines to the right of the "4" mark) must be aligned with the timing mark above the advancer for correct high rpm ignition timing.

Table K6 Timing Advancing

	Engine Speed
Advance Begins	1,900 ~ 2,100 rpm
Full Advance	3,500 ~ 3,800 rpm

- If the timing is not correct, check that the rotor on the timing advancer turns smoothly on the shaft by hand and that no parts are visually damaged.

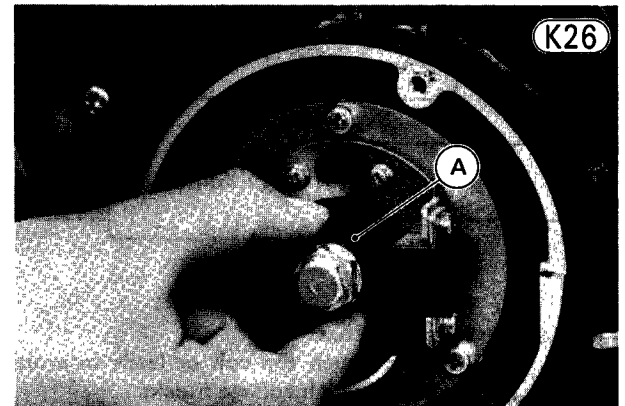

(K26)

A. Timing Rotor

- If the timing advancer binds on the shaft, lubricate it and re-check the ignition timing.

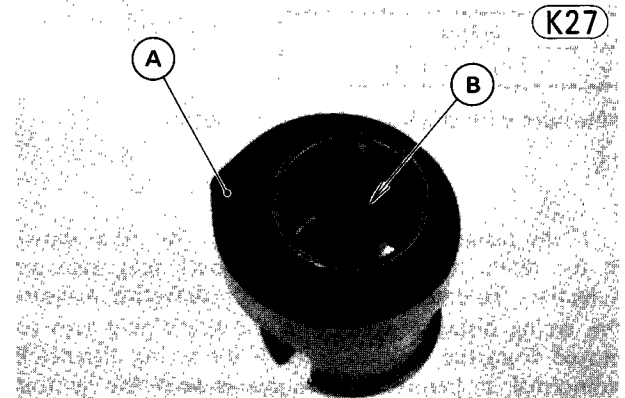

(K27)

A. Timing Rotor

B. Grease.

- A damaged timing advancer must be replaced with a new one. If advancer lubrication does not remedy

230 MAINTENANCE—ELECTRICAL

2. Ignition Coil Inspection

The most accurate test for determining the condition of the ignition coils is made by measuring arcing distance with the Kawasaki Electrotester (special tool: P/N 57001-980). Since a tester other than the Kawasaki Electrotester may produce a different arcing distance, the Kawasaki Electrotester is recommended for reliable results.

- Remove the ignition coil.
- Connect the ignition coil to the Kawasaki Electrotester as shown in the figure.

Ignition Coil Test

K28

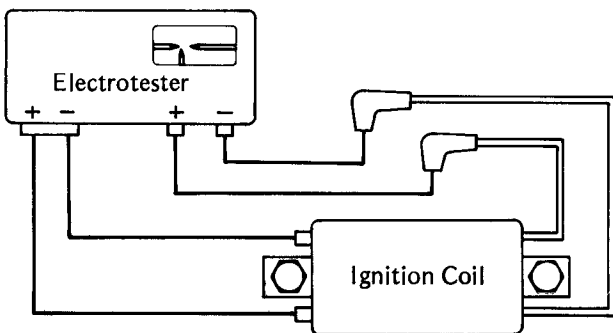

- Turn on the tester switches.

WARNING Do not touch the coil or leads to avoid extremely high voltage shocks.

- Gradually slide the arcing distance adjusting knob from left to right (small distance to large distance) carefully watching the arcing.
- Stop moving the knob at the point where the arcing begins to fluctuate, and note the knob position in mm. The reading should show the value in Table K7.

Table K7 Arcing Distance*

Standard
7 mm or more

*Measure with the Kawasaki Electrotester.

If the distance reading is less than the value shown in the table, the ignition coil or spark plug caps are defective. To determine which part is defective, measure the arcing distance again with the spark plug caps removed from the ignition coil. If the arcing distance is subnormal as before, the trouble is with the ignition coil itself. If the arcing distance is now normal, the trouble is with the spark plug caps.

If an Electrotester is not available, the coil can be checked for a broken or badly shorted winding with an ohmmeter. However, an ohmmeter cannot detect layer shorts and shorts resulting from insulation break-

To measure the primary winding resistance:

- Set the ohmmeter to the $\times 1 \Omega$ range, and measure for continuity between the primary lead terminals.

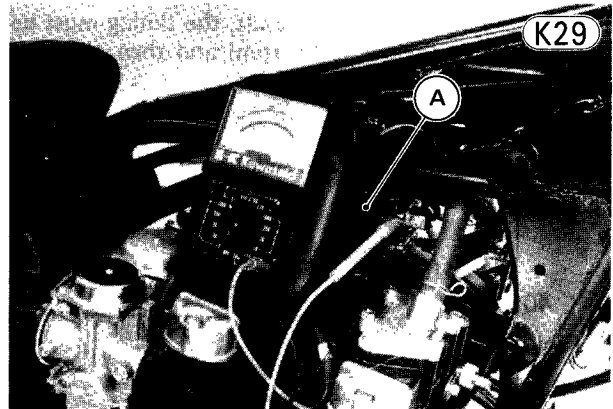

A. Ignition Coil

To measure the secondary winding resistance:

- Unscrew the spark plug caps from the spark plug leads.
- Set the ohmmeter to the $\times 1 \text{ k}\Omega$ range, and connect one ohmmeter lead to one of the spark plug leads and the other ohmmeter lead to the remaining spark plug lead.



Table K8 Ignition Coil Resistance

	Meter Range	Reading
Primary Winding	$\times 1 \Omega$	1.8 ~ 2.8 Ω
Secondary Winding	$\times 1 \text{ k}\Omega$	10 ~ 16 $\text{k}\Omega$

If the coil does not produce an adequate spark, or if either the primary or secondary winding does not have the correct resistance, replace the ignition coil.

With the highest ohmmeter range, check for continuity between each ignition coil pink lead, and one spark plug lead and the coil core (two tests on each coil). If there is any reading, the coil is shorted and must be replaced. Also, replace the ignition coil if

3. Operational Inspection of the Ignition System

- Have a DC voltage source of 6 ~ 12 volts output such as a motorcycle battery.
- Open the seat, and disconnect the 4-pin connector which connects the IC igniter and the pick-up coils.
- Remove the fuel tank, and pull the spark plug caps off the spark plugs.
- Connect the spark plug leads to the Electrotester in the same way as for measuring the arcing distance. For this test, the Electrotester need not be supplied with electric power (Fig. K32).
- Slide the adjusting knob to set the arcing distance to 5~8 mm.
- In the 4-pin connector from the IC igniter, connect the DC voltage source positive (+) lead to the black lead and the negative (-) lead to the blue lead for the #1 and #4 ignition coil (voltage source positive (+) lead to the yellow lead and the negative (-) lead to the red lead for the #2 and #3 ignition coil).
- Turn the ignition switch to the ON position, and switch the DC voltage source on and off.
- As the DC voltage source is switched, sparks should jump across the needles in the Electrotester.

4. Pick-up Coil Inspection

- Connect the multimeter to the pick-up coil leads to measure the coil resistance as shown in Table K9.

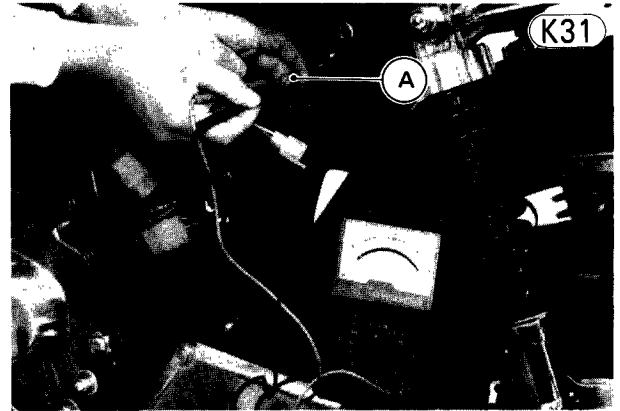

A. Pick-up Coil 4-pin Connector

- If there is more resistance than shown in the table, the coil has an open lead and must be replaced. Much less than this resistance means the coil is shorted, and must be replaced.
- Using the highest resistance range of the multimeter, measure the resistance between the pick-up coil leads and chassis ground. Any meter reading less than infinity (∞) indicates a short, necessitating replacement of the pick-up coil assembly.

Table K9 Pick-up Coil Resistance

Meter Range	Connections	Reading
x 100 Ω	One meter lead \rightarrow Black or Yellow Lead The other meter lead \rightarrow Blue or Red Lead	360 ~ 540 Ω

Operational Inspection of the Ignition System

K32

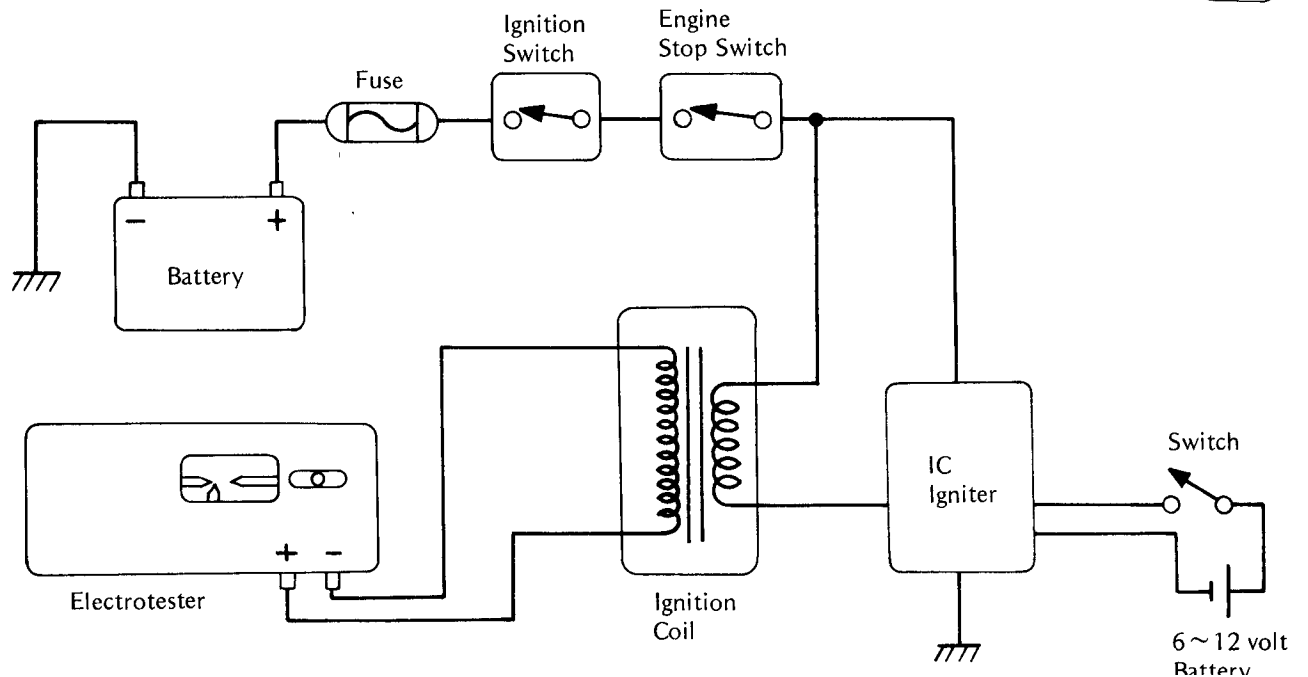

232 MAINTENANCE—ELECTRICAL

- Visually inspect the pick-up coil assembly. If the permanent magnets and coils are damaged, replace the pick-up coil assembly.

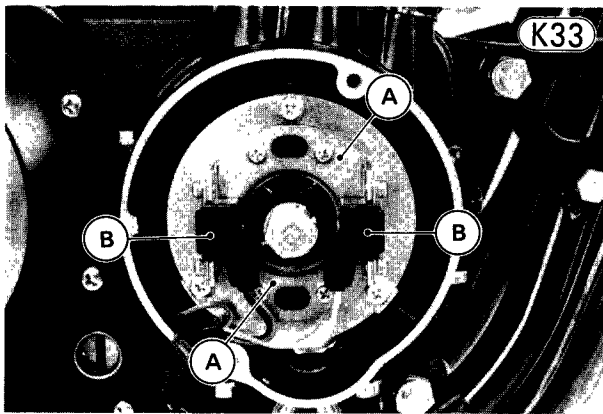

A. Magnet

B. Pick-up Coil

5. Ignition System Wiring Check

- Reconnect all leads and connectors which were disconnected.
- Connect the multimeter to the IC igniter leads as shown in Table K10, turn on the ignition switch, and note the meter readings. Measure the lead voltages with the engine stopped.

6. IC Igniter Out of Circuit Test

- Turn off the ignition switch, and disconnect all the IC igniter leads and connector.

Table K10 Wiring Inspection

Meter Range	Connections*	Location	Reading
20V DC	Meter (+) → Yellow/Red, Black, or Green	At the 4-pin connector for the ignition coils	Battery voltage
	Meter (+) → Black, Blue, Yellow, or Red	At the 4-pin connector for the pick-up coils	0.5~1.0 V

*Connect the meter (–) lead to ground.

Table K11 IC Igniter Resistance

Meter Range	Connections	Location	Reading*
x 1 k Ω	Meter (+) → Black/Yellow Meter (–) → Black, Green	At the 4-pin connector for the ignition coils	∞
x 100 Ω	Meter (+) → Black, Green Meter (–) → Black/Yellow	”	200 ~ 500 Ω
	Meter (+) → Yellow/Red Meter (–) → Black/Yellow	”	200 ~ 600 Ω
	Meter (+) → Black/Yellow Meter (–) → Yellow/Red	”	300 ~ 700 Ω
x 1 k Ω	Meter (+) → Blue (Red) Meter (–) → Black (Yellow)	At the 4-pin connector for the pick-up coils	25 ~ 45 k Ω
	Meter (+) → Black (Yellow) Meter (–) → Blue (Red)	”	20 ~ 40 k Ω

*Measured with the Kawasaki Hand Tester (57001-983)

A tester other than the Kawasaki Hand Tester may show slightly different readings.

- Connect the multimeter as shown in Table K11 to check the internal resistance of the igniter.

ELECTRIC STARTER SYSTEM

Starter Motor Circuit

The starter motor circuit includes the starter button (switch), starter lockout switch, starter relay, battery, and starter motor. The starter lockout switch mounted on the clutch lever holder is designed to prevent starter motor operation unless the clutch is disengaged. When the ignition switch is on, the clutch lever is pulled (the starter lockout switch is on), and the starter button is pushed, a small amount of current flows through the switches and the relay coil. This current magnetizes the relay core, which then pulls the armature to it, closing the relay contacts. The closed contacts complete a circuit for the starter motor, and the motor turns. The reason for using a relay instead of using the switch to turn on the starter motor directly is that the starter motor requires much current – enough that relatively thick wire is necessary to carry the current to the starter motor. Because it is not practical to put a heavy switch on the handlebar and have large wires running to it, the starter switch is made to carry just the light relay coil current, and heavy contacts inside the relay carry the starter motor current.

CAUTION Because of the large amount of current, never keep the starter button pushed any time that the starter motor will not turn over, or the current may burn out the starter motor windings.

Starter Motor Circuit

(K34)

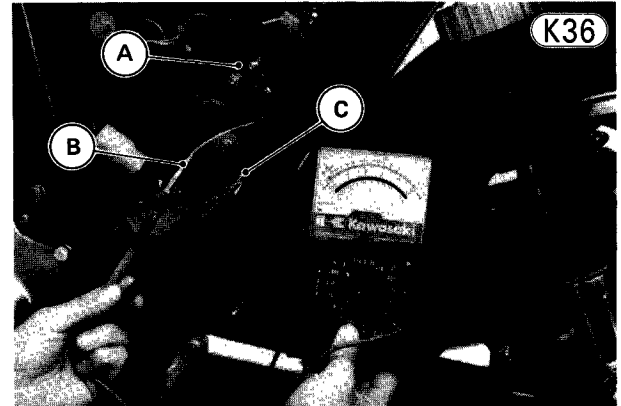
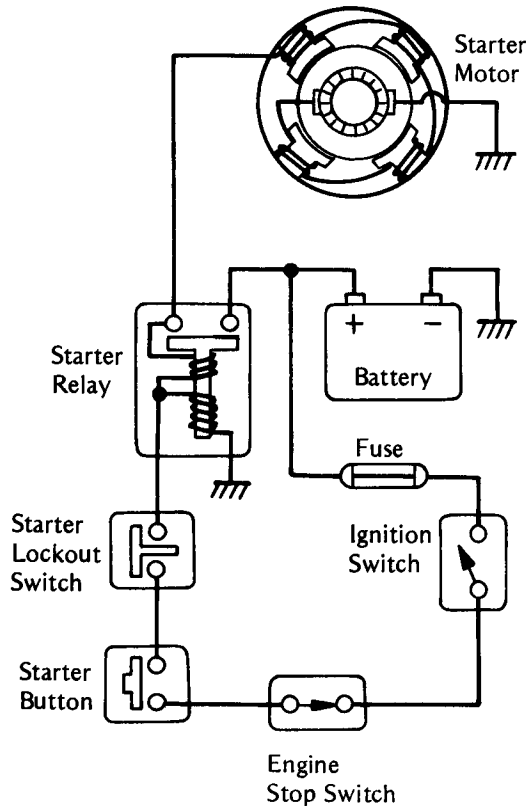

(K36)

A. Starter Relay
B. Yellow/Red Lead
C. Black Lead

However, if there is about zero ohms resistance, the relay may be good; check that there is actually voltage to the relay before deciding that the relay is defective. To check for the voltage, first turn the meter to 20V DC, connect the (-) meter lead to the yellow/red lead which was disconnected from the relay lead, and connect the (+) meter lead to the black lead. Pulling the clutch lever, push the starter button, and see if the meter reads battery voltage. If the meter does not, there is wiring, starter lockout switch, or starter switch trouble. If the meter reads battery voltage but the relay does not click, the relay is defective.

Starter relay test

Disconnect the starter motor lead from the starter relay in the electrical cover, and connect an ohmmeter set to the x 1 Ω range across the relay terminals. Pulling the clutch lever, push the starter button, and see if the meter reads zero ohms. If the relay makes a single clicking sound and the meter reads zero, the relay is good. If the relay clicks but the meter does not read zero, the relay is defective and must be replaced.



(K35)

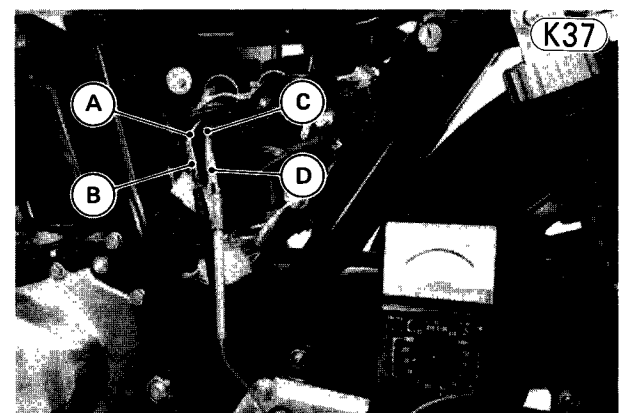

(K37)

A. Yellow/Red Lead
B. Meter (-) Lead
C. Black Lead
D. Meter (+) Lead

Starter lockout switch test

Remove the fuel tank (Pg. 43), and disconnect the two starter lockout switch black leads. Connect an ohmmeter set to the x 1 Ω range across the two black leads. Pull the clutch lever, and see if the meter reads zero ohms. If the meter does not, the starter lockout

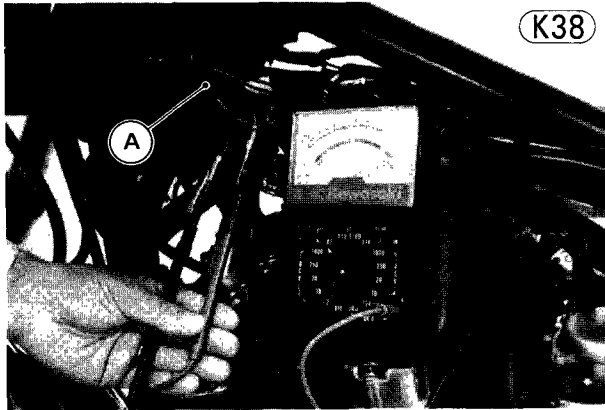

K38

A. Switch Leads

Starter button test

Remove the fuel tank (Pg. 43), and disconnect the 4-pin connector and black lead from the right switch housing. Connect an ohmmeter set to the $\times 1\Omega$ range across the yellow and the black leads. Push the starter button, and see if the meter reads zero ohms. If the meter does not, the starter button is defective and the entire right switch housing assembly must be replaced.



K39

A. 4-pin Connector

B. Black Lead

Starter Motor

The starter motor is installed with an idle gear to transmit starter motor rotation to the crankshaft. A starter clutch (Pg. 236) disengages the starter motor once the engine starts.

Fig. K42 shows starter motor construction. The field coils ⑭ are wound around four cores, forming the yoke ⑪, and the armature windings ⑫ are connected to the commutator ⑬ and receive their current through the brushes ⑯. If the brushes are not making good contact, no starter motor current will flow since the field coils and armature windings are connected in series, and the motor will not turn over. A short or open in a coil or winding may also cause the motor to be inoperative. Particles from brush wear may be another

into the bearing at the rear of the motor, causing hear seizure.

A planetary gear train is provided at the output side of the starter motor. The planetary gear train consists of an internal gear ⑦, two planet pinions ⑧, and a sun gear ⑩. These gears reduce the rotational speed of the armature to give more power to the output shaft. The internal gear is fixed to the end cover.

Carbon brushes

Worn brushes or weak springs will cause poor brush contact.

Measure the length of the brushes, and replace both if either one is worn down to less than the service limit.

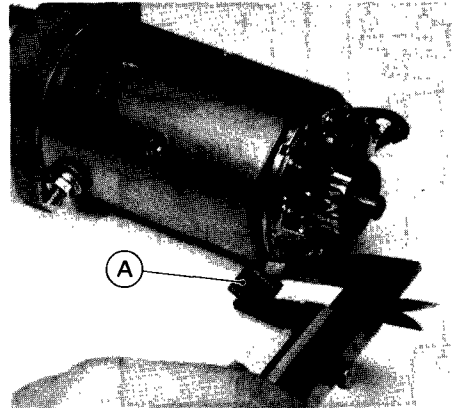

K40

A. Carbon Brush

Table K12 Carbon Brush Length

Service Limit	6 mm
---------------	------

Brush spring

Spring tension should be 560~680 grams but a spring can be considered serviceable if it will snap the brush firmly into place.

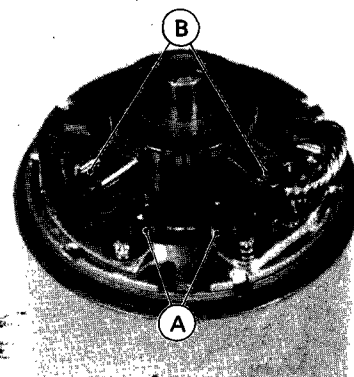

K41

Starter Motor Construction

K42

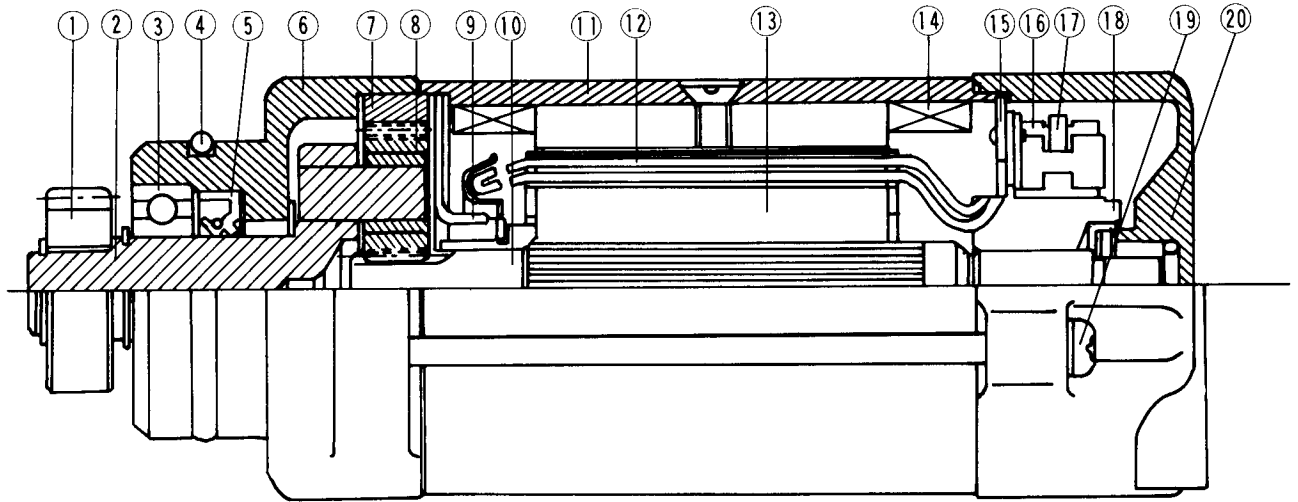

- | | | | |
|-------------------------|------------------|----------------------|------------------|
| 1. Starter Motor Pinion | 6. End Cover | 11. Yoke Assembly | 16. Carbon Brush |
| 2. Output Shaft | 7. Internal Gear | 12. Armature Winding | 17. Spring |
| 3. Ball Bearing | 8. Planet Pinion | 13. Armature | 18. Commutator |
| 4. O Ring | 9. End Plate | 14. Field Coil | 19. Screw |
| 5. Grease Seal | 10. Sun Gear | 15. Brush Plate | 20. End Cover |

Commutator

A dirty or damaged commutator will result in poor brush contact and cause the brushes to wear down quickly. In addition, particles from brush wear accumulating between commutator segments may cause partial shorts.

Smooth the commutator surface if necessary with fine emery cloth, and clean out the grooves as illustrated. Determine as accurately as possible the depth of the grooves between commutator segments. Replace the armature with a new one if the groove depth is less than the service limit.

Commutator Groove

K44

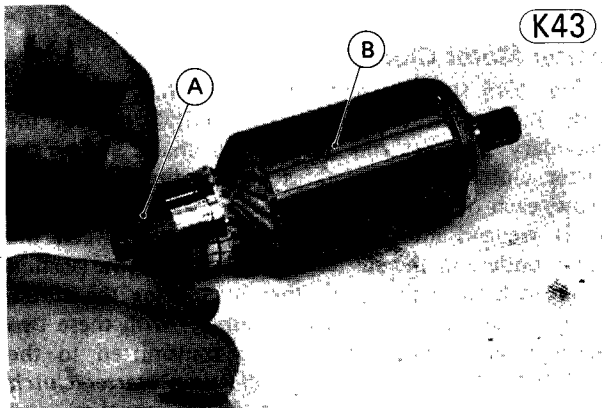
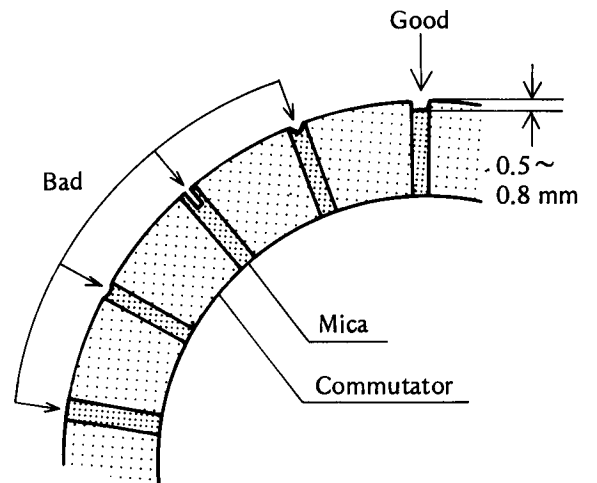

K43

Table K13 Commutator Groove Depth

Service Limit	0.2 mm
---------------	--------

Using the $\times 1 \Omega$ ohmmeter range, measure the resistance between any two commutator segments. If

236 MAINTENANCE—ELECTRICAL

segments, a winding is open and the armature must be replaced.

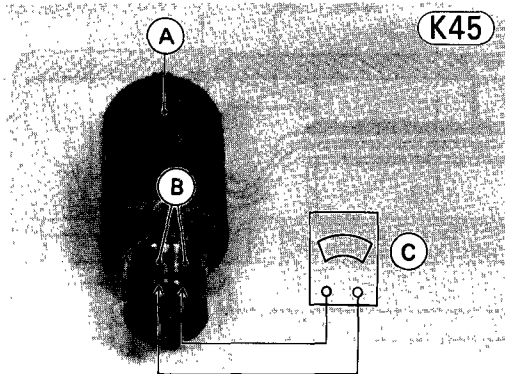

A. Armature
B. Commutator Segments
C. Ohmmeter (x 1 Ω)

Using the highest ohmmeter range, measure the resistance between the commutator and the shaft. If there is any reading at all, the armature has a short and must be replaced.

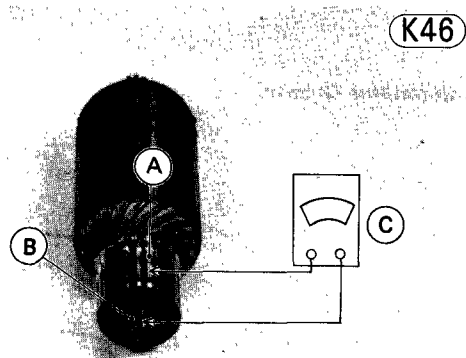

A. Commutator
B. Shaft
C. Ohmmeter (x 1 k Ω)

Even if the foregoing checks shows the armature to be good, it may be defective in some manner not readily detectable with an ohmmeter. If all other starter motor and starter motor circuit components check good, but the starter motor still does not turn over or only turns over weakly, replace the armature with a new one.

Field coils

Using the x 1 Ω ohmmeter range, measure the resistance between the (+) side carbon brush and the starter motor terminal. If there is not close to zero ohms, the field coils have an open and the yoke assembly must

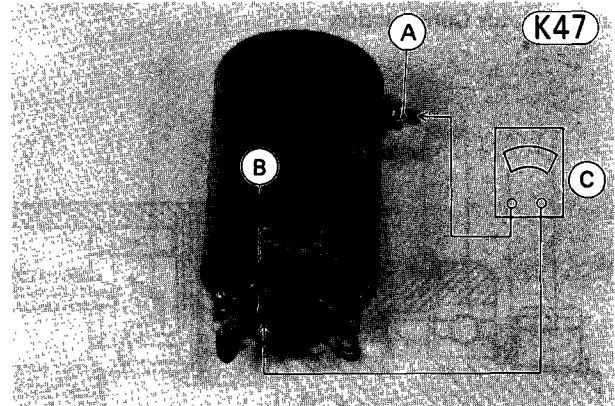

A. Terminal
B. (+) Side Carbon Brush
C. Ohmmeter (x 1 Ω)

Using the highest ohmmeter range, measure the resistance between the (+) side carbon brush and the yoke (housing). If there is any meter reading, the coils are shorted to ground and the yoke assembly must be replaced.

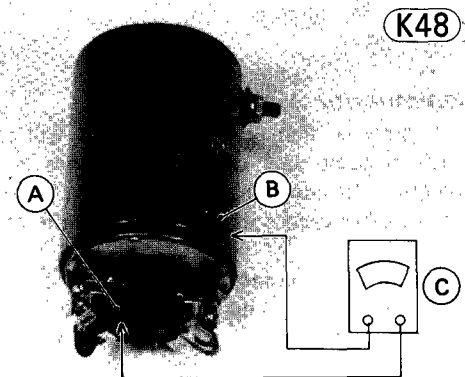

A. (+) Side Carbon Brush
B. Yoke
C. Ohmmeter (x 1 k Ω)

Starter Motor Clutch

Fig. K49 shows starter motor clutch. The clutch body ① is connected to the crankshaft ③ through the secondary sprocket and the primary chain. When the starter clutch gear ② rotates in the direction of the arrow, each of the three rollers ④, pushed by its spring ⑥, is wedged into the narrower space between the clutch body and the starter clutch gear hub (the portion jutting out from the gear), thereby locking the clutch body and starter clutch gear together. With these two locked, starter motor rotation is transmitted to the crankshaft through the starter idle gear, starter clutch gear, rollers, clutch body, secondary sprocket, and

Starter Motor Clutch Operation

(K49)

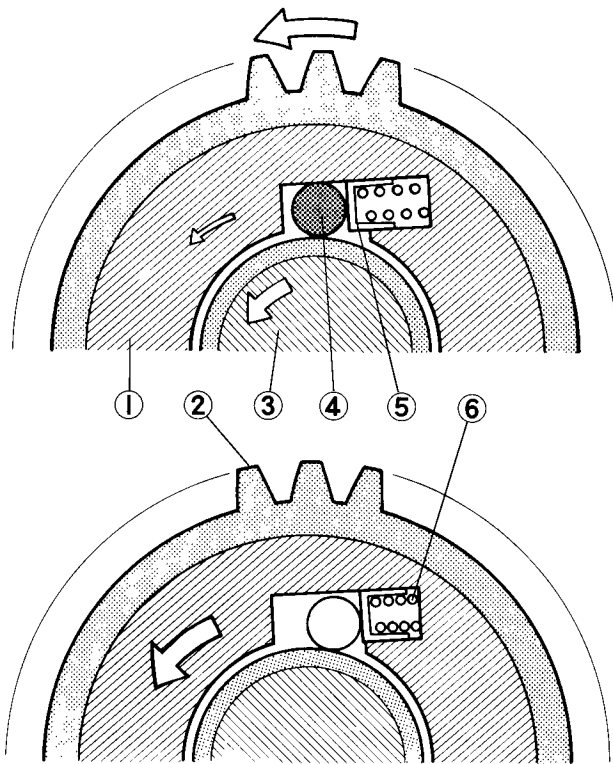

- | | |
|----------------|---------------|
| 1. Clutch Body | 4. Roller |
| 2. Clutch Gear | 5. Spring Cap |
| 3. Crankshaft | 6. Spring |

When the engine starts, friction with the starter clutch gear (and at higher speeds, inertia) moves the rollers back against the tension of their springs so that they no longer serve as wedges locking the clutch body and starter clutch gear together. In this manner, the engine rotates freely without forcing the starter motor to turn with it.

If the rollers or the starter clutch gear hub becomes damaged or worn, the rollers may lock in place so that the starter motor will not disengage when the engine starts. On the other hand, roller or sprocket hub damage could prevent the clutch from engaging properly, causing the starter motor to run freely without transmitting rotation.

Clutch inspection

Remove the starter motor (Pg. 69), and turn the starter motor idle gear by hand. When viewed from the left side of the engine, the starter motor idle gear should turn counterclockwise freely, but should not turn clockwise. If the clutch does not operate as it should or if it makes noise, disassemble the starter clutch (Pg. 78), examine each part visually, and replace

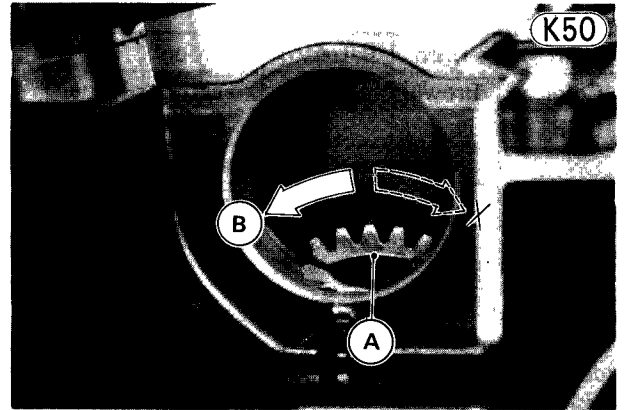

A. Starter Motor Idle Gear

B. Turn freely.

IGNITION SWITCH

The ignition switch has four positions: off, on, lock, and park. In the off and lock position all circuits are turned off and the key can be removed from the switch. In the on position the motorcycle can be started and all electrical equipment can be used. The key cannot be removed from the switch when it is in the on position. In the park position the tail light is on, but all other circuits are cut off and the key can be removed from the switch. This provides added visibility when the motorcycle is parked.

Testing the switch

Table K14 shows the internal connections of the ignition switch for each switch position. To check the switch, remove the headlight unit (Pg. 129), and disconnect the 6-pin connector and brown lead from the switch. Then use an ohmmeter to verify that all the connections listed in the table are making contact (zero ohms between those wires), and that no other wires are connected. If there are any opens or shorts in the switch, replace it with a new one.

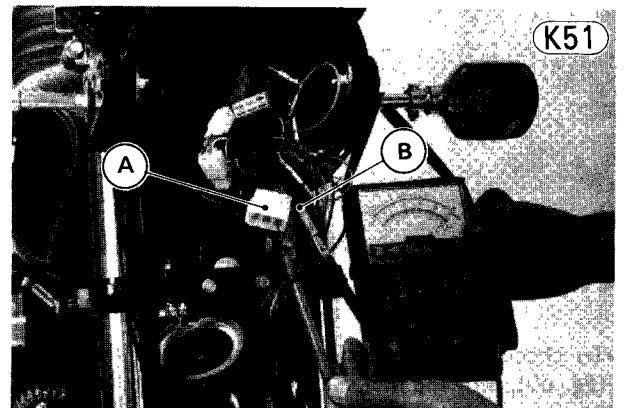

(K51)

Table K14 Ignition Switch Connections

Lead	Horn	Battery 1	Ignition	Tail 1	Tail 2	Battery 2	Tail 3
Color	Brown	White	Yellow	Blue	Red	White	Orange/Green
OFF							
ON	●————●————●			●————●		●————●	
P(Park)		●————●————●			●————●		

NEUTRAL SWITCH

A neutral indicator light is provided so that the rider can readily determine whether or not the transmission is in neutral. The neutral switch, installed in the external shift mechanism cover, consists of a spring loaded pin which contacts the outer surface of the shift drum pin plate when the transmission is in neutral. This completes the neutral indicator light circuit, which turns on the neutral indicator light.

Switch inspection

- Turn on the ignition switch. Watching the indicator light, shift the transmission into neutral and then shift the transmission into other positions. If the neutral indicator light goes on in neutral position and the light does not go on in other positions, the neutral switch is good.
- If the neutral indicator light does not go on in the neutral position or if it does go on in other positions, remove the engine sprocket cover (Pg. 65), and disconnect the neutral switch light lead.
- To check for the voltage, first turn the meter to 20V DC, connect the (+) meter lead to the switch lead, and connect the (-) meter lead to chassis ground.
- Turn the ignition switch on, and see if the meter reads battery voltage. If the meter does not indicate battery voltage, the trouble is either defective wiring or a burned-out indicator bulb. If the voltmeter reads battery voltage, then the neutral switch may be defective.

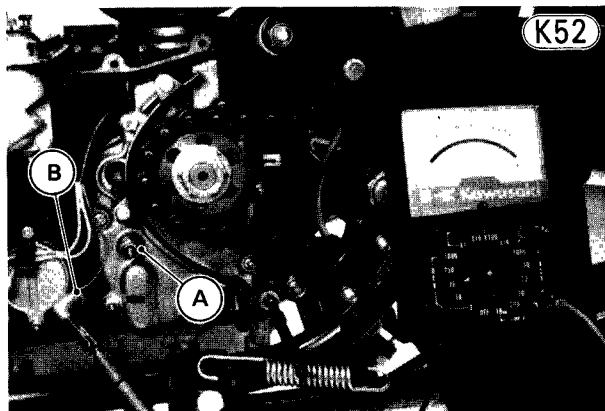

A. Neutral Switch B. Switch Lead

- To check the neutral switch, first remove the switch (Pg. 69), turn the meter to the x 1 Ω range, and measure the resistance between the switch terminal and the

zero ohms, the switch is defective, and must be replaced.

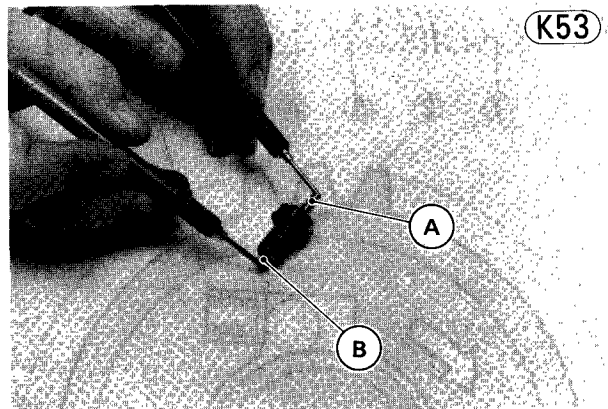

A. Switch Terminal B. Spring Loaded Pin

- If the resistance is close to zero ohms, measure the resistance between the switch terminal or spring loaded pin and the switch body. If there is any meter reading, the neutral switch is defective and must be replaced.

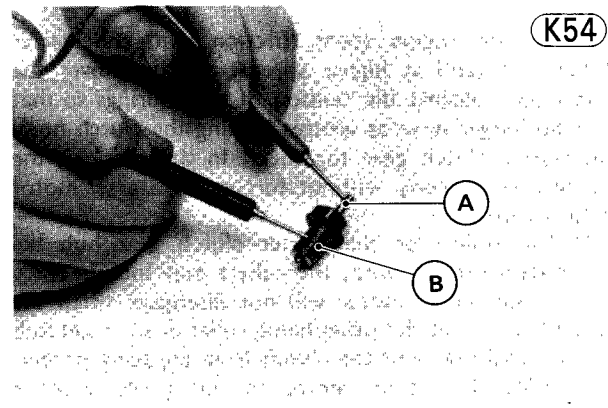

A. Switch Terminal B. Switch Body

LIGHTING SYSTEM

Headlight Circuit and Reserve Lighting System

Fig. K55 through K58 are KZ750-E and KZ750-H

Headlight Circuit for KZ750-E (US and Canadian models)

K55

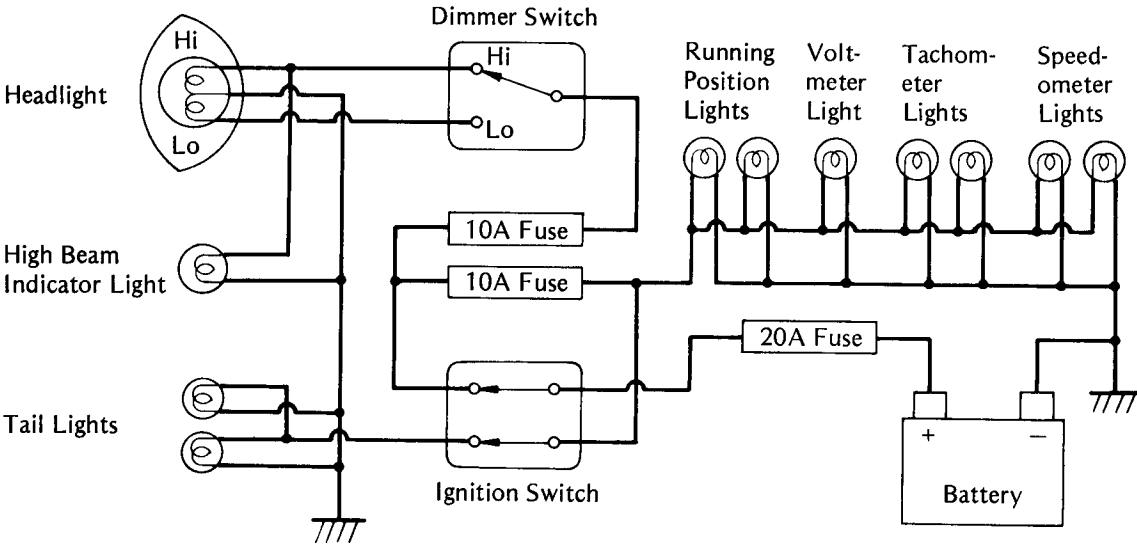

Headlight Circuit for KZ750-E (Other than US and Canadian models)

K56

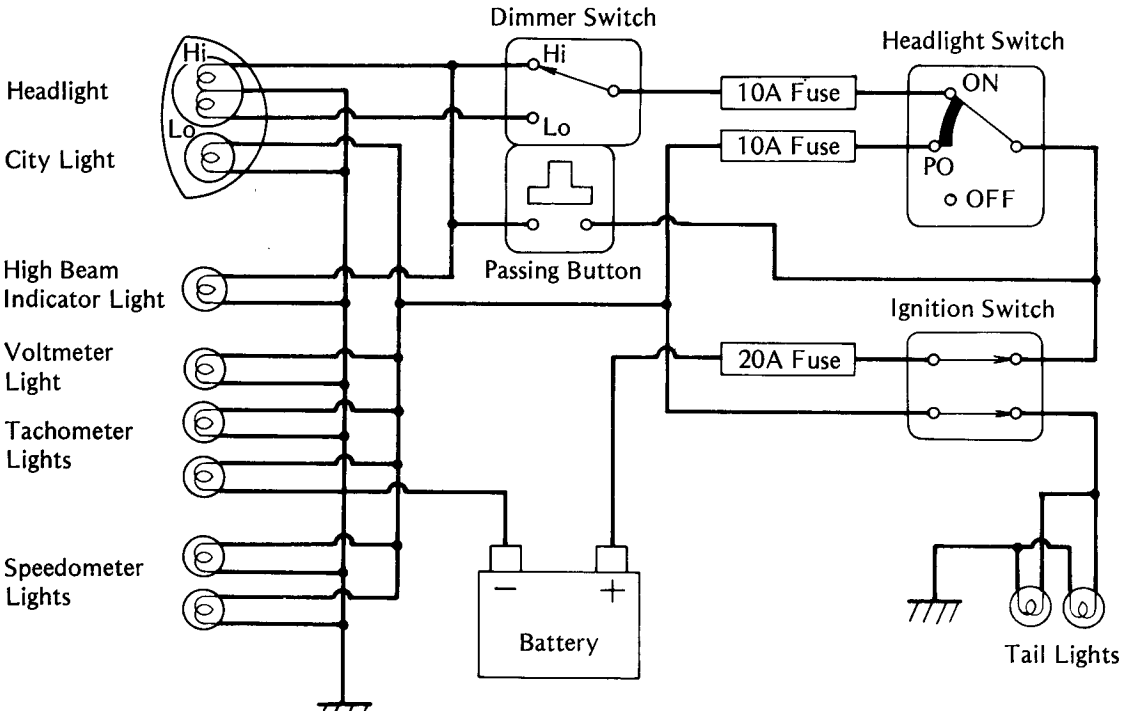

240 MAINTENANCE—ELECTRICAL

Headlight Circuit for KZ750-H (US and Canadian models)

(K57)

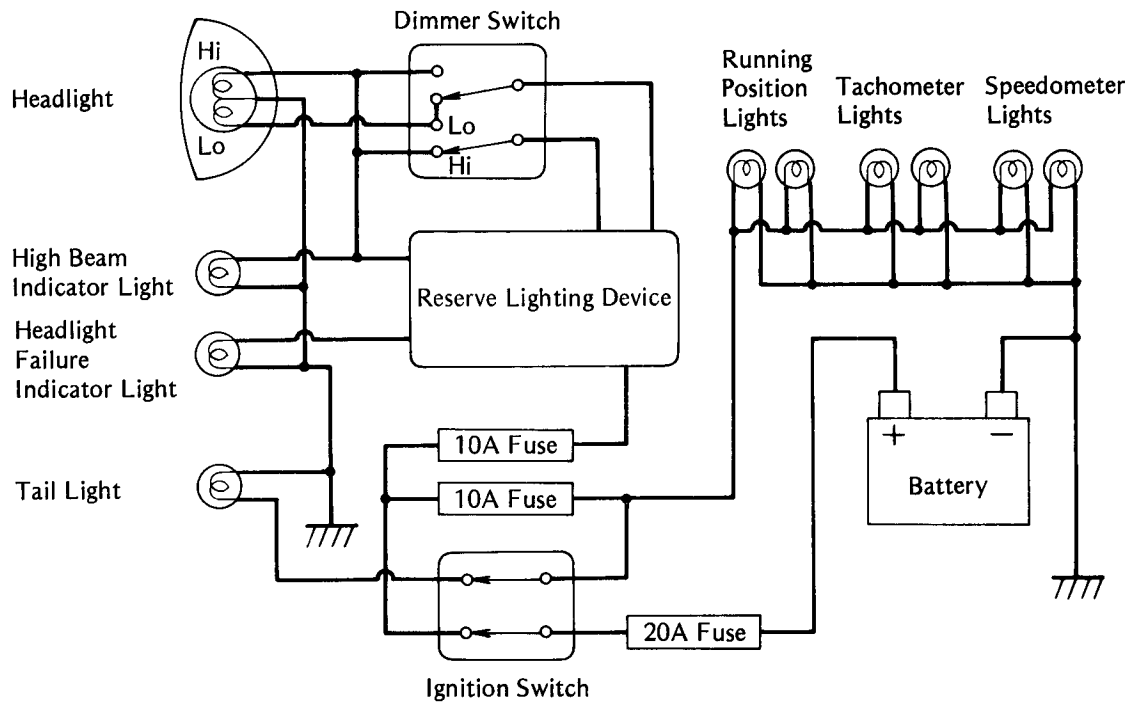

Headlight Circuit for KZ750-H (Other than US and Canadian models)

(K58)

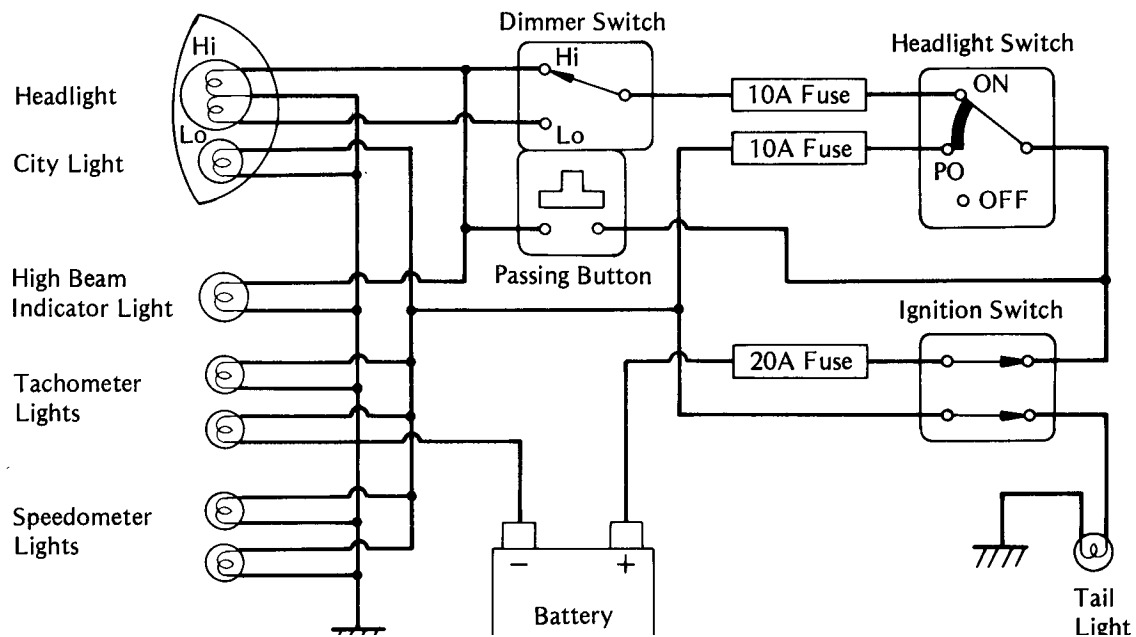

The models of KZ750-H for US and Canada contain a reserve lighting system in the headlight circuit. This system is a safety device that keeps the headlight on if one of the filaments burns out.

If either the high or low beam burns out, the reserve lighting system switches over to the remaining filament automatically, and lights the white headlight failure indicator light to show that the headlight bulb must be replaced. If the high beam filament burns out, the low beam is automatically turned on; if low beam burns out, the high beam is turned on but more dimly than normal.

NOTE: Current is always flowing slightly in the headlight failure indicator light when the main switch and ignition switch are "ON" position. So you may notice the indicator light glimmers unless the headlight filaments burn out.

In the US and Canadian model, there is no headlight switch, and when the ignition switch is turned on, the headlight circuit is completed, turning on the headlight, tail light(s), running position lights, and meter lights.

In the model other than US and Canadian, the center city light position of the headlight switch turns on the small city light, tail light and meter lights for driving in the city after dark. When the switch is turned to the on position, the headlight comes on and city light stays on. High and low beam can be selected only when the headlight switch is in the on position.

There is also a passing and horn button (Other than US and Canadian models). This button is spring loaded and when the button is pushed to pass, the high beam light (but not the tail light) comes on as a passing signal to the driver of the vehicle ahead. The passing button will light the high beam light regardless of the headlight switch position, and the button will spring back and turn the light off as soon as it is released.

Checking the reserve lighting system

- Remove the headlight unit.
- Disconnect the headlight socket and connect the three terminals of headlight bulb with corresponding leads using three suitable insulated wires.

Check of Reserve Lighting System

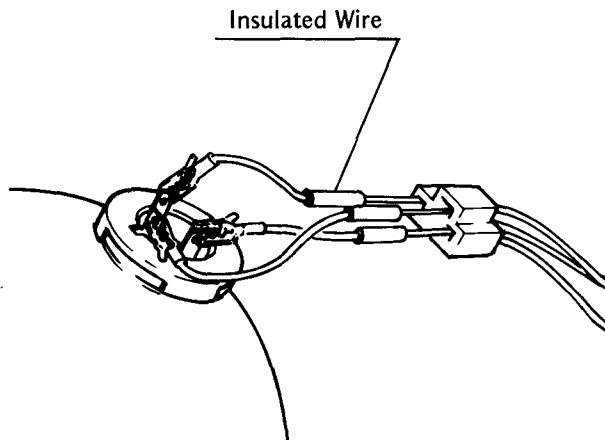

- Turn on the headlight and set the dimmer switch to the low beam position.
- Disconnect the wire which is connected to the red yellow lead to simulate a bad low beam filament. At this time the high beam should go on more dimly than normal, and the white headlight failure indicator should come on.
- Connect the red/yellow leads, and set the dimmer switch to the high beam position.
- Disconnect the wire which is connected to the red black leads to simulate high beam failure. At this time the low beam should come on and the white indicator light should light.

Headlight, dimmer switch inspection

Table K15 through K18 show the connections in the headlight switch, the connections in the dimmer switch for both high and low beam, and connections in the horn/passing switch.

- Remove the fuel tank, and disconnect the leads to the left or right switch housing.



- Use an ohmmeter to see that only the connection shown in the tables have continuity (zero ohms). If the switch has open or a short, it can be disassembled for repair. The contact surfaces may be cleaned, but no internal parts are available for replacement. If any parts are not repairable, the switch must be replaced as a unit.

Table K15 Headlight Switch Connections (Other than US and Canadian models)

	Brown/White	Brown	Bl/W
OFF			
• (City Light)	●————●		
ON	●————●	●————●	●————●

Table K16 Dimmer Switch Connections (for Reserve Lighting model)

	Red/Black	Blue/Yellow	Red/Yellow	Blue
Hi	●————●		●————●	
Lo	●————●			

242 MAINTENANCE—ELECTRICAL

**Table K17 Dimmer Switch Connections
(Other than Reserve Lighting model)**

	Red/Black	Blue	Red/Yellow
Hi	●————●		
Lo		●————●	

**Table K18 Horn/Passing Switch Connections
(Other than US and Canadian models)**

Color	Bk/W	////	R/Bk	Brown
OFF				
ON	●————●		●————●	
Switch	Horn		Passing	

If the headlight lights but does not light brightly, the trouble may be that the headlight is of improper wattage or the battery or the alternator is not supplying sufficient current. However, the trouble may also be caused by a short or a component drawing too much current in some other part of the electrical system.

Reserve lighting wiring inspection

- Unlock the seat, swing it open, and then pull out the 6-pin connector of the reserve lighting device.

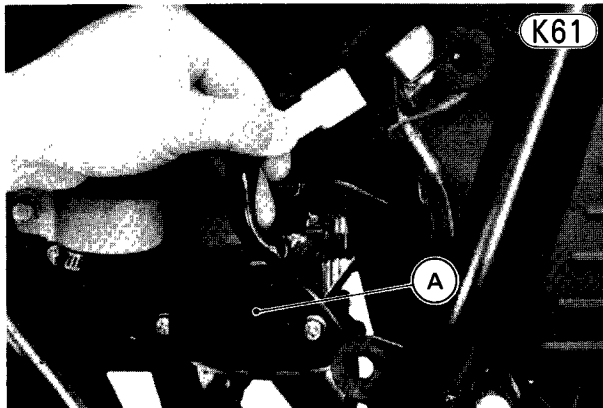

A. Reserve Lighting Device

- Turn on the ignition switch to “ON” position.
 - Check the voltage of each lead through the 6-pin connector by referring to the following procedure.
- NOTE:** Set a voltmeter to 20V DC range, and always ground the (–) probe of the voltmeter.

Trouble (a): When one filament is burned out, the other other is not turned on.

- Examine the voltage of blue/orange lead by applying the (+) probe of voltmeter to the lead. When the meter reading is about 12 V, both filaments of the headlight are burned out or the black/yellow lead is broken. When the meter reading is less than about 12 V, advance to the next step
- Examine the voltage of the blue lead. If the meter

defective. When the reading is 0 V, the ignition switch or wiring harness is broken.

Trouble (b): Both filaments for upper beam and lower beam are turned on at the same time.

- Examine the voltage of the blue/orange lead. When the meter reading is about 12 V, the reserve lighting device is defective. When the reading is 0 V, the dimmer switch is defective.

Trouble (c): The high beam is not dimmed when the low beam burns out and the high one is turned on automatically.

- Examine the voltage of the red/black lead. If the meter reading is about 12 V, the reserve lighting device is defective. If the reading is 0 V, the wiring harness is broken.

Trouble (d): The failure indicator light is not turned on when the headlight filament burns out.

- Examine the voltage of the light green/red lead. When the meter reading is about 12 V, the indicator light burns out or is not grounded. When the reading is 0 V, the reserve lighting device is defective.

Tail/Brake Light Circuit

The tail/brake light circuit is shown in Fig. K62 and K63. When the ignition switch is turned on, the brake light goes on whenever the circuit is closed by either the front or rear brake light switch.

When the ignition switch is turned to “Park” position, the tail lights go on. For the US and Canadian model, the tail lights to on also when the ignition switch is turned on. For the European model, they go on when the ignition switch and headlight switch are turned on.

The same bulbs are used for both the brake and tail lights.

Tail/Brake Light Circuit (for K2750-E)

K62

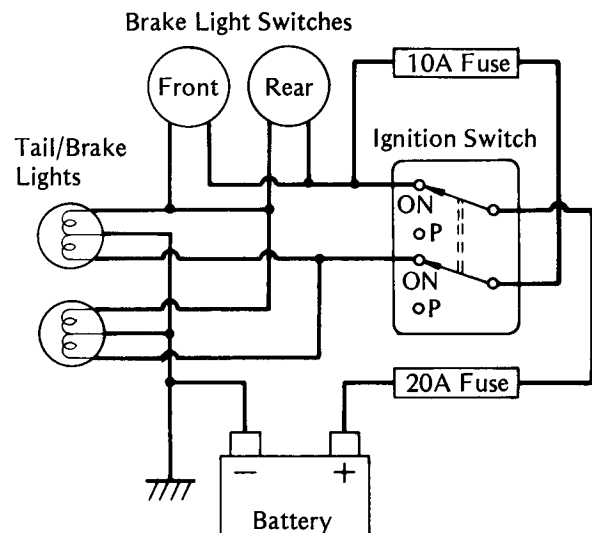

Tail/Brake Light Circuit (for KZ750-H)

K63

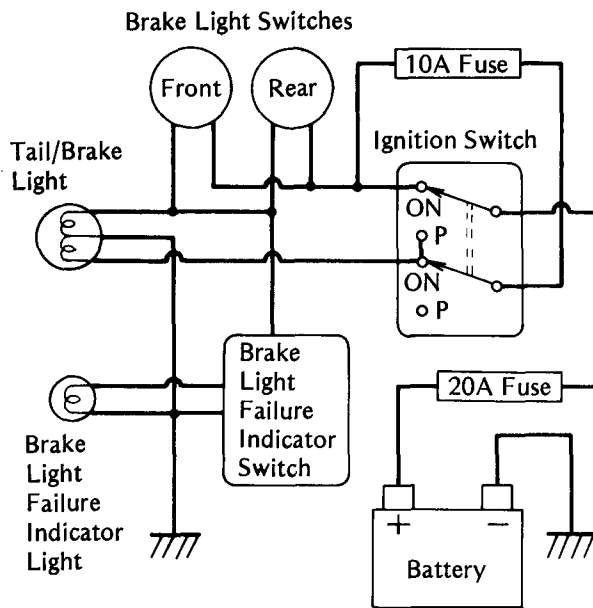

The front brake light switch, mounted on the front brake lever holder, is actuated when pressed by the front brake lever. The front brake light switch never requires adjustment, and so is not designed to be adjusted. It cannot be disassembled for repair and must be replaced when defective.

The rear brake light switch is a plunger type switch actuated by a spring attached to the rear brake pedal. It can be adjusted by changing its position higher or lower in the mounting bracket (Pg. 25).

The motorcycle on KZ750-E contains two tail/brake lights which are connected in parallel for a safety device. When one filament burns out, the other one continues to work.

The brake light failure indicator switch is in the brake light circuit on KZ750-H as a warning device to indicate whether or not the brake light is functioning properly during vehicle operation. Brake light failure may be due to a burned out bulb or some other failure in the brake light circuit.

Brake light circuit inspection involves the tail/brake light(s), front brake light switch, rear brake light switch, brake light failure indicator switch, brake light failure indicator light, and wiring. The same bulb is used for both the brake light failure indicator light and low fuel warning light.

Tail/brake light trouble

If one or both of the two tail/brake lights does (do) not go on when the circuit is closed, the filament(s) is (are) probably burned out. However if the bulbs are good, check the fuses, ignition switch, battery, front brake light switch, rear brake light switch, wiring, and

Front brake light switch inspection

- Remove the headlight unit (Pg. 129).
- Disconnect the front brake light switch leads (brown and blue).
- Set an ohmmeter to the $\times 1 \Omega$ range, connect the meter to the switch terminals, and determine whether or not there is continuity whenever the front brake lever is squeezed.

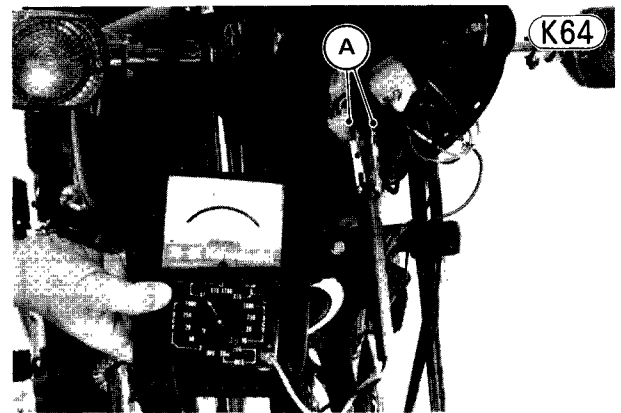

A. Front Brake Light Switch Leads

- If there is no continuity, replace the switch.

Rear brake light switch inspection

- Disconnect the rear brake light switch leads (blue and brown) in the right side cover.
- Inspect in the same way that the front brake light switch was inspected. If there is no continuity whenever the rear brake pedal is depressed, replace the switch.

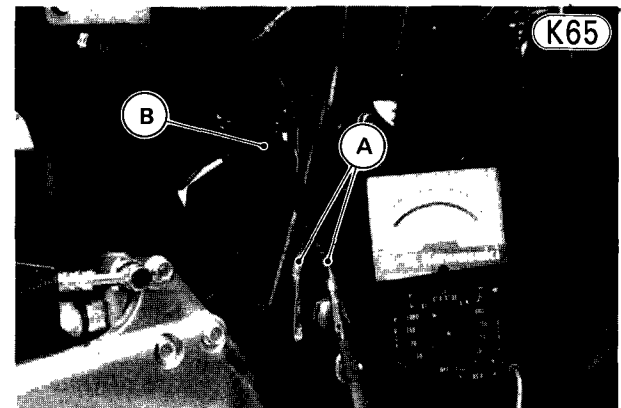

**A. Rear Brake Light Switch Leads
B. Rear Brake Light Switch**

Brake light failure indicator switch inspection

Turn on the ignition switch. Watching the indicator light (stop lamp), apply and then release either brake. Next, with the tail/brake light bulb removed, do the same above. If the indicator lights operates as shown in Table K19, the brake light failure indicator switch and

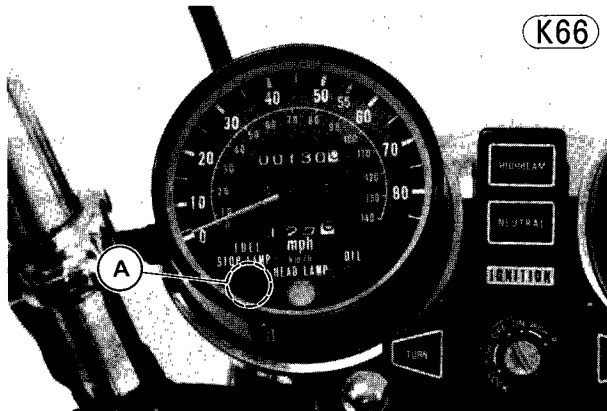

A. Indicator Light

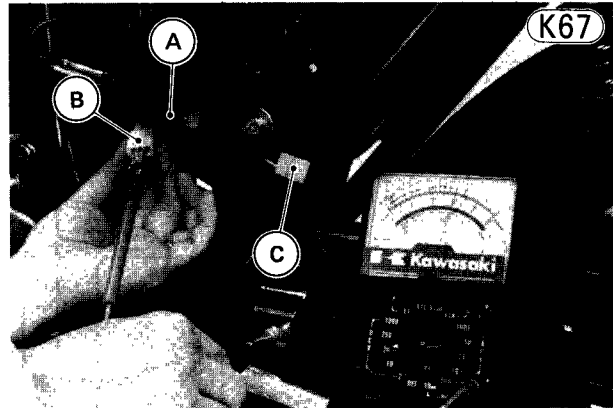

A. Brake Light Failure Indicator Switch
B. 3-pin Socket C. 3-pin Plug

Table K19 Brake Light Failure Indicator Switch Test

		Brake Lever or Pedal	
		Applied	Released
Tail/Brake Light Bulb	In place	Goes On	Goes Off
	Out of place	Goes On	Flashes

If the brake light failure indicator does not function properly, find out whether the brake light wiring is defective or the failure indicator switch is defective. The easiest way to test the failure indicator switch is to install and check the suspect switch on a motorcycle with a known good brake light circuit. When this method is impossible, check the circuit as follows (the battery must be charged).

(1) Brake light wiring inspection:

- Check brake light operation and replace any defective parts. The brake light must go on only when the brake is applied.
- Remove the left side cover, open the electrical cover, and disconnect the indicator switch 3-pin plug.
- Set an ohmmeter to the x 1 Ω range and voltmeter to the 20V DC range. Check the wiring as shown in Table K20.

CAUTION To prevent a meter burning, turn off the ignition switch while using an ohmmeter.

If the meter does not read according to this table, there may be an open or short. In case the voltage of the green/white lead shows 0 V, the indicator bulb may be burned out.

(2) Brake light failure indicator switch inspection:

- Make sure that the brake light operates properly, and that the brake light wiring is not damaged.
- Connect the indicator switch 3-pin connector.
- Measure the voltage at the 3-pin connector as shown in Table K21.

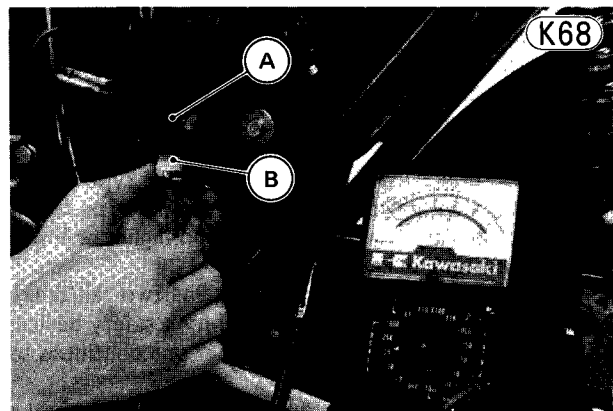

A. Brake Light Failure Indicator Switch
B. 3-pin Connector

Table K20 Brake Light Wiring Inspection

Meter Range	Connections	Brake	Reading
20V DC	Meter (+) Lead → Blue Lead	Apply	Battery Voltage
	Meter (-) Lead → Chassis Ground	Release	0 V
	Meter (+) Lead → Green/White Lead	—	Battery Voltage
	Meter (-) Lead → Chassis Ground	—	0 V
x 1 Ω	Black/Yellow Lead ↔ Chassis Ground	—	0 Ω

Table K21 Indicator Switch Inspection

Meter Range	Connections	Brake	Reading
20V DC	Meter (+) Lead → Yellow Lead	Apply	Battery Voltage
	Meter (-) Lead → Chassis Ground	Release	0 V
	Meter (+) Lead → Green/White Lead	Apply	0 V
	Meter (-) Lead → Chassis Ground	Release	Battery Voltage

If any one of the meter readings shows an improper value, the brake light failure indicator switch is defective.

Turn Signal and Hazard Circuit

A wiring diagram of the turn signal circuit is shown in Fig. K69. When the ignition switch is on and the turn signal switch is turned to R or L, a ground is provided for the circuit so current can flow. Current to the right or left turn signals flows through the closed contacts and the resistance wire inside the turn signal relay, and the turn signals go on. The resistance wire quickly heats up, expands, and allows a spring to pull the contacts open. When the contacts have opened, the circuit is broken, the turn signals go off, and the resistance wire cools and contracts, closing the contacts so that the cycle can begin again. The indicator light in the turn signal circuit flashes on and off with the turn signals to indicate that they are working properly. When the hazard switch is pushed with the ignition switch in the "ON" or "PARK" positions, all the turn signal lights and indicator lights flash on and off.

Turn Signal and Hazard Circuit

K69

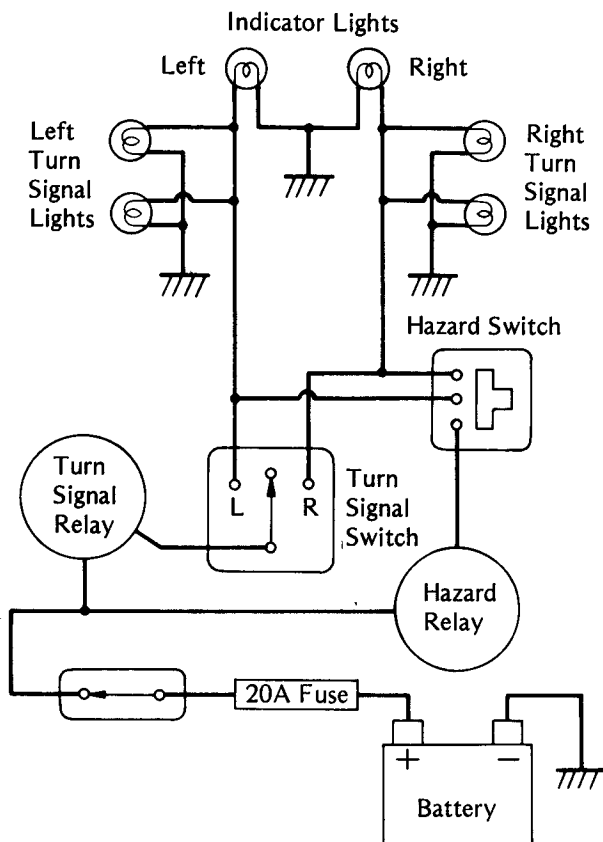

Since the turn signal relay is designed to operate correctly only when two turn signals (one front and one rear) and the turn signal indicator light are properly connected in the circuit, trouble may result from a burned out bulb, a bulb of incorrect wattage, loose

general, if the trouble with the circuit is common to both right and left turn signals, it is probably caused by a defective turn signal relay, although it may be due to a bad switch, wiring, or battery. If the trouble is with only one side — either right or left — then the relay is not at fault since the same relay is used for both side.

Turn Signal Relay

K70

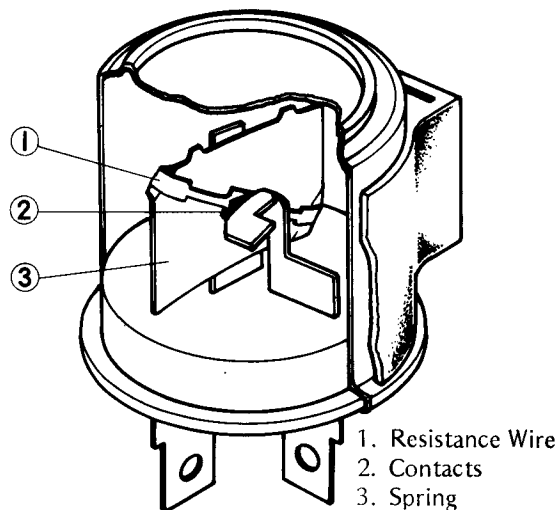

Turn signal trouble

- (1) Neither right nor left turn signals come on at all:
 - Check that battery voltage is normal.
 - Remove the left side cover, and open the electrical cover.
 - Unplug the brown lead and orange/green lead from the relay, and use an ohmmeter to check that there is continuity (close to zero ohms) between the relay terminals. If there is no ohmmeter reading, or if there is several ohms resistance, replace the relay with a new one.

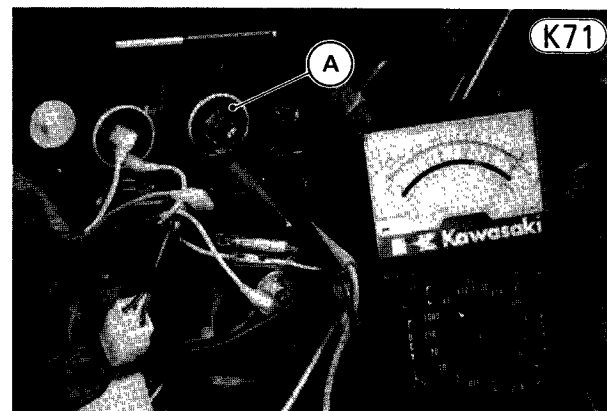

A. Turn Signal Relay

- If the relay checks good, turn the meter to the 20V DC range, connect the (+) meter lead to the brown lead that was disconnected from the relay, and connect the (-) meter lead to the orange lead. With

246 MAINTENANCE—ELECTRICAL

switch to the R and then to the L position. The meter should register battery voltage at either position. If it does not, the fuse, ignition switch, or wiring is at fault. If battery voltage is read on the meter but the turn signals still will not work when the relay is reconnected, then recheck all wiring connections.

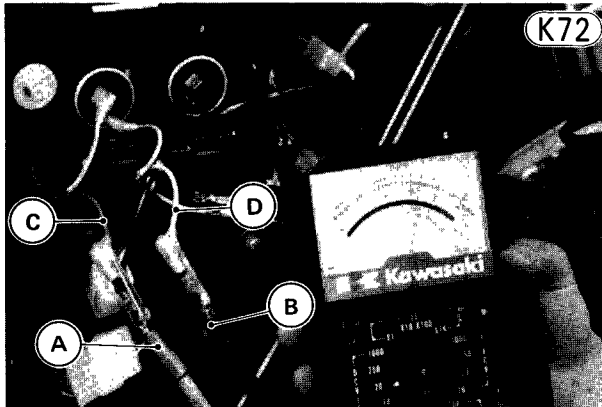

A. Meter (+) Lead **C. Brown Lead**
B. Meter (-) Lead **D. Orange Lead**

- (2) Both right or both left turn signal come on and stay on or flash too slowly:
 - Check that battery voltage is normal.
 - Check that all wiring connections are good.
 - Check that the turn signal bulbs and indicator bulbs are of the correct wattage.
 - If all of the above check good, replace the relay.
- (3) A single light on one side comes on and stays on:
 - Either the light that does not come on is burned out or of the incorrect wattage, or the wiring is broken or improperly connected.
- (4) Neither light on one side comes on:
 - Unless both lights for that side are burned out, the trouble is with the turn signal switch.
- (5) Flashing rate is too fast:
 - If this occurs on both the right and left sides, check that the battery is not being overcharged (indicating a defective regulator). If the alternator and the battery voltage are normal, replace the turn signal relay.
 - If this occurs on only one side, one or both of the turn signal bulbs are of too high a wattage.

Testing the hazard circuit

Before testing the hazard circuit, check the ignition switch connections and turn signal operation.

- Table K22 shows the internal connections of the hazard switch. To check the switch, disconnect the 6-pin connector (KZ750-E) or 9-pin connector (KZ750-H) from the left-hand switch under the fuel tank, and use an ohmmeter to verify that there is continuity between all the connections that are listed in the table. If the switch has an open or short, the switch

Table K22 Hazard Switch Connections

Color	Green	Orange/Green	Gray
Off			
On	●—————●—————●		

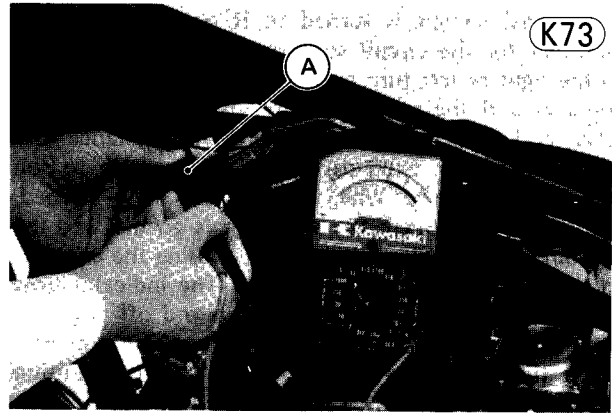

A. 6-pin (or 9-pin) connector

- Remove the left side cover, and open the electrical cover.
- Disconnect the hazard relay leads, and check the resistance between the relay terminals. There should be 60 Ω . If there is no ohmmeter reading, or if there is zero ohms resistance, replace the relay with a new one.

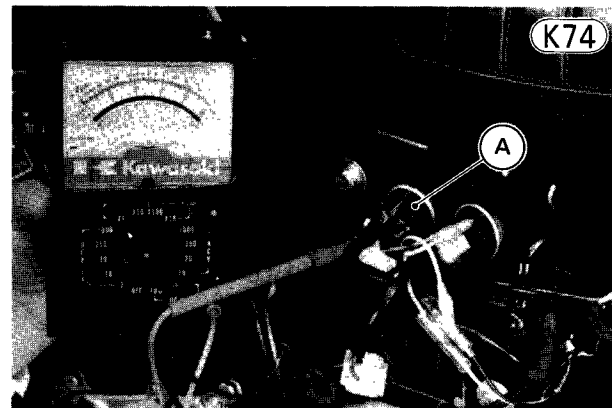

A. Hazard Relay

- If the relay and hazard switch are good, go on to the following check.
- Connect the suitable lead between the hazard switch orange/green leads of the connector.
- Set the multimeter to the 20V DC range, connect the + meter lead to the gray lead from the left switch housing, and connect the - meter lead to the gray lead from the main harness. With the hazard switch on, first turn the ignition switch to the ON position and then to the P(Park) position. Do the same with the green lead from the left switch housing. The meter should register battery voltage at both positions. If it

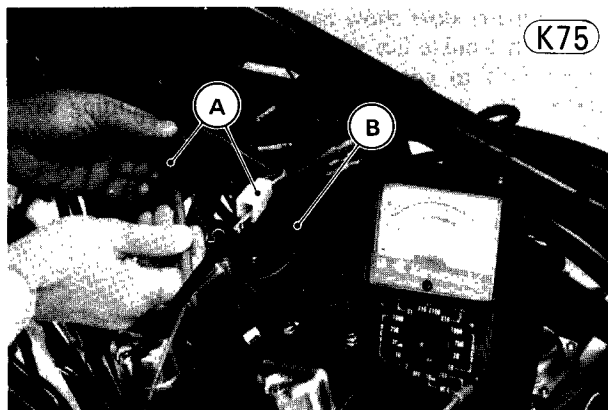

K75

A. 6-pin (or 9-pin) Connectors B. Suitable Lead

HORN

The horn construction is shown in Fig. K76. When the horn button is pressed with the ignition switch on, the horn is grounded to complete the horn circuit. Current then flows through the horn contacts and horn coil, magnetizing the iron core. The magnetized iron core pulls on the armature and diaphragm assembly, the movement of which pushes open the contacts, interrupting the current flow. Since the core now loses its magnetism, the armature and diaphragm assembly springs back to its original position, closing the contacts. This cycle repeats until the horn button is released. Since each cycle takes only a fraction of a second, the diaphragm moves fast enough to produce sound.

Horn Construction

K76

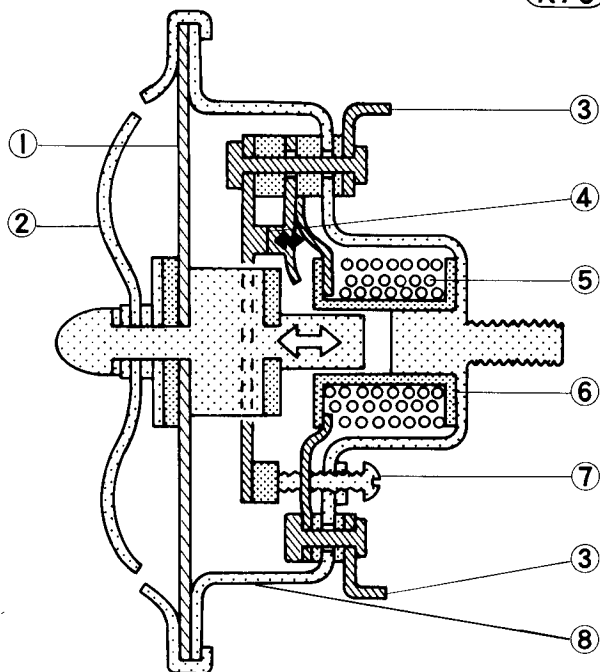

1. Diaphragm
2. Ringer Disc
3. Horn Terminal
4. Armature
5. Coil
6. Insulator
7. Adjusting Screw
8. Locknut

The contacts wear down after long use, requiring adjustment from time to time. If the horn itself is determined to be at fault and adjustment fails to correct the trouble, the contacts or some other component in the horn is defective. The horn cannot be disassembled and must be replaced if defective.

Horn adjustment

The horn contacts wear down after long use and may need to be adjusted from time to time. Turning in the adjusting screw compensates for contact wear. If satisfactory horn performance cannot be obtained by this adjustment when the rest of the electrical system is functioning properly, the horn must be replaced. It cannot be disassembled.

WARNING To avoid serious burn, never touch a hot engine or exhaust pipe during horn adjustment.

CAUTION Do not turn the adjusting screw in too far, since doing so will increase horn current with the possibility of burning out the horn coil.

- Disconnect the horn black lead; and connect an ammeter in series to the horn circuit. The (+) ammeter lead goes to the horn terminal and the (-) ammeter lead to the black lead.

Horn Current Measurement

K77

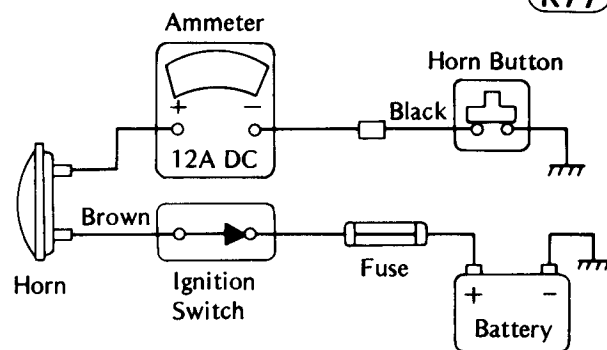

- Fully loosen the adjusting screw locknut.
- Turn on the ignition switch, and keep the horn button pressed while turning the horn adjusting screw. Adjust for the best horn sound while keeping the current between 2.0 ~ 3.0 amperes.

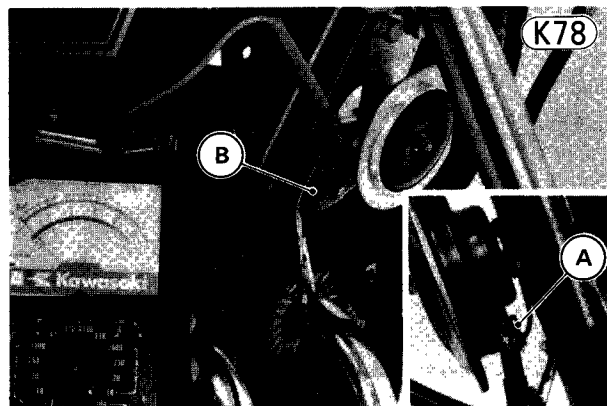

K78

248 MAINTENANCE—ELECTRICAL

- Tighten the adjusting screw locknut.

NOTE: The horn will not sound properly if it is mounted incorrectly or if any cable or other part is touching it.

Horn trouble

- Check that battery voltage is normal.
- Check that the adjusting screw is turned in or out too far.
- Disconnect the leads to the horn, and connect to the horn terminals a multimeter set to the $\times 1 \Omega$ range to check for continuity (close to zero ohms). If the reading is several ohms or if there is no reading at all, replace the horn.

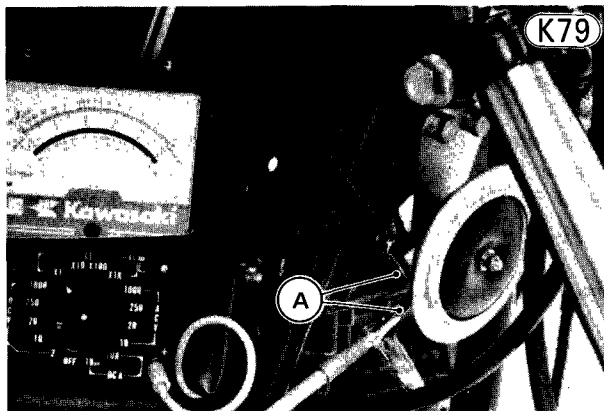

A. Horn Terminals

- If the reading is very close to zero, set the multimeter to the 20V DC range, and connect the meter to the leads that were disconnected from the horn. The (+) meter lead goes to the brown lead, and the (–) meter lead goes to the black lead. With the ignition switch on, press the horn button. The meter should register battery voltage. If it does not, the fuse, ignition switch, or the wiring is at fault.

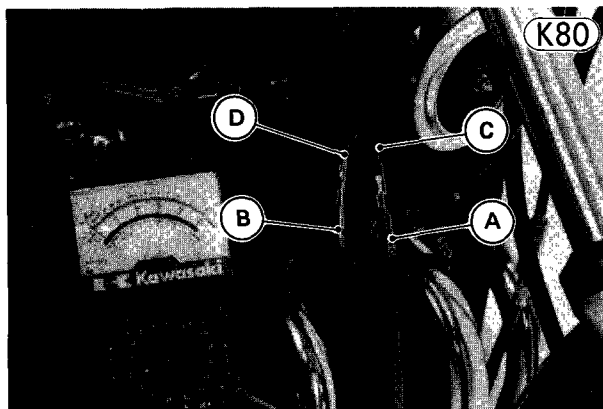

A. Meter (+) Lead

C. Brown Lead

- If the meter does show battery voltage, indicating that the horn trouble lies within the horn itself, and adjustment fails to correct the trouble, replace the horn.

NOTE: Do not loosen the armature mounting since doing so would alter the armature position such that the horn would probably have to be replaced.

LOW FUEL WARNING SYSTEM (on KZ750-H)

This is a system that warns the rider when there is only about $\frac{1}{5}$ tank (2.3 liters) of fuel remaining. It consists of a fuel level sensor inside the tank and a warning light. The same bulb is used for both the low fuel warning light and brake light failure indicator light.

Low Fuel Warning Circuit

K81

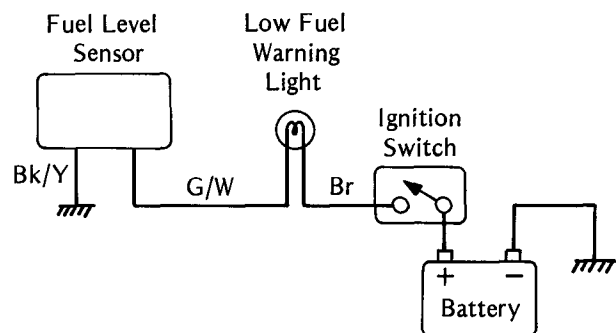

When the ignition switch is turned on, the warning light does not come on if the fuel level is higher than the warning level. If the fuel level is low, the light comes on and stay on continuously until fuel is added.

Warning system trouble

Before starting to troubleshoot the fuel warning system, first check that the battery is good (Pg. 218) and make sure that all connectors in the system are clean and tight.

- (1) Fuel level is low but the warning light does not come on.

- Check that the warning light comes on when the

- Disconnect the 2-pin connector to the fuel level sensor, set the meter to the 20V DC or higher range, and connect the + meter lead to the green/white and the - lead to the black/yellow wire.

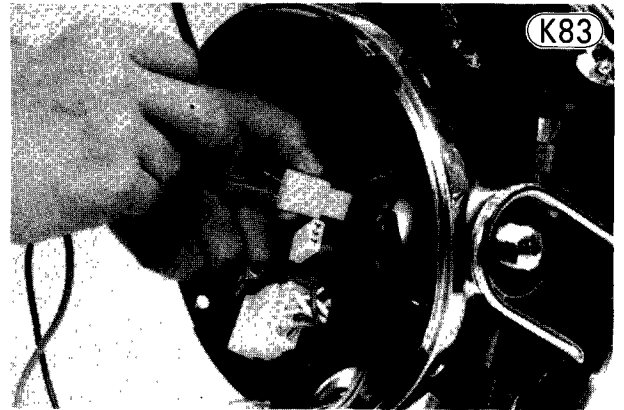

- Turn on the ignition switch and read the meter. If it does not read battery voltage, the wiring is at fault.
 - If the meter does read battery voltage, the sensor is defective.
- (2) Fuel level is not low but the warning light stays on continuously.
 - Check that the brake light circuit is good. If it is good, the sensor is bad.
 - (3) Warning light goes on and off irregularly.
 - Check that the fuel is well above the low level.
 - Check that the wiring is not shorting out against other parts.
 - Check that the battery charging voltage is normal (Pg. 223).
 - If all the above checks are good, check that the sensor is not internally shorting intermittently.

Table K23 Gauge Resistance

Connections	Reading
One meter lead Brown lead	60~80 Ω
The other meter lead → Black/Yellow lead	

- If the meter checks good, inspect all the related wiring and connectors. Replace any that shows damage.

SPEEDOMETER, TACHOMETER

The speedometer and tachometer are sealed units which cannot be disassembled. If either fails to work satisfactorily, it must be replaced as a complete unit.

The speedometer and tachometer lights and the indicator lights are independent and can be removed for replacement if necessary.

VOLTMETER

The voltmeter shows the battery voltage when the engine is not turning and the battery charging voltage when the engine is turning.

If the voltmeter does not appear to be functioning properly, check it by the following procedure.

- Remove the headlight unit (Pg. 129), and disconnect the 6-pin connector (KZ750-E) or 3-pin connector (KZ750-H) from the meter. Check the resistance of the meter using an ohmmeter as shown in Table K23. If the resistance in this test is found to be less than the proper value, there is a short in the meter. No reading (∞) indicates an open circuit. In either case, replace

Troubleshooting—Guide

Engine Doesn't Start, Starting Difficulty

Starter motor not rotating

- Clutch lever not pulled
- Starter lockout switch trouble
- Starter motor trouble
- Battery voltage low
- Relay not contacting or operating
- Starter button not contacting
- Wiring open or shorted
- Ignition switch trouble
- Engine stop switch trouble
- Engine stop switch off
- Fuse blown

Starter motor rotating but engine doesn't turn over

- Starter motor clutch trouble

Engine won't turn over

- Valve seizure
- Valve lifter seizure
- Cylinder, piston seizure
- Crankshaft seizure
- Connecting rod small end seizure
- Connecting rod big end seizure
- Transmission gear or bearing seizure
- Camshaft seizure
- Secondary shaft bearing seizure
- Primary chain broken

No fuel flow

- No fuel in tank
- Sticking of the valve in the automatic fuel tap
- Fuel tap vacuum hose clogged
- Tank cap air vent obstructed
- Fuel tap clogged
- Fuel line clogged
- Float valve clogged

Engine flooded

- Fuel level too high
- Float valve worn or stuck open
- Starting technique faulty
(When flooded, push the starter button with the throttle fully open to allow more air to reach the engine.)

No spark; spark weak

- Battery voltage low
- Ignition switch not on
- Engine stop switch turned off
- Spark plug dirty, broken, or maladjusted
- Spark plug cap or high tension wiring trouble
- Spark plug cap not in good contact
- Spark plug incorrect
- IC igniter trouble
- Pick-up coil trouble
- Ignition coil trouble
- Ignition or engine stop switch shorted
- Wiring shorted or open

Compression low

- Spark plug loose
- Cylinder head not sufficiently tightened down
- No valve clearance

- Piston ring bad (worn, weak, broken, or sticking)
- Piston ring/land clearance excessive
- Cylinder head gasket damaged
- Cylinder head warped
- Valve spring broken or weak
- Valve not seating properly (valve bent, worn, or carbon accumulation on the seating surface)

Poor Running at Low Speed

Spark weak

- Battery voltage low
- Spark plug dirty, broken, or maladjusted
- Spark plug cap or high tension wiring trouble
- Spark plug cap shorted or not in good contact
- Spark plug incorrect
- IC igniter trouble
- Pick-up coil trouble
- Ignition coil trouble

Fuel/air mixture incorrect

- Pilot screw maladjusted
- Pilot jet, or air passage clogged
- Pilot jet bleed holes clogged
- Main jet clogged
- Pilot passage clogged
- Air cleaner clogged, poorly sealed or missing
- Choke valve closed
- Fuel level too high or too low
- Fuel tank air vent obstructed
- Carburetor holder loose
- Air cleaner duct loose

Compression low

- Spark plug loose
- Cylinder head not sufficiently tightened down
- No valve clearance
- Cylinder, piston worn
- Piston ring bad (worn, weak, broken or sticking)
- Piston ring/land clearance excessive
- Cylinder head gasket damaged
- Cylinder head warped
- Valve spring broken or weak
- Valve not seating properly (valve bent, worn, or carbon accumulation on the seating surface)

Other

- Timing not advancing (spring broken or stretched)
- Carburetors not synchronizing
- Vacuum piston doesn't slide smoothly
- Damaged vacuum piston diaphragm
- Engine oil viscosity too high
- Brake dragging
- Air suction valve trouble
- Vacuum switch valve trouble

Poor Running or No Power at High Speed

Firing incorrect

252 TROUBLESHOOTING—GUIDE

- Spark plug cap or high tension wiring trouble
- Spark plug cap shorted or not in good contact
- Spark plug incorrect
- IC igniter trouble
- Pick-up coil trouble
- Ignition coil trouble
- Timing not advancing

Fuel/air mixture incorrect

- Choke valve closed
- Main jet clogged or wrong size
- Jet needle or needle jet worn
- Air jet clogged
- Fuel level too high or too low
- Bleed holes of main jet bleed pipe or needle jet clogged
- Air cleaner clogged, poorly sealed, or missing
- Air cleaner duct poorly sealed
- Water or foreign matter in fuel
- Carburetor holder loose
- Air cleaner duct loose
- Fuel tank air vent obstructed
- Fuel tap clogged
- Fuel line clogged

Compression low

- Spark plug loose
- Cylinder head not sufficiently tightened down
- No valve clearance
- Cylinder, piston worn
- Piston ring bad (worn, weak, broken, or sticking)
- Piston ring/land clearance excessive
- Cylinder head gasket damaged
- Cylinder head warped
- Valve spring broken or weak
- Valve not seating properly (valve bent, worn or carbon accumulation on the seating surface.)

Knocking

- Carbon built up in combustion chamber
- Fuel poor quality or incorrect
- Spark plug incorrect

Miscellaneous

- Butterfly valve won't fully open
- Vacuum Piston doesn't slide smoothly
- Damaged vacuum piston diaphragm
- Timing not advancing
- Brake dragging
- Clutch slipping
- Overheating
- Engine oil level too high
- Engine oil viscosity too high
- Air suction valve trouble
- Vacuum switch valve trouble

Overheating

Firing incorrect

- Spark plug dirty, broken, or maladjusted
- Spark plug incorrect

Fuel/air mixture incorrect

- Main jet clogged or wrong size
- Fuel level too low
- Carburetor holder loose

- Air cleaner duct poorly sealed
- Air cleaner clogged

Compression high

- Carbon built up in combustion chamber

Engine load faulty

- Clutch slipping
- Engine oil level too high
- Engine oil viscosity too high
- Brake dragging

Lubrication inadequate

- Engine oil level too low
- Engine oil poor quality or incorrect

Clutch Operation Faulty

Clutch slipping

- No clutch lever play
- Friction plate worn or warped
- Steel plate worn or warped
- Clutch spring broken or weak
- Clutch release maladjusted
- Clutch cable maladjusted
- Clutch inner cable catching
- Clutch release mechanism trouble
- Clutch hub or housing unevenly worn

Clutch not disengaging properly

- Clutch lever play excessive
- Clutch plate warped or too rough
- Clutch spring tension uneven
- Engine oil deteriorated
- Engine oil viscosity too high
- Engine oil level too high
- Clutch housing frozen on drive shaft
- Clutch release mechanism trouble
- Loosen clutch hub locknut

Gear Shifting Faulty

Doesn't go into gear; shift pedal doesn't return

- Clutch not disengaging
- Shift fork bent or seized
- Gear stuck on the shaft
- Shift drum positioning pin binding
- Shift return spring weak or broken
- Shift return spring pin loose
- Shift mechanism arm spring broken
- Shift lever broken
- Shift mechanism arm broken
- Shift pawl broken

Jumps out of gear

- Shift fork worn
- Gear groove worn
- Gear dogs, dog holes, and/or dog recesses worn
- Shift drum groove worn
- Shift drum positioning pin spring weak or broken
- Shift fork pin worn
- Drive shaft, output shaft, and/or gear splines worn

Overshifts

- Shift drum positioning pin spring weak or broken
- Overshift limiter pawl broken

Abnormal Engine Noise

Knocking

- Carbon built up in combustion chamber
- Fuel poor quality or incorrect
- Spark plug incorrect
- Overheating

Piston slap

- Cylinder/piston clearance excessive
- Cylinder, piston worn
- Connecting rod bent
- Piston pin, piston holes worn

Valve noise

- Valve clearance incorrect
- Valve spring broken or weak
- Camshaft bearing worn
- Valve lifter worn

Other noise

- Connecting rod small end clearance excessive
- Connecting rod big end clearance excessive
- Piston ring worn, broken, or stuck
- Piston seizure, damage
- Cylinder head gasket leaking
- Exhaust pipe leaking at cylinder head connection
- Crankshaft runout excessive
- Engine mounts loose
- Crankshaft bearing worn
- Primary chain worn
- Camshaft chain tensioner trouble
- Camshaft chain, sprocket, guide worn
- Loose alternator rotor
- Air suction valve damaged
- Vacuum switch valve damaged

Abnormal Drive Train Noise

Clutch noise

- Weak or damaged shock rubber damper
- Clutch housing/friction plate clearance excessive

Transmission noise

- Bearing worn
- Transmission gear worn or chipped
- Metal chip jammed in gear teeth
- Engine oil insufficient

Drive chain noise

- Drive chain adjusted improperly
- Chain worn
- Rear, engine sprocket worn
- Chain lubrication insufficient
- Rear wheel misaligned

Abnormal Frame Noise

Front fork noise

- Oil insufficient or too thin
- Spring weak or broken

Rear shock absorber noise

- Shock absorber defective

Disc brake noise

- Pad installed incorrectly
- Pad surface glazed

Caliper trouble

Cylinder damaged

Other noise

Bracket, nut, bolt, etc. not properly mounted or tightened

Exhaust Smokes Excessively

White smoke

- Piston oil ring worn
- Cylinder worn
- Valve oil seal damaged
- Valve guide worn
- O ring at the cylinder oil passage orifices are damaged
- Engine oil level too high

Black smoke

- Air cleaner clogged
- Main jet too large or fallen off
- Choke valve closed
- Fuel level too high

Brown smoke

- Main jet too small
- Fuel level too low
- Air cleaner duct loose
- Air cleaner poorly sealed or missing

Handling and/or Stability Unsatisfactory

Handlebar hard to turn

- Steering stem locknut too tight
- Bearing ball damaged
- Race dented or worn
- Steering stem lubrication inadequate
- Steering stem bent
- Tire air pressure too low

Handlebar shakes or excessively vibrates

- Tire worn
- Swing arm needle bearing worn
- Rim warped, or not balanced
- Front, rear axle runout excessive
- Wheel bearing worn
- Handlebar clamp loose
- Steering stem head bolt and/or clamp bolt loose

Handlebar pulls to one side

- Frame bent
- Wheel misalignment
- Swing arm bent or twisted
- Steering stem bent
- Front fork bent
- Right/left fork legs oil level uneven
- Right/left fork legs air pressure uneven
- Right/left rear shock absorbers unbalanced

Shock absorption unsatisfactory

- Too hard:
 - Front fork oil excessive
 - Front fork oil viscosity too high
 - Front fork air pressure too high
 - Tire air pressure too high
 - Rear shock absorber maladjusted

254 TROUBLESHOOTING—GUIDE

Too soft:

- Front fork oil insufficient and/or leaking
- Front fork oil viscosity too low
- Front fork air pressure too low
- Front fork, rear shock absorber spring weak
- Rear shock absorber oil leaking

Brakes Don't Hold

Disc brake

- Air in the brake line
- Pad or disc worn
- Brake fluid leak
- Disc warped
- Contaminated pad
- Brake fluid deteriorated
- Primary or secondary cup worn
- Master cylinder scratched inside

Oil Pressure Indicator Light Goes On

- Engine oil pump defective
- Engine oil pump screen clogged
- Engine oil level too low
- Engine oil viscosity too low
- Camshaft bearings worn
- Crankshaft bearings worn
- Oil pressure switch trouble
- Wiring trouble
- Relief valve stuck open

Battery Discharged

- Battery faulty (e.g., plates sulphated, shorted through sedimentation, electrolyte level too low)
- Battery leads making poor contact
- Load excessive (e.g., bulb of excessive wattage)
- Regulator/rectifier trouble
- Ignition switch trouble
- Alternator trouble
- Wiring faulty

Battery Overcharged

- Regulator/rectifier trouble
- Battery trouble

NOTE: This is not an exhaustive list, giving every possible cause for each problem listed. It is meant simply as a rough guide to assist the troubleshooting for some of the more common difficulties. Electrical troubleshooting is not covered here due to its complexity. For electrical problems, refer to the appropriate heading in the Maintenance Section.

Appendix

Table of Contents

ADDITIONAL CONSIDERATIONS FOR RACING	256
Carburetor	256
Spark Plug	256
SPECIAL TOOLS	258
WIRING DIAGRAMS	262

M2

Spark Plug Condition



Carbon Fouling

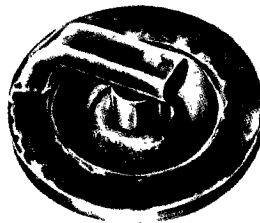

Oil Fouling

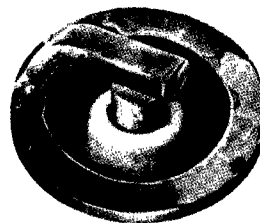

Normal Operation



Overheating

black, the plug is operating at too low a temperature and it should be replaced with the next hotter type.

The heat range of the spark plug functions like a thermostat for the engine. Using the wrong type of spark plug can make the engine run too hot (resulting in engine damage) or too cold (with poor performance, misfiring, and stalling). The standard plug has been selected to match the normal usage of this motorcycle in combined street and highway riding. Unusual riding conditions may require a different spark plug heat range. For cold weather [below 10°C (50°F)] low speed riding, it may be necessary to use a hotter spark plug (NGK B7ES or BR7ES, ND W22ES-U or W22ESR-U) to avoid fouling.

CAUTION If the spark plugs are replaced with a new one, make certain the replacement plugs have the same thread pitch and reach (length of threaded portion) as the standard plugs.

Spark Plug Reach

M3

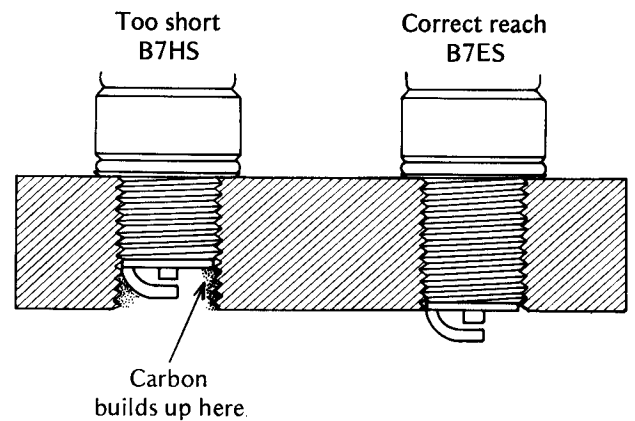

Table M1 Spark Plug Specifications

Required Plug Threads	Riding Condition	Type
Diameter: 14.0 mm Pitch: 1.25 mm Reach: 19.0 mm	Normal	NGK B8ES, ND W24ES-U ⓔ NGK BR8ES, ND W24ESR-U
	Cold weather [below 10°C(50°F)] low speed	NGK B7ES, ND W22ES-U ⓔ NGK BR7ES, ND W22ESR-U

ⓔ : European and Canadian Model

If the plug reach is too short, carbon will build up on the plug hole threads in the cylinder head, causing overheating and making it very difficult to insert the correct spark plug later.

If the reach is too long, carbon will build up on the exposed spark plug threads causing overheating, pre-ignition, and possibly burning a hole in the piston top. In addition, it may be impossible to remove the plug

258 APPENDIX
SPECIAL TOOLS

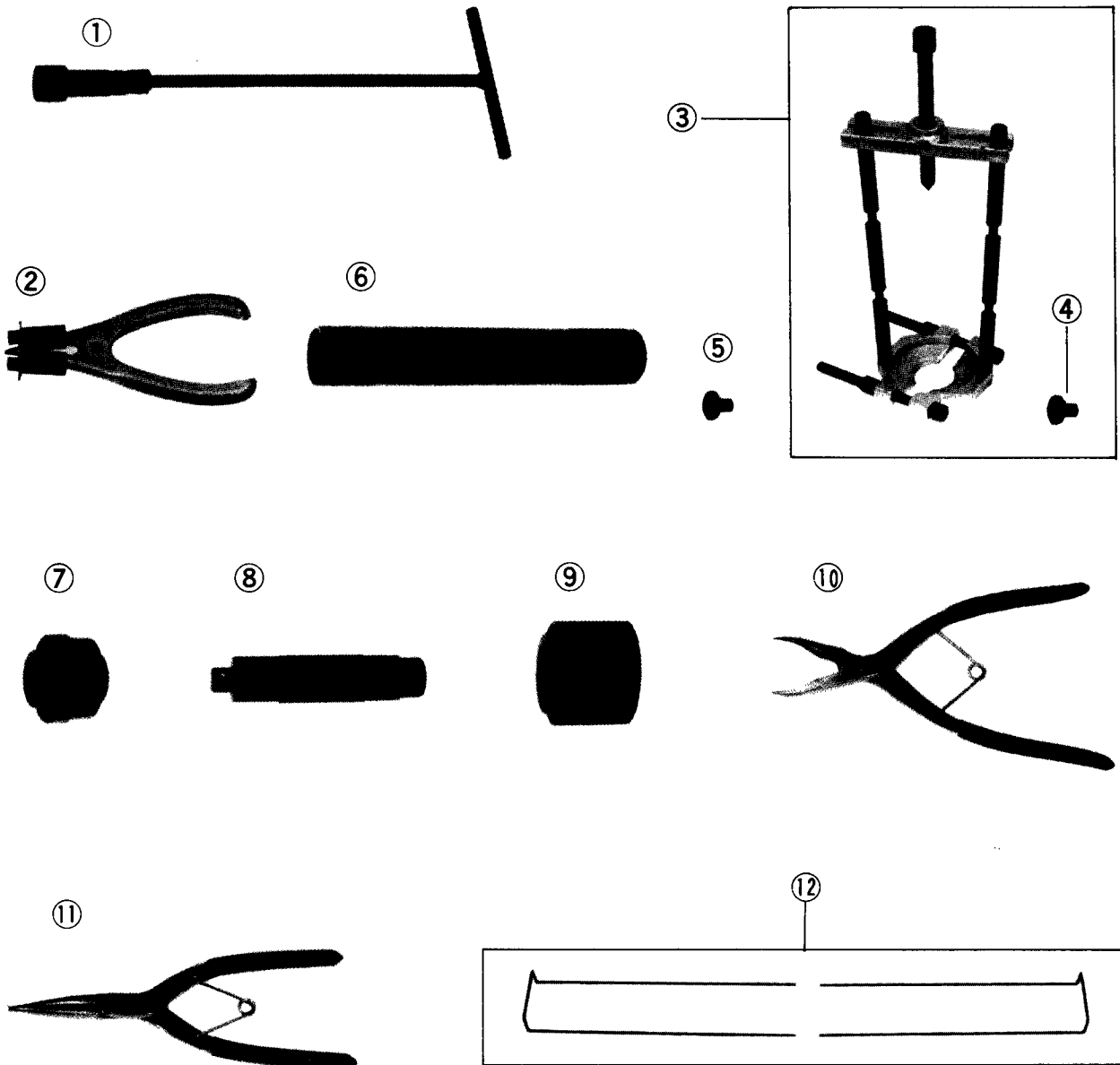

REF. NO.	PART NO.	DESCRIPTION	Q'TY
1	57001-110	SPARK PLUG WRENCH	1
2	57001-115	PISTON RING PLIERS	1
3	57001-135	BEARING PULLER	1
	(or P/N 57001-158 and 57001-136)		
4	57001-136	BEARING PULLER ADAPTER	—
5	57001-317	BEARING PULLER ADAPTER	1
6	57001-137	STEM BEARING DRIVER	1
7	57001-138	STEM CUP DRIVER	1
8	57001-139	BEARING DRIVER HOLDER	1
9	57001-141	FRONT FORK OIL SEAL DRIVER	1
10	57001-143	INSIDE CIRCLIP PLIERS	1
11	57001-144	OUTSIDE CIRCLIP PLIERS	1

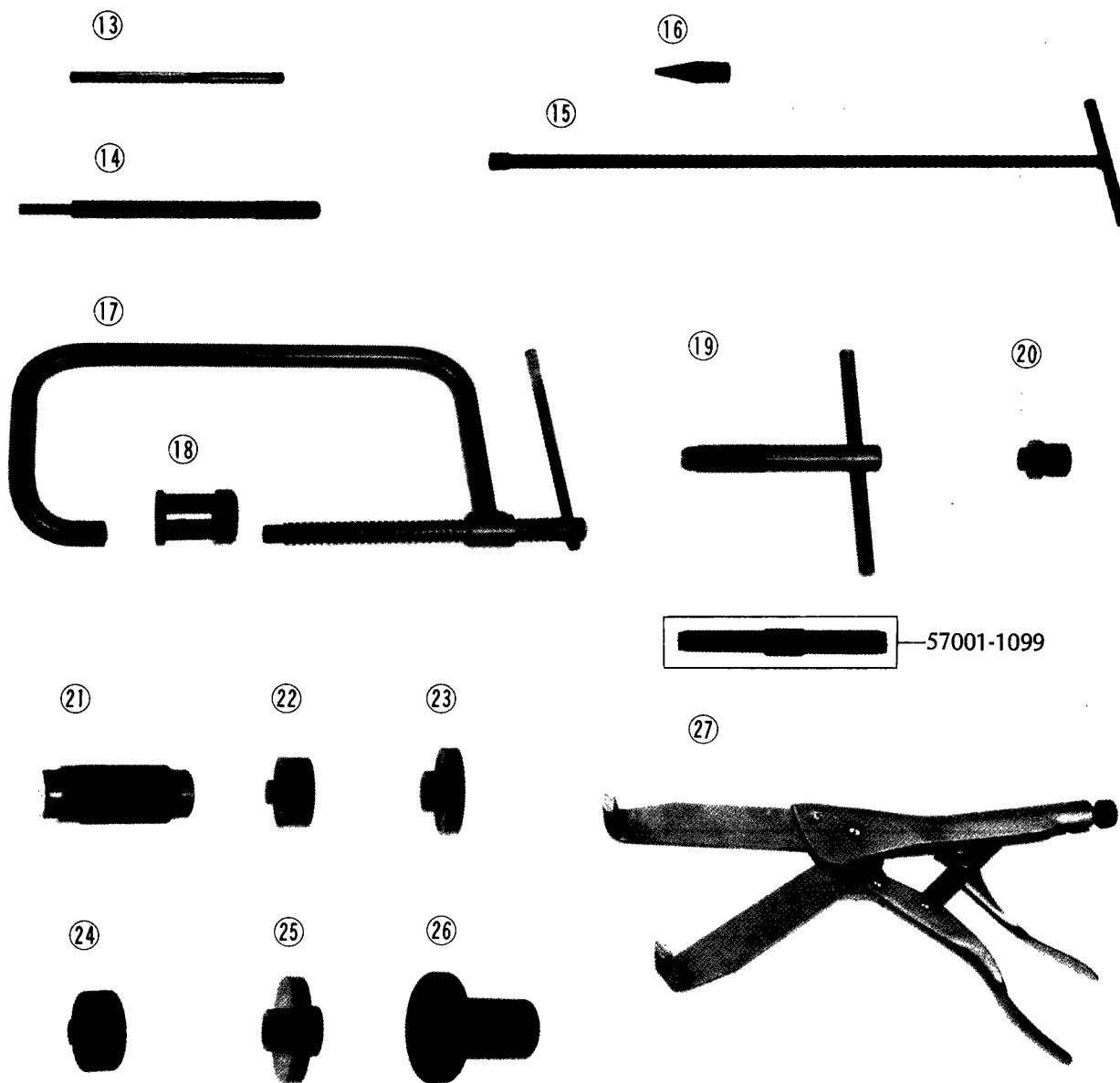

REF. NO.	PART NO.	DESCRIPTION	Q'TY
13	57001-162	VALVE GUIDE REAMER	1
14	57001-163	VALVE GUIDE ARBOR	1
15	57001-183	FRONT FORK CYLINDER HOLDER HANDLE	1
16	57001-1011	FRONT FORK CYLINDER HOLDER ADAPTER	1
17	57001-241	VALVE SPRING COMPRESSOR ASSY	1
18	57001-243	VALVE SPRING COMPRESSOR ADAPTER	1
19	57001-254 or P/N 57001-1099)	ROTOR PULLER	1
20	57001-264	OIL SEAL GUIDE	1
21	57001-286	BEARING DRIVER	1
22	57001-288	BEARING DRIVER	1
23	57001-289	BEARING DRIVER	1
24	57001-290	BEARING DRIVER	1
25	57001-296	BEARING DRIVER	1
26	57001-297	BEARING DRIVER	1

260 APPENDIX

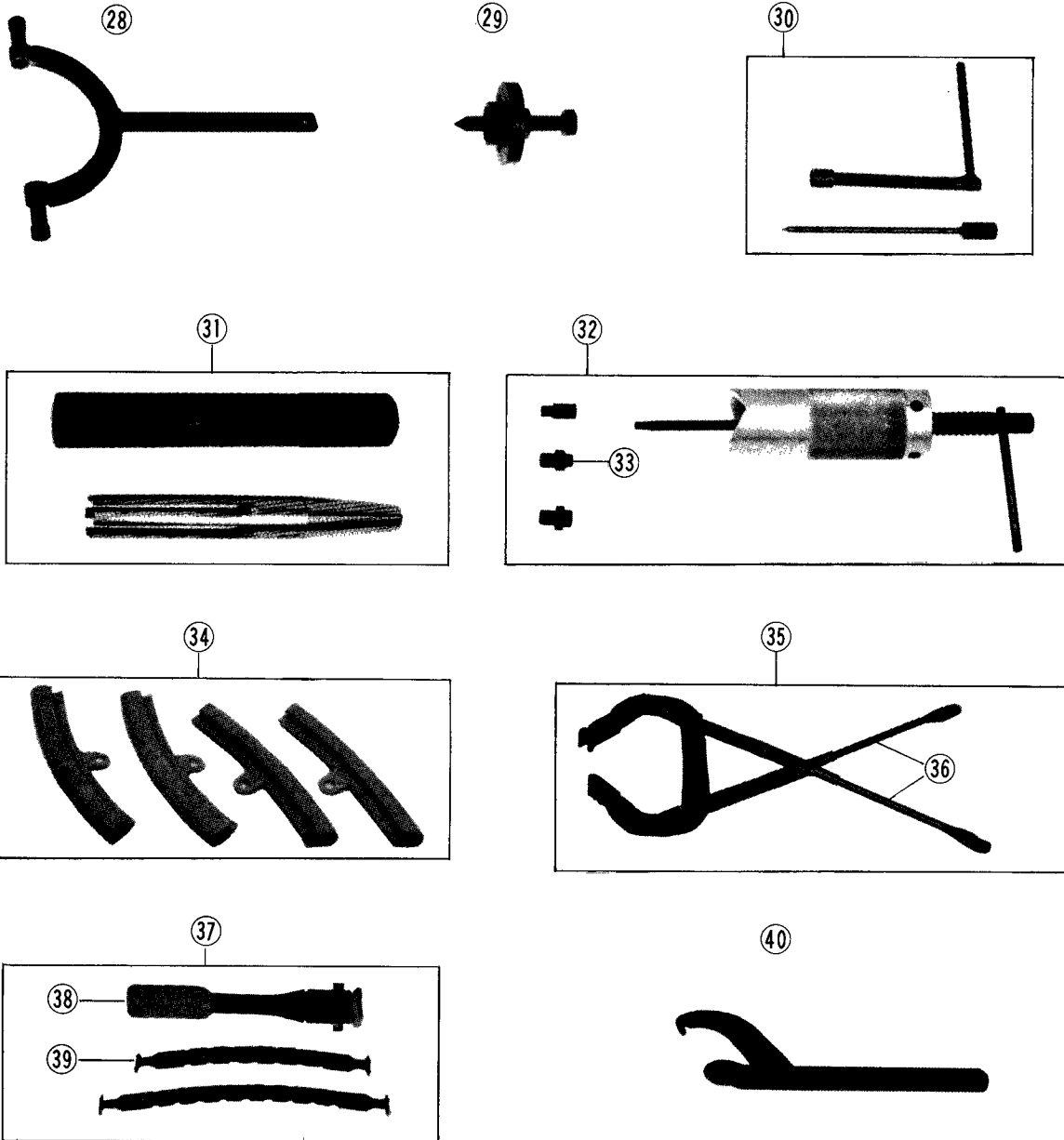

REF. NO.	PART NO.	DESCRIPTION	Q'TY
28	57001-308	ROTOR HOLDER	1
29	57001-319	GEAR PULLER & PUSHER	1
30	57001-351	BALANCE ADJUSTER	1
31	57001-380	TRANSMISSION CIRCLIP DRIVER	1
32	57001-910	PISTON PIN PULLER ASSY	1
33	57001-913	PISTON PIN PULLER ADAPTER "B"	—
34	57001-1063	RIM PROTECTORS	1 set
35	57001-1072	TIRE BEAD BREAKER ASSY	1
36	57001-1073	TIRE IRONS	—
37	57001-1094	PISTON RING COMPRESSOR ASSY	4
38	57001-1095	PISTON RING COMPRESSOR GRIP	—
39	57001-1096	PISTON RING COMPRESSOR ADAPTER	—

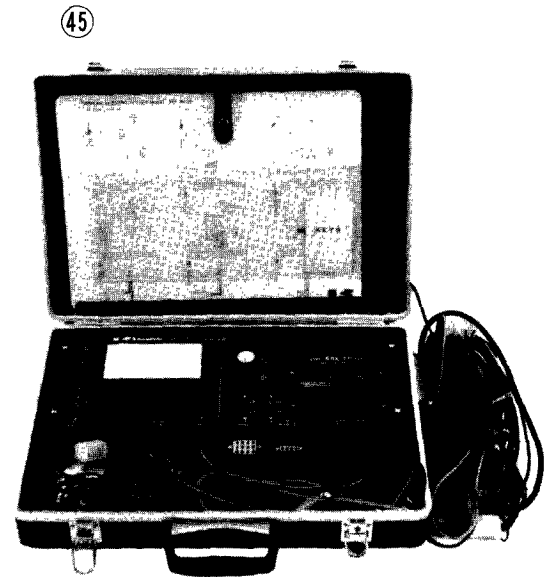
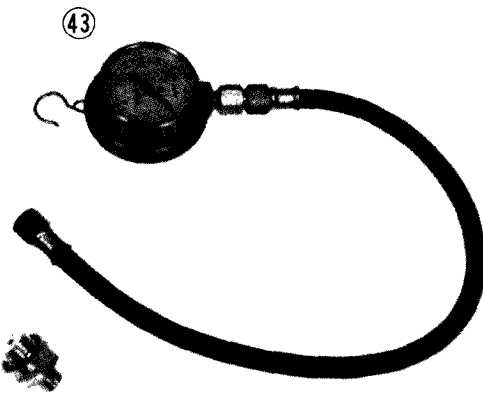
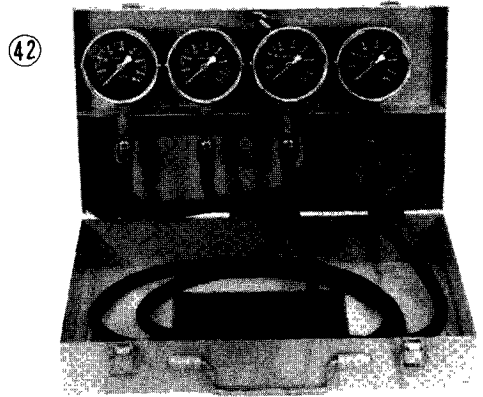
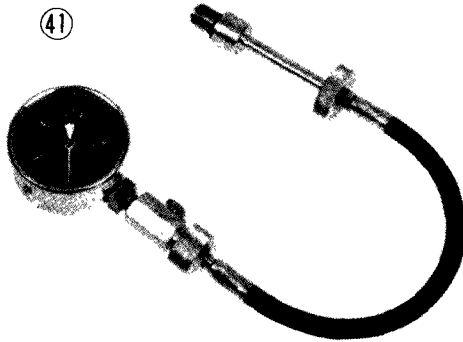

REF. NO.	PART NO.	DESCRIPTION	Q'TY
41	57001-123	COMPRESSION GAUGE ASSY	1
42	57001-127	VACUUM GAUGE SET	1
43	57001-164	OIL PRESSURE GAUGE ASSY	1
44	57001-403	OIL PRESSURE GAUGE ADAPTER	1
45	57001-980	ELECTROTESTER	1
46	57001-983	HAND TESTER	1
47	57001-1000	AIR PRESSURE GAUGE	1

262 APPENDIX

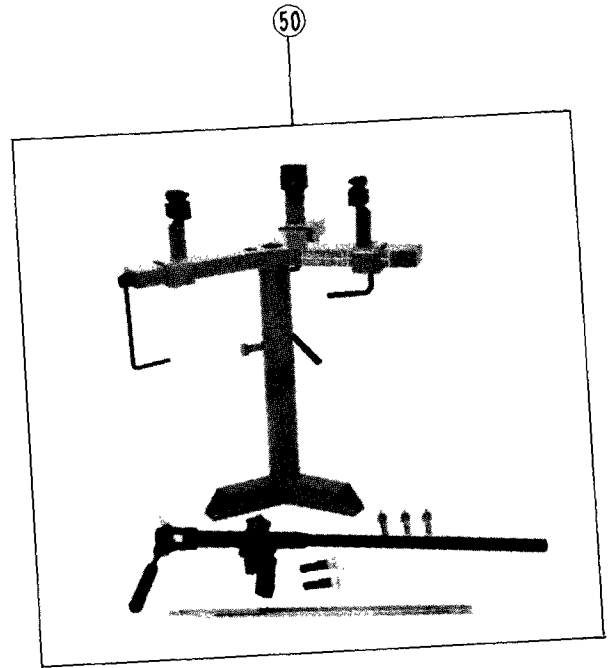
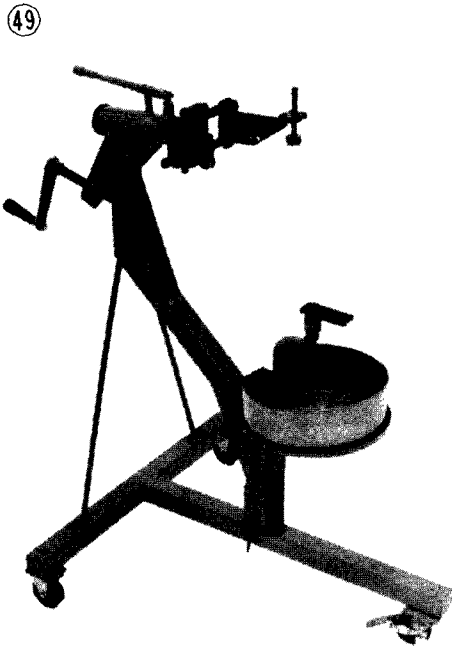

REF. NO.	PART NO.	DESCRIPTION	Q'TY
49	57001-900	ENGINE STAND	1
50	57001-1065	TIRE CHANGER	1

Supplement

This Supplement is designed to be used in conjunction with the front part of this Service Manual (up to Pg. 266). The maintenance and repair procedures described in this Supplement are only those that are unique to later year units since the first publication of this Service Manual. Complete and proper servicing of later year units therefore requires mechanics to read both this Supplement and the front part of this Service Manual.

This supplement is divided into few sections. Each section is annually added to the preceding section, and explains procedures par one year unit that are unique to the latest year unit. Complete and proper servicing of later year units therefore requires mechanics to read (1) the section corresponding to the year unit they work at, (2) the previous section(s), the text in front part of this Service Manual.

NOTE: The maintenance and repair procedures for the new variation models are newly included in this section. Unless otherwise noted, procedures for the new variation models are the same as those for their base models.

Table of Contents

SUPPLEMENT FOR 1981 MODEL	268
SUPPLEMENT FOR 1982 MODEL	285
SUPPLEMENT FOR 1983 MODEL	335
SUPPLEMENT FOR 1984 MODEL	389
SUPPLEMENT FOR 1985, 1988 MODELS	411



Supplement for 1981 Model

Table of Contents

[ALL MODELS]

MODEL IDENTIFICATION	269
SPECIFICATIONS	
SPECIFICATIONS	270
PERIODIC MAINTENANCE CHART	272
ADJUSTMENT	
REAR SHOCK ABSORBERS	273
DISASSEMBLY	
TORQUE	273
CAMSHAFT CHAIN TENSIONER	273
MAINTENANCE	
CAMSHAFT CHAIN TENSIONER	275
CYLINDER HEAD, VALVE	275
SWING ARM	275
LIGHTING SYSTEM	276
APPENDIX	
SPECIAL TOOLS	279
WIRING DIAGRAMS	281

[KZ750E, L]

DISASSEMBLY	
FUEL TANK, FUEL LEVEL SENSOR	273
REAR SHOCK ABSORBERS	274
MAINTENANCE	
LOW FUEL WARNING SYSTEM	278

[KZ750H]

MAINTENANCE	
WHEEL	275

NOTE: The service informations for the 1981 Z750L are newly included in this section. Unless otherwise noted, refer to the following 1980 model.
Z750-E1 for Z750-L1

Model Identification

KZ750-E2

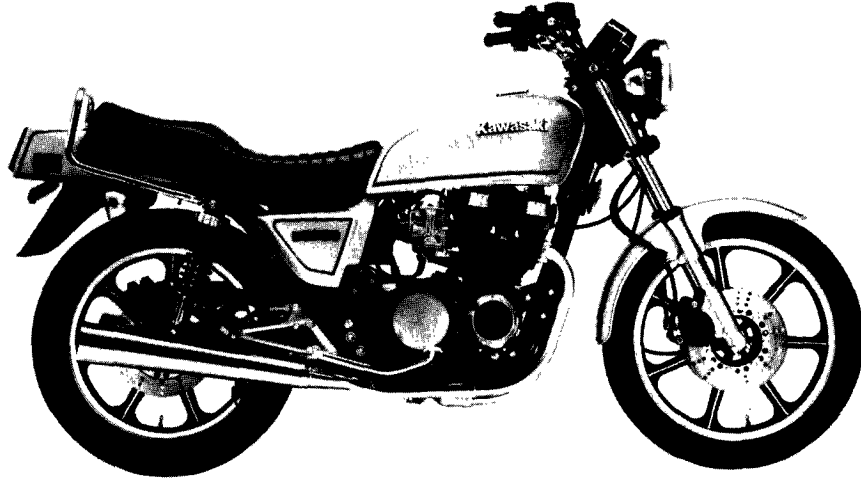

KZ750-H2

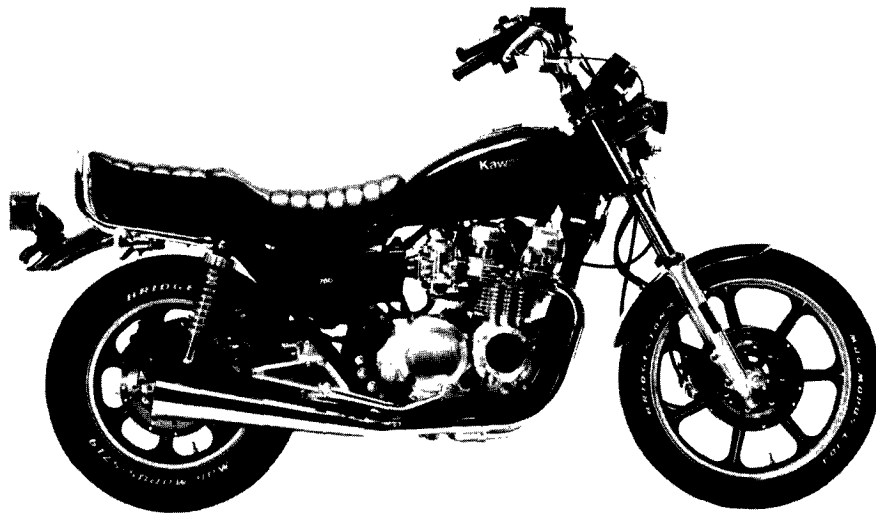

KZ750-L1

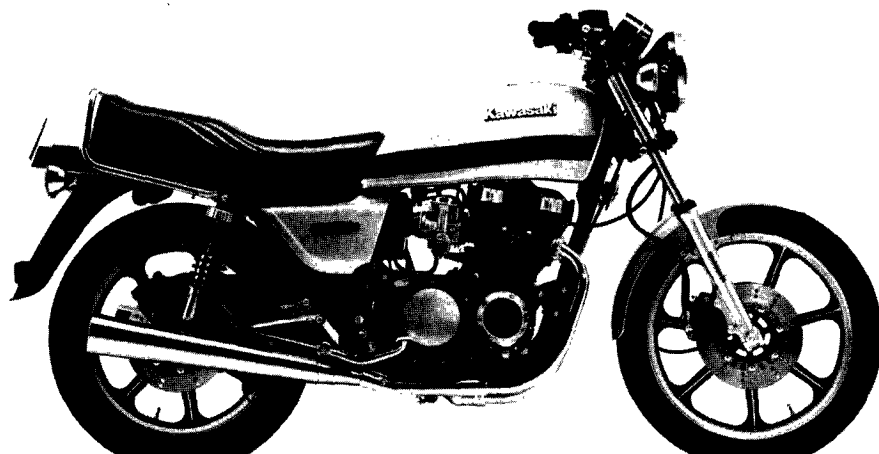

Specifications

SPECIFICATIONS

	KZ750-E2, L1	KZ750-H2
Dimensions		
Overall length	2,130 mm (A) (E) 2,190 mm	2,195 mm
Overall width	835 mm (A) (E) (S) 780 mm	810 mm
Overall height	1,135 mm	1,235 mm
Wheelbase	1,420 mm	1,450 mm
Road clearance	150 mm	155 mm
Dry weight	KZ750-E2: 210 kg KZ750-L1: 211 kg	211.3 kg
Fuel tank capacity	KZ750-E2: 17.3 ℓ KZ750-L1: 21.7 ℓ	12.4 ℓ
Performance		
Climbing ability	30°	*
Braking distance	12.5 m from 50 kph	*
Minimum turning radius	2.4 m	2.5 m
Engine		
Type	DOHC 4 cylinder, 4 stroke, air-cooled	*
Bore and stroke	66.0 x 54.0 mm	*
Displacement	738 cc	*
Compression ratio	9.0	*
Maximum horsepower	74 HP @9,000 rpm (W) 77 HP @9,500 rpm	74 HP @9,000 rpm
Maximum torque	6.4 kg-m @7,500 rpm	*
Valve timing		
Inlet	Open 30° BTDC	*
	Close 60° ABDC	*
	Duration 270°	*
Exhaust	Open 60° BBDC	*
	Close 30° ATDC	*
	Duration 270°	*
Carburetors	Keihin CV34 x 4	*
Lubrication system	Forced lubrication (wet sump)	*
Engine Oil	Type SE class SAE 10W40, 10W50, 20W40, or 20W50	*
	Capacity 3.5 ℓ	*
Starting system	Electric starter	*
Ignition system	Battery and coil (transistorized ignition)	*
Cylinder numbering method	Left to right, 1-2-3-4	*
Firing order	1-2-4-3	*
Ignition timing	From 10° BTDC @1,050 rpm	*
(Mechanically advanced)	to 40° BTDC @3,650 rpm	
Spark plugs	NGK B8ES or ND W24ES-U (C) (E) NGK BR8ES or ND W24ESR-U	*
Transmission		
Transmission type	5-speed, constant mesh, return shift	*
Clutch type	Wet, multi disc	*
Driving system	Chain drive	*
Gear ratio: 1st	2.33 (35/15)	*

		KZ750-E2, L1	KZ750-H2
Gear ratio:	3rd	1.27 (28/22)	*
	4th	1.04 (26/25)	*
	5th	0.88 (21/24)	*
	Primary reduction ratio	2.55 (27/23 x 63/29)	*
	Final reduction ratio	2.54 (33/13)	2.46 (32/13)
Overall drive ratio		5.66 @top gear	5.49 @top gear
Electrical Equipment			
Maximum alternator output		238 VA @10,000 rpm	*
Battery		Furukawa FB12A-A (12V 12AH)	*
Headlight	Type	Semi-sealed	*
	Bulb	12V 60/55W	*
Tail/Brake light(s)		(quartz halogen light) 12V 8/27W (A) (E) 12V 5/21W	12V 8/27W (E) 12V 5/21W
City light		12V 4W	*
Turn signal lights		12V 23W (E) 12V 21W	*
Turn signal/running position lights		12V 23/8W	*
Frame			
Type		Tubular, double cradle	*
Steering angle		39° to either side	*
Castor		27°	30°
Trail		108 mm	121 mm
Tire	Front	3.25H-19 4PR Tubeless	*
	Rear	4.00H-18 4PR Tubeless	130/90-16 67H Tubeless
Suspension type	Front	Telescopic fork	*
	Rear	Swing arm	*
Wheel travel	Front	160 mm	180 mm
	Rear	95 mm	*
Front fork oil	Type	SAE 10W	*
	Capacity (each fork)	232 cc (C) (U) 248 cc	280 cc
Brakes			
Type	Front	Dual disc brakes	*
	Rear	Single disc brake	*
Effective disc diameter	Front	226 mm	*
	Rear	226 mm	*

* : Same as left column

(A) : Australian model

(C) : Canadian model

(E) : European model

(S) : South African model

(U) : US model

(W) : West German model

Specifications subject to change without notice, and may not apply to every country.

272 SUPPLEMENT—1981 MODEL

PERIODIC MAINTENANCE CHART

The maintenance and adjustments for 1981 model must be done in accordance with this chart to keep the motorcycle in good running condition. The initial maintenance is vitally important and must not be neglected.

OPERATION	FREQUENCY	ODOMETER READING* km							See Page
		800 km	5,000 km	10,000 km	15,000 km	20,000 km	25,000 km	30,000 km	
Battery electrolyte level – check †	Every month	•	•	•	•	•	•	•	218
Brake – check †		•	•	•	•	•	•	•	24
Brake light switch – check †		•	•	•	•	•	•	•	25
Brake wear – check †			•	•	•	•	•	•	203
Brake fluid level – check †	month	•	•	•	•	•	•	•	207
Brake fluid – change	year			•		•		•	206
Clutch – adjust		•	•	•	•	•	•	•	17
Carburetor operation – check †		•	•	•	•	•	•	•	15
Throttle grip – check †		•	•	•	•	•	•	•	14
Steering play – check †		•	•	•	•	•	•	•	26
Drive chain wear – check †			•	•	•	•	•	•	198
Front fork – clean			•	•	•	•	•	•	211
Nuts, bolts, fasteners – check †		•		•		•		•	35–39
Spark plug – clean and gap †		•	•	•	•	•	•	•	12
Valve clearance – check †		•	•	•	•	•	•	•	12
Air suction valve – check † (If applicable)			•	•	•	•	•	•	166
Air cleaner element – clean			•		•		•		148
Air cleaner element – replace	5 cleanings			•		•		•	148
Fuel system – clean				•		•		•	19
Tire tread wear – check †			•	•	•	•	•	•	193
Engine oil – change	year	•	•	•	•	•	•	•	18
Oil filter – replace		•		•		•		•	18
General lubrication – perform			•	•	•	•	•	•	29
Front fork oil – change				•		•		•	214
Timing advancer – lubricate				•		•		•	227
Swing arm – lubricate				•		•		•	276
Wheel bearing – lubricate	2 years					•			197
Speedometer gear – lubricate	2 years					•			197
Steering stem bearing – lubricate	2 years					•			209
Master cylinder cup and dust seal – replace	2 years								201
Caliper piston seal and dust seal – replace	2 years								204
Brake hose – replace	4 years								208
Fuel hose – replace	4 years								–
Drive chain – lubricate	Every 300 km								198
Drive chain slack – check †	Every 800 km								23

* For higher odometer readings, repeat at the frequency interval here.

Adjustment

REAR SHOCK ABSORBERS

The adjustment procedures are the same as those for the 1980 models with the following exception.

- There is a boss on each adjusting sleeve to adjust the spring tension with the screwdriver bit.

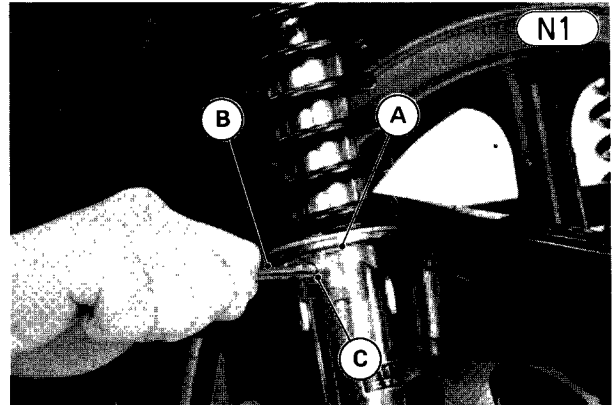

A. Adjusting Sleeve C. Boss
B. Screwdriver Bit

Disassembly

TORQUE

The table below shows the tightening torque for the part which is added to the list of the torque and locking agent (Pgs. 35~38).

Part	Quantity	Torque		See Pg.
		Metric (kg-m)	English (ft-lbs)	
Camshaft chain tensioner cap $\phi 18$ P1.5 (for the cross-wedge type)	1	2.5	18.0	274

FUEL TANK, FUEL LEVEL SENSOR

The fuel level sensor is attached to the bottom of the fuel tank on KZ750-E2 (also KZ750-L). The procedures of the removal and installation for the fuel tank and fuel level sensor are the same as those for the KZ750-H1. Refer to Pgs. 43~44.

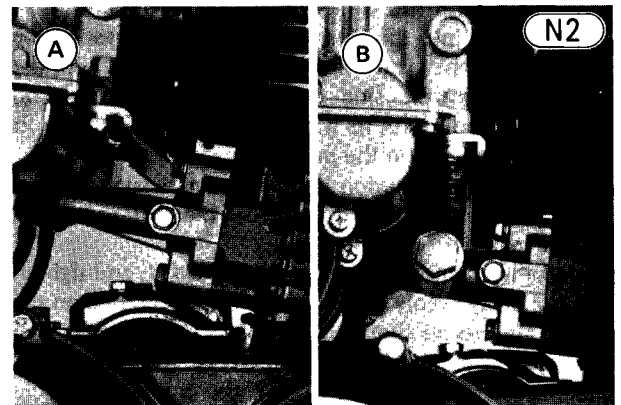

CAMSHAFT CHAIN TENSIONER

For the motorcycle which has the automatic camshaft chain tensioner of cross-wedge type, observe the

274 SUPPLEMENT—1981 MODEL

Removal:

- Remove the fuel tank (Pg. 43).
- Remove the carburetors (Pg. 45).
- Remove the chain tensioner cap and gasket, and remove the tensioner bolts (2) and tensioner.

Camshaft Chain Tensioner (Cross-wedge type)

N3

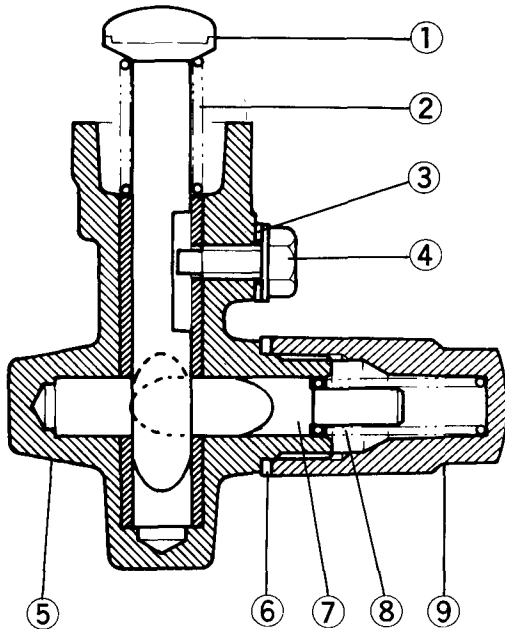

- | | |
|-------------------|------------------|
| 1. Push Rod | 6. Gasket |
| 2. Spring | 7. Push Rod Stop |
| 3. Washer | 8. Spring |
| 4. Bolt | 9. Tensioner Cap |
| 5. Tensioner Body | |

Installation:

- Remove the bolt and washer, and remove the push rod and spring from the tensioner body.
- Clean the tensioner parts using a high flash-point solvent, and then apply a molybdenum disulfide engine assembly grease to the sliding surfaces of them.

CAUTION The dirt or grime on the sliding surfaces of the tensioner parts could cause the tensioner malfunction.

- Install the push rod spring on the push rod and insert the push rod into the tensioner body. Compressing the spring, align the groove in the side of the rod with the screw hole in the side of the tensioner body, and tighten the bolt with its washer so that the foot of bolt inserts the groove on the push rod.

CAUTION Installation of the chain tensioner without the bolt can cause the push rod to fall into the cylinder.

- Install the chain tensioner body and gasket, and tighten the bolts (2) evenly. The upper bolt is longer than the lower, and has an aluminum washer.
- Check that either the #1 and #4, or the #2 and #3 pistons are at TDC. If not, turn the crankshaft clockwise and align one of the "T" marks on the timing

- If the cylinder head cover are removed, install it completely before doing the next steps.
- Install the chain tensioner push rod stop so that the tapered surfaces of the push rod and stop face each other. When the push rod stop has been properly installed, the push rod stop end sticks out about 10 mm.

NOTE: If the push rod stop sticks out over the correct amount, it shows the camshaft chain slack has not yet been taken up fully. In this case, turn the crankshaft over slowly in the normal direction pushing in the stop end lightly.

Push Rod Stop Installation

N4

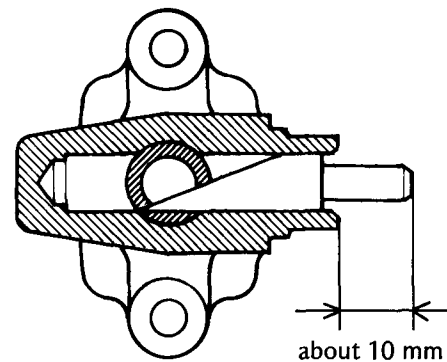

- Tighten the tensioner cap with its gasket to 2.5 kg-m (18.0 ft-lbs) of torque.
- Install the carburetors (Pg. 46).
- Install the fuel tank (Pg. 43).

REAR SHOCK ABSORBERS

Because the grab rail on KZ750-E (also KZ750-L) is changed, observe the following procedures before removing the rear shock absorbers.

- Remove the grab rail mounting bolts and nuts (2 ea), and remove the rear shock absorber upper mounting cap nuts, lockwashers, and flat washers (2 ea).

N5

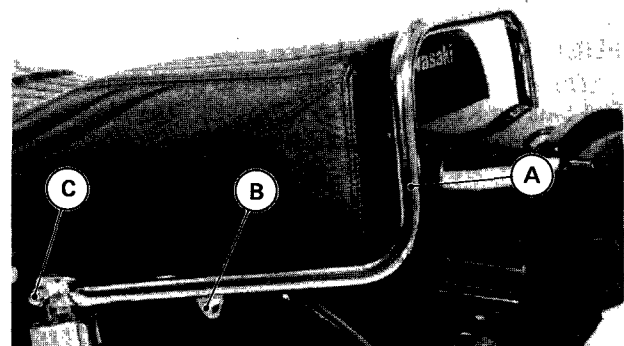

A. Grab Rail
B. Mounting Bolt

C. Cap Nut

Maintenance

CAMSHAFT CHAIN TENSIONER

For the motorcycle which has the automatic camshaft chain tensioner of cross-wedge type, observe the following notes referring to the procedures on Pgs. 159~160.

Cross-wedge Type Tensioner

The cross-wedge type tensioner consists of push rod ①, push rod stop ⑦, springs ②, ⑧, tensioner cap ⑨, tensioner body ⑤, and bolt ④. The push rod and push rod stop have a wedge-shaped portion, and are crossed wedgewise.

When the slack appears on the chain, the push rod is pushed out to the chain by the springs ②, ⑧, and it cannot be pushed back in because of the wedge-shaped portion of the push rod locking on the wedge-shaped portion of the push rod stop.

The bolt ④ is used to keep the push rod from falling into the crankcase.

Camshaft Chain Tensioner (Cross-wedge Type) (N6)

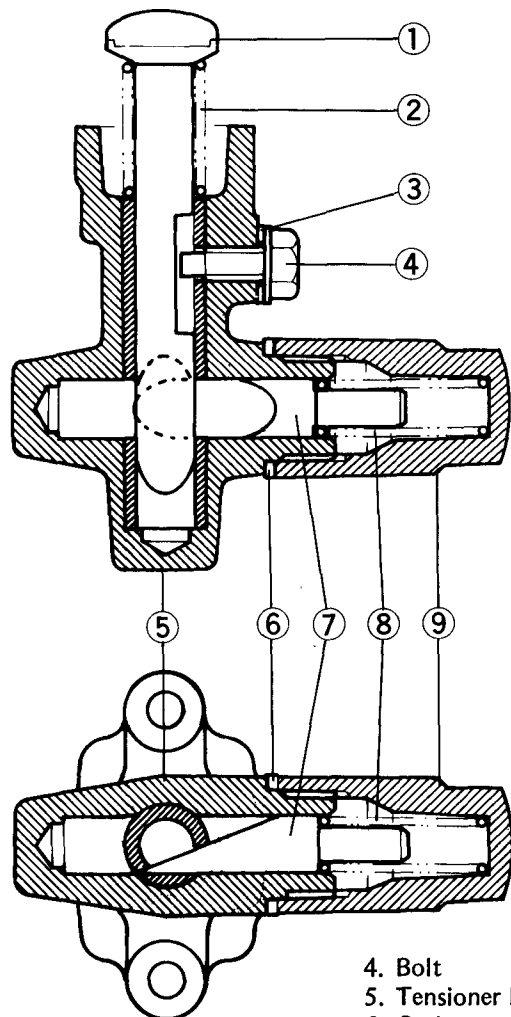

- 1. Push Rod
- 2. Spring
- 4. Bolt
- 5. Tensioner Body
- 6. Gasket
- 7. Push Rod Stop
- 8. Spring

Chain tensioner inspection

Visually inspect the push rod, push rod stop, and springs. If there is any damage or dent, replace the part with a new one.

Measure the free length of the springs. If they are shorter than the service limit, replace them with new ones.

Table N1 Chain Tensioner Spring Free Length

	Service Limit
Spring at push rod	36 mm
Spring at push rod stop	44 mm

CYLINDER HEAD, VALVE

Valve seat cutters (special tools) are newly available to repair the valve seat. See the exceptions in Pgs. 279~280 to inspection and repair the valve seat.

WHEEL

Tires on KZ750-H2 US and Canadian models are shown in the table below.

CAUTION These tires have the white letters on the side walls. When handling the white letter tire, observe the following to avoid contamination of the white letters.

1. Keep the tire wrapped until required for assembly to the rim.
2. Avoid the white letters on one tire touching the black rubber (tread, bead, etc.) on another.
3. Use only soap and/or water to clean the white letters. Do not use gasoline or chemical solvents.

Refer to Pgs. 192~197 for other service information not specifically mentioned here.

Table N2 Standard Tire (KZ750-H2 US and Canadian models)

	Size	Make, Type
Front	3.25H-19 4PR	BRIDGESTONE, Mag. Mopus-L303AW, Tubeless
Rear	130/90-16 67H	BRIDGESTONE, Mag. Mopus-S714W, Tubeless

SWING ARM

Because the grease nipple is deleted from the swing arm, the swing arm should be removed for its lubricating. Refer to Pgs. 214~216 for other service information.

Swing arm lubrication

In order for the swing arm to function safely and wear slowly, it should be properly lubricated in accordance with the Periodic Maintenance Chart (Pg. 272). Lubrication is also necessary after disassembly.

Remove the swing arm (Pg. 143), clean out the old grease, and apply grease to the needle bearings.

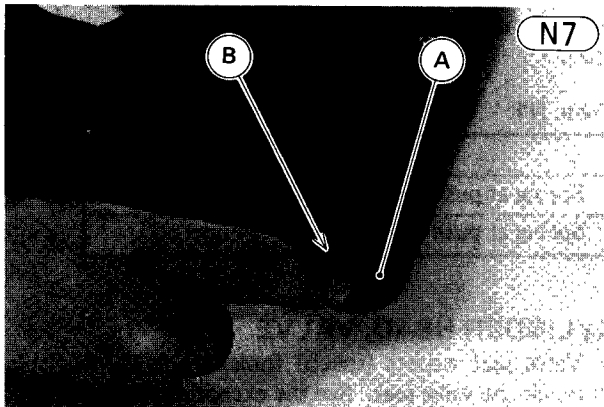

A. Needle Bearing B. Grease.

LIGHTING SYSTEM

Refer to Pgs. 239~247, noting the following:

1. The motorcycle on KZ750-E2 US and Canadian model contains a reserve lighting system in the headlight circuit. Refer to the procedures for KZ750-H to check the reserve lighting system.

2. The motorcycle on KZ750-H2 contains a automatic turn signal cancelling system. The procedures for inspection and repair are shown below.

Automatic Turn Signal Cancelling System

When the turn signal selector switch is in the A (Automatic) position, a solenoid turns off the turn signal after it has been on for 4 seconds, and from that time the motorcycle has traveled an additional 50 meters.

The cancelling system consists of the battery (power source), turn signal control unit, distance sensor, solenoid, and turn signal switch. When the turn signal switch is pushed to the left or right, the turn signals start flashing and the control unit starts counting off 4 seconds. At the end of this time, the control unit starts calculating distance traveled using pulses from the distance sensor in the speedometer. When the motorcycle has traveled 50 meters, the control unit operates the solenoid, which returns the turn signal switch to the off position.

If the turn signal cancelling system does not function properly, first check all the wiring connections carefully, and then inspect the distance sensor and turn signal switch/solenoid assembly. If all these are good, replace the turn signal control unit.

Distance sensor inspection

- Open the headlight housing, disconnect the 4-pin connector from the speedometer, and remove the speedometer cable lower end from the speedometer gear housing using pliers.
- Connect an ohmmeter across to the sensor lead (red and light green leads), and check continuity as follows.

Turn Signal Cancelling System

N8

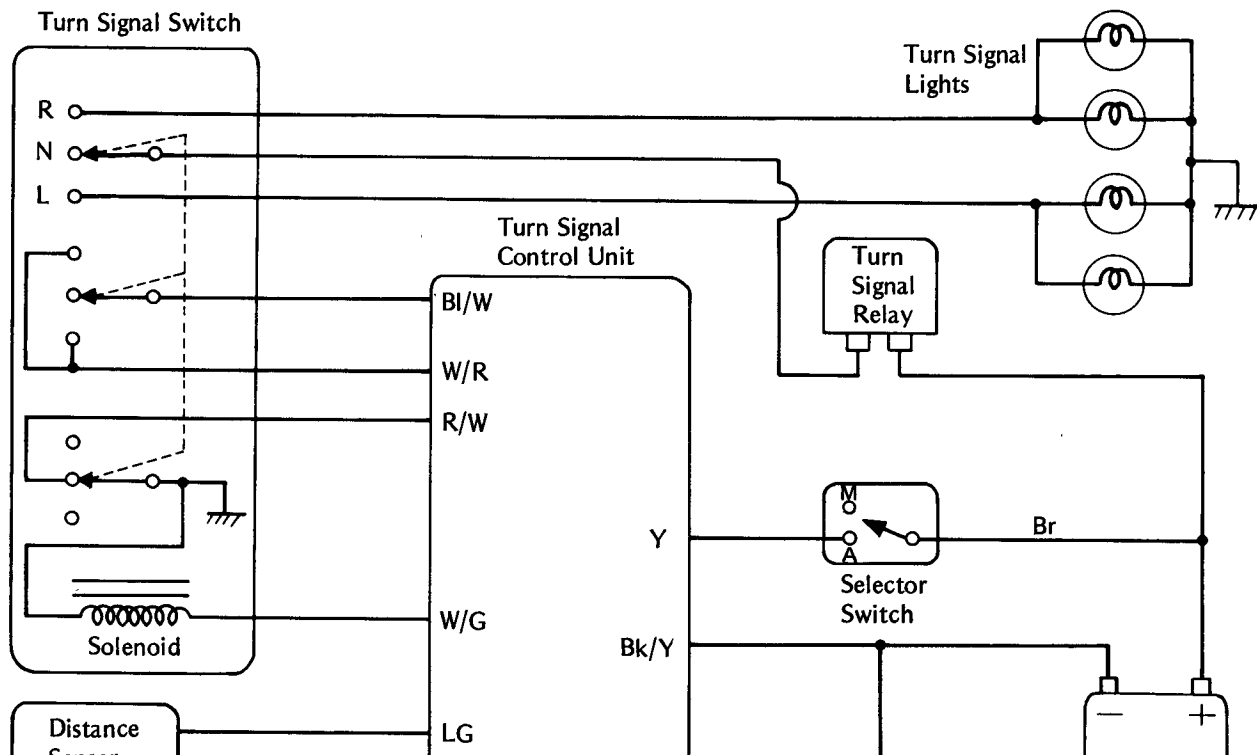

Turning the speedometer inner cable slowly, count how many times the sensor shows continuity. The ohmmeter should show continuity and then open four times per revolution. If it does not, replace the speedometer.

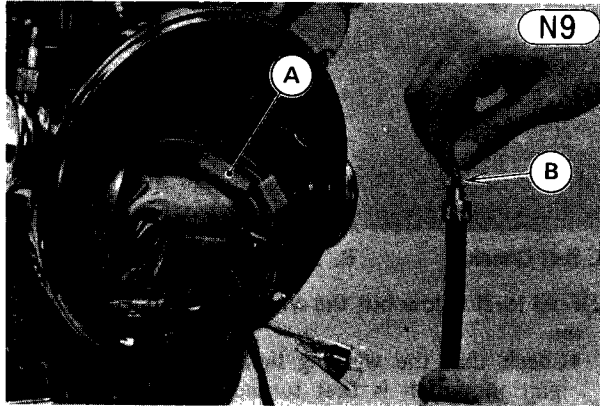

A. 4-pin Connector from the Speedometer
B. Turn the speedometer inner cable.

Turn signal and selector switch inspection

First remove the fuel tank, and unplug the 9-pin connectors and/or red/white lead from the left switch housing, check the turn signal switch and selector switch connections according to Table N3 and N4. If the switch has an open circuit or a short, it can be disassembled for repair. The contact surfaces may be cleaned, but no internal parts are available for replacement. If any parts are not repairable, the switch must be replaced as a unit.

Table N3 Selector Switch Connections

	Gray	Orange/Green	Green	Brown	Yellow
Δ	●————●————●				
M					
A				●————●	

Table N4 Turn Signal Switch Connections

	Gray	Orange	Green	Red/White	Ground	White/Red	Blue/White
R	●————●						●————●
N				●————●			
L		●————●					●————●

Table N5 Wiring Inspection

Meter Range	Connections*	Ignition Switch	Selector Switch Position	Turn Signal Switch Position	Reading
25V DC	Meter (+) → Yellow, Blue/White	ON	A	Any (R, L, Neu.)	Battery voltage
		OFF	M	Any	0 V
	Meter (+) → White/Red	ON	A	R or L	Battery voltage
		OFF	M	Neutral	0 V

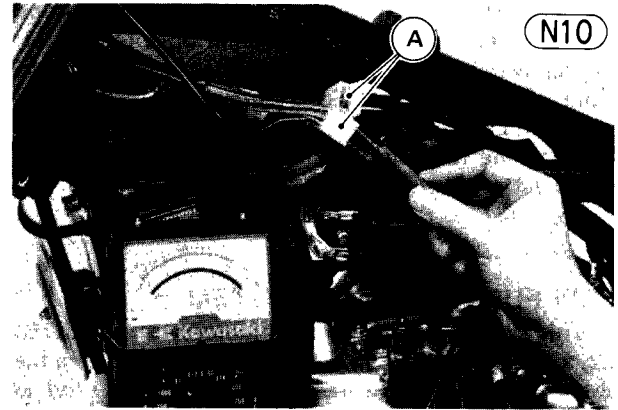

A. 9-pin Connectors for the Left Switch Housing

Next check that the solenoid operates properly when it receives a pulse from the control unit.

- Switch the turn signal switch to either side, connect a lead to the positive (+) side of the battery and touch its other end to the white/green lead momentarily. At this time the solenoid should return the turn signal switch to the off position. If it does not do this for both right and left positions, replace the switch assembly.

CAUTION Do not connect the battery lead to the white/green lead for more than a few seconds, as it could burn out the solenoid.

Wiring inspection

- Connect all the connectors and/or lead.
- Poll off the right side cover.
- Measure the voltage at the 6-pin connector from the turn signal control unit as shown in Table N5.

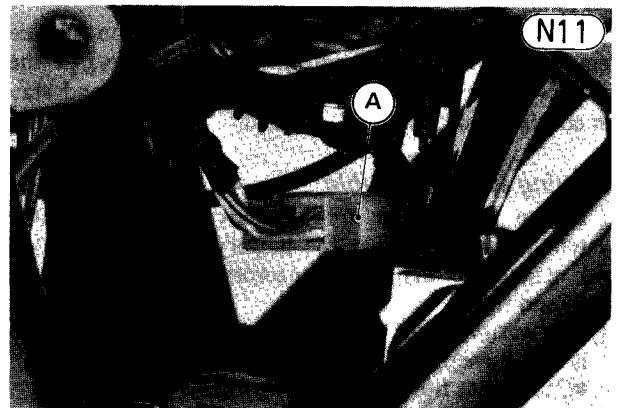

A. 6-pin Connector

278 SUPPLEMENT—1981 MODEL

●If any one of the meter readings shows an improper values, check the wiring and connections of the turn signal switch, distance sensor, and turn signal control unit. Replace the turn signal control unit if all of them turn out good.

NOTE: The turn signal control unit is located in front of the battery tray.

LOW FUEL WARNING SYSTEM

This system is added to the motorcycle on KZ750-E2, and also installed on KZ750-L1. It consists of a fuel level sensor inside the tank, a warning light, and an electronic self-checker to check the bulb.

Low Fuel Warning Circuit

(N12)

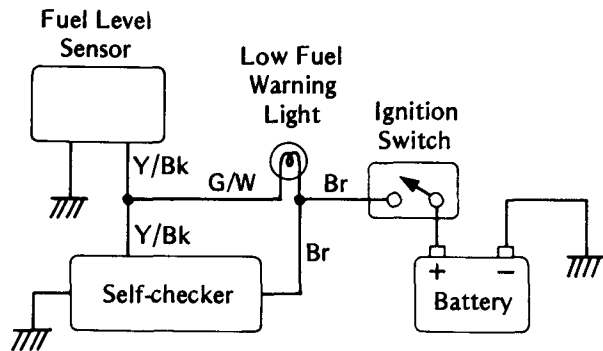

When the ignition switch is first turned on the warning light comes on immediately and then goes off after about 3 seconds. This is done by the self-checker to show that the bulb is not burned out, and the light will come on and go off regardless of the amount of fuel in the tank.

Then after about 3 minutes (depending on outside temperature and the condition of the battery), if the fuel level is low the light will come back on and stay on continuously until fuel is added.

Warning system trouble

Before starting to troubleshoot the fuel warning system, first check that the battery is good (Pg. 218) and make sure that all connectors in the system are clean and tight.

(1)The warning light does not come on when the switch is first turned on.

- Check that the bulb itself is good.
- Remove the right side cover and disconnect the 3-pin connector for the self-checker.
- Using the 20V DC or higher range of the meter, connect the (+) meter lead to the brown lead and the (-) meter lead to the black/yellow lead of the connector.
- Turn the ignition switch on (without starting the engine) and see if the meter reads battery voltage. If it does not, the wiring is at fault.
- If the meter does read battery voltage, plug the connector back in securely and check again whether the light comes on. If it still does not, the self-

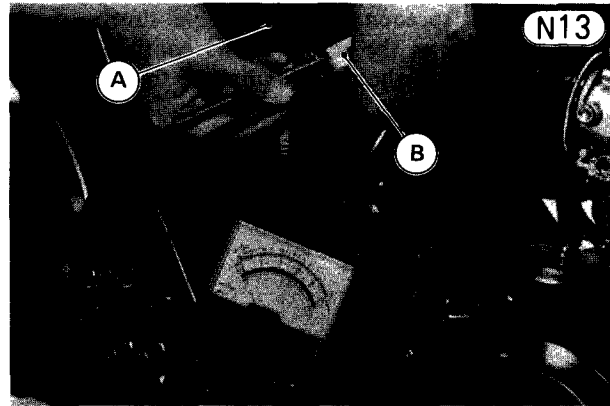

A. Self-Checker

B. 3-pin Connector

(2)Fuel level is low but the warning light does not come on.

- Check that the warning light comes on when the ignition switch is first turned on (See Problem 1 above).
- Disconnect the 2-pin connector to the fuel level sensor, set the meter to the 20V DC or higher range, and connect the (+) meter lead to the green/white lead and the (-) lead to the black/yellow lead.

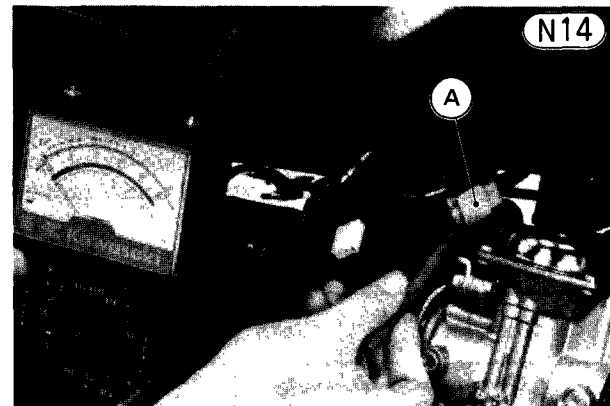

A. 2-pin Connector

- Turn on the ignition switch and read the meter. If it does not read battery voltage the wiring is at fault.
- If the meter does read battery voltage, the sensor is defective.

(3)Fuel level is not low but the warning light stays on continuously.

- Remove the right side cover, and disconnect the 3-pin connector to the self-checker.
- Now turn on the ignition switch. If the light still comes on, the sensor is bad. If the light stays off now, the self-checker is bad and must be replaced.

(4)Warning light goes on and off irregularly.

- Check that the fuel is well above the low level.
- Check that the wiring is not shorting out against other parts.
- Check that the battery charging voltage is normal (Pg. 223).
- If all the above checks are good, unplug the self-checker. If the problem disappears, the self-checker is bad and must be replaced. If the problem persists, recheck the wiring and check that the sensor

Appendix

SPECIAL TOOLS

1. The following special tools are newly available now.
 - (a) The valve seat cutters which can be used for all 4-stroke engines are manufactured by electrically nickelplating diamond particles on to the cutter body and can grind the valve seat in constant quality, which assures smooth finish of the seat surface.
 - (b) There are selections of inner and outer drivers to choose in the bearing driver set (P/N: 57001-1129), which can be used to press in the bearings on the engine and chassis of all models. Also, this set can replace the older bearing drivers of the following part numbers.

57001-138	57001-139	57001-140
57001-282	57001-283	57001-284
57001-286	57001-287	57001-288
57001-289	57001-290	57001-293
57001-296	57001-298	57001-1053

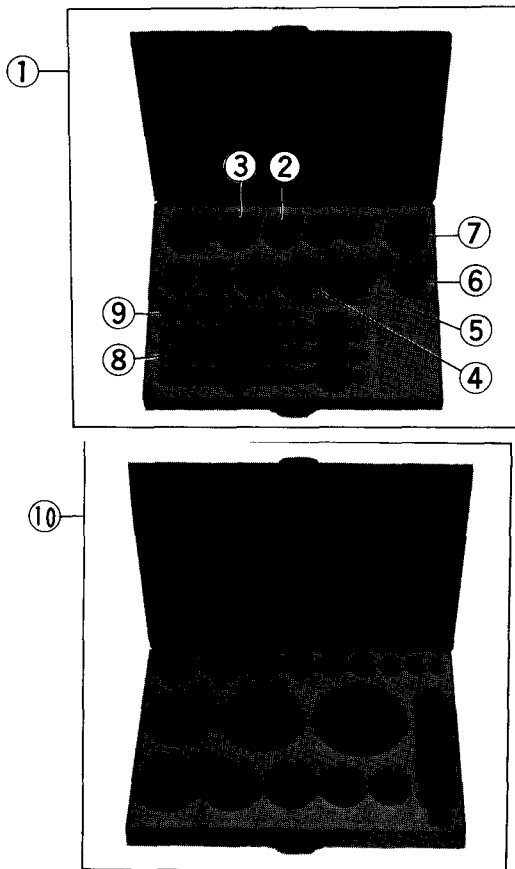

REF. NO.	PART NO.	DESCRIPTION
1	57001-1110	Valve Seat Cutter Set
2	57001-1115	Seat Cutter (#3)—Exhaust
3	57001-1116	Seat Cutter (#4)—Inlet
4	57001-1121	Outside Cutter (#9)—Exhaust
5	57001-1122	Outside Cutter (#10)—Inlet
6	57001-1123	Inside Cutter (#11)—Exhaust
7	57001-1124	Inside Cutter (#12)—Inlet
8	57001-1126	Cutter Holder ϕ 7.0 mm
9	57001-1128	Bar

2. When using the newly available valve seat cutters, the repair procedures are changed a little. See the following exceptions.

Valve seat inspection

The valve must seat in the valve seat evenly around the circumference over the specified area. If the seating area is too wide, the seating pressure per unit of area is reduced, which may result in compression leakage and carbon accumulation on the seating surface. If the seating area is too narrow, heat transfer from the valve is reduced and the valve will overheat and warp. Uneven seating, or seat damage will cause compression leakage.

- Remove the valve, and check to see if the valve and valve guide are in good condition before valve seat inspection.
- Apply machinist's dye to the valve seat, and then use a lapper to tap the valve lightly into place.
- Remove the valve, and note where the dye adheres to the valve seating surface. The distribution of seat condition (Fig. H47 in Pg. 164).
- ★ If the distribution of the dye shows uneven seating or seat damage, or if the seating area is out of the specified range repair the valve seat.

Table N6 Valve Seating Area

	Inlet	Exhaust
Outside Diameter	33 mm	29 mm
Width	0.5 ~ 1.0 mm	

Valve and Valve Seat

(N15)

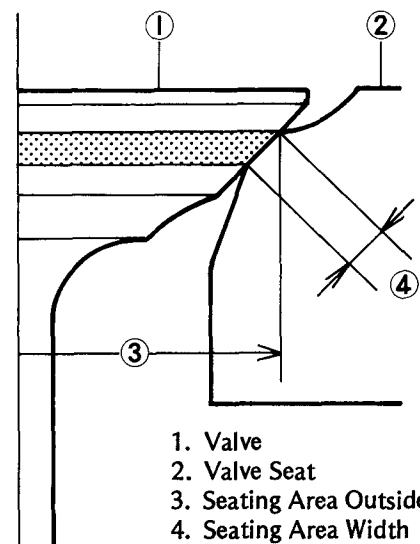

1. Valve
2. Valve Seat
3. Seating Area Outside Diameter
4. Seating Area Width

Valve seat repair

- First, cut the seating surface of the valve seat with the 45° seat cutter, cutter holder, and bar (special tools). Cut only the amount necessary to make a good surface; overcutting will reduce the valve clearance, possibly

280 SUPPLEMENT—1981 MODEL

NOTE: When using the cutter, be sure to apply engine oil to the cutting part before grinding and also wipe off ground particles adhering to the cutter with washing oil.

Valve Seat Cutter

(N16)

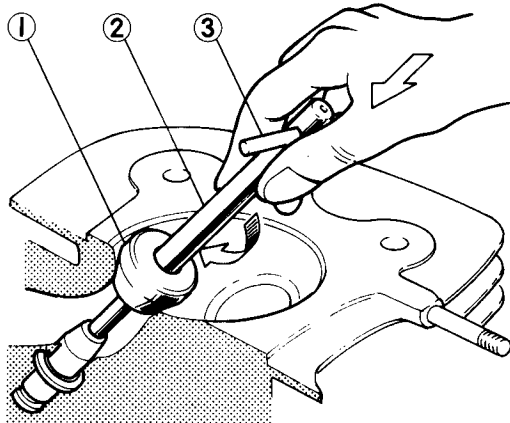

1. Cutter
2. Cutter Holder (7.0 mm): 57001-1126
3. Bar (57001-1128)

- Next, cut the outermost surface with the outside cutter (special tool) so that the valve seating surface will have the specified outside diameter.
- Then, cut the surface inside the seating surface with the inside cutter (special tool) so that the seating surface will have the specified width.

After cutting, lap the valve to properly match the valve and valve seat surfaces. Start off with coarse lapping compound, and finish with fine compound.

- Apply compound to the valve seat, and tap the valve lightly into place while rotating it with a lapper. Repeat this until a smooth, matched surface is obtained.
- When lapping is completed, check the valve installed height and adjust if necessary (Pg. 165).

Lapping Valve Seat

(N17)

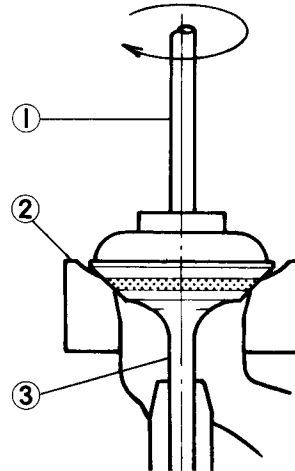

1. Lapper
2. Valve Seat
3. Valve

WIRING DIAGRAMS

The following wiring diagrams are shown the KZ750-E2, H2, L1 wiring diagrams.

Cutting Valve Seat

(N18)

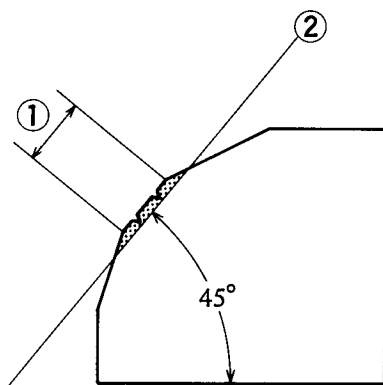

First Step:

1. Original seating surface
2. Cut seating surface with following seat cutters to obtain new seating surface.
 - Inlet: Seat Cutter (#4): 57001-1116
 - Exhaust: Seat Cutter (#3): 57001-1115

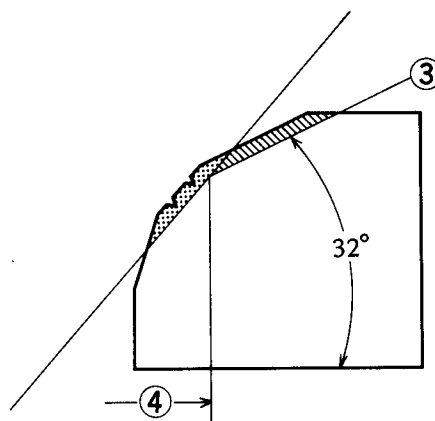

Second Step:

3. Cut the new seating surface to adjust outside diameter of new seating surface with following outside cutters.
 - Inlet: Outside Cutter (#10): 57001-1122
 - Exhaust: Outside Cutter (#9): 57001-1121

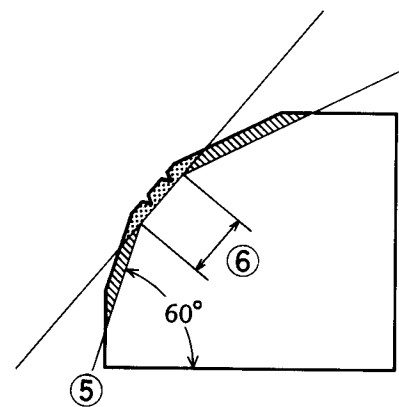

Third Step:

5. Cut the new surface obtain correct width with following inside cutters.
 - Inlet: Inside Cutter (#12): 57001-1124
 - Exhaust: Inside Cutter (#11): 57001-1123
6. Specified Width

Supplement for 1982 Model

Table of Contents

[ALL MODELS]

MODEL IDENTIFICATION	287
SPECIFICATIONS	
SPECIFICATIONS	288
PERIODIC MAINTENANCE CHART	290
ADJUSTMENT	
THROTTLE GRIP	291
CLUTCH	291
FUEL SYSTEM	291
REAR SHOCK ABSORBERS	291
DISASSEMBLY	
TORQUE AND LOCKING AGENT	294
AIR SUCTION VALVES (on US model)	295
CLUTCH RELEASE	295
STARTER MOTOR	295
TRANSMISSION	297
CONNECTING RODS	298
THROTTLE CABLE	298
SWING ARM	299
MAINTENANCE	
CARBURETORS (on US model)	310
CONNECTING RODS	310
TRANSMISSION	310
REAR SHOCK ABSORBERS	310
FRONT FORK	311
ELECTRIC STARTER SYSTEM	311
LIGHTING SYSTEM	312
APPENDIX	
SPECIAL TOOLS	328
WIRING DIAGRAMS	329

[KZ750H]

ADJUSTMENT	
WHEEL BALANCE (on KZ750H)	292
MAINTENANCE	
LOW FUEL WARNING SYSTEM (on KZ750H)	312

286 SUPPLEMENT—1982 MODEL

[KZ750R]

ADJUSTMENT

FRONT FORK (on KZ750R)	292
BRAKES (on KZ750R)	293
STEERING (on KZ750R)	293

DISASSEMBLY

FUEL LEVEL SENSOR (on KZ750R)	299
CARBURETORS (on KZ750R)	299
MUFFLERS (on KZ750R)	302
CAMSHAFTS (on KZ750R)	304
OIL PASSAGE PLUG (on KZ750R)	304
OIL COOLER (on KZ750R)	304
ENGINE REMOVAL (on KZ750R)	305
TURN SIGNAL ASSY (on KZ750R)	306
FRONT BRAKE LIGHT SWITCH (on KZ750R)	306
HANDLEBARS, HOLDERS (on KZ750R)	306
FRONT FORK (on KZ750R)	307
STEERING STEM, BEARINGS (on KZ750R)	309

MAINTENANCE

AIR CLEANER ELEMENT (on KZ750R)	312
CARBURETORS (on KZ750R)	312
CYLINDER HEAD (on KZ750R)	318
PISTON, PISTON RINGS (on KZ750R)	318
SPROCKETS (on KZ750R)	318
STEERING STEM (on KZ750R)	318
FRONT FORK (on KZ750R)	318
TACHO/VOLTMETER (on KZ750R)	319
LCD FUEL GAUGE AND WARNER UNIT (on KZ750R)	323

APPENDIX

ADDITIONAL CONSIDERATIONS FOR RACING (on KZ750R)	328
---	-----

NOTE: The service informations for the 1982 KZ/Z750R are newly included in this section. Unless otherwise noted, refer to the following 1981 model.

KZ750-E2/Z750-L1 for KZ/Z750-R1

Model Identification

Z750-L2

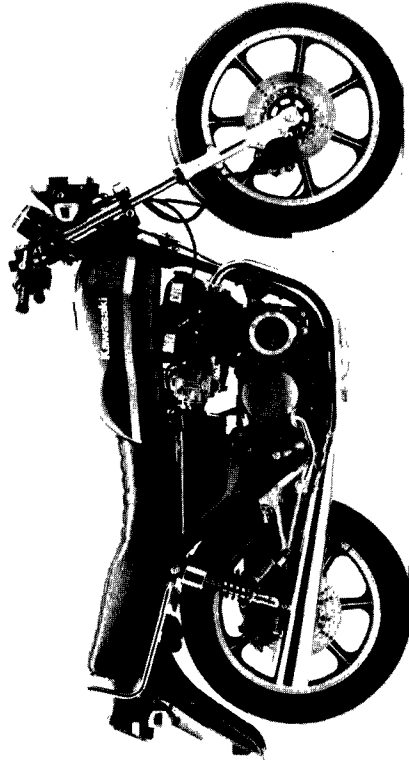

KZ750-R1

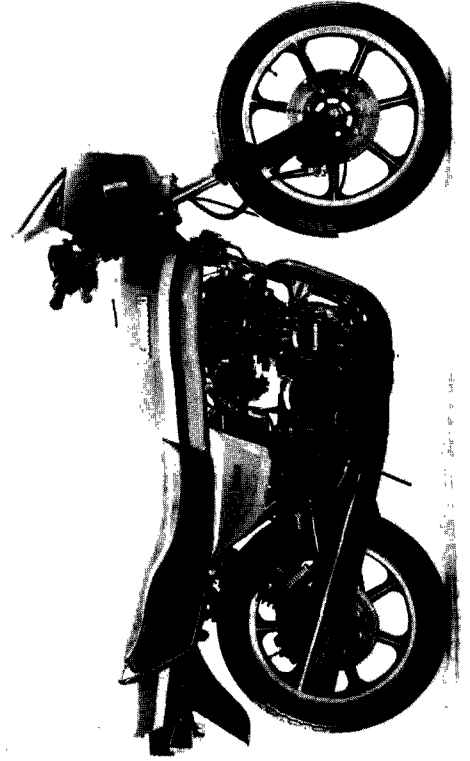

750-E3

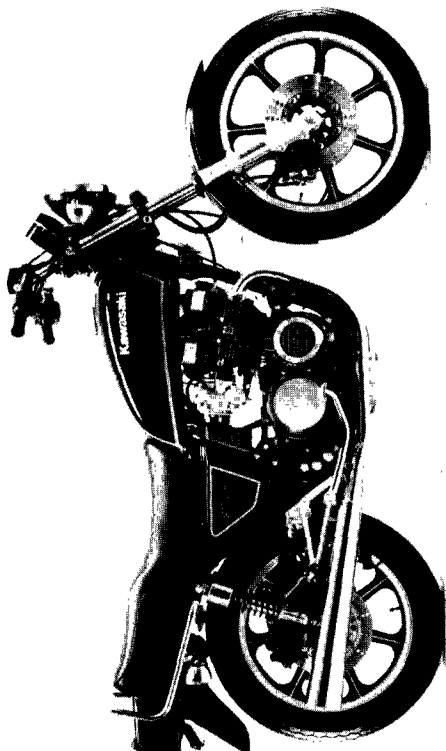

750-H3

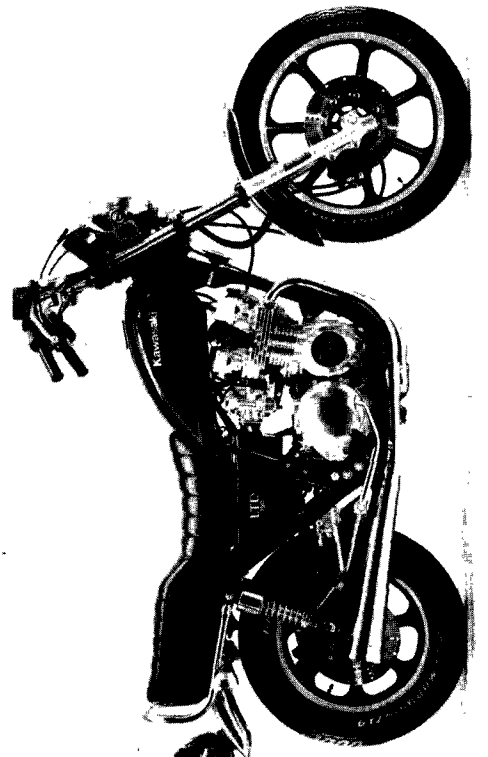

Specifications

SPECIFICATIONS

Items	KZ750-E3, Z750-L2	KZ750-H3	KZ750-R1
Dimensions:			
Overall length	2,130 mm, (A) (E) 2,190 mm	2,195 mm, (A) (E) 2,210 mm	2,170 mm, (A) (E) 2,215 mm
Overall width	835 mm, (A) (E) (S) 780 mm	810 mm	780 mm
Overall height	1,135 mm	1,235 mm	1,220 mm
Wheelbase	1,420 mm	1,450 mm	1,460 mm
Road Clearance	150 mm	155 mm	140 mm
Seat height	790 mm, (E) 810 mm	770 mm	800 mm
Dry weight	KZ750E: 210 kg Z750L: 211 kg	211.3 kg	217 kg
Fuel tank capacity	KZ750E: 17.3 ℓ Z750L: 21.7 ℓ	12.4 ℓ	21.7 ℓ
Performance:			
Climbing ability	30°	*	*
Braking distance	12.5 m from 50 kph	*	*
Minimum turning radius	2.4 m	2.5 m	**
Engine:			
Type	DOHC, 4-cylinder, 4-stroke	*	*
Cooling system	Air-cooled	*	*
Bore and stroke	66.0 x 54.0 mm	*	*
Displacement	738 cc	*	*
Compression ratio	9.0	*	9.5
Maximum horsepower	74 hp @9,000 rpm (W) 77 hp @9,500 rpm	74 hp @9,000 rpm	80 hp @9,500 rpm
Maximum torque	6.4 kg-m @7,500 rpm	*	6.7 kg-m @7,500 rpm
Valve timing:			
Inlet	Open 30° BTDC	*	*
	Close 60° ABDC	*	*
	Duration 270°	*	*
Exhaust	Open 60° BBDC	*	*
	Close 30° ATDC	*	*
	Duration 270°	*	*
Carburetion system	Carburetors, Keihin CV34	*	Carburetors, Mikuni BS34
Cylinder numbering method	Left to right, 1-2-3-4	*	*
Firing order	1-2-4-3	*	*
Lubrication system	Forced lubrication (wet sump)	*	Forced lubrication (wet sump with cooler)
Engine oil: Grade	SE class	*	*
Viscosity	SAE10W40, 10W50, 20W40, or 20W50	*	*
Capacity	3.5 ℓ	*	*
Starting system	Electric starter	*	*
Ignition system	Battery and coil (transistorized ignition)	*	*
Timing advance	Mechanically advanced	*	*
Ignition timing	From 10° BTDC @1,050 rpm to 40° BTDC @3,650 rpm	*	*
Spark plug	NGK B8ES or ND W24ES-U (C) (C) NGK BR8ES or	*	*

Specifications (Cont.):

Items	KZ750-E3, Z750-L2	KZ750-H3	KZ750-R1
Drive Train:			
Primary reduction system:			
Type	Chain and gear	*	*
Reduction ratio	2.550 (27/23 x 63/29)	*	*
Clutch type	Wet multi disc	*	*
Transmission: Type	5-speed, constant mesh, return shift	*	*
Gear ratios 1st	2.333 (35/15)	*	*
2nd	1.631 (31/19)	*	*
3rd	1.272 (28/22)	*	*
4th	1.040 (26/25)	*	*
5th	0.875 (21/24)	*	*
Final drive system:			
Type	Chain	*	*
Reduction ratio	2.538 (33/13)	2.461 (32/13)	*
Overall drive ratio	5.664 @top gear	5.492 @top gear	*
Frame:			
Type	Tubular, double cradle	*	*
Castor (rake angle)	27°	30°	*
Trail	108 mm	121 mm	107 mm
Front tire: Type	Tubeless	*	*
Size	3.25H-19 4PR	*	100/90 V-19, Ⓢ Ⓤ 100/90-19 57H
Rear tire: Type	Tubeless	*	*
Size	4.00H-18 4PR	130/90-16 67H	120/90V-18, Ⓢ Ⓤ 120/90-18 65H
Front suspension: Type	Telescopic fork (pneumatic)	*	*
Rear suspension: Type	Swing arm	*	*
Wheel travel	160 mm	180 mm	150 mm
Wheel travel	95 mm	*	111 mm
Brake type: Front	Dual disc brake	*	*
Rear	Single disc brake	*	*
Electrical Equipment:			
Alternator: Type	Three-phase AC	*	*
Rated output	17A @10,000 rpm, 14V	*	17A @8,000 rpm, 14V
Voltage regulator	Short-circuit type	*	*
Battery	12V 12AH	*	*
Headlight: Type	Semi-sealed	*	*
Bulb	12V 60/55W	*	*
Tail/brake light	12V 8/27W x2	*	*
	Ⓐ Ⓔ 12V 5/21W x 2	*	*

* : Same as KZ750-E3, L2
 ** : Same as KZ750-H3
 Ⓐ : Australian model
 Ⓒ : Canadian model
 Ⓔ : European model

Ⓢ : European model except Italian and Norwegian models
 Ⓢ : South African model
 Ⓤ : US model
 Ⓦ : West German model

290 SUPPLEMENT—1982 MODEL

PERIODIC MAINTENANCE CHART

The maintenance and adjustments for 1982 model must be done in accordance with this chart to keep the motorcycle in good running condition. The initial maintenance is vitally important and must not be neglected.

OPERATION	FREQUENCY	ODOMETER READING*							See Page	
		Whichever comes first ↓	800 km	5,000 km	10,000 km	15,000 km	20,000 km	25,000 km		30,000 km
Engine oil — change	Every year	•	•	•	•	•	•	•	•	18
Oil filter — replace		•		•		•		•		18
Fuel system— clean				•		•		•		19,291
Fuel hose — replace	4 years									—
Spark plug — clean and gap †		•	•	•	•	•	•	•	•	12
Timing advancer — lubricate				•		•		•		227
Valve clearance — check †		•	•	•	•	•	•	•	•	12
Air suction valve — check † (only on US model)			•	•	•	•	•	•	•	166
Air cleaner element — clean			•		•		•			148,312
Air cleaner element — replace	5 cleanings			•		•		•		148,312
Throttle grip — check †		•	•	•	•	•	•	•	•	291
Idle speed — check †		•	•	•	•	•	•	•	•	15
Carburetor synchronization — check †		•	•	•	•	•	•	•	•	15
Clutch — adjust		•	•	•	•	•	•	•	•	17,291
Drive chain wear — check †			•	•	•	•	•	•	•	198
Drive chain — lubricate	300 km									198
Drive chain slack — check †	800 km									23
Brake lining wear — check †			•	•	•	•	•	•	•	203
Brake fluid level — check †	month	•	•	•	•	•	•	•	•	207
Brake fluid — change	year			•		•		•		206
Brake hose — replace	4 years									208
Master cylinder cup and dust seal — replace	2 years									201
Caliper piston seal and dust seal — replace	2 years									204
Brake light switch — check †		•	•	•	•	•	•	•	•	25
Steering play — check †		•	•	•	•	•	•	•	•	26,293
Steering stem bearing — lubricate	2 years					•				209,318
Front fork oil — change				•		•		•		214,318
Front fork oil seal — clean			•	•	•	•	•	•	•	211
Tire wear — check †			•	•	•	•	•	•	•	193
Wheel bearing — lubricate	2 years					•				197
Speedometer gear — lubricate	2 years					•				197
Swing arm pivot — lubricate				•		•		•		276
Battery electrolyte level — check † (Not on KZ750R)	month	•	•	•	•	•	•	•	•	218
General lubrication — perform			•	•	•	•	•	•	•	29
Nut, bolt, fastener tightness — check †		•		•		•		•		35

* : For higher odometer readings, repeat at the frequency interval established here.

Adjustment

THROTTLE GRIP

Inspection

- Turn the throttle grip back and forth to check the throttle grip play.

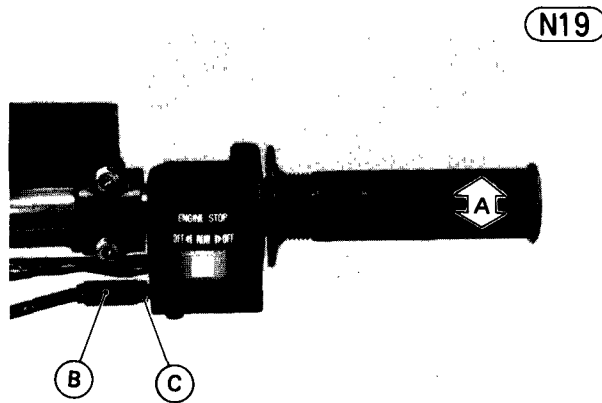

- A. 2 – 3 mm
- B. Adjusting Nut
- C. Locknut

★There should be 2 – 3 mm play measured at the grip. If the cable does not have the proper play, adjust it.

Adjustment

- Loosen the locknut at the upper end of the throttle cable, and turn the adjusting nut to adjust the play.
 - Tighten the locknut.
- NOTE:** For the motorcycles other than KZ750R, if the throttle grip cannot be adjusted by using the adjusting nut at the cable upper end, use the adjuster at the cable lower end. Do not forget to securely tighten the adjuster locknuts.

CLUTCH

The clutch release was modified as shown in Fig. N30. When adjusting the clutch, refer to Pgs. 17 – 18, noting the following.

To adjust the clutch release:

- Loosen the locknut, and turn the adjusting screw **counterclockwise** until it becomes hard to turn. This is the point where the clutch is just starting to release.
- Turn the adjusting screw **clockwise** ¼ turn from that point.
- Tighten the locknut without changing the screw

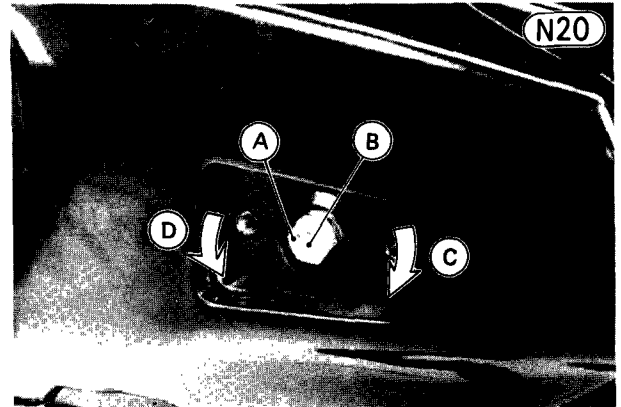

- A. Locknut
- B. Adjusting Screw
- C. Turn Clockwise.
- D. Turn Counterclockwise.

FUEL SYSTEM

The overflow tube on each carburetor float bowl was detached. So, before draining the carburetors, refer to Pg. 19, noting the following.

- Connect a suitable hose to the fitting at the bottom of each carburetor float bowl, and run the lower end of the hose into a suitable container.

REAR SHOCK ABSORBERS

Refer to Pgs. 22 – 23, noting the following.

1. The damper adjuster on each shock has **5** positions so that the damping force can be adjusted. The number on the damper adjuster show the setting positions of the damper.

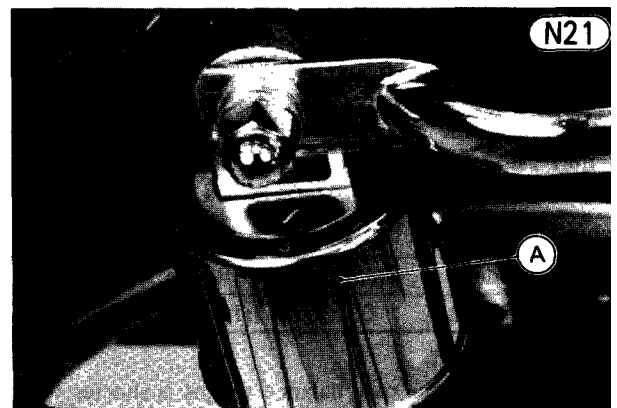

292 SUPPLEMENT—1982 MODEL

Table N7 Damping Force

Position	1	2	3	4	5
Damping Force	Larger \longrightarrow				

- For the rear shock absorbers on KZ750R, the spring adjusting sleeve on each shock has 7 positions so that the spring action can be adjusted.

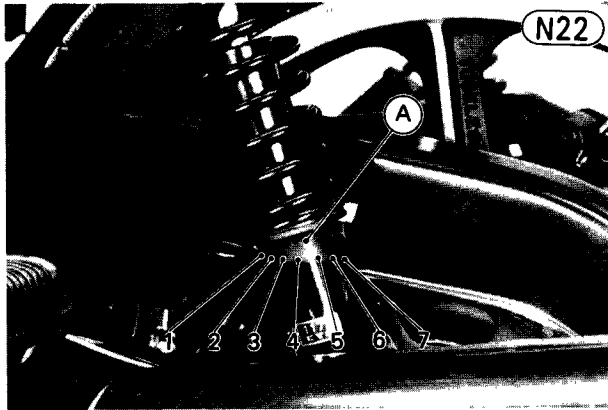

A. Spring Adjusting Sleeve

Table N8 Spring Action

Position	1	2	3	4	5	6	7
Spring Action	Stronger \longrightarrow						

WHEEL BALANCE (on KZ750H)

Refer to Pgs. 27 – 28, noting the following.

- For Bridgestone front tire on the KZ750H, new balance weights must be required to balance the wheel. If the old-style balance weights are used, it may cause to leak air.

Table N9 Eligible Units

Model	Frame Number Range
KZ750-H3	Q316Q1 – Q35911

- The blade of the new balance weight is shorter than the blade of the old-style balance weight, and are

Balance Weight

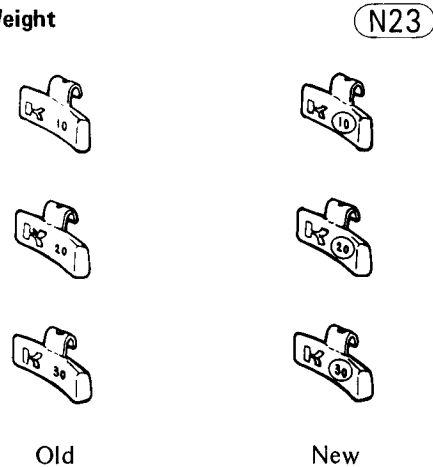

FRONT FORK (on KZ750R)

Refer to Pg. 22, noting the following.

- The front fork on KZ750R has the connecting hose assembly to equalize the air pressure between the left and right fork legs.
- The front fork on KZ750R has only one air valve at the right bracket of the connecting hose assembly to release and inject air.

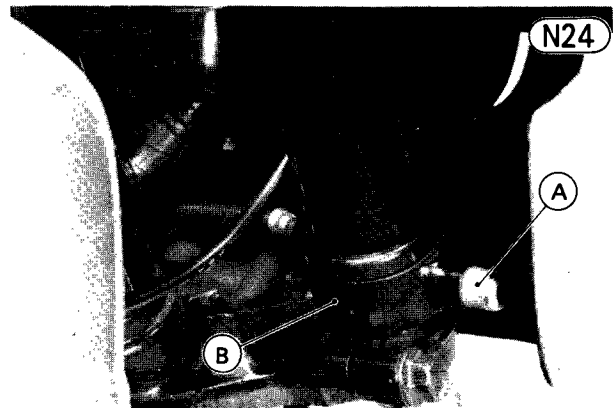

A. Air Valve B. Connecting Hose Bracket

- See the following table to adjust the KZ750R front fork air pressure.

Table N10 Front Fork Air Pressure

Standard:	0.7 kg/cm ² (70 kPa, 10.0 psi)
Usable Range:	0.6 – 0.9 kg/cm ²

BRAKES (on KZ750R)

Refer to Pgs. 24 – 25, noting the following.

Pedal Position Inspection

- When the brake pedal is in its rest position, it should be 14 – 18 mm lower than the top of the footpeg.

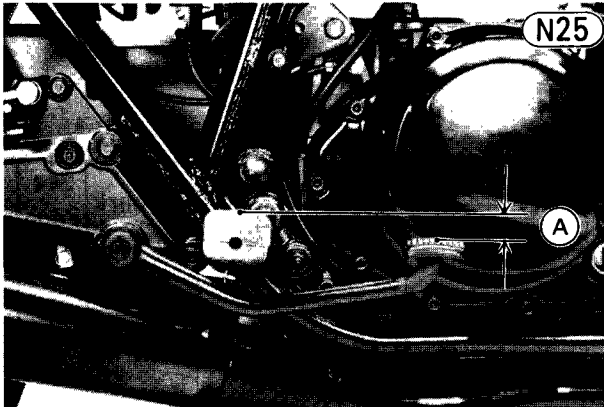

A. 14 – 18 mm

- ★If it is not within the specified range, adjust the brake pedal position.

STEERING (on KZ750R)

Steering Inspection

Refer to Pg. 26.

Steering Adjustment

Proper steering adjustment is completed by finding out the correct position of the lower stem locknut and by tightening the stem head bolt to the specified torque.

- Remove the fairing.
- Remove the fuel tank to avoid damaging the painted surface.
- Remove the screws, and take off the stem head cover.
- Loosen the front fork lower clamp bolts and stem head bolt.
- Set the motorcycle up on its center stand.
- Using a jack under the engine, lift the front wheel off the ground.
- Loosen the upper stem locknut all the way with the

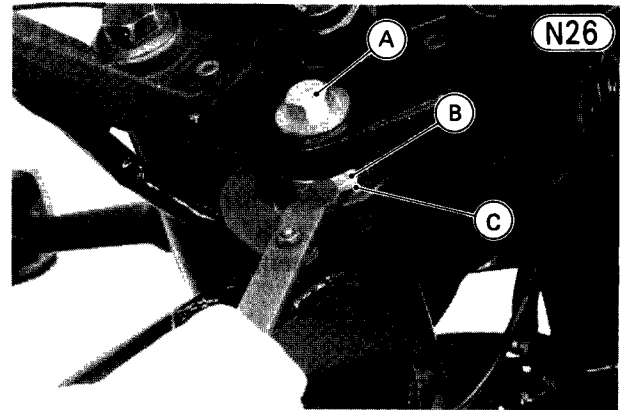

A. Stem Head Bolt B. Upper Stem Locknut
C. Lower Stem Locknut

NOTE: The following four steps should be performed on only first adjustment after steering bearing installation. This procedure settle the bearings in place.

- Using the stem nut wrench, tighten the lower stem locknut to 4.0 kg-m (39 N-m, 29 ft-lb) of torque. To tighten the steering stem locknut to the specified torque, hook the wrench on the stem locknut, and pull the wrench at the hole by 22.2 kg force in the direction.

Torquing Stem Locknut

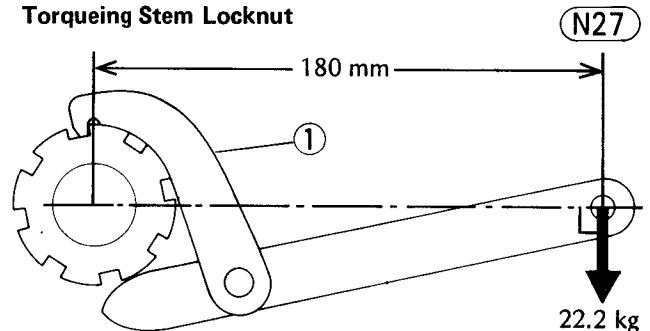

1. Stem Nut Wrench: 57001-1100

- Check that there is no play and the steering stem turns smoothly without the rattle. If not, the steering stem bearing may be damaged.
- Again back out the lower steering stem locknut a fraction of a turn until it turns lightly.
- Turn the lower steering stem locknut lightly clockwise until it just becomes hard to turn. Do not overtighten, or the steering will be too tight.
- If the steering is too tight, loosen the lower stem locknut a fraction of turn; if the steering is too loose, tighten the locknut a fraction of turn. Turn the locknut a 1/8 turn at maximum at a time.
- Keeping the lower stem locknut at the position with another wrench (Hook Wrench: 92110-1036), tighten the upper stem locknut lightly.
- Tighten the steering stem head bolt to 3.0 kg-m (29 N-m, 22 ft-lb) of torque.
- Tighten the front fork lower clamp bolts to 3.8 kg-m (37 N-m, 27 ft-lb) of torque.
- Check the steering again.
- ★If the steering is still too tight or too loose, repeat the adjustment.

Disassembly

TORQUE AND LOCKING AGENT

The table below shows the tightening torque for the parts which are added to the list of the torque and locking agent (Pgs. 35 – 38).

NOTE: Mark used in "Remark"

- : Apply a non-permanent locking agent to the threads.

Part	Dia. x Pitch (mm)	Q'ty	Torque			Remark	See Page
			kg-m	N-m	ft-lb		
Engine Parts							
Carburetor holder Allen Bolts (only on KZ750R)	6 x 1.0	8	1.4	14	10.0	•	299
† Engine mounting bolts (only on KZ750R)	10 x 1.25	4	4.0	39	29	—	306
† Engine mounting bracket bolts (only on KZ750R)	8 x 1.25	8	2.4	24	17.5	—	306
Oil passage plug (only on KZ750R)	PT 1/8	1	1.3	13	113 in-lb	•	304
Oil tube connecting nuts (only on KZ750R)	16 x 1.4	2	2.2	22	16.0	—	304
Chassis Parts							
Front fork air valve (only on KZ750R)	8 x 1.0	1	0.80	7.8	69 in-lb	•	309
† Handlebar clamp bolts (only on KZ750R)	8 x 1.25	2	3.0	29	22	—	307
† Handlebar holder bolts (only on KZ750R)	32 x 1.5	2	10.0	98	72	—	307
† Steering stem head bolt (only on KZ750R)	14 x 1.5	1	3.0	29	22	—	293
Electrical Equipment							
Front brake light switch mounting screw (only on KZ750R)	4 x 0.7	1	—	—	—	•	306
IC igniter mounting bolts (with insulation bushing)	6 x 1.0	2	0.65	6.4	56 in-lb	—	—
Starter motor end cover screws	6 x 1.0	2	0.55	5.4	48 in-lb	—	297
Starter motor terminal nut	6 x 1.0	1	1.1	11	95 in-lb	—	295
Turn signal mounting nuts (only on KZ750R)	10 x 1.25	4	1.3	13	113 in-lb	—	306

AIR SUCTION VALVES (on US Model)

The air suction valve assembly was modified and the gasket was added newly under the valve assembly. Refer to Pg. 52, noting the following.

- Replace the gasket with new one if it was removed, and install it between the valve housing on the cylinder head cover and the valve assembly.

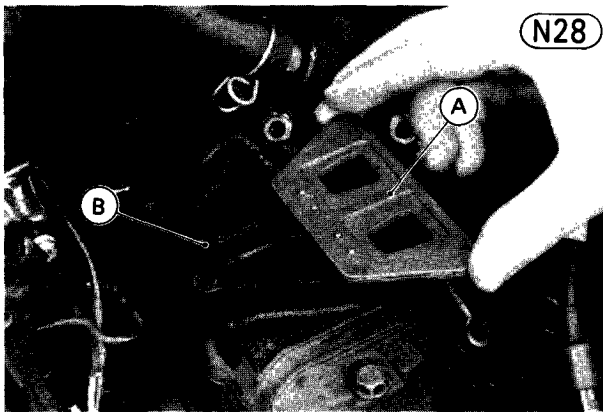

N28

A. Valve Assembly B. Gasket

Clutch Release

N30

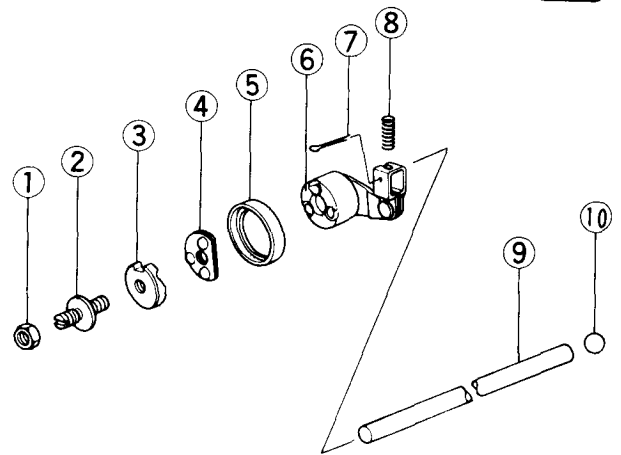

- | | |
|--------------------|------------------|
| 1. Locknut | 6. Release Lever |
| 2. Adjusting Screw | 7. Cotter Pin |
| 3. Ball Ramp Plate | 8. Spring |
| 4. Ball Assembly | 9. Push Rod |
| 5. Grease Seal | 10. Steel Ball |

CLUTCH RELEASE

The clutch release was modified as shown. Refer to Pgs. 65 – 66, noting the following.

1. Before assembling the clutch release, wash and clean the clutch release lever, steel ball assembly, and ball ramp plate with a high flash-point solvent. Dry and lubricate them with grease.
2. Replace the grease seal with new one if it was damaged.
3. Install the adjusting screw and ball ramp plate as a set, fitting the ridge on the engine sprocket cover with the groove in the ramp plate.

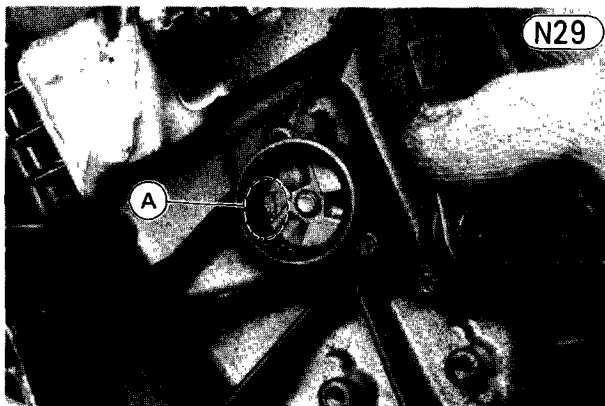

N29

STARTER MOTOR

The starter motor was modified. New starter motor has the permanent magnets inside the yoke instead of the field coils, and there is four carbon brushes on the new motor. Refer to Pgs. 69 – 70, noting the following

Disassembly Notes:

1. Remove the armature out of the yoke assembly towards the gear cover.
2. Remove the brush plate from the yoke, and remove the brush springs (4) from the brush plate. This makes armature installation easy.

Assembly Notes:

1. Terminal Bolt Installation:
 - The projection on the insulator comes to the outside
 - Make sure that the plastic holder, brush and lead assembly are fully seated in the yoke.
 - Tighten the terminal nut to 1.1 kg-m (11 N-m, 95 in-lb)

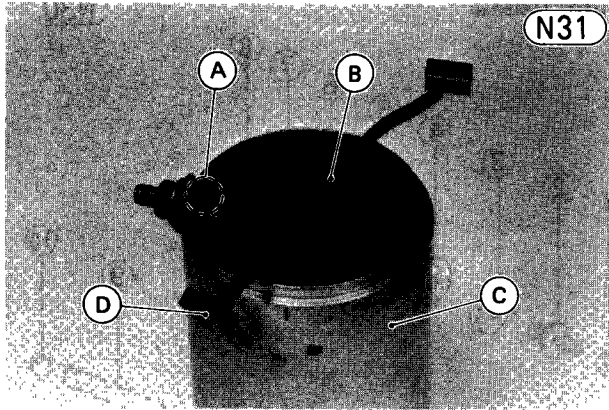

A. Projection
B. Holder
C. Yoke
D. Brush and Lead Assembly

plate has four tongues; fit three of them into the plastic plate notches, and one into the yoke notch.

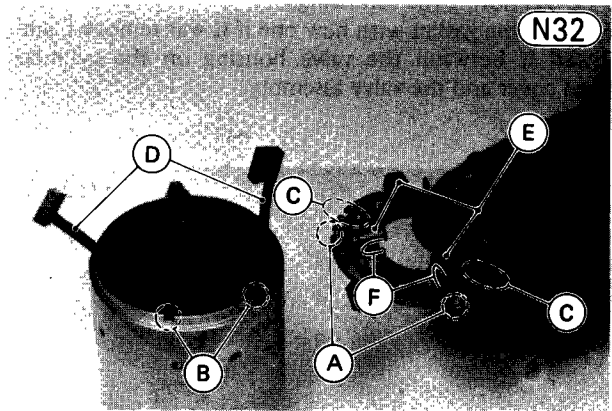

A. Tongues
B. Notches
C. Ω-Shaped Notches
D. Leads
E. Brush Holders
F. U-Shaped Notches

2. Brush Plate and Armature Installation:
●Install the brush plate on the yoke fitting the brush leads into the Ω-shaped notches in the plate. The brush

Starter Motor

N33

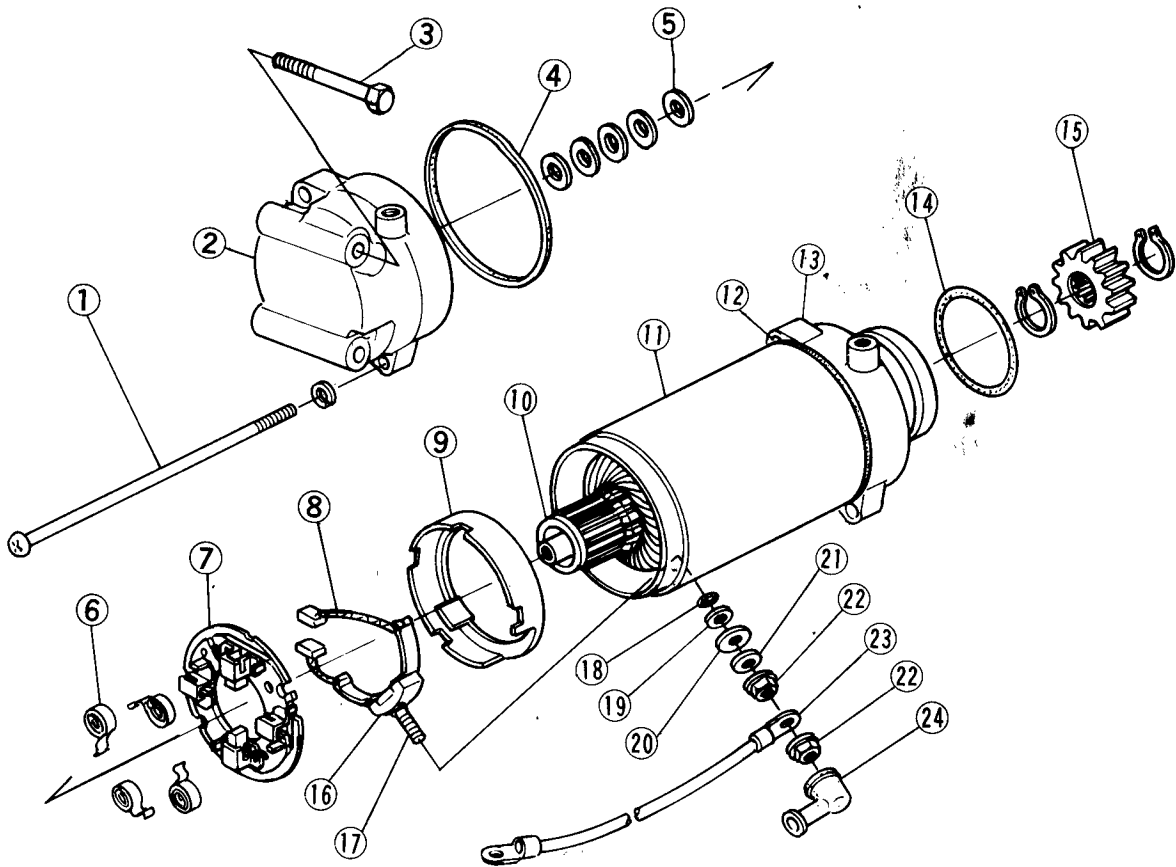

1. Screw x 2	7. Brush Plate	13. Gear Cover	19. Insulator (Small)
2. End Cover	8. Brush and Lead Assy	14. O-Ring	20. Insulator (Large)
3. Mounting Bolt x 2	9. Plastic Holder	15. Pinion	21. Flat Washer
4. O-Ring	10. Armature	16. Insulator	22. Nut
5. Shims	11. Yoke Assy	17. Terminal Bolt	23. Lead

- Insert the brushes fully into the brush holders fitting the brush lead into the U-shaped notch in the holder.
- Insert the armature into the yoke. Fit the brushes correctly on the commutator.
- Assemble the gear cover side of the starter motor. Match the internal gear groove with the key in the gear cover, and fit the projection in the yoke with the end plate notch and the internal gear groove.

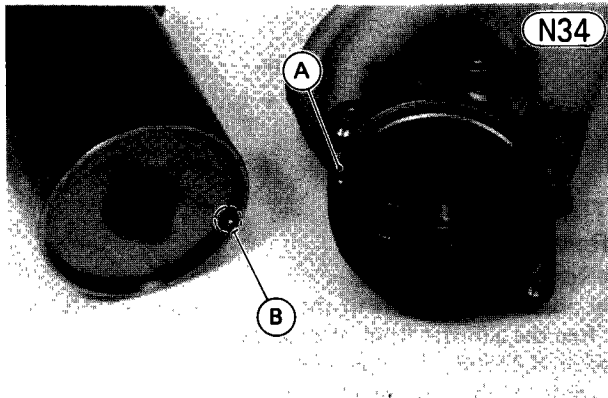

A. Key B. Projection

- Keeping the motor upright, install the brush springs. Fit the spring on the spring post halfway; the post must be positioned in the D-shaped end of the spring. Turn the other end of the spring a half turn clockwise, and fit the end in the brush groove. Push the spring all the way on the post until it stops at the stepped portion.

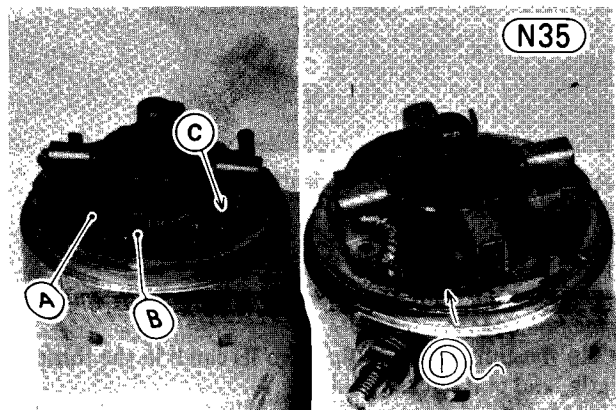

A. Spring Post B. Brush Groove C. Stepped Portion

- Assemble the end cover side of the motor. Fit the

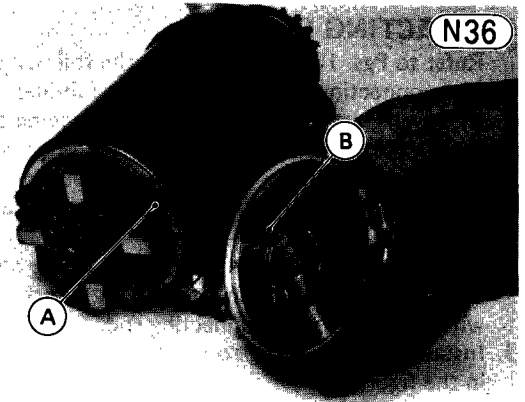

A. Tongue B. Groove

NOTE: When all the gear cover, internal gear, yoke, brush plate, and end cover are correctly assembled, the lines on the covers and yoke align.

- Tighten the screws to 0.55 kg-m (5.4 N-m, 48 in-lb) of torque.

TRANSMISSION

Refer to Pgs. 98 – 103, noting the following.

Drive Shaft:

The copper washer (⑥ in Fig. F63) was deleted from the drive shaft assembly, because the drive shaft needle bearing and its outer race were modified about their sizes.

Output Shaft:

The copper washer (⑤9 in Fig. F63) was deleted from the output shaft assembly, because the output shaft needle bearing and its outer race were modified

298 SUPPLEMENT—1982 MODEL

CONNECTING RODS

Refer to Pgs. 104 – 105, noting the following.

1. The connecting rods were holed to lubricate and cool the lower part of the piston with the engine oil. Also, the upper bearing insert half (con-rod side) was modified. The new bearing insert half has a hole to connect the crankshaft oil passage to the con-rod oil hole.
2. Install the upper bearing insert half to the connecting rod so that the hole in the bearing insert half aligns with the hole in the connecting rod.
3. Install the connecting rod to the crankshaft as shown in the figure.

Connecting Rod, Bearing Insert Installation

(N37)

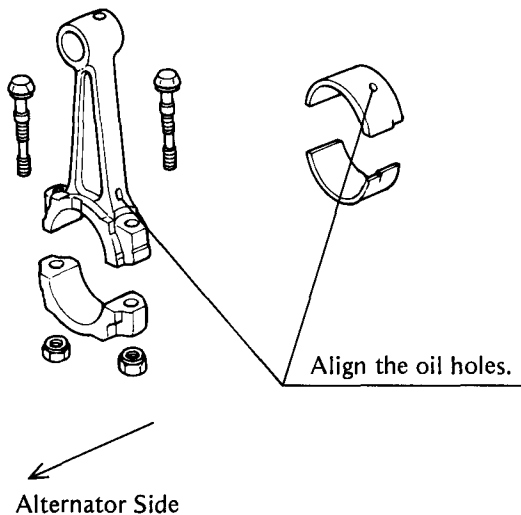

4. Select the upper bearing insert half (con-rod side) in accordance with the following table. This bearing insert half has a oil hole.

Table N11 Upper Bearing Insert Half Selection

Con-Rod Marking / Crank-shaft Marking	○	No Mark
○	Black P/N: 92028-1157	Brown P/N: 92028-1158
No Mark	Green P/N: 92028-1156	Black P/N: 92028-1157

5. Select the lower bearing insert half (big end cap side) in accordance with the following table. This bearing

Table N12 Lower Bearing Insert Half Selection

Con-Rod Marking / Crank-shaft Marking	○	No Mark
○	Black P/N: 13034-051	Brown P/N: 13034-052
No Mark	Green P/N: 13034-050	Black P/N: 13034-051

THROTTLE CABLE

Removal:

- Remove the fuel tank.
- Loosen the locknuts of the throttle cable adjuster, and free the adjuster from its bracket.
- For KZ750R, lift the lower end of the outer throttle cable off the cable bracket on the carburetor.
- Slip the inner cable tip out of the pulley, and free the lower end of the throttle cable from the carburetors.
- Remove the cable elbow holder screw, and remove the elbow holder from the lower half of the right switch housing.

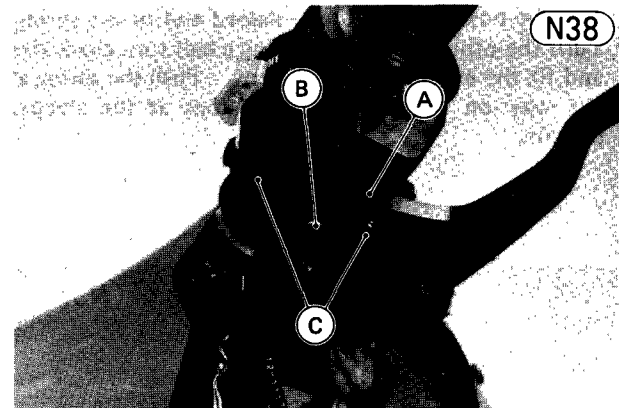

A. Elbow Holder
B. Holder Screw

C. Switch Housing Screws

- Remove the right switch housing screws (2), and open the housing.
- Slip the throttle cable tip from its catch in the throttle grip, and pull out the cable.

Installation Notes:

1. Before installing the throttle cable, lubricate it.
2. The cable should be naturally routed.
3. The lower half of the housing has a small projection which fits into a hole in the handlebar.

SWING ARM

The numbers of the needle bearings at the swing arm pivot were changed from four to two. And, the grease seal was attached to both ends of the swing arm pivot.

Refer to Pgs. 143 – 145, noting the following.

1. Install new needle bearings in the swing arm bearing housing using the bearing driver set (special tool). Apply oil to the outside surface of the bearings, and press in each bearing so that it sinks 5 mm from the end of the bearing housing.

Needle Bearing, Grease Seal Installation

(N39)

1. Needle Bearing
2. Grease Seal

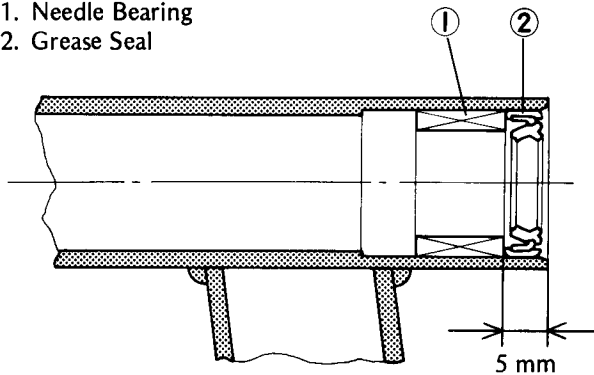

2. Replace the grease seals with new ones, and install each grease seal using the same special tools that were used to install the needle bearings. Press in each seal until it stops at the needle bearing.
3. Lubricate the swing arm before installation (Pg. 276).

FUEL LEVEL SENSOR (on KZ750R)

Installation Notes:

1. Install the fuel level sensor to the fuel tank so that the arrow mark on the bottom of the sensor points to the front.

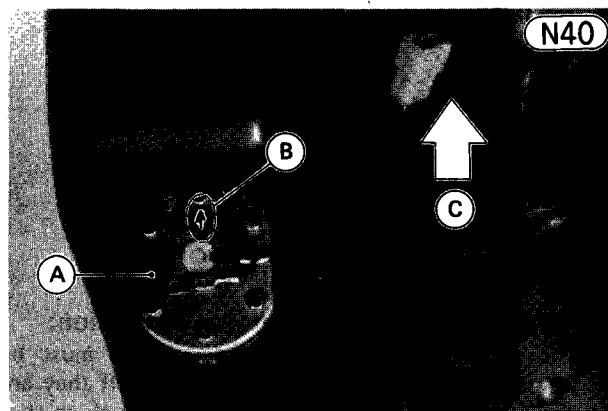

A. Fuel Level Sensor C. Front

2. Check for fuel leak after installing and filling the tank.

CARBURETORS (on KZ750R)

WARNING Gasoline is extremely flammable and can be explosive under certain conditions. Turn the ignition switch OFF. Do not smoke. Make sure that area is well-ventilated and free from any source of flame or sparks, this includes any appliance with pilot light.

Removal:

- Loosen the carburetor holder clamps (4).
- Slide the spring bands (4) on the air cleaner ducts out of place.
- Disconnect the following parts from the carburetors, and slip the carburetors up and out of place to the right side.
 - Throttle cable lower end
 - Vacuum hoses to the vacuum switch valve (US model only)

Installation Notes:

1. Check the carburetor holders for crack or other damage, replace the damaged holders with new ones. Apply a non-permanent locking agent to the carburetor holder mounting Allen bolt threads, and tighten bolts to 1.4 kg-m (14 N-m, 10.0 ft-lb) of torque.
2. If the carburetors were disassembled, visually synchronize the throttle (butterfly) valves as follows:
 - Check to see that all butterfly valves open and close smoothly without no binding when turning the pulley.
 - Visually check the clearance between the butterfly valve and the carburetor bore in each carburetor.

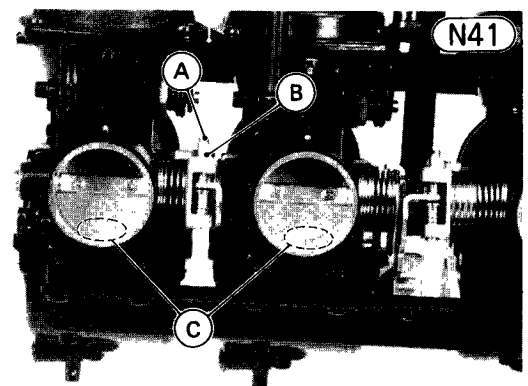

A. Balance Adjusting Screw C. Clearance

300 SUPPLEMENT—1982 MODEL

- If there is a difference between any two carburetors, loosen the locknut(s) and turn the balance adjusting screw(s) to obtain the same clearance.
- Tighten the locknut(s).
- 3. Run the throttle cable between the right fork leg and the head pipe, and right side of the frame top tube.
- 4. Connect the vacuum hose(s) to the following hose fittings:
 - Two hoses to the vacuum switch valve (US model only) → #1 and #4 carburetors
 - One hose to fuel tap → #2 carburetor
- 5. After completing installation, adjust the following items.
 - Throttle Cable
 - Idle Speed
 - Carburetor Synchronization

Carburetor Disassembly (each carburetor):

- NOTE:** 1. The carburetor parts listed below can be removed without separating the carburetors from the mounting plates.
- Vacuum Piston and Diaphragm Assembly
 - Jet Needle
 - Needle Jet
 - Pilot Screw
 - Pilot Jet
 - Main Jet
 - Float
 - Float Valve Needle
 - Float Valve Seat
2. The carburetor parts listed below can be removed after separating the carburetors from the mounting plates.
- Starter Plunger

Bottom End:

NOTE: The float pin is lightly press-fitted in the pin holder. To remove the pin, use a starting punch.

CAUTION Be careful not to damage the float pin holder by hitting the holder instead of the pin.

Top End:

NOTE: To remove the pilot screw on the US model, punch and pry off the plug with an owl or other suitable tools, turn in the pilot screw and count the number of turns until it seats fully but not tightly, and then remove the pilot screw, spring and O-ring. This is to set the pilot screw on its original position when assembling.

Carburetor Assembly Notes (each carburetor):

1. Replace any O-ring, diaphragms, plastic plug, and gasket if damaged or deteriorated.
2. When installing the vacuum piston and diaphragm assembly, observe the following:
 - Align the diaphragm tongue with the notch in the upper chamber cover mating surface, and fit the dia-

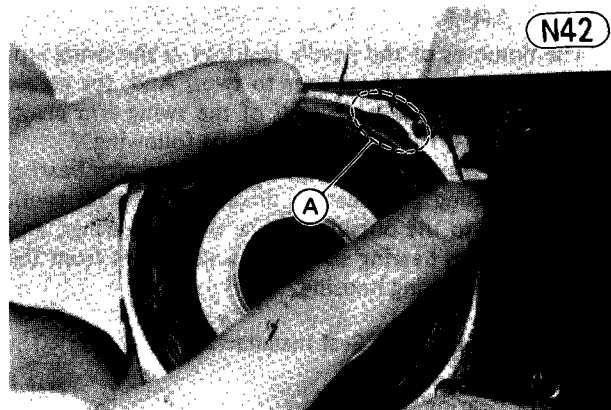

A. Align tongue with notch.

- After installing the upper chamber cover, check that the vacuum pistons slide up and down smoothly without binding in the carburetor bores.
- 3. For the US model, install the pilot screw and plug as follows:
 - Turn in the pilot screw fully but not tightly, and the back it out the same number of turns counted during disassembly.
 - Install a new plug in the pilot screw hole, and apply a small amount of a bonding agent to the circumference of the plug to fix the plug.

CAUTION Do not apply too much bond on the plug to keep the pilot screw itself from being fixed.

Plug Installation (US model only)

(N43)

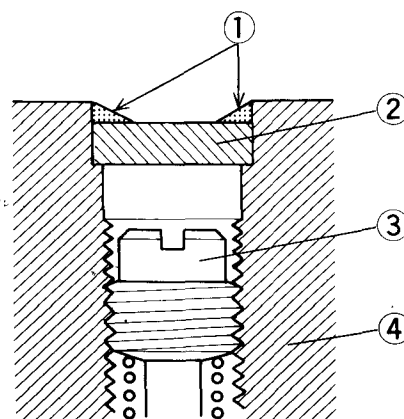

1. Apply a bonding agent.
2. Plug
3. Pilot Screw
4. Carburetor Body

Assembly Notes after Carburetor Separation:

1. The centerlines of the carburetor bores must be parallel both horizontally and vertically. If they are not, loosen the mounting screws just enough to that the carburetors are able to move, align them on a flat

Carburetors

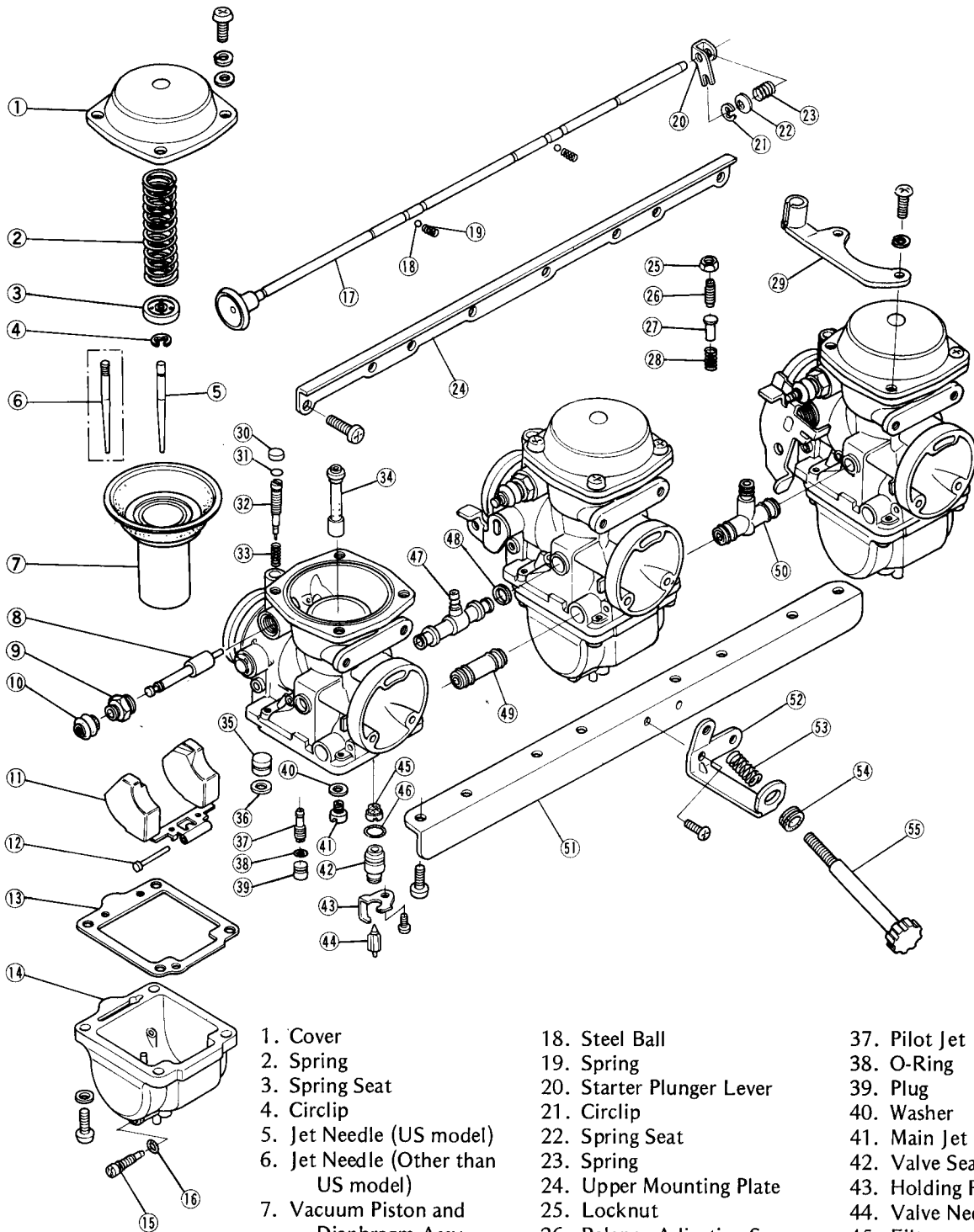

- | | | |
|-------------------------------------|-----------------------------|--------------------------|
| 1. Cover | 18. Steel Ball | 37. Pilot Jet |
| 2. Spring | 19. Spring | 38. O-Ring |
| 3. Spring Seat | 20. Starter Plunger Lever | 39. Plug |
| 4. Circlip | 21. Circlip | 40. Washer |
| 5. Jet Needle (US model) | 22. Spring Seat | 41. Main Jet |
| 6. Jet Needle (Other than US model) | 23. Spring | 42. Valve Seat |
| 7. Vacuum Piston and Diaphragm Assy | 24. Upper Mounting Plate | 43. Holding Plate |
| 8. Starter Plunger | 25. Locknut | 44. Valve Needle |
| 9. Plunger Cap | 26. Balance Adjusting Screw | 45. Filter |
| 10. Dust Cover | 27. Rod | 46. O-Ring |
| 11. Float | 28. Spring | 47. 3-way Joint |
| 12. Float Pin | 29. Cable Bracket | 48. O-Ring |
| 13. Gasket | 30. Plug (US model) | 49. Connecting Pipe |
| 14. Float Bowl | 31. O-Ring | 50. 3-way Joint |
| 15. Drain Plug | 32. Pilot Screw | 51. Lower Mounting Plate |
| 16. O-Ring | 33. Spring | 52. Bracket |
| | 34. Needle Jet | 53. Spring |
| | 35. Plug | 54. Bushing |

302 SUPPLEMENT—1982 MODEL

2. Choke shaft installation:

- Apply grease to the shaft positioning springs and balls (2 ea), and put the spring and ball in this order into the #2 and #3 carburetors.
- Install the spring in each starter plunger lever.
- Apply grease to the shaft hole in the carburetors, and insert the shaft through each plunger lever, spring seat, and spring while engaging the lever with the plunger groove.

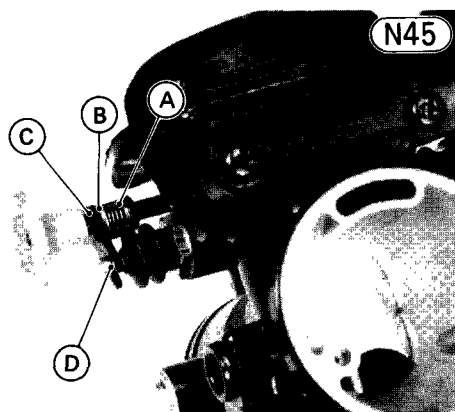

A. Spring
B. Spring Seat
C. Lever
D. Groove

- Install the circlips (4) on the choke shaft. The circlip must be on the left side of the spring seat.

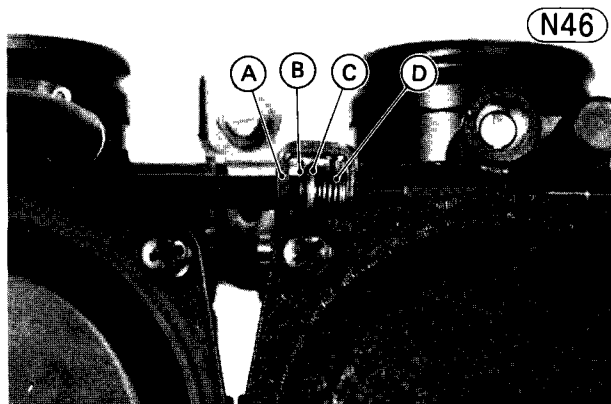

A. Lever
B. Circlip
C. Spring Seat
D. Spring

- Check to see the choke shaft slides left to right smoothly without abnormal friction. The choke shaft has three stop positions:
 - On position — the fully-pulled-out position, the rod end of the #2 and #4 carburetors contacts against the #1 and #3 carburetors respectively.
 - Halfway position — the first click position in the choke return way.
 - Off position — the second click position in the choke return way, the plunger lever springs must be compressed a little to press securely the starter

On Position:

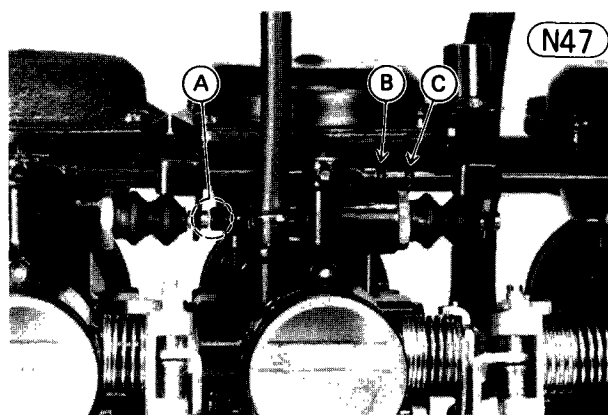

A. Rod end contacts against carburetor body.
B. Halfway-Position Groove
C. Off-Position Groove

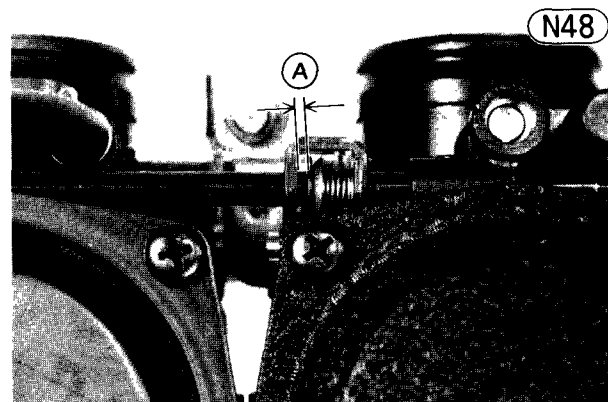

A. Spring is compressed and there must be clearance.

CAUTION Fuel mixture trouble could result if the plunger does not seat properly in its rest position after the choke knob is returned.

MUFFLERS (on KZ750R)

Each muffler can be separated from the exhaust pipe by loosening the clamp at the muffler front end and removing the muffler mounting bolts.

The exhaust pipes, #1 and #4, are assembled by the connecting pipes which are welded to both exhaust pipes. And, this exhaust pipe assembly is mounted to the bottom of the engine by the mounting bolt.

The #2 and #3 exhaust pipes can be removed from the #1 and #4 exhaust pipe assembly.

Removal Note:

- The rear part of both right and left mufflers can be removed from the motorcycle, remaining the front

Mufflers

N49

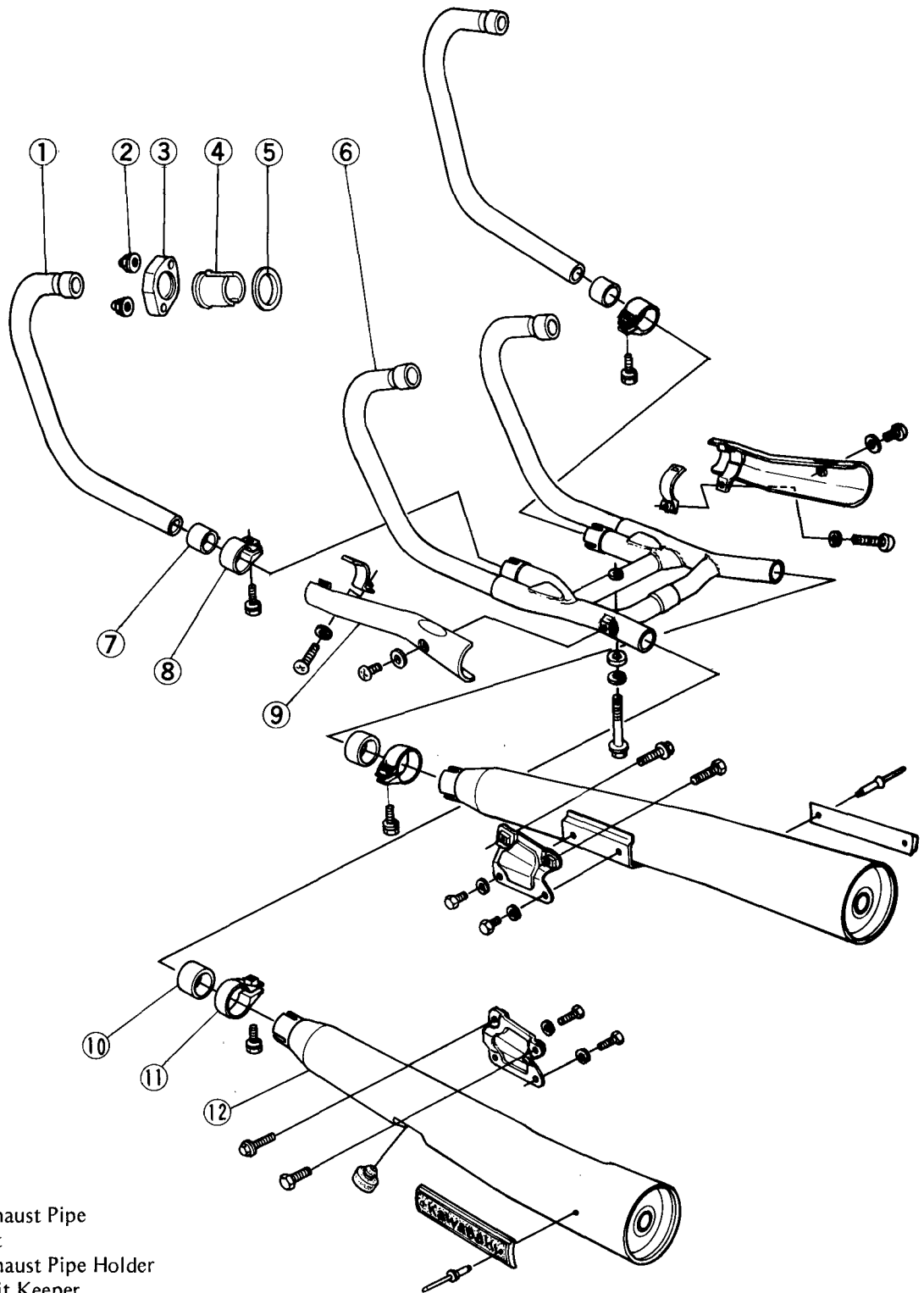

1. Exhaust Pipe
2. Nut
3. Exhaust Pipe Holder
4. Split Keeper
5. Gasket
6. Exhaust Pipe Assy
7. Gasket
8. Clamp
9. Muffler Cover
10. Gasket
11. Clamp

304 SUPPLEMENT—1982 MODEL

Installation Notes:

1. There is an identification mark on the #2 and #3 exhaust pipes. The mark is at the lower part of each pipe. Do not mix up those exhaust pipes.
2. Check to see that the gasket is between the exhaust pipe end and the cylinder head.
3. Tighten the muffler mounting bolts, nuts, and clamp bolts in the order and method indicated below.
 - First, tighten all the bolts and nuts to snug fit.
 - Secondly, tighten the exhaust pipe holder nuts (8) evenly to avoid exhaust leaks.
 - Lastly, tighten the rest of the mounting bolts and clamp bolts securely.
4. Thoroughly warm up the engine, wait until the engine grows cold, and retighten all the clamp bolts.

CAMSHAFTS (on KZ750R)

For the KZ750R, the exhaust camshaft has not the tachometer gear because the electric tachometer system is used on this motorcycle.

1. The inlet and exhaust camshafts are not identical. The exhaust camshaft has a rising portion at the place where was cutted the tachometer gear on the other model's exhaust camshaft (Fig. E41 on Pg. 54).
2. Refer to Pgs. 53 — 56, noting the above information.

OIL PASSAGE PLUG (on KZ750R)

Motorcycle on KZ750R has not the oil pressure switch. So, the oil passage opening should be plugged as the following.

- Apply a non-permanent locking agent to the threads of the oil passage plug, and tighten it to 1.3 kg-m (13 N-m, 113 in-lb) of torque.

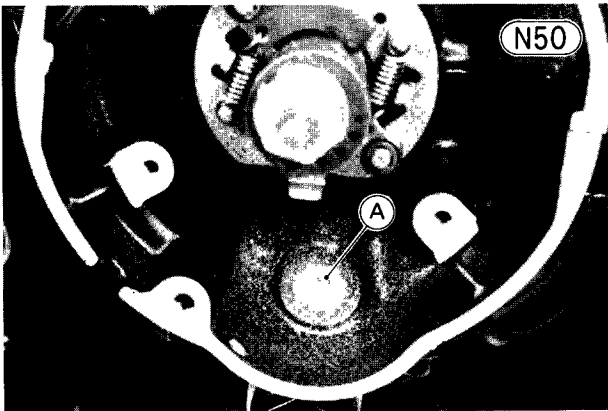

OIL COOLER (on KZ750R)

Motorcycle on KZ750R has the oil cooler which is located in front of the engine.

CAUTION To prevent damage of the oil cooler brackets, hold the oil tube fitting with a wrench from turning during oil tube connecting nut loosening and tightening.

Removal Note:

- Before removing the oil cooler or oil tubes, place an oil pan beneath the oil cooler and tubes.

Oil Cooler

(N51)

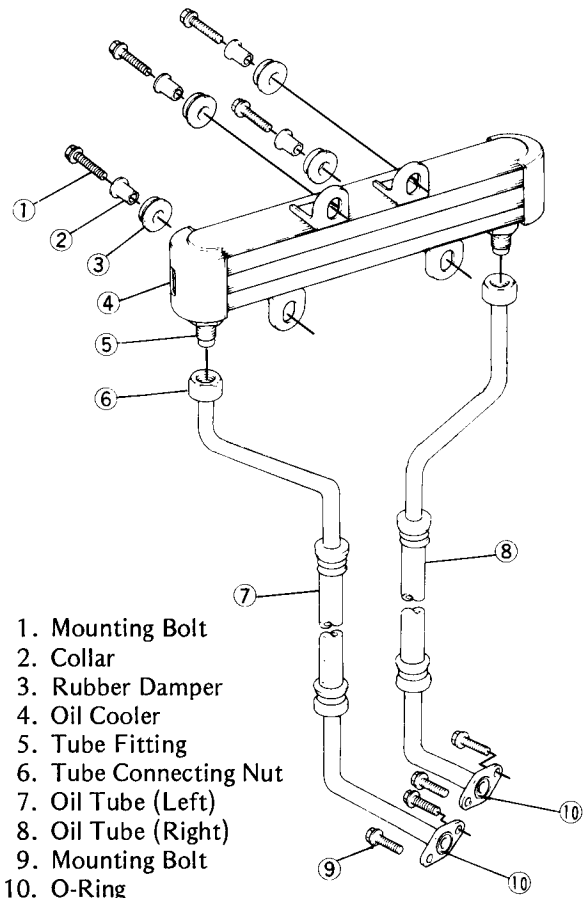

1. Mounting Bolt
2. Collar
3. Rubber Damper
4. Oil Cooler
5. Tube Fitting
6. Tube Connecting Nut
7. Oil Tube (Left)
8. Oil Tube (Right)
9. Mounting Bolt
10. O-Ring

Installation Notes:

1. Install the oil cooler and oil tubes as the following.
 - First, tighten all the bolts and nuts loosely.

CAUTION To prevent damage of the tube fitting threads, apply a oil to the threads of the fittings, and connect the oil tubes to the fittings by turning the connecting nuts with hands until the nuts become hard to turn. The damaged threads cause the oil leakage.

- Secondly, tighten the oil tube lower mounting bolts securely, and then tighten the oil cooler mounting bolts securely too.
- Finally, tighten the oil tube connecting nuts to 2.2 kg-m (22 N-m, 16.0 ft-lb) of torque.

ENGINE REMOVAL (on KZ750R)

Removal:

- Set the motorcycle up on its center stand, and drain out the engine oil.
- Remove the following parts.
 - Fuel Tank
 - Carburetors
 - Air Cleaner housing
 - Ignition Coils
 - Vacuum Switch Valve (US model only)
 - Mufflers
 - Oil Cooler
 - Engine Sprocket Cover, Knock Pins
 - Engine Sprocket
 - Clutch Push Rod
- Free all cables and leads as the following, and take them properly positioned on the engine and frame so that they will not get damaged during engine unit removal.
- Slide the rubber cap out of place, remove the nut and lockwasher, and free the starter motor lead from the starter motor terminal.

- Disconnect the neutral switch lead from the switch, and disconnect the alternator leads and oil level sensor lead. Free the leads from the engine.
- Disconnect the rear brake light switch leads.
- Remove the bolt and lockwasher, and remove the battery negative ground lead from the engine.
- Disconnect the pickup coil 4-pin connector, and free the leads from the frame.
- Check that the clutch cable and throttle cable are free from the engine unit.
- Jack or lever the engine up slightly to take the weight off the mounting bolts.
- Remove the engine mounting bolts and engine mounting bracket bolts. Be careful not to damage the threads upon removal. The rear upper mounting bolt has the spacers. The rear brake light switch is mounted on the rear upper right bracket.
- Left the engine straight up keeping it level, then move it to the right slightly so the rear and front of the engine slips over the lower engine mounts, and pull the engine out to the lower engine mounts, and pull the engine out to the right side.

Engine Mountings

N52

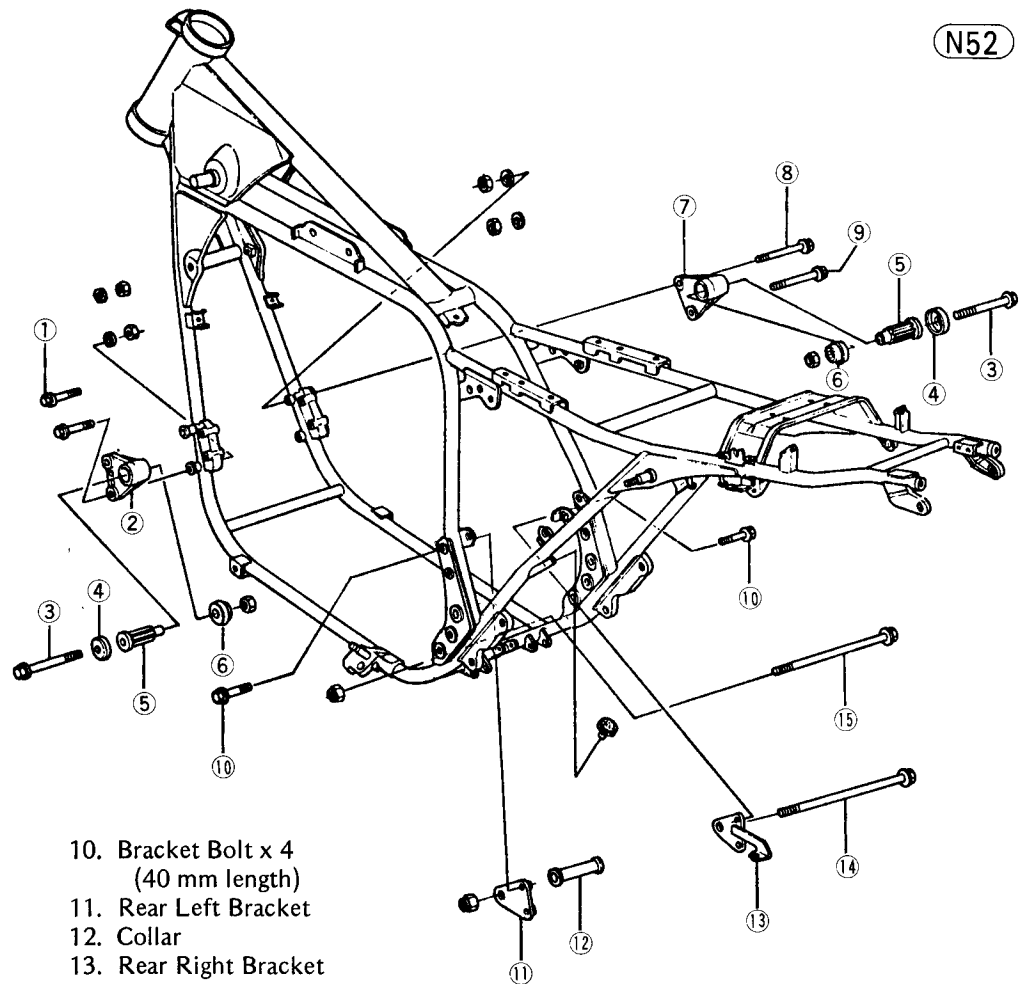

- | | |
|---|---|
| 1. Bracket Bolt x 2
(55 mm length) | 10. Bracket Bolt x 4
(40 mm length) |
| 2. Front Left Bracket
(marked "1192") | 11. Rear Left Bracket |
| 3. Front Engine Bolt x 2
(105 mm length) | 12. Collar |
| 4. Cap x 2 | 13. Rear Right Bracket |
| 5. Damper x 2 | 14. Rear Upper Engine Bolt
(250 mm length) |
| 6. Damper x 2 | 15. Rear Lower Engine Bolt |
| 7. Front Right Bracket
(marked "1193") | |
| 8. Bracket Bolt
(80 mm length) | |
| 9. Bracket Bolt | |

306 SUPPLEMENT—1982 MODEL

Installation Notes:

1. Check the dampers are installed on the front engine mounting brackets. If they are not, press the longer ones in the brackets and fit the shorter ones with a bonding agent.
2. Tighten the engine mounting bolts and engine mounting bracket bolts to the specified torque.
 - Engine Mounting Bolts (⑥, ⑭, and ⑮ in Fig. N52):
4.0 kg-m (39 N-m, 29 ft-lb)
 - Bracket Bolts (①, ⑦, ⑨, and ⑩):
2.4 kg-m (24 N-m, 17.5 ft-lb)
3. Check and adjust the following items.
 - Clutch
 - Throttle Grip
 - Rear Brake Light Switch
 - Drive Chain
 - Engine Oil

TURN SIGNAL ASSY (on KZ750R)

Refer to Pgs. 130 – 132, noting the following.

- Tighten the turn signal mounting nuts to 1.3 kg-m (13 N-m, 113 in-lb) of torque.

CAUTION Do not apply a torque more than 1.5 kg-m (15 N-m, 11.0 ft-lb) to the turn signal mounting nuts. Over-tightening may cause the damage of the turn signal assy bolt.

FRONT BRAKE LIGHT SWITCH (on KZ750R)

Installation Note:

- Apply a non-permanent locking agent to the threads of the front brake light switch mounting screw, and tighten the screw to install the switch.

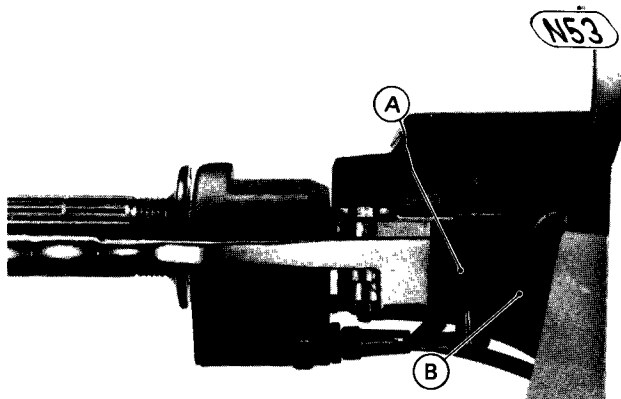

HANDLEBARS, HOLDERS (on KZ750R)

Left Handlebar Removal:

- Loosen the clutch lever holder bolt.
- Remove the screws, and open the left switch housing.
- Remove the handlebar clamp bolt and end plug, and pull out the handlebar.

Right Handlebar Removal:

- Loosen the front master cylinder clamp bolts.
- Remove the screws, open the right switch housing, and take off the throttle grip.
- Remove the handlebar clamp bolt and end plug, and pull out the handlebar.

Handlebar Holder Removal (each holder):

- Remove the screws, and take off the stem head cover.
- Pull off the rubber cap.
- Remove the handlebar holder bolt, positioning plate Allen bolt, and positioning plate, and take off the holder.

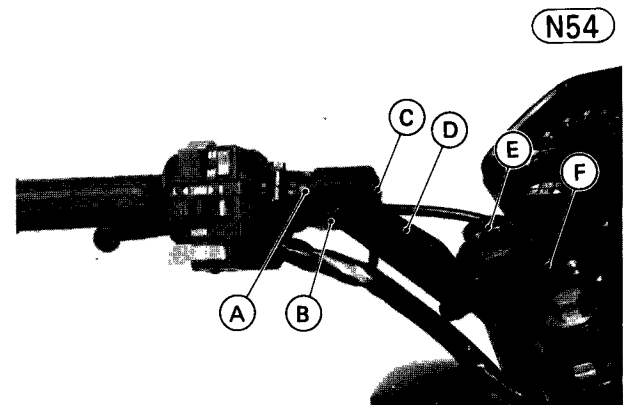

- | | |
|---------------|----------------------|
| A. Handlebar | D. Holder |
| B. Clamp Bolt | E. Holder Bolt |
| C. Plug | F. Positioning Plate |

Installation Notes:

1. The handlebar holder positioning plate must be installed so that triangular mark on the plate points to the rear.

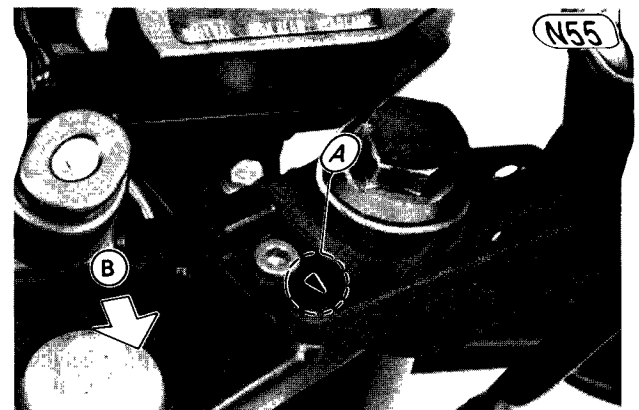

2. The handlebar holder must be fitted on the stem head without any clearance. Install the holder as following.
 - Loosen the front fork clamp bolts (2 on each leg) and slide the fork inner tube upper end is slightly down with the upper surface of the stem head.

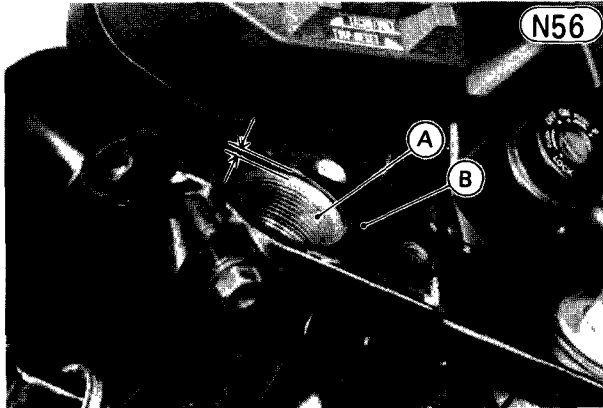

A. Inner Tube B. Stem Head

- Lightly tighten the front fork upper clamp bolt to give friction to the inner tube. Leave the lower clamp bolts loosen.
 - Put the handlebar holder and positioning plate, and handtighten the positioning plate Allen bolt and holder bolt.
 - Tighten the bolts in the following sequence.
 - (1) Holder Bolt: 10.0 kg-m (98 N-m, 72 ft-lb)
 - (2) Fork Clamp Bolts
 - Upper: 2.0 kg-m (20 N-m, 14.5 ft-lb)
 - Lower: 3.8 kg-m (37 N-m, 27 ft-lb)
 - (3) Positioning Plate Allen Bolt
3. Tighten the handlebar clamp bolt to 3.0 kg-m (29 N-m, 22 ft-lb) of torque.
 4. The lower half of both the left and right switch housings has a small projection. Fit the projection into a small hole in the handlebar.

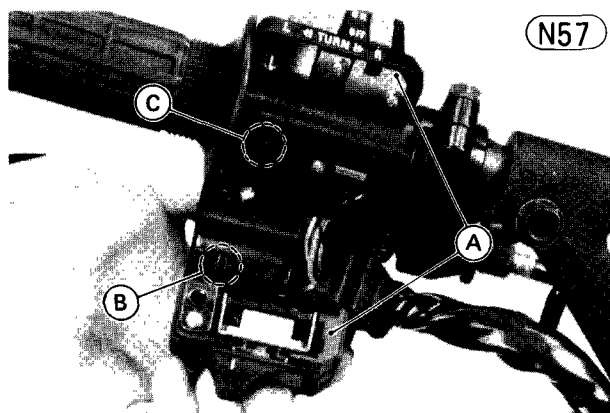

A. Switch Housing C. Hole
B. Small Projection

5. The master cylinder clamp must be installed with the small projection towards the throttle grip. Tighten the upper clamp bolt first, and then the lower clamp bolt both to 0.90 kg-m (8.8 N-m, 78 in-lb) of torque. There will be a gap at the lower part of the clamp

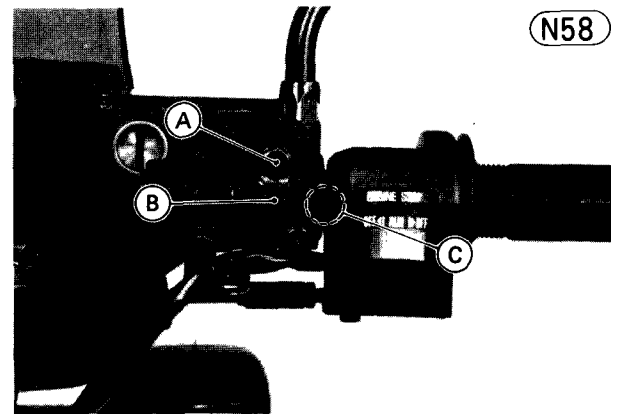

A. Tighten upper clamp bolt first. C. Projection
B. Clamp

6. Check and adjust the following items:
 - Throttle grip
 - Clutch
 - Front brake
 - Rear view mirrors

FRONT FORK (on KZ750R)

A hole in each fork leg just above the steering stem base is covered by the connecting bracket. A groove and hole in the connecting bracket leads to the connecting hose. Thus, the air chambers in the two fork legs are connected by the connecting hose and under equal pressure.

Each fork leg has two rebound springs, one of the springs is a thick and the other is a thin.

NOTE: 1. Do not compress only one of the fork leg. As this could cause the fork oil to flow through the connecting hose to the other fork leg, and the oil levels will change.

2. After removal, be careful not to spill the oil through the hole in the inner tube.

Fork Leg Removal (each leg):

- Remove the following parts.
 - Front wheel
 - Front fender
 - Front brake caliper
 - Fairing
 - Handlebar holder
- Release the air through the air valve.
- Loosen the upper and lower clamp bolts, and work the

308 SUPPLEMENT-1982 MODEL

Front Fork

N59

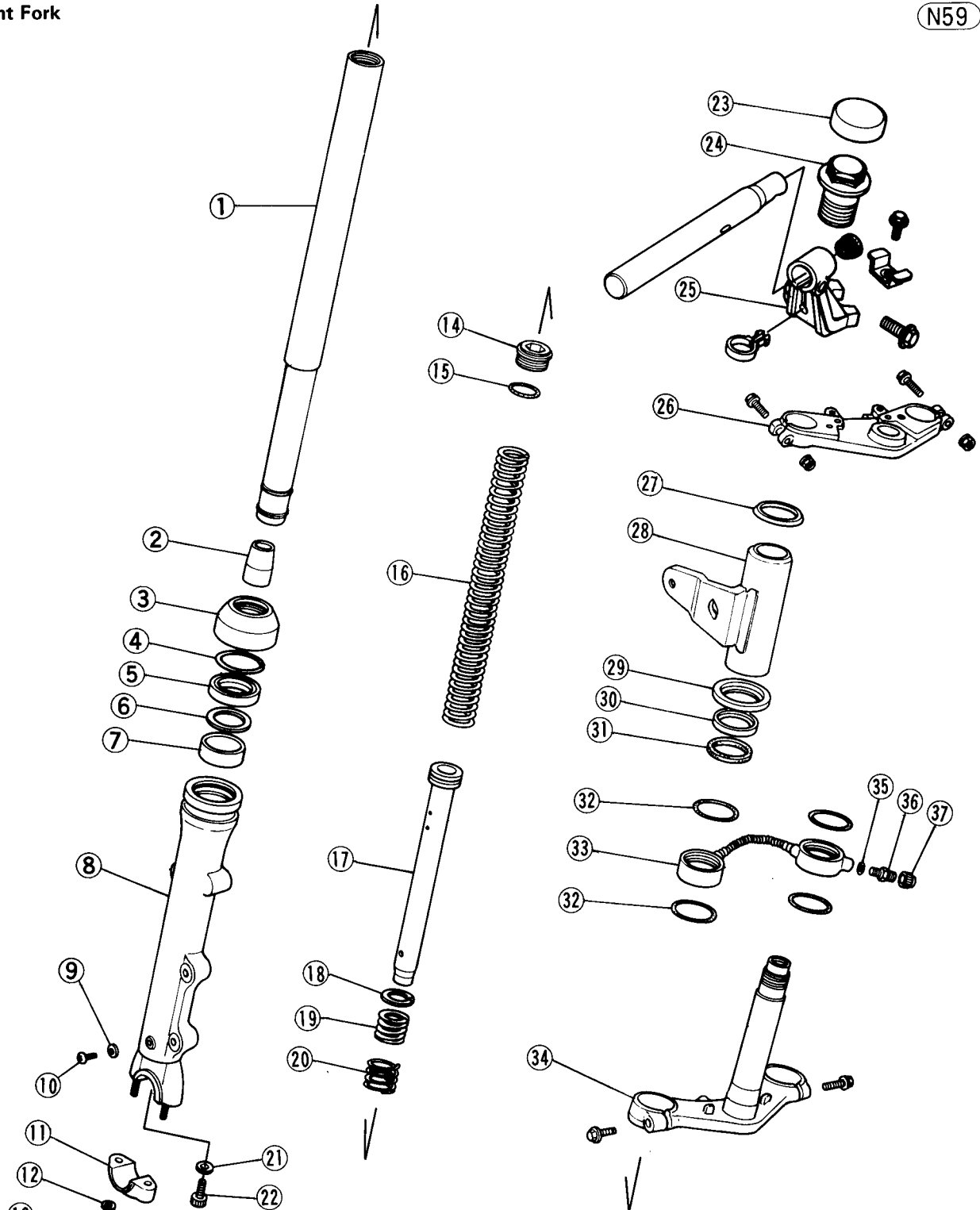

- | | | | |
|------------------|-----------------|------------------------------|--------------------------|
| 1. Inner Tube | 9. Gasket | 18. Piston Ring | 28. Fork Cover |
| 2. Cylinder Base | 10. Drain Screw | 19. Rebound Spring (Thicker) | 29. Stem Base Cover |
| 3. Dust Cover | 11. Axle Clamp | 20. Rebound Spring (Thinner) | 30. Damper Ring |
| 4. Retainer | 12. Lockwasher | 21. Gasket | 31. Rubber Damper |
| 5. Oil Seal | 13. Nut | 22. Allen Bolt | 32. O-Ring |
| 6. Washer | 14. Top Plug | 23. Rubber Cap | 33. Connecting Hose Assy |
| 7. Guide Bush | 15. O-Ring | 24. Holder Mounting Bolt | 34. Steering Stem Base |
| | 16. Main Spring | 25. Handlebar Holder | 35. O-Ring |
| | 17. Piston and | 26. Steering Stem Head | 36. Air Valve |
| | | | 37. Air Valve |

Fork Leg Installation Notes (each leg):

1. Apply oil to the O-ring inside the connecting bracket to reduce friction and to avoid O-ring damage, and then slide the fork leg up through the stem base, connecting bracket, and stem head, until the inner tube upper end is slightly down with the upper surface of the stem head.
2. If the air valve was removed, apply a non-permanent locking agent to the threads of air valve, and tighten it to 0.80 kg-m (7.8 N-m, 69 in-lb) of torque.
3. If the top plug was loosened during removal, tighten it to 2.3 kg-m (23 N-m, 16.5 ft-lb) of torque.
4. Tighten the front brake caliper mounting bolts to 3.0 kg-m (29 N-m, 22 ft-lb) of torque.
5. Check and adjust the following items:
 - Front fork air pressure
 - Front brake
 - Rear view mirrors

STEERING STEM, BEARINGS (on KZ750R)

Removal:

- Remove the following parts.
 - Fuel tank
 - Front wheel
 - Fairing
 - Front fork legs
 - Headlight unit, housing
 - Front turn signals, front fork covers
 - Handlebars, holders
 - Remove the mounting bolts (2), free the brake hose joint from the stem base, and remove the whole front brake assembly as a set.
 - Remove the stem head bolt and flat washer.
 - Remove the steering stem head together with the meter assembly.
- CAUTION** Place the stem head so that the correct side of the meters are up. If a meter is left upside down or sideways for any length of time, it will malfunction.
- Push up on the stem base, and remove the steering stem locknuts with the stem nut wrench (special tool), then remove the steering stem and stem base (single unit).
 - Remove the steering stem cap and upper tapered roller bearing inner race.
 - To remove the outer races pressed into the head pipe, install the stem bearing remover (special tool) as shown below, and hammer the stem bearing remover to driver it out.

NOTE: If any steering stem bearing is damaged, it is recommended that both the upper and lower bearings (including outer races) and the steering stem should be

Outer Race Removal

N60

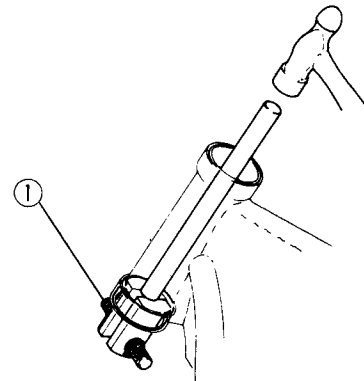

1. Stem Bearing Remover: 57001-1107

Installation Notes:

1. Apply grease to the outer races, and then drive them into the head pipe using the drivers and the driver press shaft (special tools).

Outer Race Installation

N61

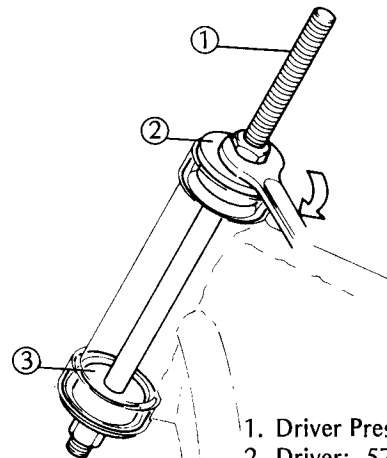

1. Driver Press Shaft: 57001-1075
2. Driver: 57001-1106
3. Driver: 57001-1076

2. Apply grease to the tapered roller bearing, and drive it onto the steering stem using the stem bearing driver and adapter (special tools).

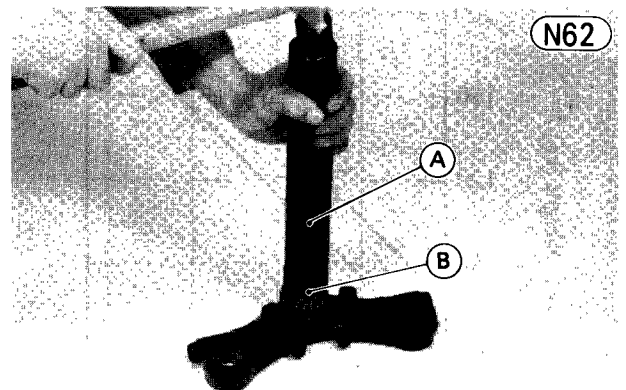

N62

- A. Stem Bearing Driver: 57001-137

310 SUPPLEMENT—1982 MODEL

3. Lubricate the steering stem bearings with grease.
4. Install the lower stem locknut to that the notched side faces down.

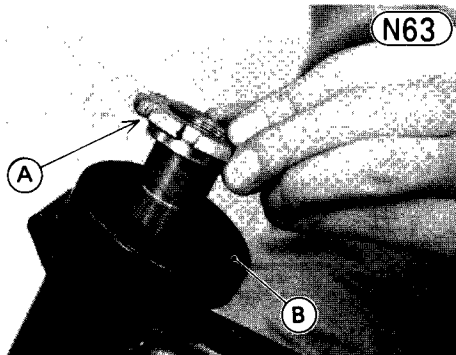

A. Notch Side B. Cap

5. Route the cables and harnesses correctly. The cables and wiring harnesses must not hinder handlebar movement.
6. Check and adjust the following items.
 - Steering
 - Front brake
 - Clutch
 - Throttle cable
 - Rear view mirrors
 - Headlight aim

Maintenance

CARBURETORS (on US model)

High altitude adjustment is not required for the all models of KZ750 four.

CONNECTING RODS

Refer to Pgs. 172 – 174, noting the following.

1. The connecting rods were holed to lubricate and cool the lower part of the piston with the engine oil. Also the upper bearing insert half (con-rod side) was modified. The new bearing insert half has a oil hole to connect the crankshaft oil passage to the con-rod oil hole.
2. See Tables N11 and N12, and see Fig. N37 to select and install the connecting rod bearing inserts.

TRANSMISSION

The needle bearings on the output and drive shafts were modified about thier sizes. So, each bearing race's size was changed. Refer to Pg. 185, noting the following.

Table N13 Needle Bearing Outer Race Inside Diameter

New-style Race	
Standard:	27.005 – 27.022 mm
Service Limit:	27.04 mm
Old-style Race	
Standard:	26.005 – 26.022 mm
Service Limit:	26.04 mm

REAR SHOCK ABSORBERS

Refer to Pgs. 213 – 214, noting the following.

Rear Shock Absorber Spring Force on KZ750L (N64)
(per one shock unit)

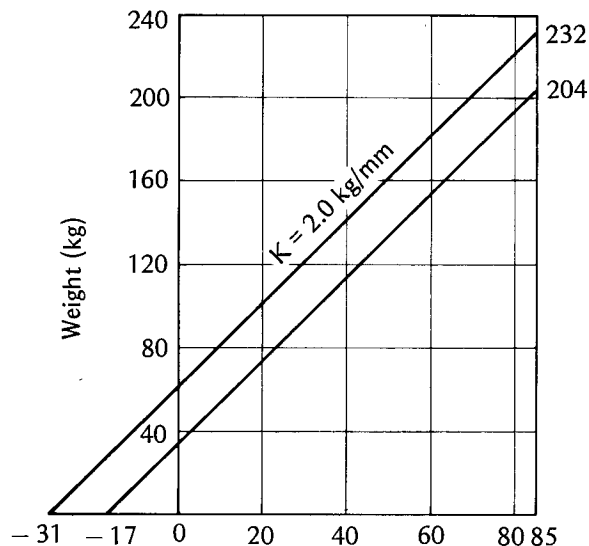

Rear Shock Absorber Spring Force on KZ750R (N65)
of US and Canadian models (per one shock unit)

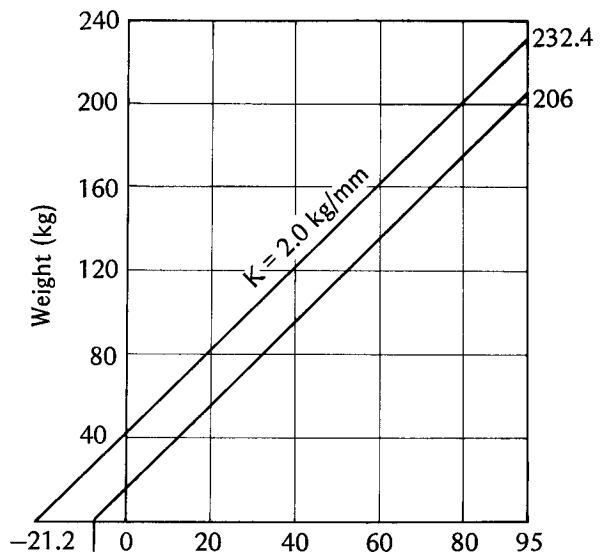

Rear Shock Absorber Spring Force on KZ750R (N66)
of the other than US and Canadian models
(per one shock unit)

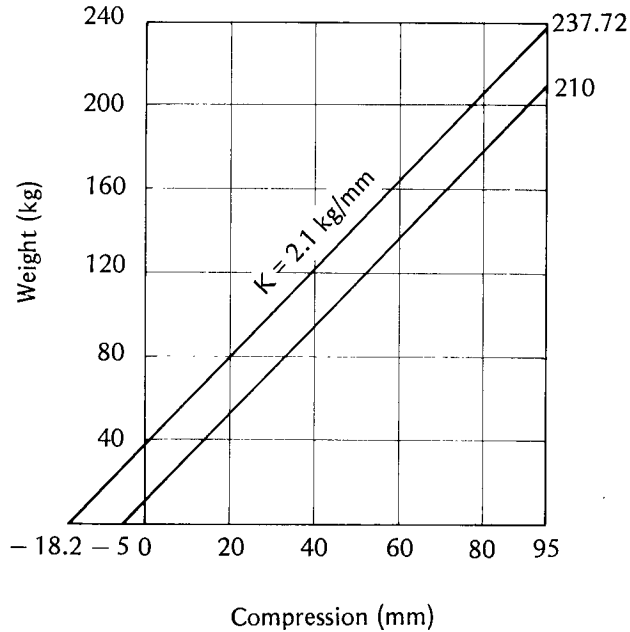

FRONT FORK

Fork Oil (each fork leg)

Viscosity:	SAE10W
Amount of oil	
When changing oil:	About 240 cc (*290 cc)
After disassembly and completely dry:	255 ±4 cc (*308 ±4 cc)
Oil Level (Extended, without main spring):	382 ±2 mm (*436 ±2 mm)

*KZ/Z750H

ELECTRIC STARTER SYSTEM

Starter Motor:

The starter motor was modified. New starter motor has the permanent magnets inside of the yoke instead of the field coils, and there is four carbon brushes on the new motor.

Refer to Pgs. 234 – 236, noting the following.

Brush Spring

Spring tension should be 740 – 860 grams but a spring can be considered serviceable if it will snap the brush firmly into place.

Field Coils

Yoke Assembly Inspection

- Using the x 1 kΩ ohmmeter range, measure the resistance between each (+) side carbon brush and the yoke.
- ★If there is any meter reading, the brush and lead assembly is shorted to the yoke, and the terminal insulator must be replaced.

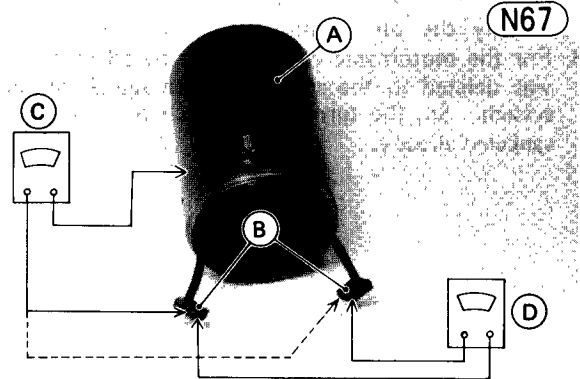

- A. Yoke
- B. (+) Side Brushes
- C. Ohmmeter (x 1 kΩ)
- D. Ohmmeter (x 1 Ω)

- Using the x 1 Ω ohmmeter range, measure the resistance between the (+) side carbon brushes.
- ★If there is not close to zero ohms, the brush leads have an open, and the brush and lead assembly must be replaced.

Brush Plate Inspection

- Using the x 1 Ω ohmmeter range, measure the resistance between the (-) side carbon brushes.
- ★If there is a high resistance or no reading between the brushes, the brush leads are open and the brush plate must be replaced.

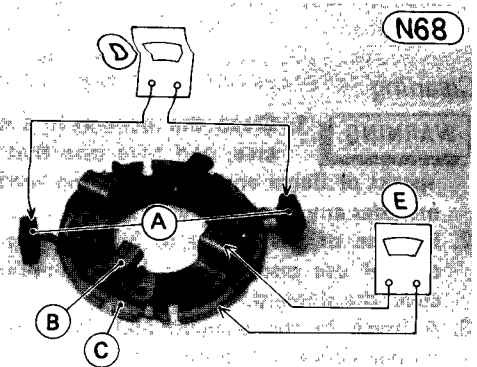

- A. (-) Side Brushes
- B. Brush Holder
- C. Metal Plate
- D. Ohmmeter (x 1 Ω)
- E. Ohmmeter (x 1 kΩ)

- Using the x 1 kΩ ohmmeter range, measure the resistance between each brush holder and the metal plate.
- ★If there is any reading at all, the brush holders have a

312 SUPPLEMENT—1982 MODEL

LIGHTING SYSTEM

Refer to Pgs. 239 – 247, noting the following.

1. For the motorcycle on KZ750H, the brake light failure indicator switch was deleted in the brake light circuit. But, two brake light bulbs are connected in parallel for a safety device. This system is the same as the KZ750E's or L's. Refer to Pgs. 242 – 245.
2. For the other than US and Canadian model motorcycle, the hazard warning system was deleted. There is only the turn signal circuit in the motorcycle.
3. For the motorcycle on KZ750H, the selector switch was deleted in the automatic turn signal cancelling system. So, the turn signal switch is automatically canceled already.

LOW FUEL WARNING SYSTEM (on KZ750H)

The electronic self-checker was added to the low fuel warning system on KZ750H, to check the low fuel warning light bulb. This system is the same as the KZ750E's or L's. Refer to Pg. 278 to servicing this system.

AIR CLEANER ELEMENT (on KZ750R)

Motorcycle on KZ750R uses the oiled type air cleaner element. Refer to Pg. 148, noting the following.

Cleaning

WARNING

1. Clean the element in a well-ventilated area, and take care that there are no sparks or flame anywhere near the working area; this includes any appliance with a pilot light.
 2. Because of the danger of highly flammable liquids, do not use gasoline or a low flash-point solvent to clean the element.
 3. A break in the element material or damage to the sponge gasket will allow dirt and dust to pass through into the carburetor and eventually damage the engine. If any part of the element is damaged, the element must be replaced.
- Remove the air cleaner element.
 - Clean the sponge filter in a bath of a high flash-point solvent, and squeeze it dry.
 - After cleaning, saturate the sponge filter with SE class SAE 30 oil, squeeze out the excess, then wrap it in a clean rag and squeeze it dry as possible. Be careful not

Replacement

Since repeated cleaning opens the pores of the element, replace it in accordance with the Periodic Maintenance Chart.

CARBURETORS (on KZ750R)

Outline:

The carburetors perform the function of mixing the fuel and air in the proportions necessary for good engine performance at varying speeds and loads. In order for them to function satisfactorily, they must be kept well adjusted and maintained.

A linkage mechanism turns each carburetor butterfly valve the same amount in response to throttle grip movement so that the carburetors operate in unison. As the throttle grip is turned counterclockwise, the throttle cable turns the carburetor pulley, which through the linkage mechanism opens the butterfly valves. As the throttle grip is turned clockwise or is released, the return spring closes the butterfly valves.

One of the basic principles in carburetor operation is that the pressure exerted by a moving body of air is less than atmospheric pressure. As the engine draws air in through the carburetor bore, the air pressure in the carburetor bore is less than the air pressure in the float chamber, which is at atmospheric pressure. This difference in air pressure forces the fuel up through the passages into the carburetor bore where it is then atomized by the air, which is flowing at high speed to the engine.

Another important principle is the Venturi Principle, which states that when an air passage narrows, moving air flows faster, exerting even less pressure. For example, at low speeds (0 – ¼ throttle) the vacuum piston is at its lowest position, forming what is called the "primary venturi". Since the engine intake requires less air at lower engine speeds, there would not be enough air flow speed for sufficient fuel to be forced up through the jets unless the passage (carburetor bore) above the jets is constricted. The low position of the vacuum piston constricts this passage so that there will be sufficient air flow speed for pressure difference to force the necessary amount of fuel up through the jet.

The amount of fuel passing through a jet depends both on the size of the jet and on the speed of the air flow over the jet. The speed of this air flow is in turn determined both by the engine rpm and by the dimensions of the passage (varied with the vacuum piston) just above the jet. The size of the jet openings, the various dimensions of the air passages, and the engine rpm are correlated through carburetor design so that, when properly adjusted, the carburetor meters (measures) the fuel and air in the correct proportions at different throttle openings.

The carburetor specifications (Table N14) have been

Table N14 Carburetor Specifications

Type:	Mikuni, BS34
Main Jet:	110
Needle Jet:	Y-9
Jet Needle:	4BE3-3* Ⓢ 4BE04
Pilot Jet:	37.5
Starter Jet:	50
Main Air Jet:	250
Pilot Air Jet:	300

* : The last number is not stamped on the needle, but is the number of the groove in which the clip **must** be installed. The groove numbers are counted from the topmost groove, 5 being the lowest groove.

Ⓢ : US model

CAUTION If the clip is put in any but the specified groove, exhaust emission will be increased, and the engine may suffer serious damage which could result in a crash.

Carburetor trouble can be caused by dirt, wear, maladjustment, or improper fuel level in the float chamber. A dirty or damaged air cleaner can also alter the fuel-to-air ratio.

Table N15 Mixture Trouble Symptoms

Poor running
Overheating
Exhaust smokes excessively
Frequent backfiring in the exhaust system during engine braking

The following explanation of the functioning of the carburetors covers the four main systems for fuel regulation and supply:

- Starter System: Supplies the necessary rich mixture for starting a cold engine.
- Pilot System: Supplies fuel at idling and low speeds.
- Main System: Supplies fuel at medium and high speeds.
- Float System: Maintains the fuel at a constant level in the float chamber.

Starter System:

The starter system provides the exceptionally rich fuel/air ratio that is necessary to enable easy starting when the engine is cold. When starting the engine, the throttle is left closed, and the starter plunger is pulled fully open by pulling out the choke knob. Since the butterfly valve is closed, a high intake vacuum (suction or low pressure) is developed at the engine side of the carburetor bore. The starter plunger, when pulled out, opens up the starter fuel passage and an air passage so that they connect to the engine side of the carburetor bore. As the engine is cranked over, it draws in air through this air passage and fuel from the float chamber through the starter fuel passage. Fuel metered by the starter jet mixes with a small amount of air drawn in through air bleed holes in the starter bleed pipe as it rises in the starter fuel passage. This small amount of air

the plunger chamber where the fuel mixes with the air drawn in through the air passage. Through the mixture passage, this mixture is then drawn into the carburetor bore where it, together with a small amount of mixture supplied by the pilot system, is drawn into the engine.

Starter System

(N69)

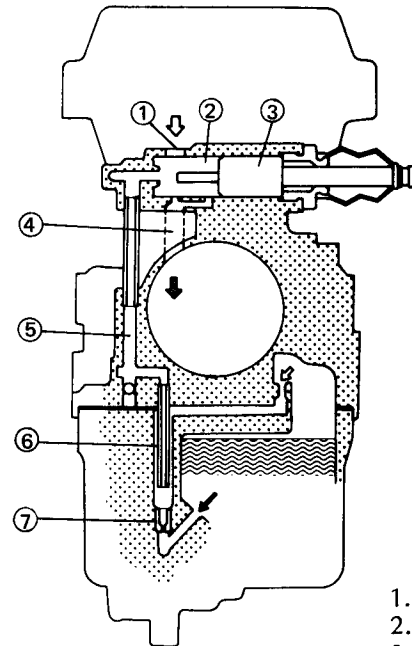

1. Air Passage
2. Plunger Chamber
3. Starter Plunger
4. Mixture Passage
5. Fuel Passage
6. Bleed Pipe
7. Starter Jet

Starter System Fuel and Air Supply

(N70)

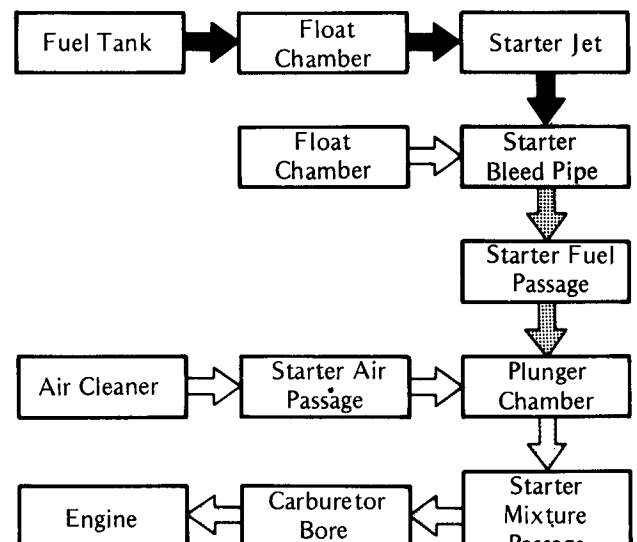

Pilot System:

The pilot system determines the operation of the carburetor from 0 to 1/4 throttle opening. At small throttle openings, almost no fuel is drawn through the main system due to insufficient air flow. Instead, the fuel is drawn through the main and pilot jets as a result of the low pressure (suction) brought about by the demand for air by the engine and the limited but relatively fast flow of air past the pilot outlet. The almost closed position of the butterfly valve restricts the carburetor bore air flow, preventing it from relieving the low pressure created by the engine around the pilot outlet while the Venturi effect (the narrower the air passage, the faster the flow of air) at the engine side of the butterfly valve further reduces the low pressure.

At idling and slightly above, the fuel passes through the main jet, and is then metered at the pilot jet, where the fuel mixes with air metered by the pilot air jet. Then, the fuel passes through the pilot passage, where the pilot screw affects the flow, through the pilot outlet into the carburetor bore, and to the engine. As the

butterfly valve turns a little more, the butterfly valve position extends the low pressure area to the pilot bypass, allowing fuel to bypass part of the pilot passage to go directly to the carburetor bore such that the supply of fuel increases sufficiently with engine need.

Fig. N71 shows throttle opening versus fuel flow for the main and pilot systems. If trouble occurs in the pilot system, not only are starting and low speed running affected, but the transition from pilot to main system is not smooth as the throttle is opened, causing a drop in engine efficiency.

Fuel Flow Characteristic

(N71)

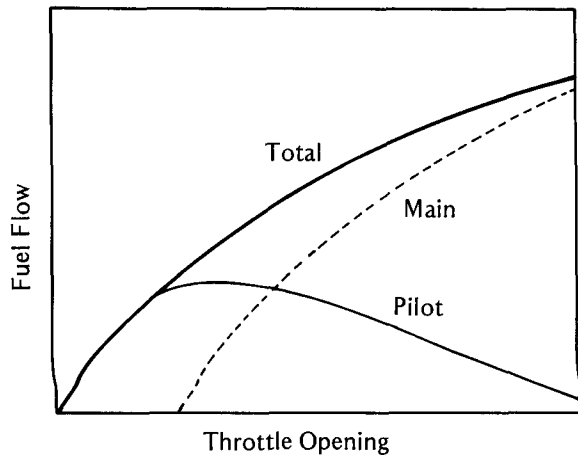

Pilot System

(N73)

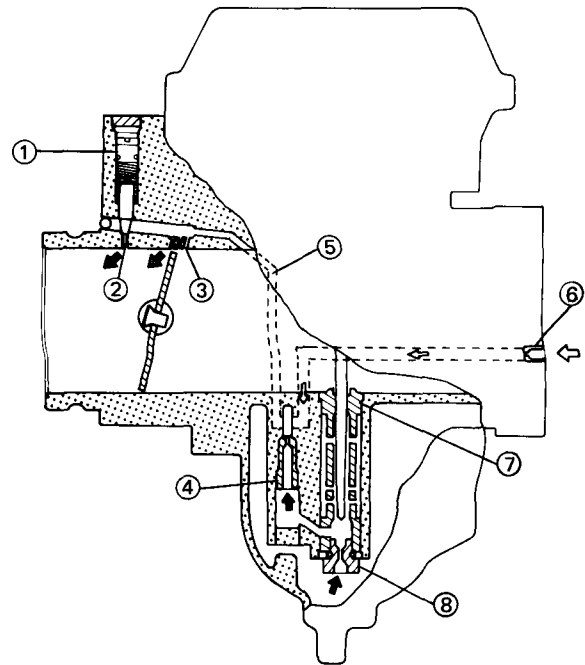

Pilot System Fuel and Air Supply

(N72)

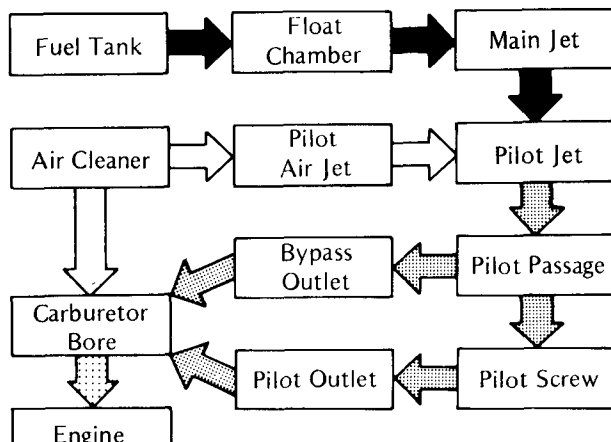

- 1. Pilot Screw
- 2. Pilot Outlet
- 3. Bypass Outlet
- 4. Pilot Jet

- 5. Mixture Passage
- 6. Pilot Air Jet
- 7. Needle Jet
- 8. Main Jet

Main System:

From about ¼ throttle opening, the air flow past the needle jet outlet is sufficient to cause fuel to be drawn through the main system. The fuel passes through the main jet, and then part of it goes through the pilot jet as in the pilot system. The rest of the fuel passes straight up through the needle jet and into the carburetor bore, where it is atomized by the air flow to the engine.

The needle jet has holes to admit the air metered by the main air jet. This air mixes with the fuel in the needle jet to prepare the fuel for better atomization in the carburetor bore.

The lower part of the jet needle is tapered and extends down into the needle jet. It is fixed to the vacuum piston, and thus rises up in the needle jet as the vacuum piston rises. From the time the vacuum piston starts rising, from about ¼ throttle, until it reaches most of the way up in the carburetor bore, the fuel is metered primarily by the main jet and secondarily by the jet needle taper. As the jet needle rises, the needle to jet clearance increases, thereby increasing the amount of fuel that can pass up through the jet.

The vacuum piston is attached to the diaphragm and rises only between ¼ and ¾ throttle. Through the holes in the bottom of the piston, the air pressure in the chamber above the diaphragm is reduced by engine intake vacuum. The air vent maintains atmospheric pressure in the chamber under the diaphragm. As engine speed increases, air pressure in the upper chamber decreases. The difference between this pressure and atmospheric pressure in the lower chamber becomes greater.

The force of the spring and the weight of the piston are overcome, and the piston rises to an extent corresponding to this previbration caused by engine intake pulsing to prevent the vacuum piston from wearing.

As shown in Fig. N74 the quantity of air drawn in by the engine intake is in direct proportion to engine rpm, and the speed of the air flow is constant while the vacuum piston rises from ¼ to ¾ throttle. Were the size of the air passage above the needle jet to change simultaneously with throttle movement rather than with engine intake (demand), the speed of the air flow in the air passage might even drop during a rapid increase in throttle due to the Venturi effect, causing a slight stall in acceleration. However, the vacuum piston-butterfly valve arrangement controls both the air and fuel supply at sudden throttle for smooth and immediate engine response.

At ¾ throttle the vacuum piston reaches its highest position, forming the "secondary venturi" to permit maximum engine output. At near full throttle openings, the cross-sectional area of the needle to jet clearance becomes greater than the cross-sectional area of the main jet. At these openings, the fuel drawn up into the carburetor bore is limited by the size of the main jet rather than the needle to jet clearance.

Venturi Principle

(N74)

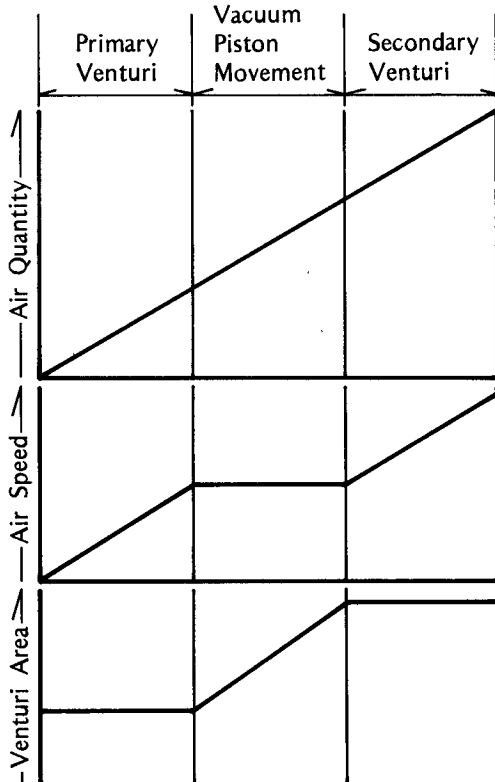

Main System

(N75)

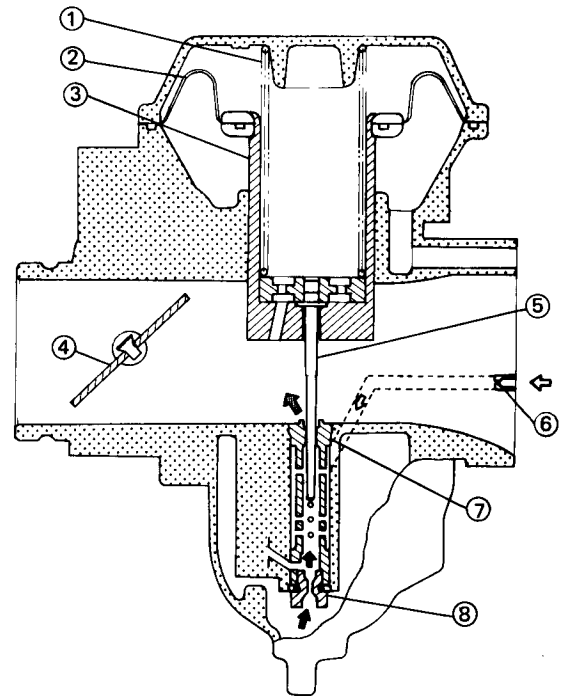

- 1. Spring
- 2. Diaphragm
- 3. Vacuum Piston
- 4. Butterfly Valve
- 5. Jet Needle
- 6. Main Air Jet
- 7. Needle Jet
- 8. Main Jet

316 SUPPLEMENT—1982 MODEL

Main System Fuel and Air Supply

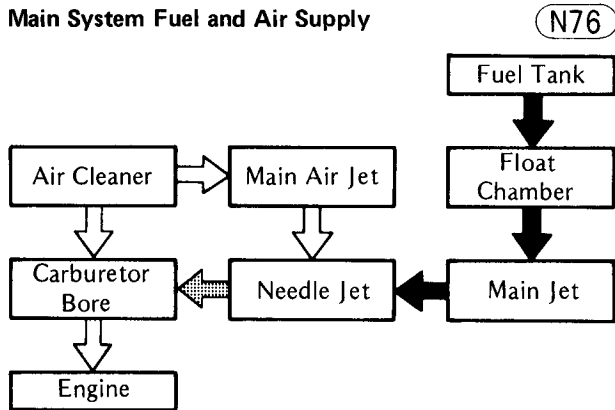

Float System:

The float system serves to keep a more or less fixed level of fuel in the carburetor float chamber at all times so that the fuel mixture to the engine will be stable. If the fuel level in the float chamber is set too low, it will be more difficult for fuel to be drawn up into the carburetor bore, resulting in too lean a mixture. If the level is set too high, the fuel can be drawn up too easily, resulting in too rich a mixture.

The fuel level is defined as the vertical distance from the center of the carburetor bore to the surface of the fuel in the float chamber. The fuel level is maintained at a constant value by the action of the float valve, which opens and closes according to the fuel level. As fuel flows through the float valve into the chamber, the fuel level rises. The float, rising with the fuel level, pushes up on the valve needle. When the fuel reaches a certain level, the valve needle is pushed completely into the valve seat, which closes the valve so that no more fuel may enter the chamber. As the fuel is drawn up out of the float chamber, the fuel level drops, lowering the float. The needle no longer blocks the float valve, and fuel once again flows through the float valve into the chamber.

Float System

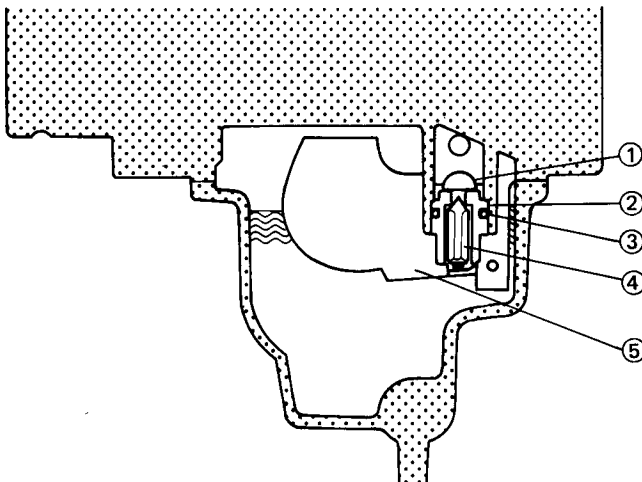

- | | |
|---------------|-----------------|
| 1. Filter | 4. Valve Needle |
| 2. Valve Seat | 5. Float |

NOTE: It is impractical to measure the actual design fuel level. Service fuel level is defined as the vertical distance from the bottom edge of the carburetor body to the surface of the fuel in the float chamber. Measuring the service fuel level is an indirect method of inspecting for correct design fuel level.

Inspection:

WARNING Gasoline is extremely flammable and can be explosive under certain conditions. Turn the ignition switch OFF. Do not smoke. Make sure that area is well ventilated and free from any source of flame or sparks, this includes any appliance with a pilot light.

Inspection

- Inspect the float for damage.
- ★ If it is damaged, replace it.
- Check the float valve for wear.
- ★ If the needle is worn as shown in the diagram, replace the valve needle and valve seat as a set.
- Push the rod in the valve needle, then replace it.
- ★ If the rod does not come out fully by spring tension, replace the valve needle and valve seat as a set.

Valve Needle

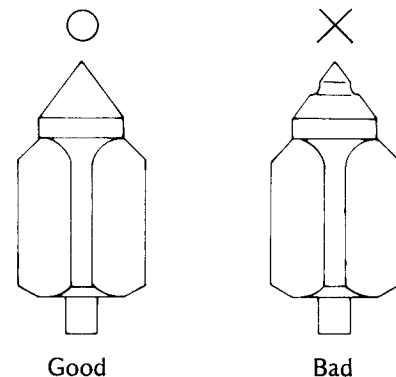

- Remove the pilot screw, and check that the tapered portion of the pilot screw is not worn or otherwise deformed.
- ★ If it is, replace the screw.

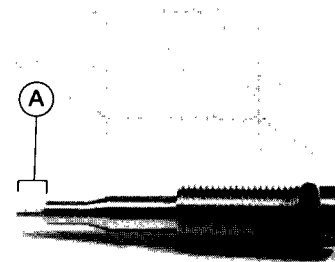

- Check the jet needle and needle jet.
- ★A worn needle jet and jet needle should be replaced.
- Visually inspect the diaphragms of the vacuum pistons.
- ★If there is any damage, the diaphragm should be replaced.

Service Fuel Level Measurement

If the motorcycle exhibits symptoms of improper fuel mixture, measure the service fuel level.

- Remove the carburetors, and hold them in a true vertical position on a stand.
- Put the fuel tank on a bench, and connect the fuel tap to the carburetors using a suitable hose.
- Prepare a hose (6 mm in diameter and about 300 mm long).
- Connect one end of the hose with the carburetor float bowl, and insert the other end into the fuel level gauge (special tool).
- Holding the gauge against the side of the carburetor body so that "0" line is several millimeters higher than the bottom edge of the carburetor body, turn the fuel tap lever to the "PRI" position and turn out the carburetor drain plug 1 – 2 turns to feed fuel to the carburetor and gauge.
- Wait until the fuel level in the gauge settles.
- Keeping the fuel level gauge vertical, slowly lower the gauge until the "0" line is even with the bottom edge of the carburetor body.

NOTE: Do not lower the "0" line below the bottom edge of the carburetor body. If the gauge is lowered and then moved upwards, the fuel level measured shows somewhat higher than the actual fuel level, necessitating to repeat the measurement from the beginning.

- Read the service fuel level in the gauge.

Table N16 Service Fuel Level

Standard:	3 ± 1 mm below from bottom edge of carburetor body to fuel level
-----------	--

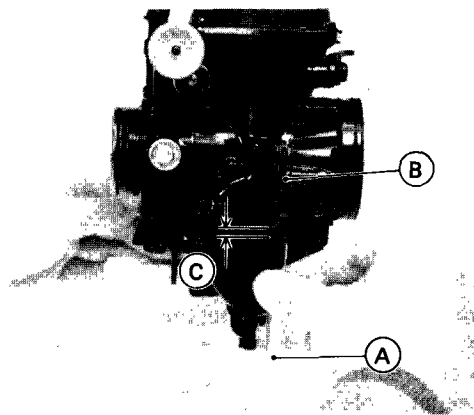

N80

A. Hose
B. Fuel Level Gauge: 57001 –1017
C. Service Fuel Level

- Tighten the drain plug, and remove the gauge and hose.
- Measure the fuel level in the other carburetors in the

- Turn the fuel tap lever to the "ON" position to shut off the tap.
- ★If the fuel level is incorrect, adjust it.

Service Fuel Level Adjustment

- Drain all carburetors, and remove the float bowls and gaskets.
- Put the carburetors upside down on the working bench, and measure the float height of each carburetor. Take measurements for both floats in each carburetor.

NOTE: Float height is the vertical distance from the float bowl mating surface of the carburetor body to the top of the float.

Table N17 Float Height

Float Height:	18.6 mm
---------------	---------

Measuring Float Height – Mikuni Carburetors N81

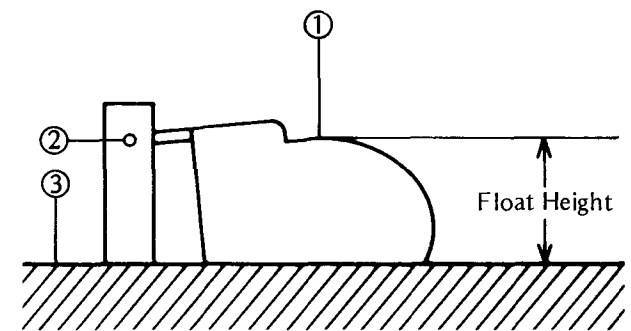

- 1. Float
- 2. Float Pin
- 3. Float Bowl Mating Surface

★If the float height is significantly below or over the specified value, adjust it as follows.

- Tap out the float pin, and remove the float and the valve needle.
- Check the valve needle and the valve seat for wear.
- ★If they are worn, replace them as an assembly.
- Bend the tang on the float a very slight amount to change the float height. Increasing the float height lowers the fuel level, and decreasing the float height raise the fuel level.

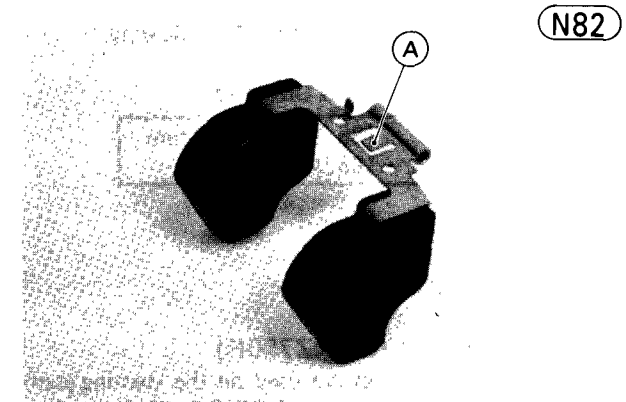

N82

318 SUPPLEMENT-1982 MODEL

- After adjustment, assemble the carburetors, and measure the service fuel level again. Readjust if necessary.
- ★If the service fuel level cannot be corrected by adjusting the float height within the specified range, the float may be damaged necessitating float replacement.

CYLINDER HEAD (on KZ750R)

Refer to Pgs. 160 – 161, 275, noting the following.

Table N18 Combustion Chamber Volume

Standard:	24.9 ± 0.4 cc
-----------	---------------

PISTON, PISTON RINGS (on KZ750R)

Refer to Pgs. 168 – 172, noting the following.

Table N19 Piston Ring Thickness

Top Ring	
Standard:	0.970 – 0.990 mm
Service Limit:	0.90 mm
Second Ring	
Standard:	1.179 – 1.190 mm
Service Limit:	1.10 mm

Table N20 Piston Ring Groove Width

Top Ring	
Standard:	1.02 – 1.04 mm
Service Limit:	1.12 mm
Second Ring	
Standard:	1.21 – 1.23 mm
Service Limit:	1.31 mm

SPROCKETS (on KZ750R)

Refer to Pgs. 199 – 200, noting the following.

Table N21 Rear Sprocket Diameter

Standard :	188.32 – 188.82 mm
Service Limit:	188.0 mm

STEERING STEM (on KZ750R)

Tapered roller bearings are used on the steering stem bearings for the motorcycle on KZ750R. Refer to Pre

Steering Stem Bearing Lubrication

In accordance with the Periodic Maintenance Chart, the steering stem bearings should be relubricated.

- Remove the steering stem.
- Using a high flash-point solvent, wash the upper and lower tapered roller bearings in the cages, and wipe the upper and lower outer races, which are press-fitted into the frame head pipe, clean of grease and dirt.
- Visually check the outer races and the rollers.
- ★Replace the bearing assembly if they show wear or damage.
- Pack the upper and lower tapered roller bearings in the cages with grease, and apply light coat of grease to the upper and lower outer races.

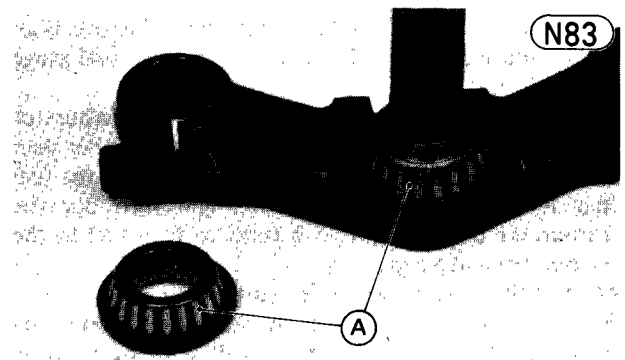

A. Steering Stem Bearings

- Install the steering stem, and adjust the steering.

Bearing Wear, Damage

- Using a high flash-point solvent, wash the upper and lower tapered rollers in the cages, and wipe the upper and lower outer races, which are press-fitted into the frame head pipe, clean of grease and dirt.
- Visually check the outer races and the rollers.
- ★Replace the bearing assembly if they show damage.

Grease Seal Deterioration, Damage

- Inspect the grease seal on the upper tapered roller bearing for any signs of deterioration or damage.
- ★Replace the bearing if necessary.

FRONT FORK (on KZ750R)

Refer to Pgs. 209 – 213, noting the following.

1. A hole in each fork leg just below the steering stem head is covered and sealed by the connecting bracket. A groove and hole in the connecting bracket leads to the connecting hose. Thus, the air chambers in the two fork legs and connected by the connecting hose and under equal pressure.
2. When removing the fork top plug to change the fork oil, the handlebar holder on its fork leg must be removed from the top of the leg.

Table N22 Fork Oil (each fork leg)

Viscosity :	SAE 10W
Amount of oil	
When changing oil:	About 240 cc
After disassembly and completely dry:	256 ± 4 cc
*Oil Level :	168 ± 4 mm

*Distance from the top of the inner tube, measured with the fork fully compressed and with the main spring removed.

Table N23 Fork Spring Free Length

Standard :	506.5 mm
Service Limit :	496 mm

Fork Spring Force (KZ750R)

(N84)

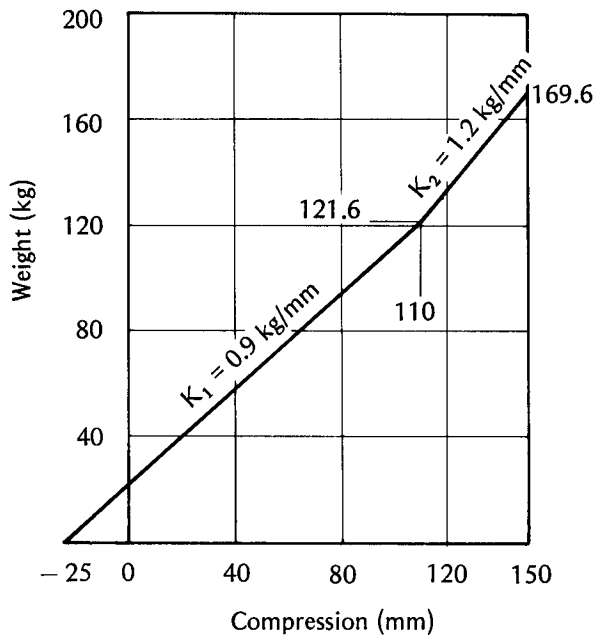

TACHO/VOLTMETER (on KZ750R)
Outline:

The motorcycle on KZ750R has an electrically operated, combined tacho/voltmeter. When the TACHO/VOLT switch is not pushed, the combined meter indicates the engine rotational speed. The combined meter shows the battery voltage only when the TACHO/VOLT switch is pushed down.

The combined meter contains two circuits, one is the tachometer drive circuit and the other is the voltmeter drive circuit. The pointer and rotating coil is the

Usually the rotating coil is connected to the tachometer drive circuit. When the TACHO/VOLT switch is pushed down, the rotating coil is switched over to the voltmeter drive circuit and the pointer indicates the battery voltage.

Tacho/voltmeter

(N85)

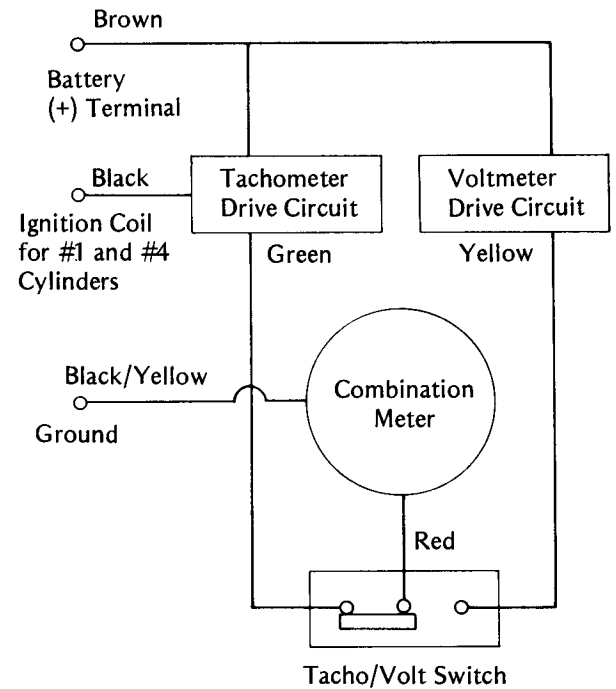

The pointer drive mechanism for the combined meter is basically the same as that for ordinary ammeters, that is, D'Arsonval type or a permanent-magnet movable coil type.

Engine rotational speed is picked up at the primary winding lead from one of the ignition coils. The pulses sent from the ignition coil primary winding lead are changed to smooth direct current by the tachometer drive circuit. The intensity of the direct current is in proportion to the frequency of the original pulses.

D'Arsonval Type Meter

(N86)

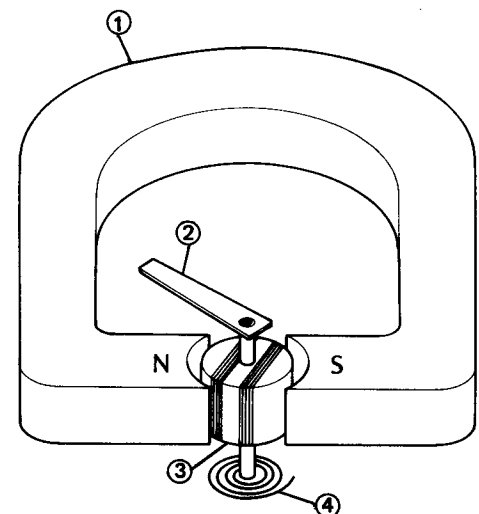

1. Permanent Magnet

3. Rotating Coil

Tacho/Voltmeter Troubleshooting Guide:

If trouble is suspected in the tacho/voltmeter system, check the system using two test charts. One chart is titled "Tachometer Test," and the other "Voltmeter Test." Test procedures in the charts are explained individually below. When one of the two meters is malfunctioning, follow the appropriate test chart. If neither meter does not operate correctly, first test the tachometer, and then test the voltmeter.

- NOTE:** 1. The Tacho/Voltmeter Troubleshooting Guide is explained on the assumption that the ignition system operates normally.
2. The tacho/voltmeter connector (white, 9-pin) is under the fuel tank.
 3. Remove the fairing, headlight, and meter assembly bottom cover before starting troubleshooting.
 4. If the inspection proves that the combined meter system is good, but the system still shows trouble while riding; test the system while the engine is running. Trouble may be caused from engine vibration.

Test No. 1 Meter Mounting Inspection

- Check to see that the rubber dampers(4) at the meter mounting bracket is in good conditions; they should not harden or cracked.
- Replace any damaged rubber dampers with new ones.
- Check to see that all meter mounting bolts, nuts, and screws are tightened securely.
- ★Tighten the loose fasteners.

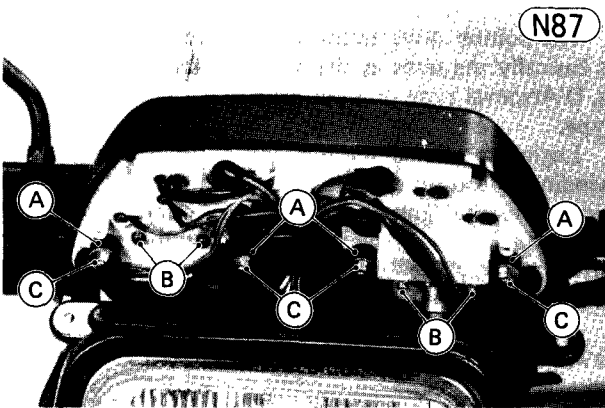

A. Rubber Dampers **C. Mounting Nuts**
B. Mounting Screws

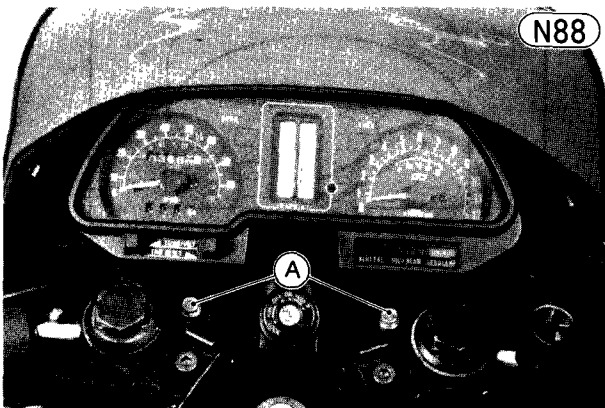

Test No.2 Meter Power Supply Test

- Use the voltmeter as shown in the table to check that the meter is powered by the battery.
- Turn on the ignition switch, and measure the lead voltage.
- ★If the meter does not show battery voltage, the battery power does not reach the meter.

Table N24 Meter Power Supply

Meter Range	Connections	Reading (Criteria)
25 V DC	○Meter (+) → Brown lead ○Meter (-) → Black/yellow lead	Battery Voltage

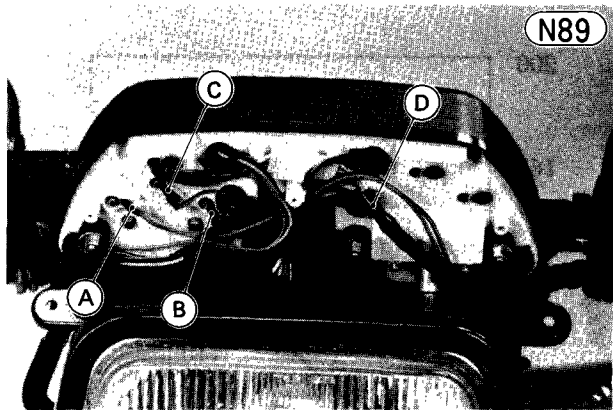

A. Brown Lead **C. Black/Yellow Lead**
B. Black Lead **D. Switch Leads**

Test No. 3 Engine Speed Signal Test

- Use the voltmeter as shown in the table to check the engine speed signal is sent to the meter.
- Turn on the ignition switch, and read the voltmeter.
- Start the engine, and read the voltmeter.
- ★If the meter does not show the voltage shown in the table, the signal does not reach the meter.

Table N25 Engine Speed Signal

Meter Range	Connections	Reading
10V DC	○Meter (+) → Brown lead ○Meter (-) → Black lead	○0 V when engine is stopped. ○2 – 4 V when engine is running.

Test No. 4 Switch-Over Switch Test

- Disconnect the three switch-over switch leads (green, red, and yellow).
- Use the ohmmeter to check the conductivity between two leads at a time (3 possible combinations).
- ★If any two leads do not show the conductivity between them...

Table N26 Switch-Over Switch Connections

	Green	Red	Yellow
Release	●————●		
Push		●————●	

Tachometer Test

N90

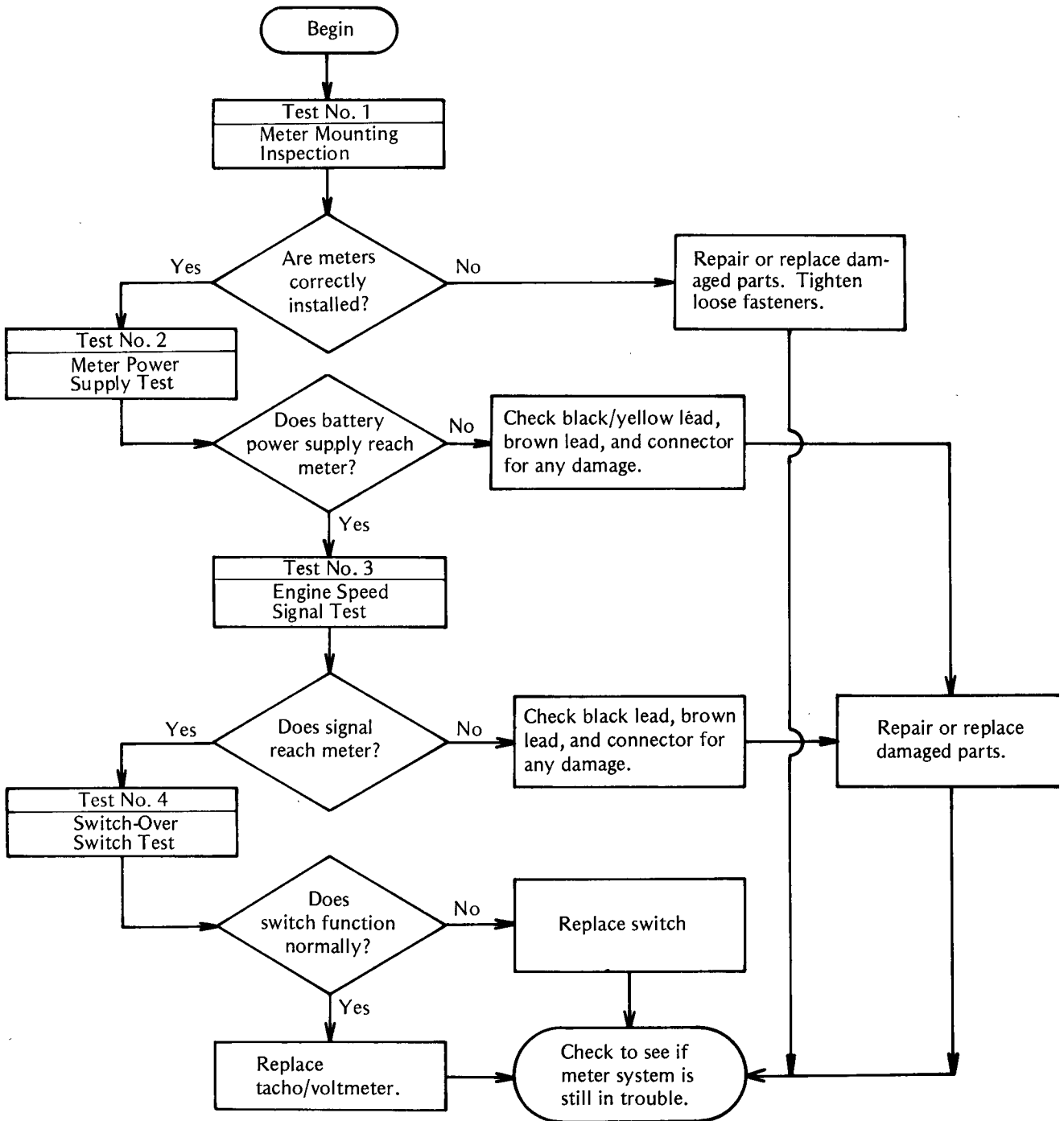

Voltmeter Test

N91

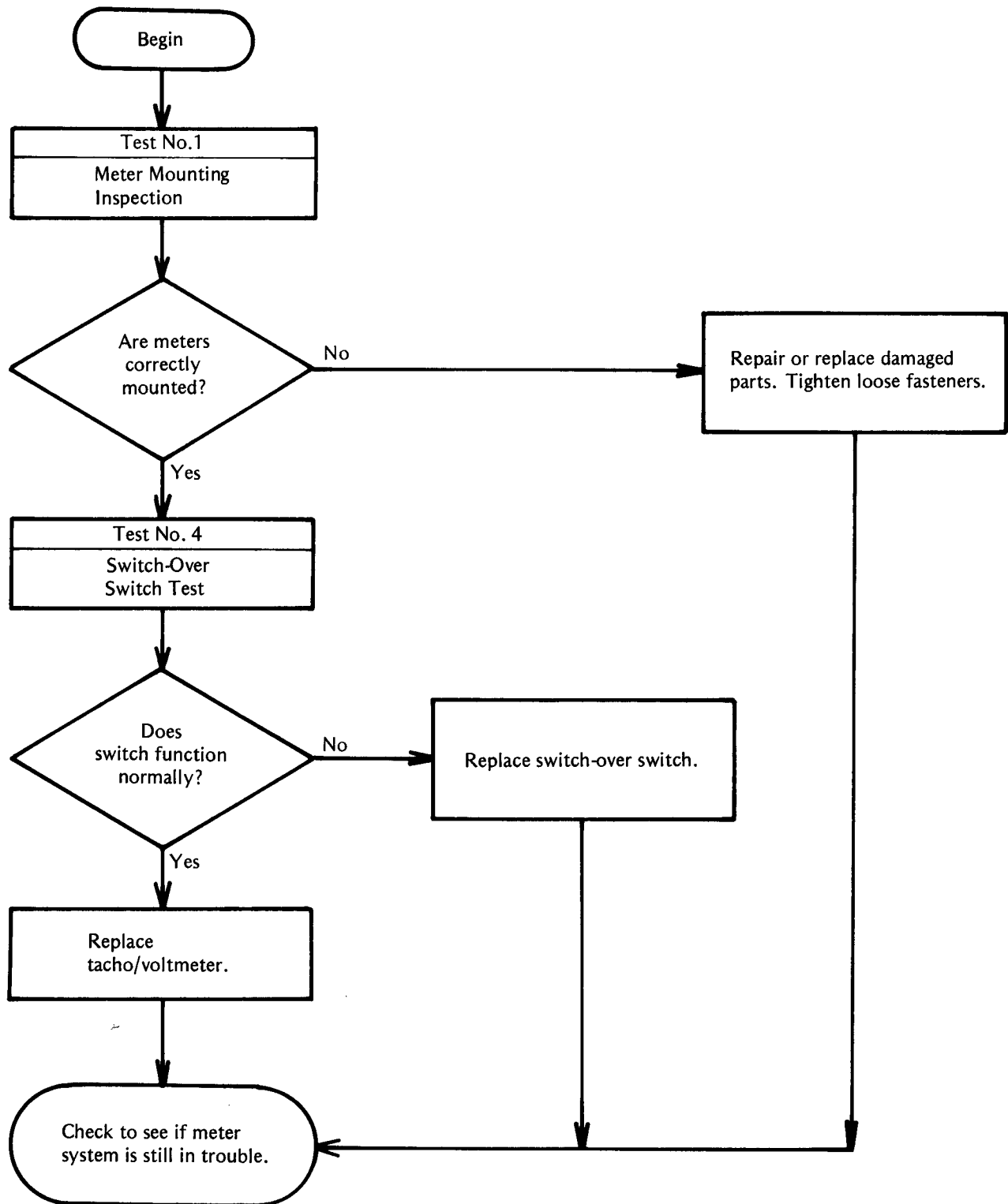

**LCD FUEL GAUGE AND WARNER UNIT
(on KZ750R)**

Outline:

When the ignition switch is on, the computerized gauge and warning system monitors the information provided to it by the sensors. If the computer detects a problem; the appropriate LCD (Liquid Crystal Display) appears on the warning panel, and the red warning light begins flashing.

Each LCD warner and gauge works as described below:

- STAND, ENG. SW. (Side Stand Warning): This red LCD warner consists of two segments, upper and lower halves. When the side stand is down or when the engine stop switch is turned to the OFF position, this warner warns the rider by flashing.
- OIL (Engine Oil Level Warning): This red LCD warner consists of two segments, upper and lower halves. When the oil level in the engine becomes lower than the predetermined level, this warner warns the rider by flashing.
- BATT (Battery Electrolyte Level Warning): This red LCD warner consists of two segments, upper and lower halves. When the battery electrolyte level becomes lower than the predetermined level, this warner warns the rider by flashing.

○Fuel Gauge and Low Fuel Warning: This black LCD gauge and warner consists of nine segments in a row. When the fuel tank is full, and the segments appear. As the fuel level in the tank goes down, segments disappear one by one from the topmost segment. When the fuel level becomes lower than the predetermined level, the bottom segment begins flashing.

○Warning Light: This red LED (Light Emitting Diode) warning light flashes when any one of the above warners flashes.

Every time the ignition switch is turned on, the computer in the unit checks the LCD and warning light for damage. The checking procedures are:

1. The nine fuel gauge segments appear one by one from the bottom to the top, and stay on.
2. The six segments of BATT, OIL, and STAND ENG. SW. Warners appear one by one from the bottom to the top, and stay on.
3. The red warning light goes on for about one second to show the end of the checking procedure.

During checking procedures, all LCD segments and red warning light should light. After checking procedure is completed, the computer begins monitoring the condition of the motorcycle.

The gauge and warning system consists of an LCD gauge-and-warner unit, an oil level sensor, a fuel level sensor, a side stand switch, and an electrolyte level sensor.

Gauge and Warning System Wiring Diagram

(N92)

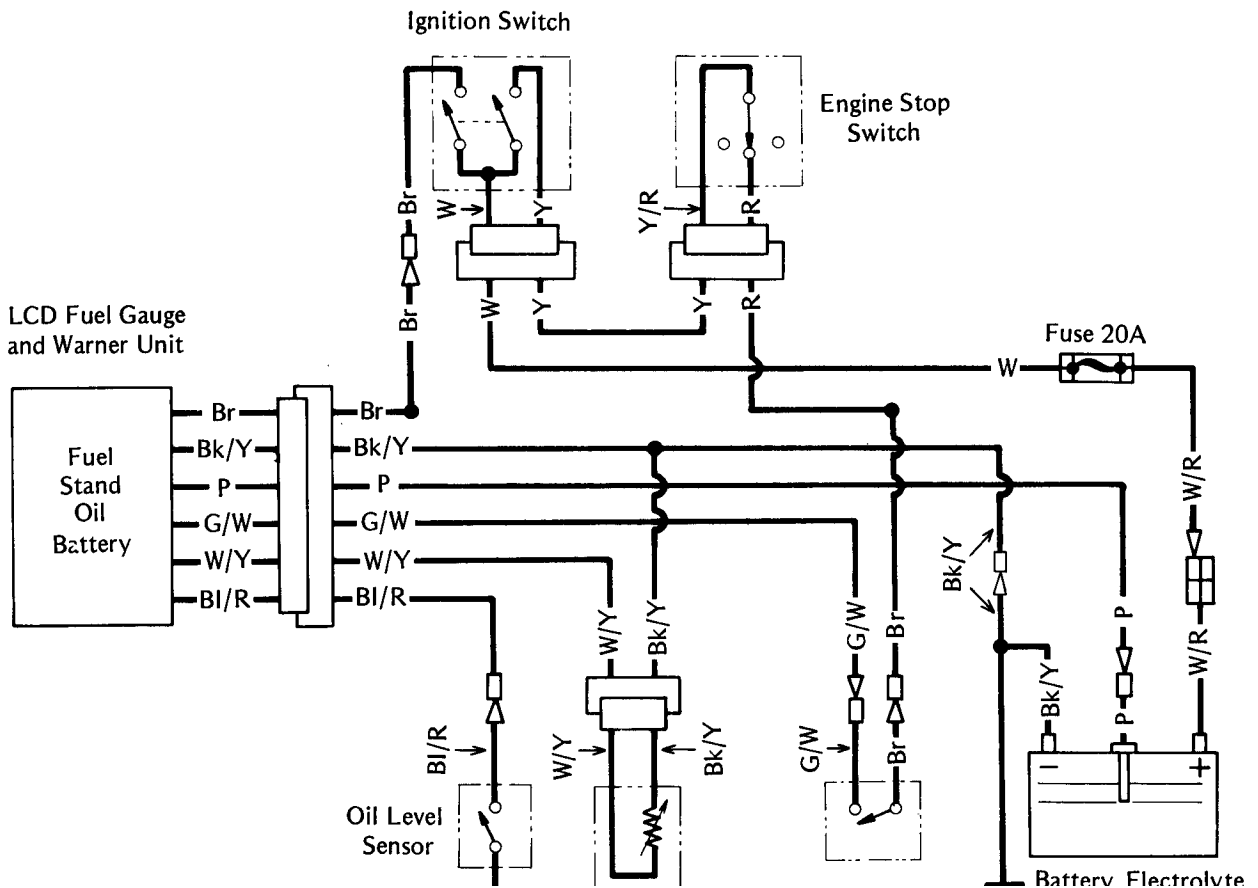

324 SUPPLEMENT—1982 MODEL

Gauge and Warning System Troubleshooting:

Test in this section include the following:

1. Quick Initial Check
2. Power Supply Test
3. Gauge and Warner Unit Test
4. Wiring and Connector Test
5. Sensor Test
 - a. Side Stand Switch Test
 - b. Oil Level Sensor Test
 - c. Battery Electrolyte Level Sensor Test
 - d. Fuel Level Sensor Test

NOTE: If all the tests prove that the gauge and warning system is good, but the system still shows trouble while riding; test the system with the engine running. Trouble may result from engine vibration.

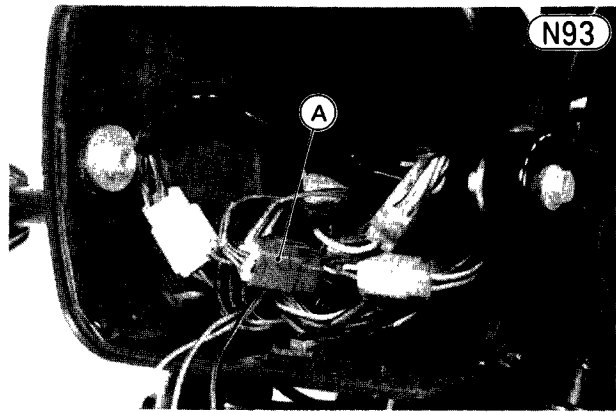

A. Red 6-pin Connector

Test No. 1 Quick Initial Check

Give the system a quick initial check before starting a series of time consuming tests, or worse yet, removing parts for repair or replacement. Such a check will often turn up the source of the trouble.

- Turn off and turn on the ignition switch to observe one-by-one display on the LCD panel during self-checking procedure.
- ★ If the self-checking procedure does not begin at all, the battery power may not reach the gauge and warner unit. Proceed to the "Test No. 2 Power Supply Test."
- ★ If the self-checking procedure is performed normally, the battery power is supplied to the unit, and the unit works properly. The trouble is caused by wirings and/or sensors. Proceed to the "Test No. 4 Wiring and Connector Test."
- ★ If some of the LCD segments and/or red warning light do not appear or do not go on, the gauge and warner unit is damaged necessitating unit replacement.

Test No. 2 Power Supply Test

- Turn off the ignition switch.
- Set the multimeter to the 25V DC range.
- Disconnect the gauge and warner unit connector (red, 6-pin), and connect the multimeter to the connector as shown in the table to measure the voltage.
- ★ If the meter does not show the voltage indicated in the table, inspect the brown wire, black/yellow wire, and connectors for damage. Repair or replace the damaged wire or connector.
- ★ If the gauge and warner unit is powered by the battery but does not work properly, continue with the "Test No. 3 Gauge and Warner Unit Test."

Table N27 Power Supply Test

Meter Range	Connections	Meter Reading (Criteria)
25 V	○ Meter (+) → Brown wire	○ 0 V when ignition switch is off.
DC	○ Meter (-) →	○ Battery voltage when

Test No. 3 Gauge and Warner Unit Test

- Prepare six auxiliary wires, two supply battery power to the unit and four to simulate the sensors.
- Disconnect the gauge and warner unit connector (red, 6-pin).
- Connect the four sensor simulating wires to the terminals in the connector as shown in the table.
- Using two wires to supply battery power to the unit, connect the brown terminal in the connector with the battery positive (+) terminal and connect the black/yellow terminal in the connector with the battery negative (-) terminal.

Table N28 Gauge and Warner Unit Test

Circuit	Connections
Side Stand Warner	○ Green/white lead → Battery (+)
Oil Level Warner	○ Blue/red lead → Battery (-)
Battery Electrolyte Level Warner	○ Pink lead → Battery (+)
Fuel Gauge and Low Fuel Warner	○ White/yellow lead → Battery (-)

- ★ When the unit is connected to the battery; the self-checking procedure should start. After the procedure is completed, the gauge and warner display should be as shown in the figure (a). If the self-checking procedure did not start, or if there is any fault on the display; replace the gauge and warner unit.
- Disconnect one of the sensor simulating wires from the connector.
- ★ If both the LCD warner and the red warner light flash as shown in the figure (b), the unit works properly. Proceed to the "Test No.4 Wiring and Connector Test." If any of them does not flash or turns on without

Gauge and Warner Unit Test

(a) All sensor simulating wires are connected.

(b) Sensor simulating wires are disconnected.

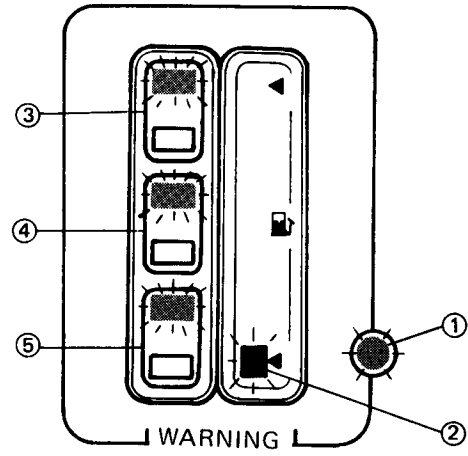
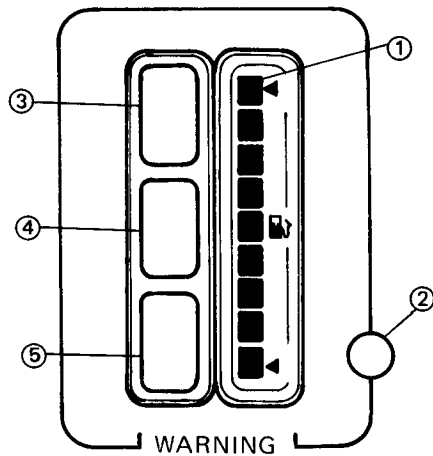

1. Fuel Gauge: Nine segments appear.
2. Warning Light: Unlits.
3. Side Stand Warner: Does not appear.
4. Oil Level Warner: Does not appear.
5. Battery Electrolyte Level Warner: Does not appear.

1. Warning Light: Flashes when any one of simulating Wires is disconnected.
- *2. Fuel Warner: Flashes when white/yellow wire is disconnected.
3. Side Stand Warner: Flashes when green/white wire is disconnected.
4. Oil Level Warner: Flashes when blue/red wire is disconnected.
5. Battery Electrolyte Level Warner: Flashes when pink wire is disconnected.

*The time delay circuit is provided in the fuel gauge circuit to stabilize the gauge display. It takes 3 to 12 seconds for each segment to disappear or appear. Also it takes 3 to 7 seconds for the bottom segment to begin or stop flashing.

Test No. 4 Wiring and Connector Test

- Set the motorcycle on the center stand.
- Disconnect the gauge and warner unit connector (red, 6-pin).
- Connect the multimeter to the wire in the disconnected

female connector (main wiring harness side connector) as indicated in the table and read the meter. Turn on the ignition switch when testing the side stand warner wire, and make sure the engine stop switch is in the RUN position.

Table N29 Wiring and Connector Test

Wire	Meter Range	Connections	Meter Reading (Criteria)
Side stand warner	25V DC	○Meter (+) → Green/white wire ○Meter (-) → Black/yellow wire	○Battery voltage when side stand is up. ○0 V when side stand is down.
Oil level warner	x 10 Ω	○One meter lead → Blue/red wire ○Other meter lead → Black/yellow wire	○Less than 0.5 Ω when engine oil level is higher than "lower level line" next to the oil level gauge. ○∞ Ω when engine oil level is much lower than the "lower level line".
Battery electrolyte level warner	10V DC	○Meter (+) → Pink wire ○Meter (-) → Black/yellow wire	○More than 6 V when electrolyte level is higher than "lower level line". ○0 V when electrolyte level is lower than "lower level line".
Fuel gauge and low fuel warner	x 10 Ω	○One meter lead → White/yellow wire ○Other meter lead → Black/yellow	○1 - 117 Ω

326 SUPPLEMENT—1982 MODEL

★If the multimeter does not read as shown in the table, first inspect the related wire(s) and connector(s), then repair or replace the damaged part(s). If the wire(s) and connector(s) prove good, proceed to the "Test No. 5 Sinsor Test."

Test No. 5 Sensor Test

(a) Side Stand Switch Test:

- Turn off the ignition switch, and disconnect the side stand switch leads.

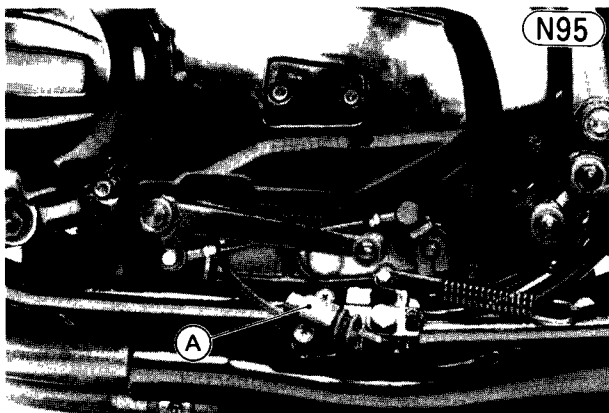

A. Side Stand Switch

NOTE: For West Germany, UK, Norway, Switzerland, and Sweden, the side stand switch is located the rear side of the side stand, and connects to the stand with the spring.

WARNING

For Countries listed above, before putting the motorcycle up on its side stand, make sure that the side stand is placed in the full forward position. If this is done carelessly, the motorcycle may move forward, causing the motorcycle to fall over.

- Set the multimeter to the $\times 1 \Omega$ range, and connect the meter between the switch leads as indicated in the table to check the switch operation.

★If the meter does not read as indicated in the table, check to see that the side stand switch is properly installed on the frame. If the switch is not correctly installed, re-mount it correctly. If the switch is correctly mounted, replace the side stand switch.

Table N30 Side Stand Switch Operation

Meter Range	Connections	Meter Reading (Criteria)
$\times 1 \Omega$	For West Germany, UK, Norway, Switzerland, and Sweden: ○One meter lead → Red switch lead ○Other meter lead → Green/white switch lead	$\infty \Omega$ when the side stand is in the position ① or ③ (fig. N96) $\infty \Omega$ when the side stand is in the position ②.
	For Countries other than above: ○One meter lead → Brown switch lead	$\infty \Omega$ when the side stand is up (position ③ in fig. N96). $\infty \Omega$ when the side stand is down (positions ① and ②)

Side Stand Position

N96

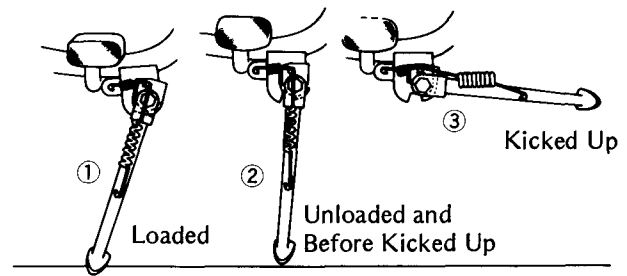

(b) Oil Level Sensor Test:

- Drain the engine oil, and remove the oil level sensor.
- Connect the multimeter set to the $\times 1 \Omega$ range as shown in the table to check the sensor continuity.
- ★The meter should read as shown in the table. If it does not, replace the oil level sensor.

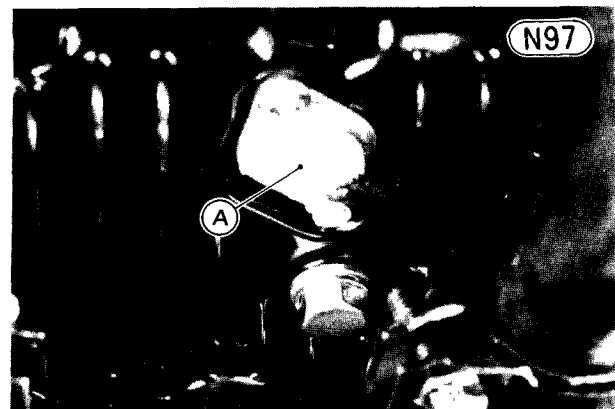

A. Oil Level Sensor

Table N31 Oil Level Sensor Test

Meter Range	Connections	Meter Reading (Criteria)
$\times 1 \Omega$	○One meter lead → Sensor lead ○Other meter lead → Sensor body	$\infty \Omega$ when sensor is held upright. ○Less than 0.5Ω when sensor is held upside down.

(c) Battery Electrolyte Level Sensor Test:

- Remove the seat and disconnect the sensor pink lead.
- Connect the multimeter set to the 10V DC range as shown in the table to check the sensor lead voltage.
- If the voltage is lower than the value in the table, first check the sensor is in the correct position. The correct position of the sensor is indicated with the arrow mark.
- ★ If the sensor is in the incorrect position, re-install the sensor to the correct position, and check the sensor lead voltage again.

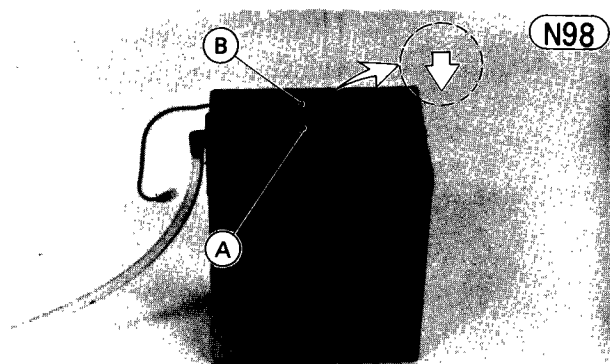

A. Battery Electrolyte Level Sensor B. Arrow Mark

- If the voltage is lower than the value in the table, check the electrolyte level in the cell where the sensor is installed.
- ★ If the level is lower than the lower level line, add distilled water.
- ★ If the level is high enough, remove the sensor from the battery to check for an open lead and to check the sensor lead stick for corrosion or other damage. If any trouble is found in the lead or stick, repair or replace it.

(d) Fuel Level Sensor Test:

- Drain the fuel tank, and remove the tank.
- Remove the fuel level sensor, and check that the float moves up and down smoothly without binding. It should go down under its own weight.
- ★ If the float does not move smoothly, replace the sensor.

Table N32 Battery Electrolyte Level Sensor Test

Meter Range	Connections	Criteria	Inspection Items when out of Criteria
10V DC	<ul style="list-style-type: none"> ○ Meter (+) → Sensor lead ○ Meter (-) → Chassis ground 	<ul style="list-style-type: none"> ○ More than 6V 	<ul style="list-style-type: none"> ○ Sensor Position ○ Electrolyte level in cell in which sensor is installed. ○ Sensor lead

Fuel Level Sensor

N99

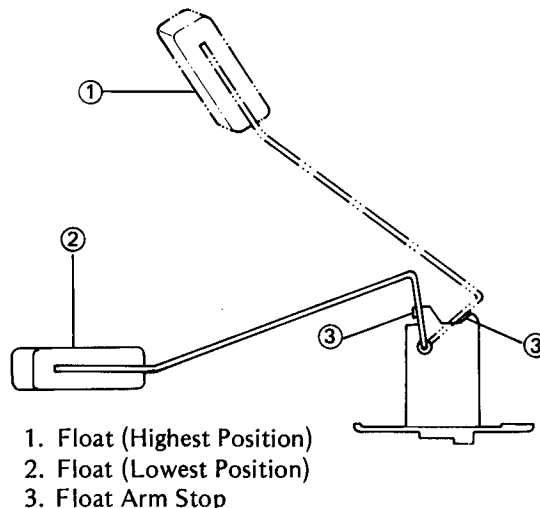

- Measure the resistance of the fuel level sensor with an ohmmeter.
- ★ If the ohmmeter does not show the values in the table, or the reading does not vary smoothly as the fuel level changes, replace the sensor.

Table N33 Resistance of Fuel Level Sensor

Tank (Float)	Resistance
Full (Highest position)	1 – 5 Ω
Empty (Lowest position)	103 – 117 Ω

- Inspect the leads and 2-pin connector.
- ★ If they show any damage, replace the sensor.

Appendix

ADDITIONAL CONSIDERATIONS FOR RACING (on KZ750R)

Jet Needle

N100

Refer to Pgs. 256 – 257, noting the following.

Carburetors:

For the KZ750R other than the US model, a certain amount of adjustment can be made by changing the position of the needle. There are five grooves at the top of the needle. Changing the position of the clip to a groove closer to the bottom raises the needle, which makes the mixture richer at a given position of the throttle valve.

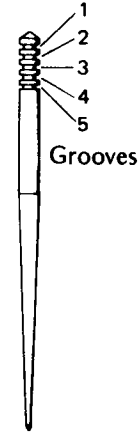

SPECIAL TOOLS

1. The following special tool is newly available now for the all models.
○Reference Nos. 1 and 2
2. For servicing the KZ750R, the special tools listed on Pgs. 258 – 262, 279 – 280, must be necessary, and also the following special tools must be necessary additionally.
○Reference Nos. 3 – 7

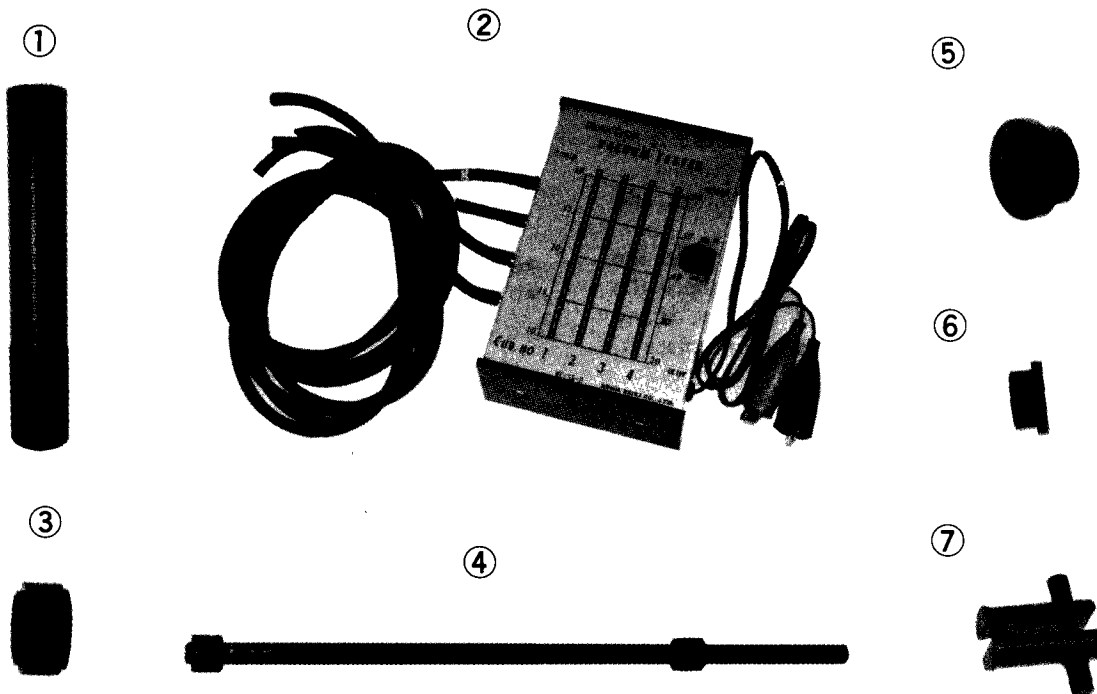

Ref. No.	New Part No.	Part Name	Q'ty	Old Part No.
1	57001 – 382	Driver	1	57001 – 380
2	57001 – 1152	Vacuum Tester	1	57001 – 127
3	57001 – 1074	Adapter-use with 57001 – 137	1	—
4	57001 – 1075	Driver Press Shaft	1	—
5	57001 – 1076	Driver-use with 57001 – 1075	1	—
6	57001 – 1106	Driver-use with 57001 – 1075	1	—
—	—	—	—	—

Supplement for 1983 Model

“NOTE”

- *The service informations for the 1983 ZX750A are newly included in this section. Unless otherwise noted, refer to the informations for the following 1982 models.
KZ/Z750-R1 for ZX750-A1*
- *Unless otherwise noted, refer to the informations for the following 1982 models to service the 1983 KZ/Z750L.
KZ/Z750-R1 for KZ/Z750-L3*
- *See the service data (p. 358 – 365) when servicing the 1983 models.*

Table of Contents

Safety Awareness	336	Front Fork (ZX750A)	351
List of Abbreviations	336	Rear Shock Absorber (ZX750A)	351
Unit Conversion Table	337	Swing Arm (ZX750A)	351
Model Identification	338	Uni-Trak Links (ZX750A).	351
Specifications		Junction Box (ZX750A).	351
Specifications (KZ750H and KZ/Z750L)	339	Maintenance	
Specifications (ZX750A)	342	Service Data	351
Periodic Maintenance Chart	345	Air Cleaner Element (KZ750H)	361
Adjustment		Carburetors (KZ750H)	361
Clutch (ZX750A)	346	Disc Brakes (ZX750A)	361
Front Fork (ZX750A)	346	Front Fork (ZX750A)	361
Rear Shock Absorber (ZX750A)	346	Rear Shock Absorbers (KZ/Z750L)	361
Drive Chain (ZX750A)	347	Rear Shock Absorber (ZX750A)	361
Wheel Balance (ZX750A)	348	Swing Arm (ZX750A)	361
Disassembly		Uni-Trak Links (ZX750A)	361
Torque and Locking Agent (ZX750A)	350	Junction Box (ZX750A)	361
Air Suction Valves (US model)	351	Charging System (ZX750A)	371
Cylinder Head Studs	351	Ignition System (ZX750A)	371
Alternator Rotor	351	Electric Starter System (ZX750A)	371
Clutch (ZX750A)	351	Headlight System (ZX750A)	371
Clutch Release (ZX750A)	351	Tachometer (KZ/Z750L)	371
Oil Pressure Switch (KZ/Z750L)	351	Fuel Gauge (KZ/Z750L).	371
Transmission	351	LCD Fuel Gauge and Warner Unit (ZX750A)	371
Connecting Rods (ZX750A)	351	General Lubrication	381
Rear Wheel (ZX750A)	351	Bolts, Nuts, Fasteners	381
Disc Brakes (ZX750A)	353	Appendix	
Handlebar (KZ/Z750L)	353	Special Tool (ZX750A)	381
Handlebars (ZX750A)	354	Wiring Diagrams	381
Front Fork (KZ/Z750L).	354		

SAFETY AWARENESS

Whenever you see the symbols shown below, heed their instructions! Always follow safe operating and maintenance practices.

WARNING

○This warning symbol identifies special instructions or procedures which, if not correctly followed, could result in personal injury, or loss of life.

CAUTION

○This caution symbol identifies special instructions or procedures which, if not strictly observed, could result in damage to or destruction of equipment.

"NOTE"

○This note symbol indicates points of particular interest for more efficient and convenient operation.

LIST OF ABBREVIATIONS

A	ampere(s)	lb	pound(s)
ABDC	after bottom dead center	m	meter(s)
AC	alternating current	min	minute(s)
ATDC	after top dead center	N	newton(s)
BBDC	before bottom dead center	Pa	pascal(s)
BDC	bottom dead center	PS	horsepower
BTDC	before top dead center	psi	pound(s) per square inch
°C	degree(s) Celsius	r	revolution
DC	direct current	rpm	revolution(s) per minute
F	farad(s)	TDC	top dead center
°F	degree(s) Fahrenheit	TIR	total indicator reading
ft	foot, feet	V	volt(s)
g	gram(s)	W	watt(s)
h	hour(s)	Ω	ohm(s)

Unit Conversion Table

Prefixes for Units:

Prefix	Symbol	Power
mega	M	x 1,000,000
kilo	k	x 1,000
centi	c	x 0.01
milli	m	x 0.001
micro	μ	x 0.000001

Units of Volume:

L	x	0.2642	=	gal (US)
L	x	0.2200	=	gal (imp)
L	x	1.057	=	qt (US)
L	x	0.8799	=	qt (imp)
L	x	2.113	=	pint (US)
L	x	1.816	=	pint (imp)
mL	x	0.03381	=	oz (US)
mL	x	0.02816	=	oz (imp)
mL	x	0.06102	=	cu in

Units of Mass:

kg	x	2.205	=	lb
g	x	0.03527	=	oz

Units of Force:

N	x	0.1020	=	kg
N	x	0.2248	=	lb
kg	x	9.807	=	N
kg	x	2.205	=	lb

Units of Length:

km	x	0.6214	=	mile
m	x	3.281	=	ft
mm	x	0.03937	=	in

Units of Torque:

N-m	x	0.1020	=	kg-m
N-m	x	0.7376	=	ft-lb
N-m	x	8.851	=	in-lb
kg-m	x	9.807	=	N-m
kg-m	x	7.233	=	ft-lb
kg-m	x	86.80	=	in-lb

Units of Pressure:

kPa	x	0.01020	=	kg/cm ²
kPa	x	0.1450	=	psi
kPa	x	0.7501	=	cmHg
kg/cm ²	x	98.07	=	kPa
kg/cm ²	x	14.22	=	psi
cmHg	x	1.333	=	kPa

Units of Speed:

km/h	x	0.6214	=	mph
------	---	--------	---	-----

Units of Power:

kW	x	1.360	=	PS
kW	x	1.341	=	HP
PS	x	0.7355	=	kW
PS	x	0.9863	=	HP

Units of Temperature:

$$\frac{9}{5} (\text{°C} + 40) - 40 = \text{°F}$$

$$\frac{5}{9} (\text{°F} + 40) - 40 = \text{°C}$$

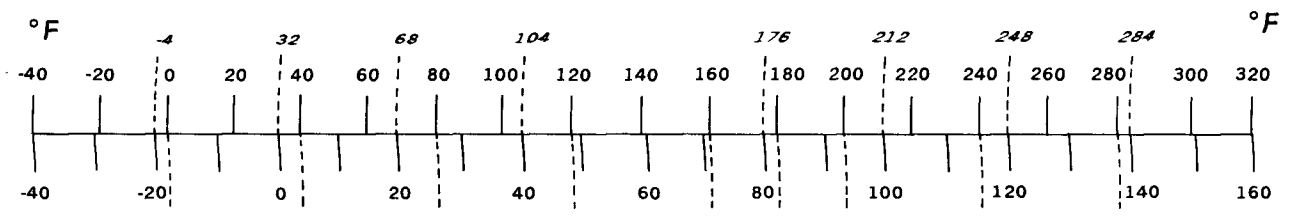

Model Identification

KZ750-H4

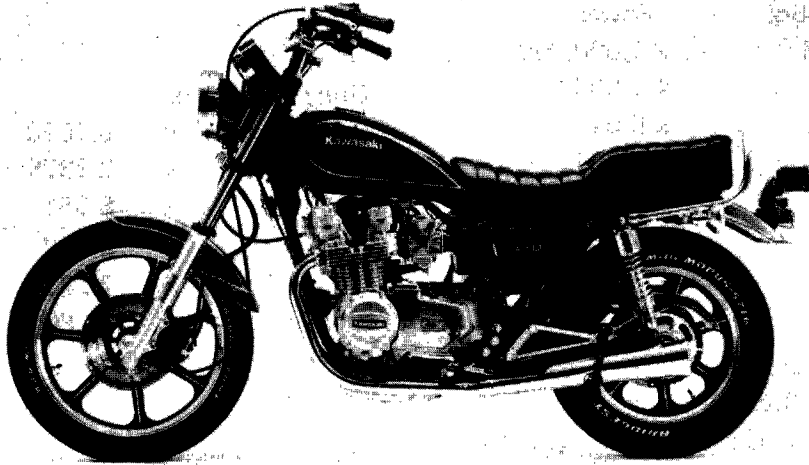

KZ750-L3

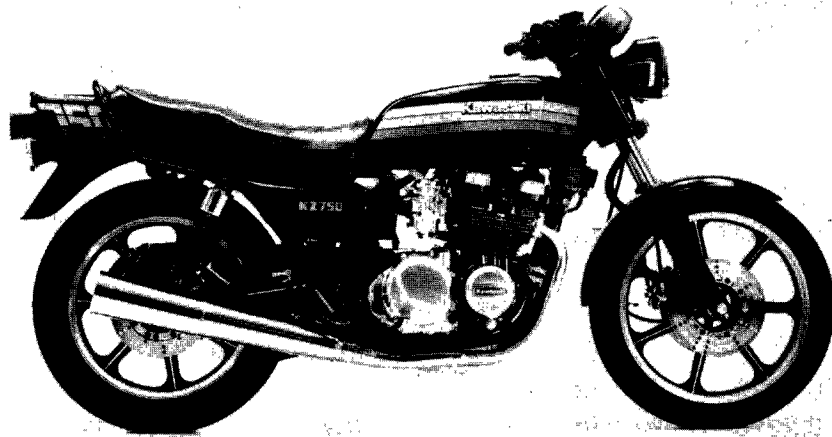

ZX750-A1

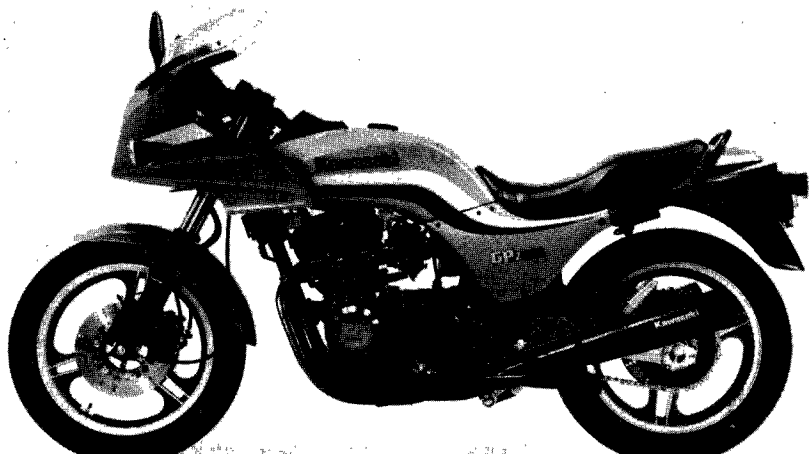

Specifications

.....
Specifications (KZ750H and KZ/Z750L)

Item	KZ750-H4	KZ/Z750-L3
Dimensions:		
Overall length	2,195 mm	2,215 mm © Ⓢ Ⓤ 2,170 mm
Overall width	840 mm	770 mm
Overall height	1,240 mm	1,135 mm © Ⓤ 1,130 mm
Wheelbase	1,450 mm	1,460 mm
Road clearance	155 mm	140 mm
Seat height	770 mm	800 mm
Dry weight	2,070 N (211.3 kg)	2,110 N (215 kg) © Ⓤ 2,120 N (216 kg)
Curb weight: Front	1,010 N (103 kg)	1,090 N (111 kg)
Rear	1,200 N (122 kg)	1,210 N (123 kg)
Fuel tank capacity	12.4 L	21.7 L
Performance:		
Climbing ability	30°	*
Braking distance	12.5 m from 50 km/h	*
Minimum turning radius	2.5 m	*
Engine:		
Type	4-stroke, DOHC, 4-cylinder	*
Cooling system	Air cooled	*
Bore and stroke	66.0 x 54.0 mm	*
Displacement	738 mL	*
Compression ratio	9.5	*
Maximum horsepower	55.2 kW (75 PS) @9,500 r/min (rpm)	58.8 kW (80 PS) @9,000 r/min (rpm)
Maximum torque	62.8 N-m (6.4 kg-m, 46.3 ft-lb) @7,500 r/min (rpm)	65.7 N-m (6.7 kg-m, 48.5 ft-lb) @7,500 r/min (rpm)
Carburetion system	Carburetors, Keihin CV34 x 4	Carburetors, Mikuni BS34 x 4
Starting system	Electric starter	*
Ignition system	Battery and coil (transistorized)	*
Timing advance	Mechanically advanced	*
Ignition timing	From 10° BTDC @1,050 r/min (rpm) to 40° BTDC @3,650 r/min (rpm)	*

340 SUPPLEMENT – 1983 MODEL

Item	KZ750-H4	KZ/Z750-L3
Spark plug	NGK B8ES or ND W24ES-U	NGK BR8ES or ND W24ESR-U Ⓐ Ⓘ Ⓢ Ⓤ NGK B8ES or ND W24ES-U
Cylinder numbering method	Left to right, 1-2-3-4	*
Firing order	1-2-4-3	*
Valve timing:		
Inlet		
Open	30° BTDC	*
Close	60° ABDC	*
Duration	270°	*
Exhaust		
Open	60° BBDC	*
Close	30° ATDC	*
Duration	270°	*
Lubrication system	Forced lubrication (wet sump)	Forced lubrication (wet sump with cooler)
Engine oil:		
Grade	SE class	*
Viscosity	SAE 10W40, 10W50, 20W40, or 20W50	*
Capacity	3.5 L	*
Drive Train:		
Primary reduction system:		
Type	Gear and chain	*
Reduction ratio	2.550 (27/23 x 63/29)	*
Clutch type	Wet multi disc	*
Transmission:		
Type	5-speed, constant mesh, return shift	*
Gear ratio:		
1st	2.333 (35/15)	*
2nd	1.631 (31/19)	*
3rd	1.272 (28/22)	*
4th	1.040 (26/25)	*
5th	0.875 (21/24)	*
Final drive system:		
Type	Chain drive	*
Reduction ratio	2.461 (32/13)	2.538 (33/13)
Overall drive ratio	5.492 @Top gear	5.664 @Top gear

SUPPLEMENT – 1983 MODEL 3

Items	KZ750-H4	KZ/Z750-L3
Frame:		
Type	Tubular, double cradle	*
Caster (rake angle)	30°	27°
Trail	121 mm	107 mm
Front tire:		
Type	Tubeless	*
Size	3.25H19 4PR	100/90-19 57H
Rear tire:		
Type	Tubeless	*
Size	130/90-16 67H	120/90-18 65H
Front suspension:		
Type	Telescopic fork (pneumatic)	*
Wheel travel	180 mm	150 mm
Rear suspension:		
Type	Swing arm	*
Wheel travel	95 mm	111 mm
Brake type:		
Front	Dual disc	*
Rear	Single disc	*
Electrical Equipment:		
Battery	12 V 12 AH	*
Headlight:		
Type	Semi-sealed beam	*
Bulb	12 V 60/55 W (quartz-halogen)	*
Tail/brake light	12 V 8/27 W x 2	12 V 5/21 W x 2 Ⓒ Ⓕ Ⓖ 12 V 8/27 W x 2
Alternator:		
Type	Three-phase AC	*
Rated output	17 A @10,000 r/min (rpm), 14 V	17 A @8,000 r/min (rpm), 14 V
Voltage regulator:		
Type	Short-circuit	*

Specifications subject to change without notice, and may not apply to every country.

Ⓐ : Australian Model
 Ⓒ : South African Model

Ⓒ : Canadian Model
 Ⓖ : U.S. Model

Ⓘ : Italian Model

342 SUPPLEMENT – 1983 MODEL

Specifications (ZX750A)

Items	ZX750-A1
Dimensions:	
Overall length	2,220 mm (C)(S)(U) 2,190 mm
Overall width	760 mm
Overall height	1,260 mm
Wheelbase	1,490 mm
Road clearance	150 mm
Seat height	800 mm
Dry weight	2,160 N (220 kg) (C)(U) 2,150 N (219 kg) (S) 2,170 N (221 kg)
Curb weight: Front	1,140 N (116 kg) (C)(U) 1,130 N (115 kg)
Rear	1,200 N (122 kg) (S) 1,210 N (123 kg)
Fuel tank capacity	19.0 L
Performance:	
Climbing ability	30°
Braking distance	12.5 m from 50 km/h
Minimum turning radius	2.7 m
Engine:	
Type	4-stroke, DOHC, 4-cylinder
Cooling system	Air cooled
Bore and stroke	66.0 x 54.0 mm
Displacement	738 mL
Compression ratio	9.5
Maximum horsepower	63.3 kW (86 PS) @9,500 r/min (rpm) (Sw)(W) 64.0 kW (87 PS) @9,500 r/min (rpm)
Maximum torque	67.7 N-m (6.9 kg-m, 50.0 ft-lb) @7,500 r/min (rpm) (Sw)(W) 68.6 N-m (7.0 kg-m, 51 ft-lb) @7,500 r/min (rpm)
Carburetion system	Carburetors, Mikuni BS34 x 4
Starting system	Electric starter
Ignition system	Battery and coil (transistorized)
Timing advance	Electronically advanced
Ignition timing	From 10° BTDC @1,050 r/min (rpm) to 40° BTDC @3,600 r/min (rpm)

Items	ZX750-A1
Spark plug	NGK BR9ES or ND W27ESR-U
	Ⓐ Ⓘ Ⓝ Ⓢ Ⓤ NGK B9ES or ND W27ES-U
Cylinder numbering method	Left to right, 1-2-3-4
Firing order	1-2-4-3
Valve timing:	
Inlet	Open 38° BTDC
	Close 68° ABDC
	Duration 286°
Exhaust	Open 68° BBDC
	Close 38° ATDC
	Duration 286°
Lubrication system	Forced lubrication (wet sump with cooler)
Engine oil:	
Grade	SE class
Viscosity	SAE 10W40, 10W50, 20W40, or 20W50
Capacity	3.5 L
Drive Train:	
Primary reduction system:	
Type	Gear and chain
Reduction ratio	2.550 (27/23 x 63/29)
Clutch type	Wet multi disc
Transmission:	
Type	5-speed, constant mesh, return shift
Gear ratios: 1st	2.333 (35/15)
2nd	1.631 (31/19)
3rd	1.272 (28/22)
4th	1.040 (26/25)
5th	0.875 (21/24)
Final drive system:	
Type	Chain drive
Reduction ratio	2.533 (38/15)
Overall drive ratio	5.652 @Top gear
Frame:	
Type	Tubular, double cradle
Caster (rake angle)	26.5°
Trail	103 mm

344 SUPPLEMENT – 1983 MODEL

Items	ZX750-A1
Front tire:	
Type	Tubeless
Size	110/90V18 © ① 110/90-18 61H
Rear tire:	
Type	Tubeless
Size	130/80V18 © ① 130/80-18 66H
Front suspension:	
Type	Telescopic fork (pneumatic)
Wheel travel	150 mm
Rear suspension:	
Type	Swing arm (uni-trak)
Wheel travel	130 mm
Brake type:	
Front	Dual disc
Rear	Single disc
Electrical Equipment:	
Battery	12 V 14 AH
Headlight:	
Type	Semi-sealed beam
Bulb	12 V 60/55 W (quartz-halogen)
Tail/brake light	12 V 5/21 W x 2 © ① ② 12 V 8/27 W x 2
Alternator:	
Type	Three-phase AC
Rated output	17 A @8,000 r/min (rpm), 14 V
Voltage regulator:	
Type	Short-circuit

Specifications subject to change without notice, and may not apply to every country.

Ⓐ : Australian Model
 Ⓝ : Norwegian Model
 Ⓤ : U.S. Model

© : Canadian Model
 Ⓢ : South African Model
 Ⓦ : West German Model

① : Italian Model
 Ⓢw : Swedish Model

.....
Periodic Maintenance Chart

The scheduled maintenance must be done in accordance with this chart to keep the motorcycle in good running condition. **The initial maintenance is vitally important and must not be neglected.**

OPERATION	FREQUENCY	*ODOMETER READING							See Page	
		Whichever comes first ↓ Every	800 km	5,000 km	10,000 km	15,000 km	20,000 km	25,000 km		30,000 km
Spark plug – clean		•	•	•	•	•	•	•	•	12
Spark plug – check †		•	•	•	•	•	•	•	•	12
Timing advancer – lubricate (Not on ZX750A)				•		•			•	227
Valve clearance – check †		•	•	•	•	•	•	•	•	12
Air suction valve – check † (US model)			•	•	•	•	•	•	•	166
Air cleaner element – clean			•	•		•				312,366
Air cleaner element – replace	5 cleanings			•		•			•	148,312
Throttle grip play – check †		•	•	•	•	•	•	•	•	291
Idle speed – check †		•	•	•	•	•	•	•	•	15
Engine vacuum synchronization – check †		•	•	•	•	•	•	•	•	15
Fuel system – check †				•		•			•	19, 291
Cylinder head bolt tightness – check †		•		•		•			•	35
Cylinder head nut tightness – check †		•		•		•			•	35
Engine oil – change	year	•	•	•	•	•	•	•	•	18
Oil filter – replace		•		•		•			•	18
Fuel hose – replace	4 years									–
Clutch – adjust		•	•	•	•	•	•	•	•	17,291,346
Drive chain wear – check †			•	•	•	•	•	•	•	198
Drive chain – lubricate	300 km									198
Drive chain slack – check †	800 km									23,347
Brake lining wear – check †			•	•	•	•	•	•	•	203
Brake fluid level – check †	month	•	•	•	•	•	•	•	•	207
Brake fluid – change	year			•		•			•	206
Brake hose – replace (Not on ZX750A)	4 years									208
Brake hose and pipe – replace (ZX750A)	4 years									208,367
Anti-dive brake plunger assembly – replace (ZX750A)	2 years									367
Master cylinder cup and dust seal – replace	2 years									201
Caliper piston seal and dust seal – replace	2 years									204
Brake light switch – check †		•	•	•	•	•	•	•	•	25
Steering – check †		•	•	•	•	•	•	•	•	26,293
Steering stem bearing – lubricate	2 years					•				209,318
Front fork oil – change				•		•			•	214,318,364
Tire wear – check †			•	•	•	•	•	•	•	193
Wheel bearing – lubricate	2 years					•				197
Speedometer gear – lubricate	2 years					•				197
Swing arm pivot – lubricate (Not on ZX750A)				•		•			•	276
Swing arm pivot, uni-trak linkage – lubricate (ZX750A)				•		•			•	368
Battery electrolyte level – check † (Not on ZX750A)	month	•	•	•	•	•	•	•	•	218
General lubrication – perform			•	•	•	•	•	•	•	381
Nut, bolt, and fastener tightness – check †		•		•		•			•	382

* : For higher odometer readings, repeat at the frequency interval established here.

Adjustment

.....
Clutch (ZX750A)

WARNING

○To avoid a serious burn, never touch the engine or exhaust pipes during clutch adjustment.

Adjustment

- Slide the dust cover at the clutch cable adjuster.
- Loosen the locknut and mounting nuts.
- Turn one cable adjuster and slide the other until the correct clutch lever play is obtained. Tighten the locknut and mounting nuts.

Clutch Lever Play

Standard:	2 – 3 mm
-----------	----------

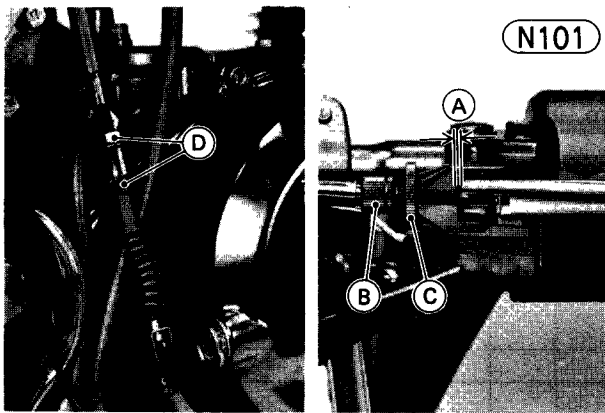

A. Clutch lever play
 B. Adjuster
 C. Locknut
 D. Mounting nuts

WARNING

○Be sure the upper end of the clutch outer cable is fully seated in its fitting, or it could slip into place later, creating enough cable play to prevent clutch disengagement, resulting in hazardous riding condition.

- Slide back the cable adjuster dust cover.
- After the adjustment is made, start the engine and check that the clutch does not slip and that it releases smoothly.

.....
Front Fork (ZX750A)

Anti-dive mechanism is attached to the lower end of each fork leg. Adjust it as following.

Anti-Dive Adjustment

The anti-dive adjuster on each front fork leg has 3 positions so that the anti-dive system can be adjusted for different road and loading conditions. The numbers on the adjuster show the setting position of the anti-dive system.

- Turn the anti-dive adjuster until you feel a click so that the desired position number comes to the front.
- Check to see that both adjusters are turned to the same relative position.

WARNING

○If both anti-dive adjusters are not adjusted equally, handling may be impaired and a hazardous condition may result.

Anti-Dive Adjustment

Position	1	2	3
Anti-dive	Weak	Moderate	Strong

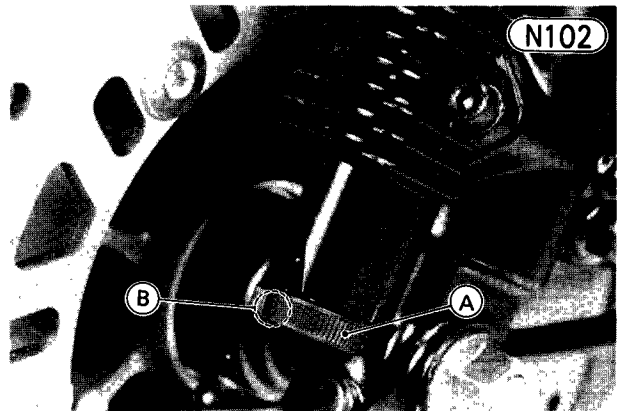

A. Anti-dive adjuster
 B. Position number

.....
Rear Shock Absorber (ZX750A)

This shock unit is an air assisted and damping

Inspection of Air Pressure

- Put the motorcycle up on its center stand to raise the rear wheel off the ground.
- Use air pressure gauge 52005-1003 specially made for air suspensions.
- Check and adjust the air pressure when the rear shock absorber is cold (room temperature).

“NOTE”

- Do not use a tire gauge for checking air pressure. They may not indicate the correct air pressure because of air leaks that occur when the gauge is applied to the valve.
- Lower air pressure is for comfortable riding for an average-built rider of 670N (68 kg) with no accessories. Ordinarily, the heavier the total load becomes, the higher the air pressure should be set.

CAUTION

- Inject air little by little so that air pressure does not rise rapidly. Air pressure exceeding 490 kPa (5.0 kg/cm², 71 psi) may damage the oil seal.

WARNING

- Be sure to adjust the air pressure within the usable range. Pressure too high or too low can produce a hazardous riding condition.
- Only air or nitrogen gas can be used. Never inject oxygen or any kind of explosive gas.
- Do not incinerate the rear shock absorber.

Rear Shock Absorber Air Pressure

Air Pressure kPa (kg/cm ² , psi)	Setting	Load	Road
49 (0.5, 7.1)	Soft	Light	Good
↑ ↓	↑ ↓	↑ ↓	↑ ↓
294 (3.0, 43)	Hard	Heavy	Bad

“NOTE”

- The recommended air pressure is 49 kPa (0.5 kg/cm², 7.1 psi) for one rider with no accessories.

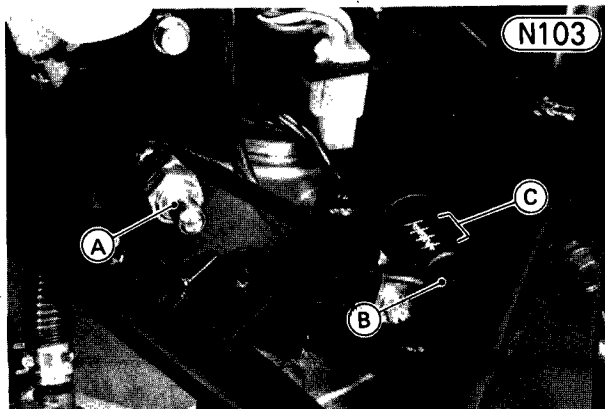

A. Air valve

C. Position number

Adjustment of Damping Force

- Pull or push the adjusting stick to the desired setting position until you feel a click. The numbers on the adjusting stick show the setting position of the damper. Position 1 – the fully-pushed-in position. Position 2 – the first click position on the adjusting stick return way. Position 3 – the second click position on the adjusting stick return way. Position 4 – the fully-pulled-out position.

“NOTE”

- The damping force can be left soft for average riding. But it should be adjusted harder for high speed riding, or riding with a passenger. If the damper setting feels too soft or too stiff, adjust it in accordance with the following table:

Damping Force

Setting Position	Damping Force	Setting	Load	Road	Speed
1	Stronger ↓ ↓ ↓	Soft	Light	Good	Low
2		↑	↑	↑	↑
3		↓	↓	↓	↓
4		Hard	Heavy	Bad	High

“NOTE”

- The recommended setting position is 1 (2 for US, Canada) for one rider with no accessories.

Drive Chain (ZX750A)

The drive chain must be checked, adjusted, and lubricated in accordance with the Periodic Maintenance Chart for safety and to prevent excessive wear. If the chain becomes badly worn or maladjusted-either too loose or too tight-the chain could jump off the sprockets or break.

WARNING

- A chain that breaks or jumps off the sprockets could snag on the engine sprocket or lock the rear wheel, severely damaging the motorcycle and causing it to go out of control.

Chain Slack Inspection

- Set the motorcycle up in its center stand.
- Check to see if wheel alignment is properly adjusted. The left and right notches on the swing arm should point to the same marks or positions on the left and right chain adjuster. If they do not, adjust wheel alignment as described in the later paragraph – Whee

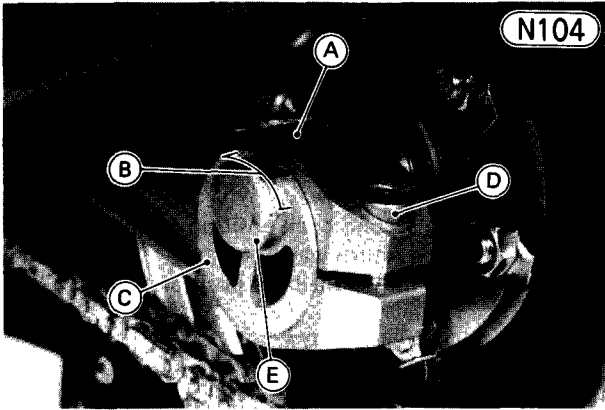

- A. Swing arm notch
- B. Marks
- C. Chain adjuster
- D. Clamp bolt
- E. Rear axle

"NOTE"

○Wheel alignment can also be checked using the straightedge or string method.

WARNING

○Misalignment of the wheel will result in abnormal wear, and may result in an unsafe riding condition.

- Rotate the rear wheel to find the position where the chain is tightest, and measure the vertical movement midway between the sprockets.
- If the drive chain is too tight or too loose adjust it so that the chain slack will be within the standard value.

Chain Slack Inspection

282111

N105

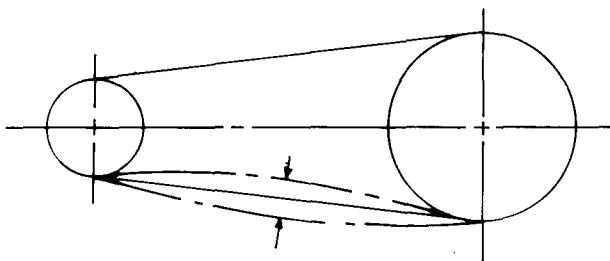

Drive Chain Slack

Standard:	35 – 40 mm
Too Tight:	Less than 35 mm
Too Loose:	More than 45 mm

Chain Slack Inspection

- Loosen the left and right chain adjuster clamp bolts.
- Insert a screw driver bit into the rear axle head hole, and turn the chain adjusters forward or rearward until the driver chain has the correct amount of chain slack.
- Tighten the chain adjuster clamp bolts to the specified

WARNING

○If the clamp bolts are not securely tightened, an unsafe riding condition may result.

- Rotate the wheel, measure the chain slack again at the tightest position, and readjust if necessary.
- Check the rear brake effectiveness.

Wheel Alignment Adjustment

- Remove the cotter pin from the axle nut, and loosen the axle nut.
- Loosen the left or right chain adjuster clamp bolt, and turn the chain adjuster so that the left and right notches on the swing arm should point to the same marks or positions on the left and right adjusters.
- Tighten the clamp bolt and axle nut to the specified torque.
- Insert a new cotter pin through the axle nut, and spread its ends.

WARNING

○If the axle nut and clamp bolts are not securely tightened and the cotter pin is not installed, an unsafe riding condition may result.

Tightening Torque

Adjuster Clamp Bolts:	32 N-m (3.3 kg-m, 24 ft-lb)
Axle Nut:	120 N-m (12.0 kg-m, 87 ft-lb)

Wheel Balance (ZX750A)

Refer to p. 27 – 28, noting the following.

- The new-style balance weight can be removed and installed as following.

Installation of Balance Weight

- Check that the weight portion has any play on the blade-and-clip plate.
- ★If it does, discard it.
- Lubricate the balance weight blade, tire bead, and rim flange with a soap and water solution or rubber lubricant. This helps the balance weight slip on the rim flange.

CAUTION

○Do not lubricate the tire bead with engine oil or

- Install the balance weight on the rim.
- Slip the weight on the rim flange by pushing or lightly hammering the weight in the direction shown in the figure.
- Check that the blade and weight seat fully on the rim flange, and that the clip is hooked over the rim ridge and reaches rim flat portion.

WARNING

- If the balance weight has any play on the rim flange, the blade and/or clip of the weight are widened. Replace the loose balance weight.
- Do not reuse used balance weights.

Balance Weight

Part Number	Weight (grams)
41075-1014	10
41075-1015	20
41075-1016	30

Removal of Balance Weight

- (a) When the tire is not on the rim.
- Push the blade portion toward the outside with a regular tip screw driver, and slip the weight off the rim flange.
 - Discard the used balance weight.
- (b) When the tire is on the rim.
- Pry the Balance weight off the rim flange using a regular tip screw driver as shown in the figure.
 - Insert a tip of the screw driver between the tire bead and the weight blade until the end of the tip reaches the end of the weight blade.
 - Push the driver grip toward the tire so that the balance weight slips off the rim flange.
 - Discard the used balance weight.

Installing Balance Weight

482530

- (a) Press or lightly hammer the weight in.

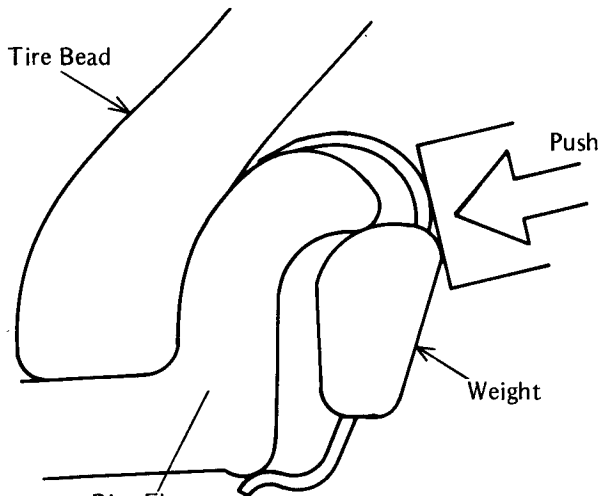

Removing Balance weight (without tire on rim)

482531

N106

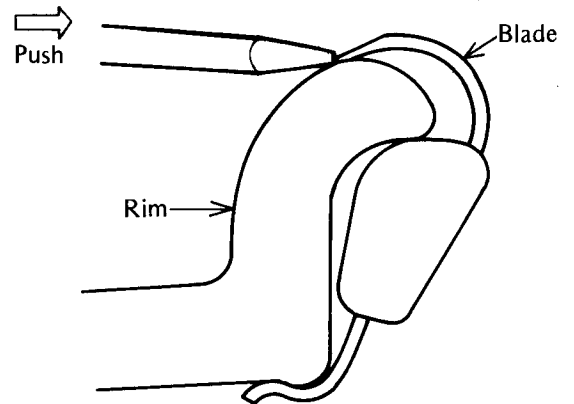

Removing Balance Weight (with tire on rim)

482532

N107

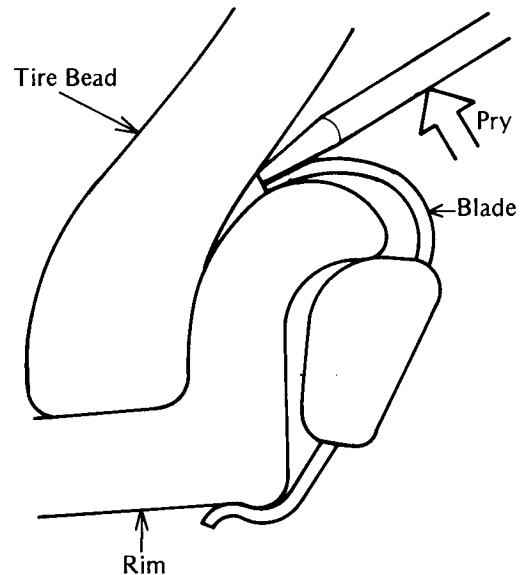

- (b) Installation completed.

N108

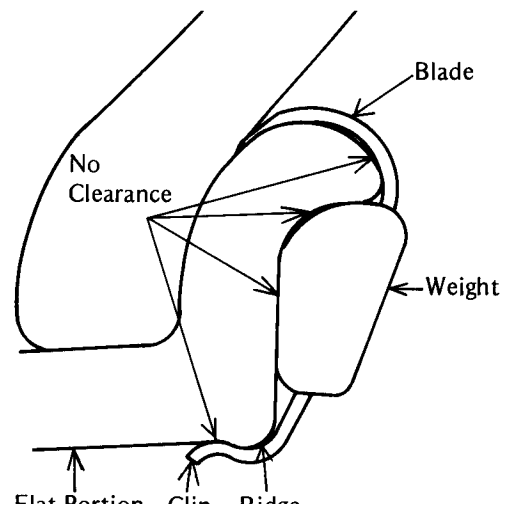

Disassembly

Torque and Locking Agent (ZX750A)

The table below shows the tightening torque for the ZX750A. Unless otherwise noted, refer to p. 35 – 38, p. 273, and p. 294.

Parts	Threads		Quantity	Torque			Remarks	See Page
	Dia. (mm)	Pitch (mm)		N-m	kg-m	ft-lb		
Engine								
Alternator rotor bolt	12	1.25	1	125	13.0	94	—	351
Engine sprocket nut	20	1.5	1	98	10.0	72	—	66
Wheels:								
Chain adjuster clamp bolts	10	1.5	2	32	3.3	24	—	357
Brakes:								
Metal pipe nipples	10	1.25	4	23	2.3	16.5	—	355
Caliper mounting bolts (front and rear calipers)	10	1.25	6	32	3.3	24	—	353
Steering:								
Handlebar clamp bolts	6	1.0	4	9.8	1.0	87 in-lb	—	354
Handlebar holder bolts	32	1.5	2	74	7.5	54	—	354
Handlebar weight screws	8	1.25	2	—	—	—	•	
Steering stem head bolt	14	1.5	1	42	4.3	31	—	293
Suspensions:								
Anti-dive valve assembly mounting bolts	6	1.0	4	6.9	0.70	61 in-lb	—	355
Anti-dive brake plunger assembly mounting bolts	6	1.0	4	4.4	0.45	39 in-lb	—	355
Rear shock absorber air hose male pipe	8	1.0	1	12	1.2	104 in-lb	•	356
Rear shock absorber air valve	8	1.0	1	7.8	0.80	69 in-lb	•	356
Rear shock absorber nuts: upper	10	1.25	1	37	3.8	27	—	356
lower	12	1.25	1	69	7.0	51	—	356
Uni-trak links:								
Rocker arm pivot shaft nut	12	1.25	1	69	7.0	51	—	356
Tie-rod nuts: upper	10	1.25	2	37	3.8	27	—	356
lower	12	1.25	1	69	7.0	51	—	356

.....
Air Suction Valves (US model)

The air suction valve assemblies are modified and the gaskets under the valve assemblies are deleted.

.....
Cylinder Head Studs

The 8 mm dia. studs will be used for the cylinder head studs. The upper studs differ from the lower studs. The upper ones are shorter than the lower ones.

.....
Alternator Rotor

The 12 mm dia. bolt will be used for the alternator rotor bolt.

Tightening Torque

Rotor bolt:	
12 mm dia.	125 N-m (13.0 kg-m, 94 ft-lb)
10 mm dia.	69 N-m (7.0 kg-m, 51 ft-lb)

.....
Clutch (ZX750A)
Clutch Release (ZX750A)

Refer to p. 74 – 76, noting the following.
 ●When installing the clutch cover, check and see that the clutch release lever comes to the proper angle with the level.

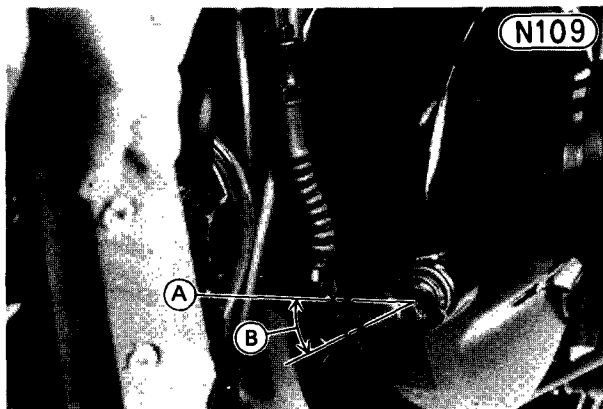

.....
Oil Pressure Switch (KZ/Z750L)

Refer to the informations for the oil pressure switch on p. 74.

.....
Transmission

Refer to p. 98 – 103, p. 297, noting the following.

Output Shaft:

The O-ring (39 in Fig. F63 on p. 100) will be deleted from the drive shaft assembly. When the O-ring is deleted, the collar (38 in Fig. F63) is modified so that the collar is press-fitted to the output shaft.

.....
Connecting Rods (ZX750A)

The connecting rods for the ZX750A have not the oil holes. So, it is not necessary to align the oil hole on the connecting rod with the oil hole on the bearing insert.

.....
Rear Wheel (ZX750A)

Removal and Installation:

●Check to see that there is no gap between the swing arm and each chain adjuster flange.

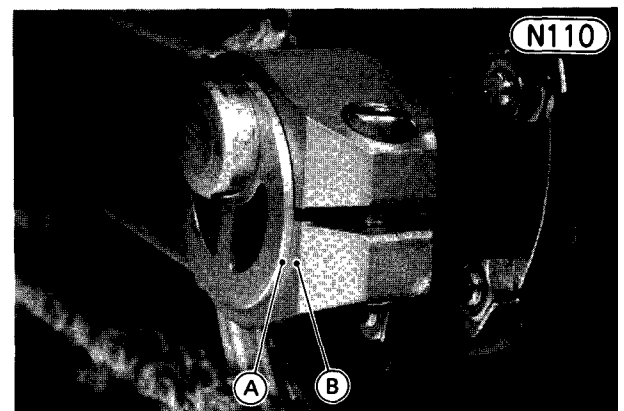

A. Chain adjuster flange B. Swing arm

352 SUPPLEMENT – 1983 MODEL

Clutch, Clutch Release (ZX750A)

682159

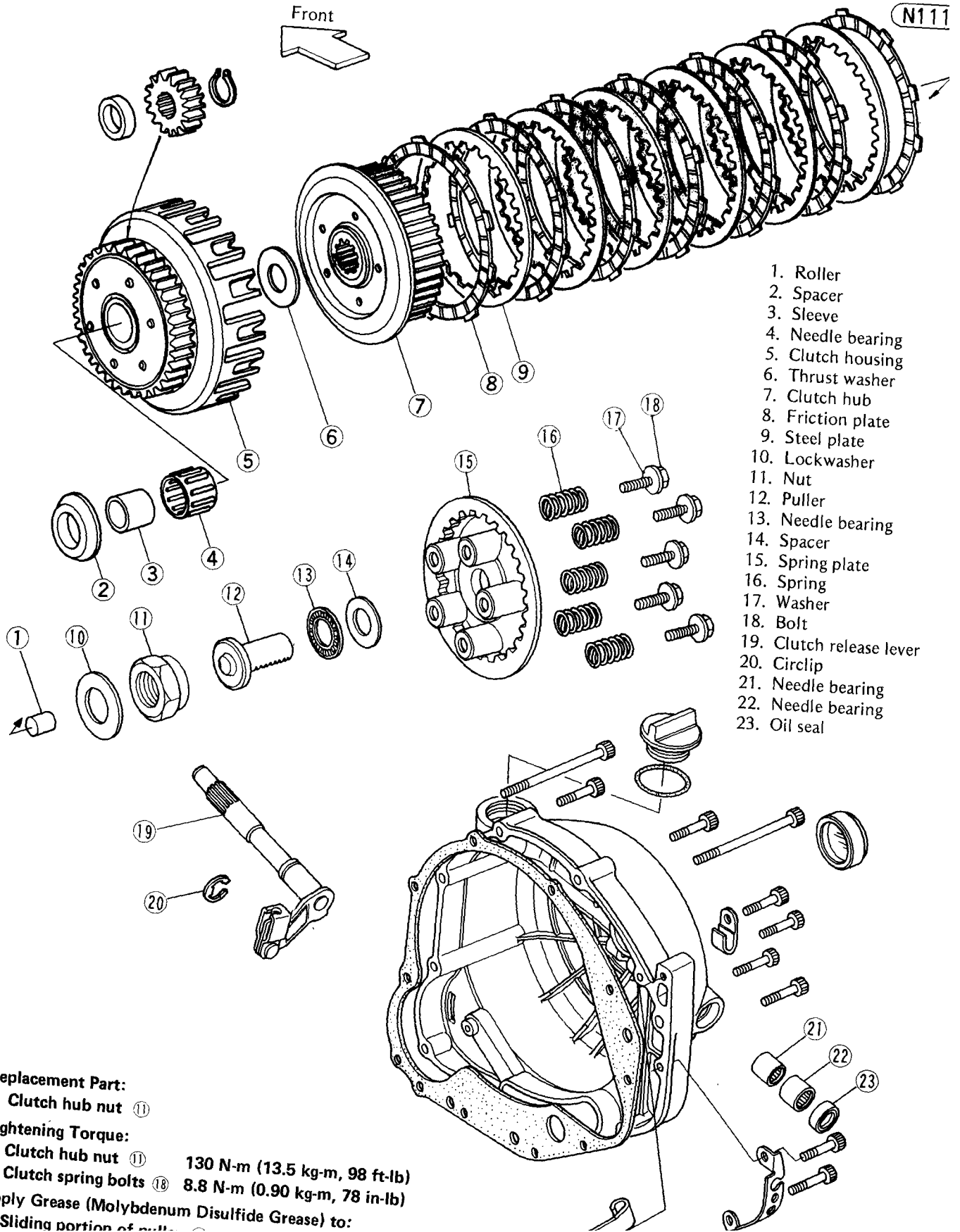

1. Roller
2. Spacer
3. Sleeve
4. Needle bearing
5. Clutch housing
6. Thrust washer
7. Clutch hub
8. Friction plate
9. Steel plate
10. Lockwasher
11. Nut
12. Puller
13. Needle bearing
14. Spacer
15. Spring plate
16. Spring
17. Washer
18. Bolt
19. Clutch release lever
20. Circlip
21. Needle bearing
22. Needle bearing
23. Oil seal

Replacement Part:
 Clutch hub nut ⑪

Tightening Torque:
 Clutch hub nut ⑪ 130 N-m (13.5 kg-m, 98 ft-lb)
 Clutch spring bolts ⑱ 8.8 N-m (0.90 kg-m, 78 in-lb)

Apply Grease (Molybdenum Disulfide Grease) to:
 Sliding portion of roller

Disc Brakes (ZX750A)

Refer to p. 118 — 127, noting the following.
 ●Clamp the rear brake hose in the hose clamps on the swing arm. Be sure that the hose clamps should be installed to the proper position shown in the figure.

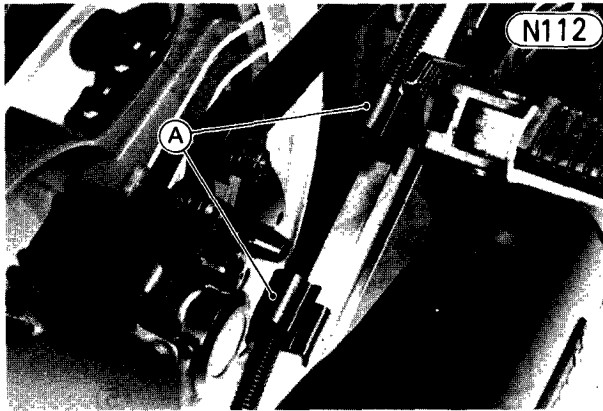

A. Hose clamps

Handlebar (KZ/Z750L)

Refer to p. 136 — 138, noting the following.

Handlebar
782130

N113

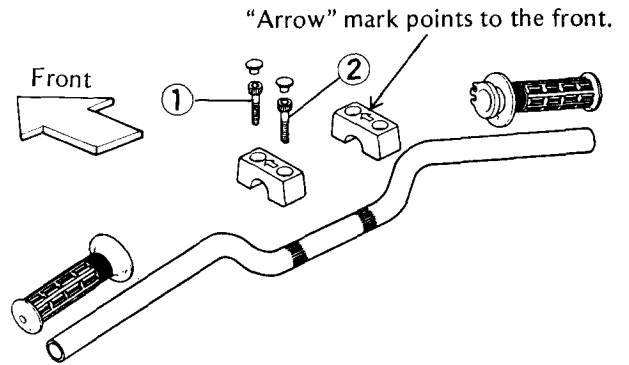

Tightening Sequence and Torque:

- 1. Front bolts ① 19 N-m (1.9 kg-m, 13.5 ft-lb)
- 2. Rear bolts ② 19 N-m (1.9 kg-m, 13.5 ft-lb)

Calipers (ZX750A)

782131

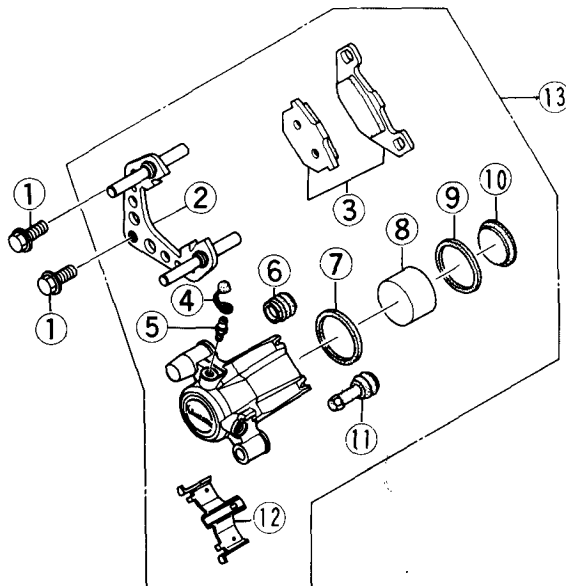

- Apply PBC* Grease to: Shafts on holders ②, ⑮
Collars ⑰, ⑱
- Tightening Torque:
 Bleed valves ⑤ 7.8 N-m (0.80 kg-m, 69 in-lb)
 Caliper mounting bolts ①, ⑲ 32 N-m (3.3 kg-m, 24 ft-lb)

* : PBC grease is a special high temperature, water-

N114

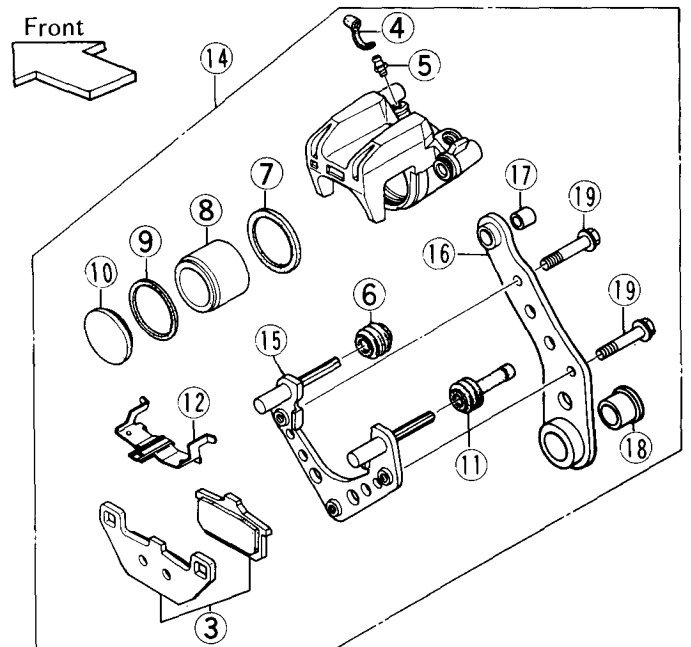

- 1. Mounting bolts
- 2. Caliper holder
- 3. Pads
- 4. Rubber cap
- 5. Bleed valve
- 6. Boot
- 7. Fluid seal
- 8. Piston
- 9. Dust seal
- 11. Friction boot
- 12. Anti-rattle spring
- 13. Front caliper
- 14. Rear caliper
- 15. Caliper holder
- 16. Holder
- 17. Collar
- 18. Collar
- 19. Mounting bolts

354 SUPPLEMENT – 1983 MODEL

Handlebars (ZX750A)

Refer to p. 306 – 307, noting the following.

- The handlebar holder positioning plate must be installed so that the triangular marks on the plate points to the front.
- Install the handlebars to the handlebar holders so that the mark on the handlebar aligns with the slit on the holder.

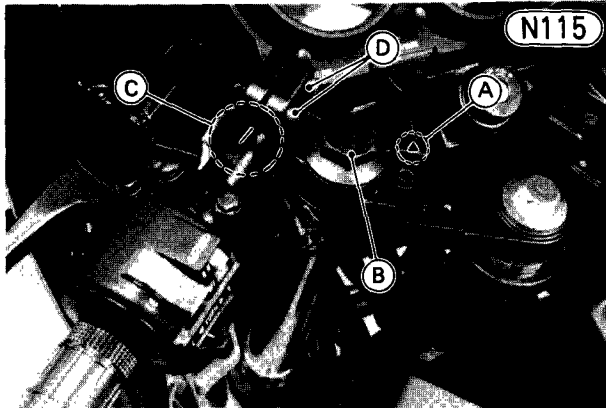

A. Triangular mark C. Align the mark with the slit
B. Holder bolt D. Handlebar clamp bolts

Tightening Torque

Holder bolts:	74 N-m (7.5 kg-m, 54 ft-lb)
Handlebar clamp bolts:	9.8 N-m (1.0 kg-m, 87 in-lb)

Front Fork

782132

N116

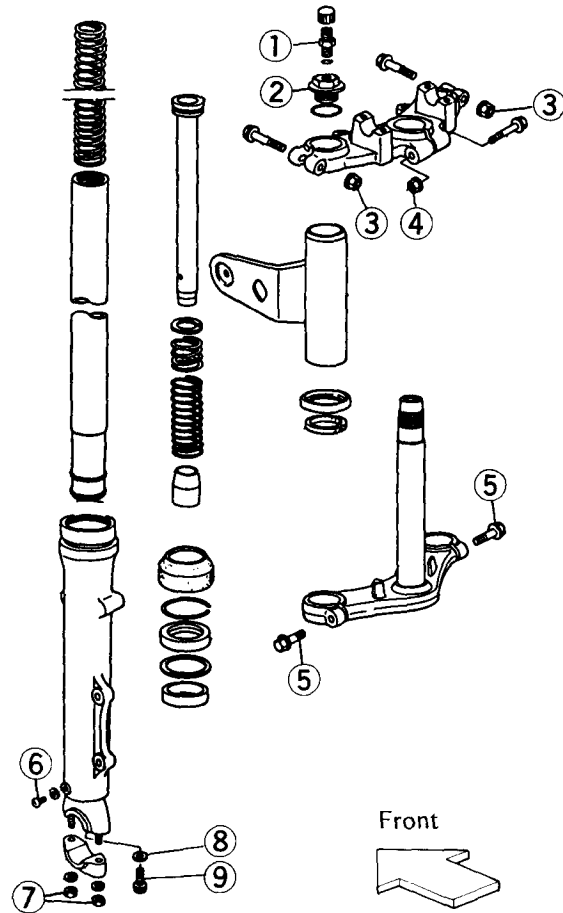

Front Fork (KZ/Z750L)

Refer to p. 140 – 143, noting the following.

Tightening Torque:

Air valves ①	7.8 N-m (0.80 kg-m, 69 in-lb)
Top plugs ②	23 N-m (2.3 kg-m, 16.5 ft-lb)
Nuts, upper clamp bolt ③	21 N-m (2.1 kg-m, 15.0 ft-lb)
Nut, stem head clamp bolt ④	21 N-m (2.1 kg-m, 15.0 ft-lb)
Bolts, lower clamp ⑤	37 N-m (3.8 kg-m, 27 ft-lb)
Nuts, stem clamp ⑥	14 N-m (1.4 kg-m, 10.0 ft-lb)

Apply Locking Agent to:

Apply Liquid Gasket to:

①, ②, ③, ④, ⑤, ⑥, ⑦, ⑧, ⑨

①, ②, ③, ④, ⑤, ⑥, ⑦, ⑧, ⑨

Front Fork (ZX750A)

Refer to p. 307 – 309, noting the following.

- Anti-dive unit is attached to the lower end of each fork leg, and contains the brake plunger assembly and the anti-dive valve assembly.

Front Fork
782133

1. Anti-dive brake plunger assembly
2. Bleed valve
3. Mounting bolt
4. Mounting bolt
5. Anti-dive valve assembly
6. O-ring
7. Drain screw
8. Gasket
9. Gasket
10. Bottom bolt
11. Main spring
12. Inner tube
13. Dust seal
14. Retainer
15. Washer
16. Oil seal
17. Washer
18. Guide bush
19. Outer tube

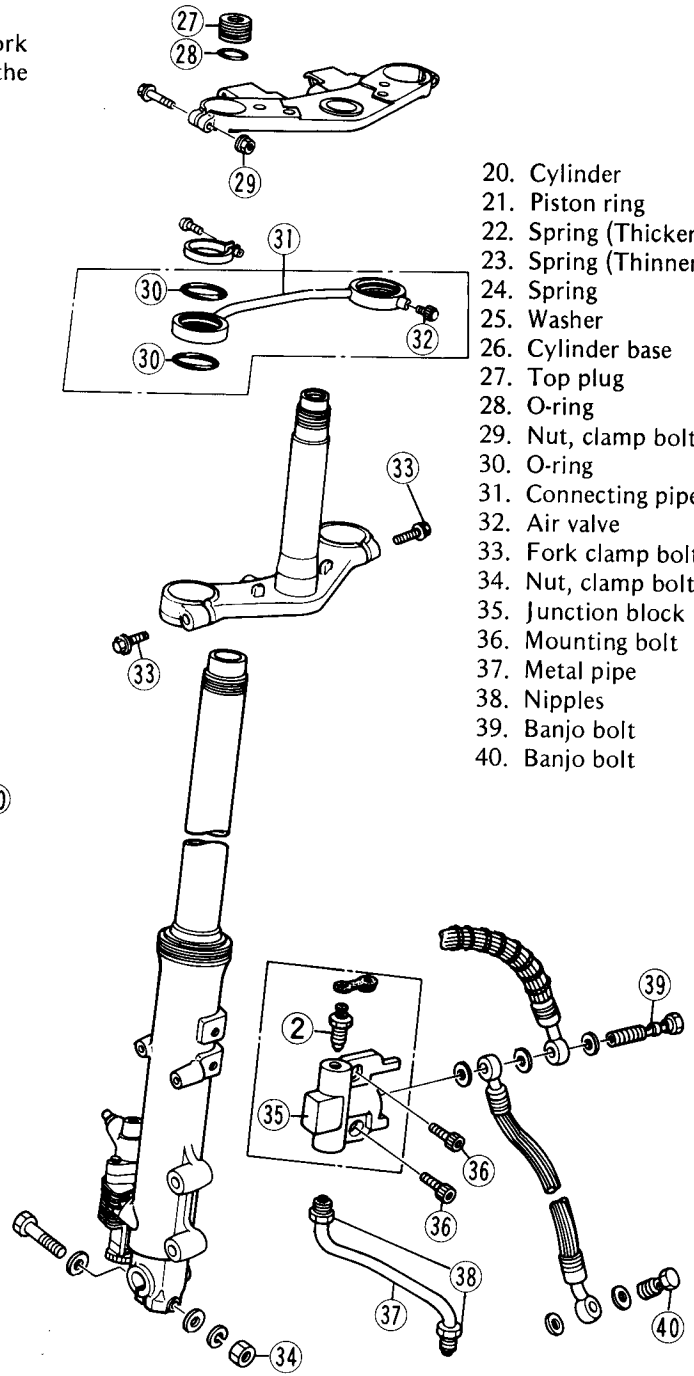
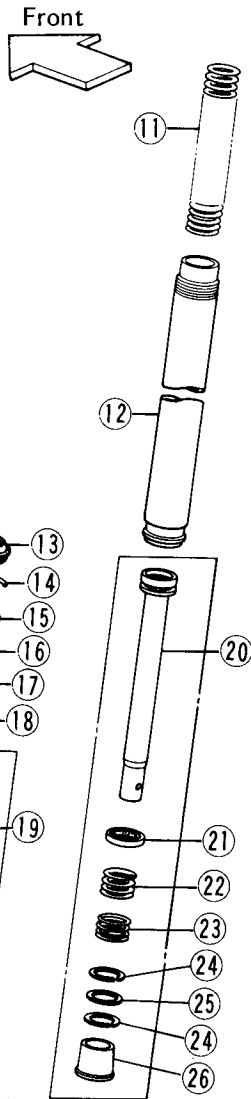
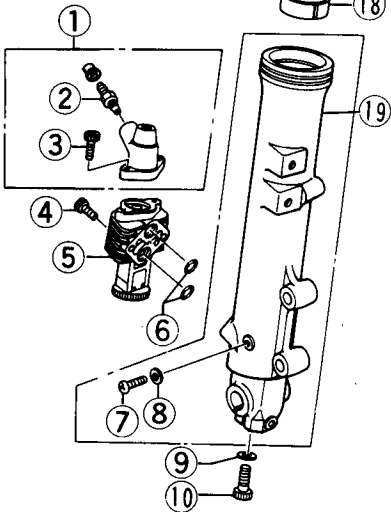

20. Cylinder
21. Piston ring
22. Spring (Thicker)
23. Spring (Thinner)
24. Spring
25. Washer
26. Cylinder base
27. Top plug
28. O-ring
29. Nut, clamp bolt
30. O-ring
31. Connecting pipe
32. Air valve
33. Fork clamp bolt
34. Nut, clamp bolt
35. Junction block
36. Mounting bolt
37. Metal pipe
38. Nipples
39. Banjo bolt
40. Banjo bolt

Apply Liquid Gasket to: Drain screws ⑦
Gaskets ⑨

Apply Locking Agent to: Air valve ③②
Bottom bolts ⑩

Tightening Torque:
Air valve ③② 7.8 N-m (0.80 kg-m, 69 in-lb)
Anti-dive valve assembly mounting bolts ④ 6.9 N-m (0.70 kg-m, 61 in-lb)
Axle clamp bolt nut ③④ 20 N-m (2.0 kg-m, 14.5 ft-lb)

Bottom bolts ⑩ 23 N-m (2.3 kg-m, 16.5 ft-lb)
Brake hose banjo bolts ③⑨, ④⑩ 25 N-m (2.5 kg-m, 18.0 ft-lb)
Brake metal pipe nipples ③⑧ 15 N-m (1.5 kg-m, 11.0 ft-lb)
Fork clamp bolt nuts ②⑨ 20 N-m (2.0 kg-m, 14.5 ft-lb)
Fork clamp bolts ③③ 37 N-m (3.8 kg-m, 27 ft-lb)
Plunger assembly mounting bolts ③ 4.4 N-m (0.45 kg-m, 39 in-lb)

356 SUPPLEMENT – 1983 MODEL

Rear Shock Absorber (ZX750A)
Swing Arm (ZX750A)
Uni-Trak Links (ZX750A)

Rear Shock Absorber, Uni-Trak Links

782134

- | | |
|---------------------------------|------------------------|
| 1. Rear shock absorber assembly | 15. Needle bearing |
| 2. Air valve | 16. Nut, tie rod lower |
| 3. Air hose | 17. Tie rod |
| 4. Male pipe | 18. Spherical bearing |
| 5. O-ring | 19. Collar |
| 6. Nut, upper bolt | 20. Grease seal |
| 7. Nut, lower bolt | 21. Nut, tie rod upper |
| 8. Nut, pivot shaft | |
| 9. Sleeve | |
| 10. Grease seal | |
| 11. Needle bearing | |
| 12. Rocker arm | |
| 13. Sleeve | |
| 14. Sleeve | |

Removal and Installation Point

● Inspect the dust seals and bearings, and lubricate the bearings before installation. See p. 368 – 369.

N118

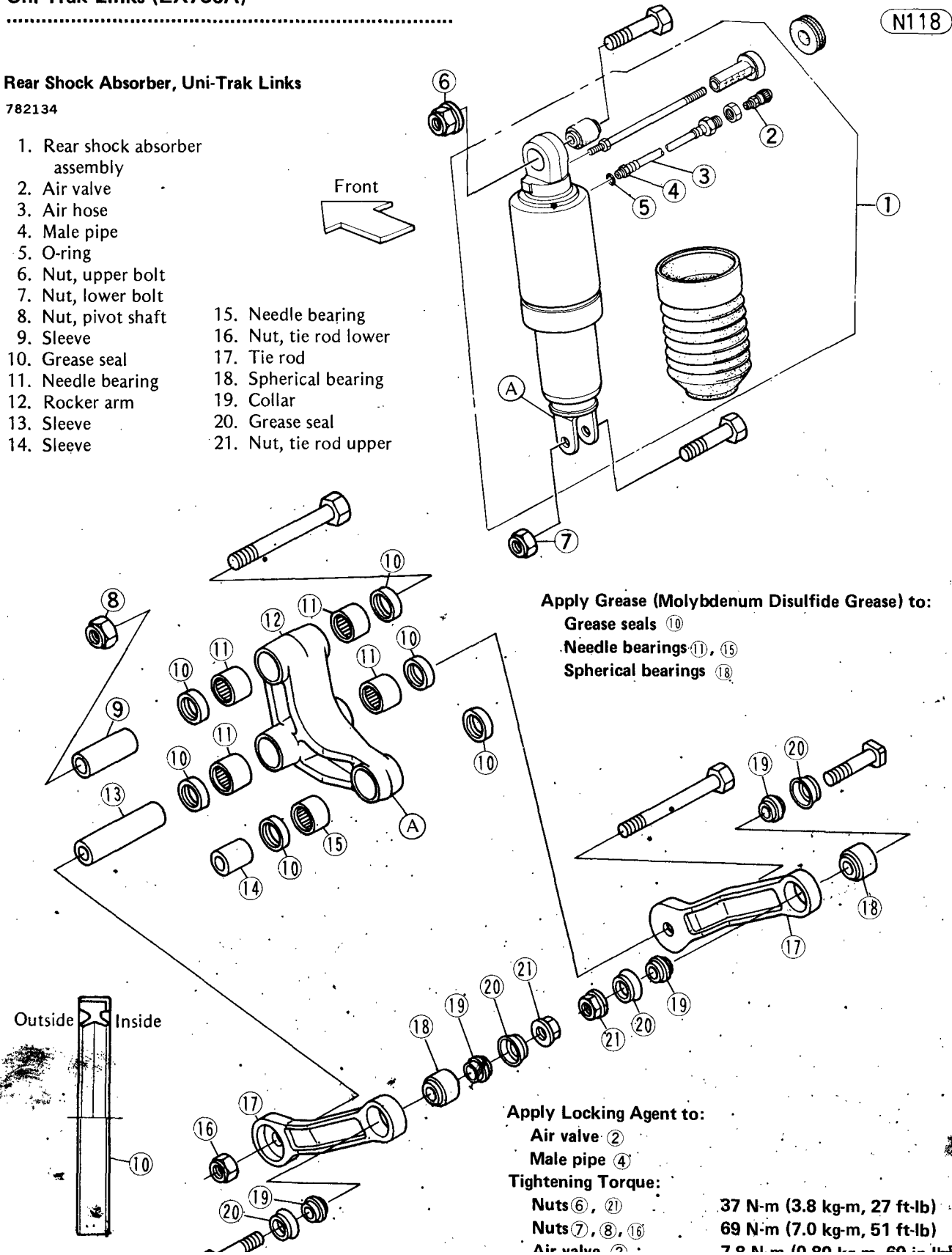

Apply Grease (Molybdenum Disulfide Grease) to:
Grease seals 10
Needle bearings 11, 15
Spherical bearings 18

Apply Locking Agent to:

- Air valve 2
- Male pipe 4

Tightening Torque:

- Nuts 6, 21
- Nuts 7, 8, 16
- Air valve 2

37 N-m (3.8 kg-m, 27 ft-lb)
69 N-m (7.0 kg-m, 51 ft-lb)

70 N-m (7.0 kg-m, 50 ft-lb)

Swing Arm
782135

N119

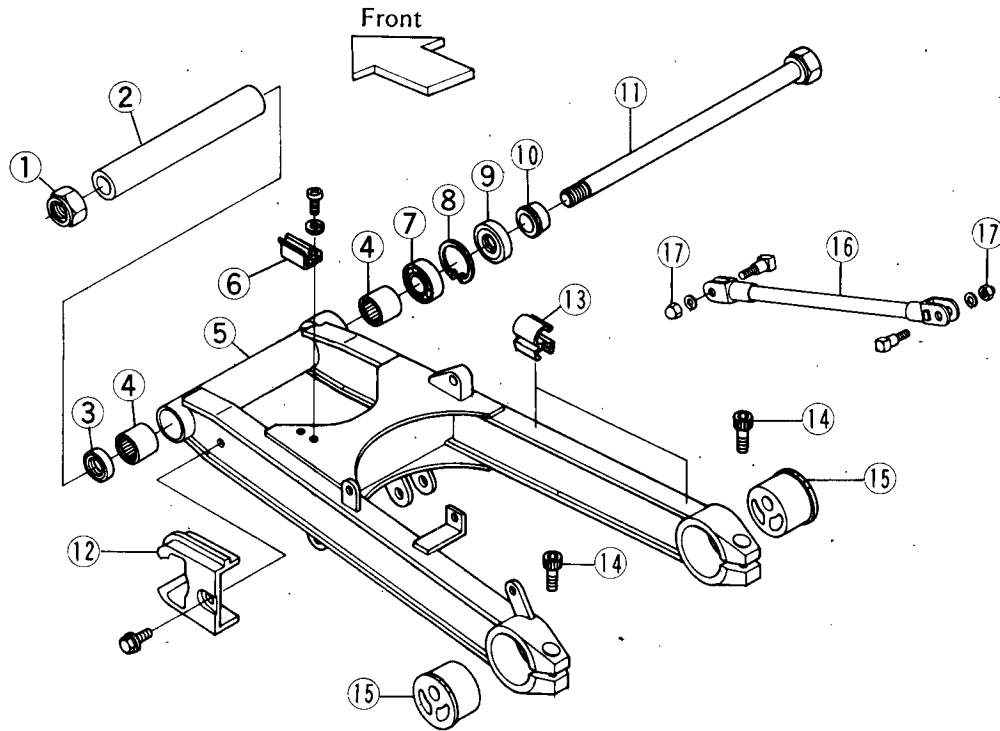

- | | |
|-----------------------|----------------------|
| 1. Pivot shaft nut | 10. Collar |
| 2. Sleeve | 11. Pivot shaft |
| 3. Grease seal | 12. Protector |
| 4. Needle bearing | 13. Brake hose clamp |
| 5. Swing arm | 14. Clamp bolt |
| 6. Chain cover holder | 15. Chain adjuster |
| 7. Ball bearing | 16. Torque link |
| 8. Circlip | 17. Torque link nut |
| 9. Grease seal | |

Apply Grease (Molybdenum Disulfide Grease) to:

- Grease seals ③, ⑨
- Needle bearings ④
- Ball bearing ⑦

Tightening Torque:

- Pivot shaft nut ① 98 N-m (10.0 kg-m, 72 ft-lb)
- Clamp bolts ⑭ 32 N-m (3.3 kg-m, 24 ft-lb)
- Torque link nuts ⑰ 29 N-m (3.0 kg-m, 22 ft-lb)

.....
Junction Box (ZX750A)
.....

Removal Point of Junction Box Parts

- Unlock the locking arm(s), and pull the relays and connectors straight off the junction box.

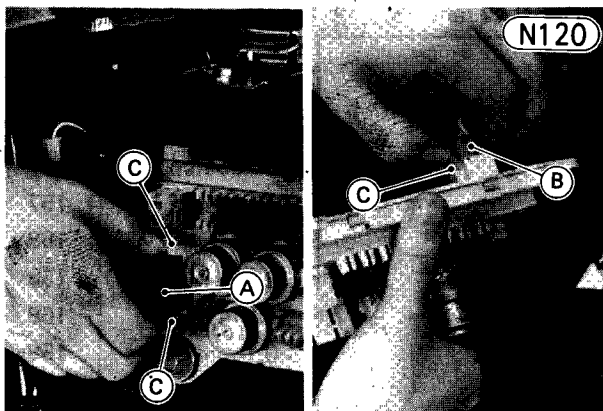

A. Turn signal relay

C. Unlock the locking arm(s)

Installation Point of Junction Box Parts

- Orient the relays and connectors correctly.
- Push the relays and connectors all the way in place until you feel a click.

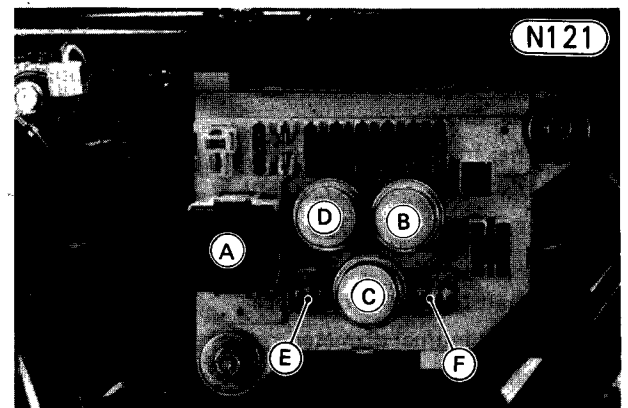

A. Turn signal relay
B. Main relay
C. Starter circuit relay

E. Diode assembly for headlight relay
F. Diode assembly for

Maintenance

Service Data

The following tables list the service data which show criteria for servicing 1983 models. Although reliable measurements can only be obtained by using the proper instruments and following the procedures explained in this manual, detail has not been explained in this section. See each section for a detailed account.

"NOTE"

- "Standards": Show dimensions or performances which brand-new parts or systems have.
- "Service Limits": Indicate the usable limits. If the measurement shows excessive wear or deteriorated performance, replace the damaged parts.

Engine:

Item	Standard			Service Limit	See Page
Throttle grip play	2 – 3 mm				291
Idle speed	1,050 ±50 r/min (rpm)				15
Engine vacuum synchronization	Less than 2.7 kPa (2 cmHg) difference between any two cylinders				15
Carburetors:	KZ750H	KZ/Z750L	ZX750A		
Make, Type	Keihin, CV34	Mikuni, BS34	Mikuni, BS34		
Main jet	#65 (Primary) #90 (Secondary)	#110	#110		
Needle jet	--	Y-9	Y-8		
Jet needle: US	N10A	4BE4	4BC6		
other than US	--	4BE3	4BC7		
Jet needle clip position:					
US	Non-adjustable	Non-adjustable	Non-adjustable		
other than US	--	3rd groove from top	3rd groove from top		
Pilot jet	#35	#37.5	#37.5		
Pilot screw: US	Non-adjustable	Non-adjustable	Non-adjustable		
other than US	--	2 turns out	2 turns out		
Service fuel level	4 ±1 mm	3 ±1 mm	3 ±1 mm		156,317
Float height	21 ±2 mm	18.6 ±2 mm	18.6 ±2 mm		317,366
Camshafts, Chain:					
Cam height:					
KZ750H, KZ/Z750L	36.245 – 36.353 mm			36.15 mm	157
ZX750A: IN	36.746 – 36.854 mm			36.65 mm	157
EX	35.746 – 35.854 mm			35.65 mm	157
Camshaft bearing oil clearance	0.100 – 0.141 mm			0.23 mm	158
Camshaft journal diameter	21.94 – 21.96 mm			21.91 mm	158
Camshaft bearing inside diameter	22.060 – 22.081 mm			22.14 mm	158
Camshaft runout	--			0.1 mm TIR	158
Cam chain 20-link length	127.00 – 127.36 mm			128.9 mm	159

Item	Standard	Service Limit	See Page
Cylinder Compression:	1,120 – 1,310 kPa (11.4 – 13.4 kg/cm ² , 162 – 191 psi), and less than 98 kPa (1 kg/cm ² , 14 psi) difference between any two cylinders	855 – 1,310 kPa (8.7 – 13.4 kg/cm ² , 124 – 191 psi), or 98 kPa (1 kg/cm ² , 14 psi) difference between any two cylinders	169
Cylinder Head, Valves:			
Valve clearance	0.08 – 0.18 mm	--	13
Cylinder head warp	--	0.05 mm	160
Combustion chamber volume:			
KZ750H	24.8 ±0.4 mL	--	160
KZ/Z750L	25.3 ±0.4 mL	--	160
ZX750A	25.9 ±0.4 mL	--	160
Valve head thickness:			
Inlet	0.8 – 1.2 mm	0.5 mm	161
Exhaust	0.8 – 1.2 mm	0.7 mm	161
Valve stem bend	--	0.05 mm TIR	162
Valve stem diameter	6.95 – 6.97 mm	6.94 mm	162
Valve guide inside diameter	7.000 – 7.015 mm	7.08 mm	163
Valve/valve guide clearance (wobble method):	0.08 – 0.16 mm	0.33 mm	163
Valve seating area outside diameter:			
Inlet	33 mm	--	279
Exhaust	29 mm	--	279
Valve seating area width	0.5 – 1.0 mm	--	279
Valve installed height:			
KZ750H, KZ/Z750L	36.61 – 37.53 mm	--	164
ZX750A: Inlet	36.61 – 37.53 mm	--	164
Exhaust	37.11 – 38.03 mm	--	164
Valve spring free length:			
Inlet	37.25 mm	35.3 mm	
Exhaust	41.85 mm	40.3 mm	
Clean Air System:			
Vacuum switch valve switching pressure:			
Open → Close	50 – 64 kPa (38 – 48 cmHg)		167
Close → Open	49 kPa (37 cmHg)		167
Cylinder Block, Pistons:			
Cylinder inside diameter	66.005 – 66.017 mm, and less than 0.01 mm difference between any two measurements	66.10 mm, or 0.05 mm difference between any two measurements	169
Piston diameter	65.951 – 65.966 mm	65.81 mm	170
Piston/cylinder clearance	0.040 – 0.067 mm	--	170
Piston ring groove width:			
Top	1.02 – 1.04 mm	1.12 mm	171
Second	1.21 – 1.23 mm	1.31 mm	171
Oil	2.50 – 2.52 mm	2.60 mm	171
Piston ring thickness:			
Top	0.970 – 0.990 mm	0.90 mm	171
Second	1.170 – 1.190 mm	1.10 mm	171
Piston ring/groove clearance:			
Top	0.03 – 0.07 mm	0.17 mm	171
Second	0.02 – 0.06 mm	0.16 mm	171
Piston ring end gap (top and second):	0.20 – 0.40 mm (installed in standard cylinder bore)	0.7 mm	171

360 SUPPLEMENT – 1983 MODEL

Item	Standard	Service Limit	See Page														
Crankshaft, Connecting Rods:																	
Connecting rod bend	--	0.2/100 mm	172														
Connecting rod twist	--	0.2/100 mm	173														
Connecting rod bearing insert/ crankpin clearance	0.036 – 0.066 mm	0.10 mm	173														
Crankpin diameter:	34.984 – 35.000 mm	34.97 mm	173														
None	34.984 – 34.994 mm																
○	34.995 – 35.000 mm																
Connecting rod big end inside diameter:	38.000 – 38.016 mm	--	174														
None	38.000 – 38.008 mm																
○	38.009 – 38.016 mm																
Connecting rod big end bearing insert thickness:																	
Brown	1.475 – 1.480 mm	--	174														
Black	1.480 – 1.485 mm	--	174														
Green	1.485 – 1.490 mm	--	174														
Connecting rod bearing insert selection:	KZ750H, KZ/Z750L		174 298														
		<table border="1"> <thead> <tr> <th colspan="2"></th> <th colspan="2">Marking for con-rod big end bore</th> </tr> <tr> <th colspan="2"></th> <th>○</th> <th>None</th> </tr> </thead> <tbody> <tr> <td rowspan="2">Marking for crankpin diameter</td> <td>○</td> <td>Black P/N: 92028-1157 13034-051</td> <td>Blown P/N: 92028-1158 13034-052</td> </tr> <tr> <td>None</td> <td>Green P/N: 92028-1156 13034-050</td> <td>Black P/N: 92028-1157 13034-051</td> </tr> </tbody> </table>			Marking for con-rod big end bore				○	None	Marking for crankpin diameter	○	Black P/N: 92028-1157 13034-051	Blown P/N: 92028-1158 13034-052	None	Green P/N: 92028-1156 13034-050	Black P/N: 92028-1157 13034-051
		Marking for con-rod big end bore															
		○	None														
Marking for crankpin diameter	○	Black P/N: 92028-1157 13034-051	Blown P/N: 92028-1158 13034-052														
	None	Green P/N: 92028-1156 13034-050	Black P/N: 92028-1157 13034-051														
	ZX750A		174,351														
		<table border="1"> <thead> <tr> <th colspan="2"></th> <th colspan="2">Marking for con-rod big end bore</th> </tr> <tr> <th colspan="2"></th> <th>○</th> <th>None</th> </tr> </thead> <tbody> <tr> <td rowspan="2">Marking for crankpin diameter</td> <td>○</td> <td>Black P/N: 92028-1204</td> <td>Brown P/N: 92028-1205</td> </tr> <tr> <td>None</td> <td>Green P/N: 92028-1203</td> <td>Black P/N: 92028-1204</td> </tr> </tbody> </table>			Marking for con-rod big end bore				○	None	Marking for crankpin diameter	○	Black P/N: 92028-1204	Brown P/N: 92028-1205	None	Green P/N: 92028-1203	Black P/N: 92028-1204
		Marking for con-rod big end bore															
		○	None														
Marking for crankpin diameter	○	Black P/N: 92028-1204	Brown P/N: 92028-1205														
	None	Green P/N: 92028-1203	Black P/N: 92028-1204														
Connecting rod big end side clearance	0.13 – 0.33 mm	0.50 mm	174														
Crankshaft runout	--	0.05 mm TIR	174														
Crankshaft main bearing insert/ journal clearance	0.020 – 0.044 mm	0.08 mm	175														
Crankshaft main journal diameter:	35.984 – 36.000 mm	35.96 mm	175														
None	35.984 – 35.992 mm																
○	35.993 – 36.000 mm																
Crankshaft main bearing bore inside diameter:	39.000 – 39.016 mm	--	175														
○	39.000 – 39.008 mm																
None	39.009 – 39.016 mm																

Item	Standard	Service Limit	See Page															
Crankshaft main bearing insert thickness:	Brown	1.490 – 1.494 mm	--	176														
	Black	1.494 – 1.498 mm	--	176														
	Blue	1.498 – 1.502 mm	--	176														
Crankshaft main bearing insert selection	<table border="1" style="margin-left: auto; margin-right: auto;"> <thead> <tr> <th colspan="4">Marking for con-rod big end bore</th> </tr> <tr> <th colspan="2"></th> <th>○</th> <th>None</th> </tr> </thead> <tbody> <tr> <th rowspan="2">Marking for crankshaft journal dia.</th> <th>1</th> <td>Brown P/N: 92028-1102</td> <td>Black P/N: 92028-1101</td> </tr> <tr> <th>None</th> <td>Black P/N: 92028-1101</td> <td>Blue P/N: 92028-1100</td> </tr> </tbody> </table>		Marking for con-rod big end bore						○	None	Marking for crankshaft journal dia.	1	Brown P/N: 92028-1102	Black P/N: 92028-1101	None	Black P/N: 92028-1101	Blue P/N: 92028-1100	176
Marking for con-rod big end bore																		
		○	None															
Marking for crankshaft journal dia.	1	Brown P/N: 92028-1102	Black P/N: 92028-1101															
	None	Black P/N: 92028-1101	Blue P/N: 92028-1100															
Crankshaft side clearance	0.05 – 0.15 mm	0.35 mm	176															
Primary Reduction System: Secondary gear/clutch housing gear backlash	0 – 0.10 mm	0.14 mm	180															
Clutch: Clutch lever play	2 – 3 mm	--	17,346															
Friction plate thickness	3.55 – 3.85 mm	3.4 mm	178															
Friction and steel plate warp	--	0.3 mm	179															
Clutch spring free length	35.0 mm	33.9 mm																
Transmission: Gear backlash	0 – 0.17 mm	0.25 mm	184															
Shift fork ear thickness	4.9 – 5.0 mm	4.8 mm	184															
Gear shift fork groove width	5.05 – 5.15 mm	5.25 mm	184															
Shift fork guide pin diameter:																		
1st, 2nd – 3 rd gear shift fork	7.9 – 8.0 mm	7.8 mm	185															
4th – 5 th gear shift fork	7.985 – 8.000 mm	7.9 mm	185															
Shift drum groove width	8.05 – 8.20 mm	8.3 mm	185															
Engine Lubrication System: Oil pressure @4,000 r/min (rpm), 90°C (194°F) oil temp.	196 – 245 kPa (2.0 – 2.5 kg/cm ² , 28 – 36 psi)		186															
Engine oil: Grade	SE class		18															
Viscosity	SAE 10W40, 10W50, 20W40, or 20W50		18															
Amount	3.5 L		18															
Level	Between upper and lower levels		18															

362 SUPPLEMENT – 1983 MODEL

Chassis:

Item	Standard	Service Limit	See Page																												
Wheels: Wheel balance Tire payload: KZ750H, KZ/Z750L ZX750A	Imbalance of less than 0.1 N (10 g) 1,620 N (165 kg) 1,770 N (180 kg)		27 192 192																												
<p>Standard tires:</p> <p>KZ750H</p> <table border="1" data-bbox="240 690 1032 871"> <thead> <tr> <th>Front</th> <th>Rear</th> </tr> </thead> <tbody> <tr> <td>3.25H19 4 PR Bridgestone Mag. Mopus-L303AW Tubeless</td> <td>130/90-16 67H Bridgestone Mag. Mopus-S716AW or Bridgestone Mag. Mopus-S714W Tubeless</td> </tr> </tbody> </table> <div style="display: flex; justify-content: space-around;"> <div data-bbox="240 984 716 1205"> <p>KZ750L (US, Canada)</p> <table border="1"> <thead> <tr> <th>Front</th> <th>Rear</th> </tr> </thead> <tbody> <tr> <td>100/90-19 57H Dunlop F8 MarkII A or Bridgestone L303A Tubeless, Nylon</td> <td>120/90-18 65 H Dunlop K 427 or Bridgestone G508 Tubeless, Nylon</td> </tr> </tbody> </table> </div> <div data-bbox="816 984 1182 1241"> <p>Z750L (other than US, Canada)</p> <table border="1"> <thead> <tr> <th>Front</th> <th>Rear</th> </tr> </thead> <tbody> <tr> <td>100/90V19 Dunlop F8 MarkII A Tubeless, Nylon</td> <td>120/90V18 Dunlop K427 Tubeless, Nylon</td> </tr> </tbody> </table> </div> </div> <div style="display: flex; justify-content: space-around;"> <div data-bbox="240 1346 630 1535"> <p>ZX750A (US, Canada)</p> <table border="1"> <thead> <tr> <th>Front</th> <th>Rear</th> </tr> </thead> <tbody> <tr> <td>110/90-18 61H Dunlop F17 Tubeless</td> <td>130/80-18 66H Dunlop K427 Tubeless</td> </tr> </tbody> </table> </div> <div data-bbox="816 1346 1198 1539"> <p>ZX750A (other than US, Canada)</p> <table border="1"> <thead> <tr> <th>Front</th> <th>Rear</th> </tr> </thead> <tbody> <tr> <td>110/90V18 Dunlop F17 Tubeless</td> <td>130/80V18 Dunlop K427 Tubeless</td> </tr> </tbody> </table> </div> </div> <p>Air pressure:</p> <p>KZ750H</p> <table border="1" data-bbox="240 1749 850 1946"> <tbody> <tr> <td>Front</td> <td colspan="2">172 kPa (1.75 kg/cm², 25 psi)</td> </tr> <tr> <td rowspan="2">Rear</td> <td>Up to 956 N (97.5 kg) load</td> <td>147 kPa (1.5 kg/cm², 21 psi)</td> </tr> <tr> <td>956 – 1,620 N (97.5 – 165 kg) load</td> <td>172 kPa (1.75 kg/cm², 25 psi)</td> </tr> </tbody> </table>			Front	Rear	3.25H19 4 PR Bridgestone Mag. Mopus-L303AW Tubeless	130/90-16 67H Bridgestone Mag. Mopus-S716AW or Bridgestone Mag. Mopus-S714W Tubeless	Front	Rear	100/90-19 57H Dunlop F8 MarkII A or Bridgestone L303A Tubeless, Nylon	120/90-18 65 H Dunlop K 427 or Bridgestone G508 Tubeless, Nylon	Front	Rear	100/90V19 Dunlop F8 MarkII A Tubeless, Nylon	120/90V18 Dunlop K427 Tubeless, Nylon	Front	Rear	110/90-18 61H Dunlop F17 Tubeless	130/80-18 66H Dunlop K427 Tubeless	Front	Rear	110/90V18 Dunlop F17 Tubeless	130/80V18 Dunlop K427 Tubeless	Front	172 kPa (1.75 kg/cm ² , 25 psi)		Rear	Up to 956 N (97.5 kg) load	147 kPa (1.5 kg/cm ² , 21 psi)	956 – 1,620 N (97.5 – 165 kg) load	172 kPa (1.75 kg/cm ² , 25 psi)	192
Front	Rear																														
3.25H19 4 PR Bridgestone Mag. Mopus-L303AW Tubeless	130/90-16 67H Bridgestone Mag. Mopus-S716AW or Bridgestone Mag. Mopus-S714W Tubeless																														
Front	Rear																														
100/90-19 57H Dunlop F8 MarkII A or Bridgestone L303A Tubeless, Nylon	120/90-18 65 H Dunlop K 427 or Bridgestone G508 Tubeless, Nylon																														
Front	Rear																														
100/90V19 Dunlop F8 MarkII A Tubeless, Nylon	120/90V18 Dunlop K427 Tubeless, Nylon																														
Front	Rear																														
110/90-18 61H Dunlop F17 Tubeless	130/80-18 66H Dunlop K427 Tubeless																														
Front	Rear																														
110/90V18 Dunlop F17 Tubeless	130/80V18 Dunlop K427 Tubeless																														
Front	172 kPa (1.75 kg/cm ² , 25 psi)																														
Rear	Up to 956 N (97.5 kg) load	147 kPa (1.5 kg/cm ² , 21 psi)																													
	956 – 1,620 N (97.5 – 165 kg) load	172 kPa (1.75 kg/cm ² , 25 psi)																													

Item	Standard	Service Limit	See Page																																																		
<p>KZ/Z750L</p> <table border="1" data-bbox="331 386 943 583"> <tr> <td>Front</td> <td colspan="2">196 kPa (2.00 kg/cm², 28 psi)</td> </tr> <tr> <td rowspan="2">Rear</td> <td>Up to 956 N (97.5 kg) load</td> <td>221 kPa (2.25 kg/cm², 32 psi)</td> </tr> <tr> <td>956 – 1,620 N (97.5 – 165 kg) load</td> <td>245 kPa (2.50 kg/cm², 36 psi)</td> </tr> </table> <div style="display: flex; justify-content: space-around;"> <div data-bbox="331 653 799 913"> <p>ZX750A (US, Canada)</p> <table border="1"> <tr> <td>Front</td> <td colspan="2">196 kPa (2.00 kg/cm², 28 psi)</td> </tr> <tr> <td rowspan="2">Rear</td> <td>Up to 956 N (97.5 kg) load</td> <td>221 kPa (2.25 kg/cm², 32 psi)</td> </tr> <tr> <td>956 – 1,770 N (97.5 – 180 kg) load</td> <td>245 kPa (2.50 kg/cm², 36 psi)</td> </tr> </table> </div> <div data-bbox="889 653 1360 1094"> <p>ZX750A (other than US, Canada)</p> <table border="1"> <tr> <td rowspan="2">Front</td> <td>Up to 1,470 N (150 kg) load</td> <td>196 kPa (2.00 kg/cm², 28 psi)</td> </tr> <tr> <td>Over 210 km/h</td> <td>221 kPa (2.25 kg/cm², 32 psi)</td> </tr> <tr> <td rowspan="3">Rear</td> <td>Up to 956 N (97.5 kg) load</td> <td>221 kPa (2.25 kg/cm², 32 psi)</td> </tr> <tr> <td>956 – 1,770 N (97.5 – 180 kg) load</td> <td>245 kPa (2.50 kg/cm², 36 psi)</td> </tr> <tr> <td>Over 210 km/h</td> <td>284 kPa (2.90 kg/cm², 41 psi)</td> </tr> </table> </div> </div>				Front	196 kPa (2.00 kg/cm ² , 28 psi)		Rear	Up to 956 N (97.5 kg) load	221 kPa (2.25 kg/cm ² , 32 psi)	956 – 1,620 N (97.5 – 165 kg) load	245 kPa (2.50 kg/cm ² , 36 psi)	Front	196 kPa (2.00 kg/cm ² , 28 psi)		Rear	Up to 956 N (97.5 kg) load	221 kPa (2.25 kg/cm ² , 32 psi)	956 – 1,770 N (97.5 – 180 kg) load	245 kPa (2.50 kg/cm ² , 36 psi)	Front	Up to 1,470 N (150 kg) load	196 kPa (2.00 kg/cm ² , 28 psi)	Over 210 km/h	221 kPa (2.25 kg/cm ² , 32 psi)	Rear	Up to 956 N (97.5 kg) load	221 kPa (2.25 kg/cm ² , 32 psi)	956 – 1,770 N (97.5 – 180 kg) load	245 kPa (2.50 kg/cm ² , 36 psi)	Over 210 km/h	284 kPa (2.90 kg/cm ² , 41 psi)																						
Front	196 kPa (2.00 kg/cm ² , 28 psi)																																																				
Rear	Up to 956 N (97.5 kg) load	221 kPa (2.25 kg/cm ² , 32 psi)																																																			
	956 – 1,620 N (97.5 – 165 kg) load	245 kPa (2.50 kg/cm ² , 36 psi)																																																			
Front	196 kPa (2.00 kg/cm ² , 28 psi)																																																				
Rear	Up to 956 N (97.5 kg) load	221 kPa (2.25 kg/cm ² , 32 psi)																																																			
	956 – 1,770 N (97.5 – 180 kg) load	245 kPa (2.50 kg/cm ² , 36 psi)																																																			
Front	Up to 1,470 N (150 kg) load	196 kPa (2.00 kg/cm ² , 28 psi)																																																			
	Over 210 km/h	221 kPa (2.25 kg/cm ² , 32 psi)																																																			
Rear	Up to 956 N (97.5 kg) load	221 kPa (2.25 kg/cm ² , 32 psi)																																																			
	956 – 1,770 N (97.5 – 180 kg) load	245 kPa (2.50 kg/cm ² , 36 psi)																																																			
	Over 210 km/h	284 kPa (2.90 kg/cm ² , 41 psi)																																																			
<p>Tire tread depth:</p> <table border="1"> <tr> <td>Front:</td> <td>KZ750H</td> <td>3.8 mm</td> <td rowspan="3">1 mm</td> <td rowspan="3">192</td> </tr> <tr> <td></td> <td>KZ/Z750L</td> <td>3.5 mm</td> </tr> <tr> <td></td> <td>ZX750A</td> <td>4.5 mm</td> </tr> <tr> <td>Rear:</td> <td>US, Canada</td> <td></td> <td rowspan="3">2 mm</td> <td rowspan="3">192</td> </tr> <tr> <td></td> <td>KZ750H</td> <td>6.7 mm</td> </tr> <tr> <td></td> <td>KZ750L</td> <td>7.3 mm</td> </tr> <tr> <td></td> <td>ZX750A</td> <td>6.9 mm</td> <td></td> <td></td> </tr> <tr> <td></td> <td>Other than US, Canada</td> <td></td> <td rowspan="2">2 mm, Under 130 km/h</td> <td rowspan="2">192</td> </tr> <tr> <td></td> <td>Z750L</td> <td>7.3 mm</td> </tr> <tr> <td></td> <td>ZX750A</td> <td>6.9 mm</td> <td>3 mm, Over 130 km/h</td> <td>192</td> </tr> <tr> <td>Rim runout:</td> <td>Axial</td> <td>---</td> <td>0.5 mm TIR</td> <td>195</td> </tr> <tr> <td></td> <td>Radial</td> <td>---</td> <td>0.8 mm TIR</td> <td>195</td> </tr> </table>				Front:	KZ750H	3.8 mm	1 mm	192		KZ/Z750L	3.5 mm		ZX750A	4.5 mm	Rear:	US, Canada		2 mm	192		KZ750H	6.7 mm		KZ750L	7.3 mm		ZX750A	6.9 mm				Other than US, Canada		2 mm, Under 130 km/h	192		Z750L	7.3 mm		ZX750A	6.9 mm	3 mm, Over 130 km/h	192	Rim runout:	Axial	---	0.5 mm TIR	195		Radial	---	0.8 mm TIR	195
Front:	KZ750H	3.8 mm	1 mm	192																																																	
	KZ/Z750L	3.5 mm																																																			
	ZX750A	4.5 mm																																																			
Rear:	US, Canada		2 mm	192																																																	
	KZ750H	6.7 mm																																																			
	KZ750L	7.3 mm																																																			
	ZX750A	6.9 mm																																																			
	Other than US, Canada		2 mm, Under 130 km/h	192																																																	
	Z750L	7.3 mm																																																			
	ZX750A	6.9 mm	3 mm, Over 130 km/h	192																																																	
Rim runout:	Axial	---	0.5 mm TIR	195																																																	
	Radial	---	0.8 mm TIR	195																																																	
<p>Drive Train:</p> <table border="1"> <tr> <td>Drive chain slack:</td> <td></td> <td></td> <td></td> <td></td> </tr> <tr> <td></td> <td>KZ750H, KZ/Z750L</td> <td>20 – 30 mm</td> <td>20 – 35 mm</td> <td>23</td> </tr> <tr> <td></td> <td>ZX750A</td> <td>35 – 40 mm</td> <td>35 – 45 mm</td> <td>347</td> </tr> <tr> <td>Drive chain 20-link length</td> <td></td> <td>381.0 – 382.0 mm</td> <td>389 mm</td> <td>198</td> </tr> <tr> <td>Front sprocket diameter:</td> <td></td> <td></td> <td></td> <td></td> </tr> <tr> <td></td> <td>KZ750H, KZ/Z750L</td> <td>66.9 – 67.1 mm</td> <td>66.2 mm</td> <td>199</td> </tr> <tr> <td></td> <td>ZX750A</td> <td>70.0 – 70.0 mm</td> <td>70.2 mm</td> <td>199</td> </tr> </table>				Drive chain slack:						KZ750H, KZ/Z750L	20 – 30 mm	20 – 35 mm	23		ZX750A	35 – 40 mm	35 – 45 mm	347	Drive chain 20-link length		381.0 – 382.0 mm	389 mm	198	Front sprocket diameter:						KZ750H, KZ/Z750L	66.9 – 67.1 mm	66.2 mm	199		ZX750A	70.0 – 70.0 mm	70.2 mm	199															
Drive chain slack:																																																					
	KZ750H, KZ/Z750L	20 – 30 mm	20 – 35 mm	23																																																	
	ZX750A	35 – 40 mm	35 – 45 mm	347																																																	
Drive chain 20-link length		381.0 – 382.0 mm	389 mm	198																																																	
Front sprocket diameter:																																																					
	KZ750H, KZ/Z750L	66.9 – 67.1 mm	66.2 mm	199																																																	
	ZX750A	70.0 – 70.0 mm	70.2 mm	199																																																	

364 SUPPLEMENT – 1983 MODEL

Item	Standard	Service Limit	See Page
Rear sprocket diameter:			
KZ750H	182.49 – 182.99 mm	182.2 mm	199
KZ/Z750L	188.32 – 188.82 mm	188.0 mm	199
ZX750A	218.83 – 219.33 mm	218.5 mm	199
Rear sprocket warp	---	0.5 mm TIR	199
Disc Brake:			
Brake fluid grade	DOT 3	---	205
Pad lining thickness:			
Front: KZ750H, KZ/Z750L	3.35 mm	1 mm	203
ZX750A	4.85 mm	1 mm	203
Rear:	4.85 mm	1 mm	203
Disc warp	---	0.3 mm TIR	205
Disc thickness: Front	4.8 – 5.1 mm	4.5 mm	205
Rear	6.8 – 7.1 mm	6.0 mm	205
Brake pedal position: KZ750H	4 – 8 mm		24
KZ/Z750L	14 – 18 mm		293
ZX750A	50.5 – 54.5 mm		293
Brake light switch operation:			
Front	Non-adjustable		25
Rear	On after about 15 mm pedal travel		25
Front Fork:			
Air pressure: KZ750H	49 – 98 kPa (0.5 – 1.0 kg/cm ² , 7.1 – 14 psi)		22
KZ/Z750L	59 – 88 kPa (0.6 – 0.9 kg/cm ² , 8.5 – 13 psi)		22
ZX750A	39 – 59 kPa (0.4 – 0.6 kg/cm ² , 5.7 – 8.5 psi)		292
Oil viscosity	SAE10W		
Oil amount: KZ750H	312 ±4 mL		212
KZ/Z750L	297 ±4 mL		212
ZX750A	248.5 ±4 mL		212
Oil level: KZ750H	438 ±2 mm (Extended)		212
KZ/Z750L	103 ±2 mm (Compressed)		212
ZX750A	185 ±2 mm (Compressed)		212
Rear Shock Absorber (ZX750A):			
Air pressure	49 – 294 kPa (0.5 – 3.0 kg/cm ² , 7.1 – 43 psi)		346

Electrical Equipment:

Item	Standard	Service Limit	See Page
Battery (ZX750A):			
Electrolyte level sensor resistance	600 – 750 Ω		381
Charging System:			
Regulator/rectifier output voltage	Battery voltage – 15 V		223
Alternator output @4,000 r/min (rpm), no load	About 50 V		223
Stator coil resistance	0.48 – 0.72 Ω		223

Item	Standard	Service Limit	See Page
Ignition System:			
Spark plug: Electrode gap	0.7 – 0.8 mm		12
Type: KZ750H, KZ/Z750L ZX750A	NGK BR8ES or ND W24ESR-U NGK B8ES or ND W24ES-U (A)(I)(N)(S)(U) NGK BR9ES or ND W27ESR-U NGK B9ES or ND W27ES-U (A)(I)(N)(S)(U)		12 12 12
Low speed riding:			
KZ750H, KZ/Z750L ZX750A	NGK BR7ES or ND W22ESR-U NGK B7ES or ND W22ES-U (A)(I)(N)(S)(U) NGK BR8ES or ND W24ESR-U NGK B8ES or ND W24ES-U (A)(I)(N)(S)(U)		12 12 12
Ignition coil:			
Arcing distance (3-needle method)	7 mm or more		230
Primary winding resistance	1.8 – 2.8 Ω		230
Secondary winding resistance	10 – 16 kΩ		230
Pickup coil resistance:			
KZ750H, KZ/Z750L	360 – 540 Ω		231
ZX750A	380 – 560 Ω		373
Electric Starter System:			
Starter motor carbon brush length	12.0 – 12.5 mm	6 mm	234
Fuel Gauge:			
Fuel level sensor resistance:			
Full	1 – 5 Ω		327
Empty	103 – 117 Ω		327

(A) : Australian Model

(I) : Italian Model

(N) : Norwegian Model

(S) : South African Model

(U) : U.S. Model

366 SUPPLEMENT – 1983 MODEL

Air Cleaner Element (KZ750H)

The air cleaner element on the 1983 KZ750H is the oiled type element. Refer to the informations for the oiled type element on p. 312.

Carburetors (KZ750H)

Refer to p. 150 – 157, p. 358, noting the following.

Measuring Float Height – Keihin Carburetors

N122

382120

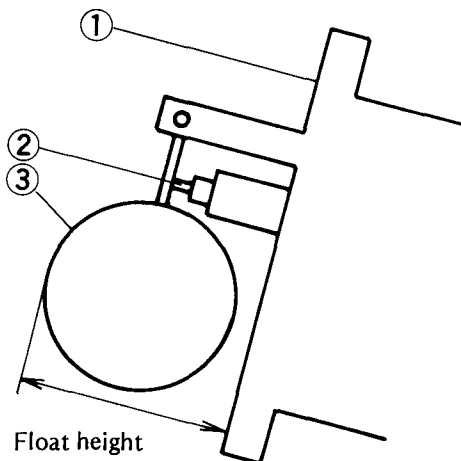

1. Float bowl mating surface
2. Float valve needle rod (contacted but unloaded)
3. Float

Disc Brakes (ZX750A)

Refer to p. 200 – 208, noting the following.

Brake Fluid:

Brake Fluid Change

- Using the bleed valves on the anti-dive units, drain the brake fluid from the front brake line as well as the disc

Brake Line Air Bleeding

- Bleed the air from the front brake line, first using the bleed valves on the brake calipers and the anti-dive units, and then using the bleed valves on the junction blocks.

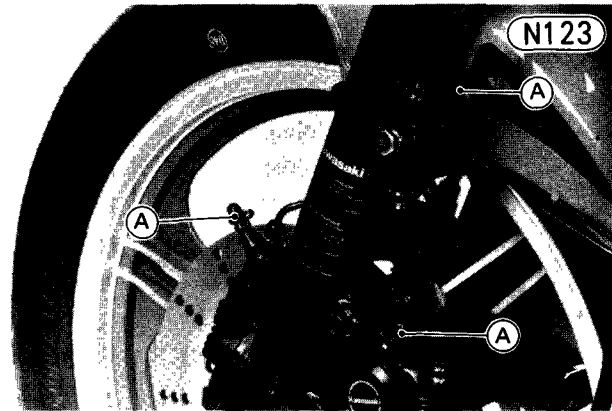

A. Bleed valve

Front Fork (ZX750A)

Refer to p. 209 – 213, p. 318 – 319, noting the following.

Spring Force – Fork Assy (ZX750A)

N124

482107

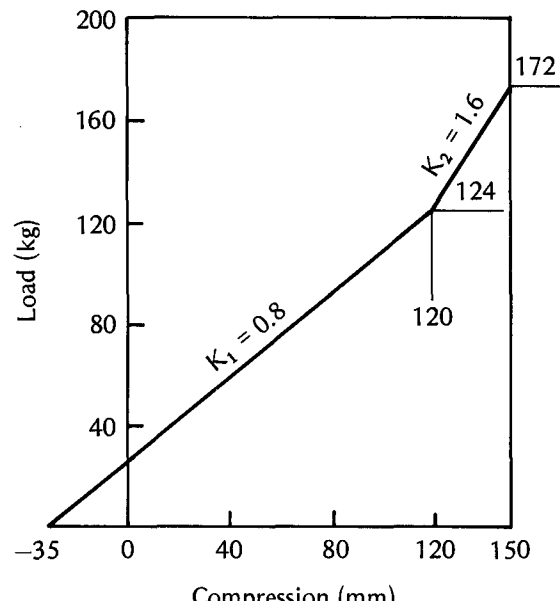

Anti-Dive System:

“NOTE”

○Do not disassemble the anti-dive valve assembly for repair or replacement of internal parts. Always replace it as an assembly.

Brake Fluid and Fork Oil Leak Inspection

- Visually inspect the anti-dive unit for brake fluid and fork oil leak.
- ★If the brake fluid leaks, replace the brake plunger assembly.
- ★If the fork oil leaks, replace the O-rings or anti-dive valve assembly.

Brake Plunger Assembly Test

The brake plunger assembly can be tested by separating it from the anti-dive valve assembly with the brake line connected to the brake pipe assembly.

- Separate the brake plunger assembly from the anti-dive valve assembly.
- Unbolt the brake line junction from the fork leg to prevent the metal pipe from being deformed.
- Check to see if the plunger in the brake plunger assembly comes out by a 2 mm when the front brake is lightly applied, and check to see if the plunger goes in smoothly when it is pushed on in with your finger.
- ★If the plunger does not move lightly or it has stuck in the body, replace the brake plunger assembly.



A. Brake Plunger

Anti-Dive Valve Assembly Test

The operation of the anti-dive valve assembly can be checked by removing the front fork leg from the motorcycle.

- Separate the brake plunger assembly from the anti-dive valve assembly with the brake line connected.
- Unscrew the top bolt and take the fork main spring

- Remove the front wheel, disc brake caliper, from fender and brake line junction from the fork leg
- Remove the front fork leg with its anti-dive valve assembly installed and tape the equalizing hole in the fork inner tube to prevent the fork oil from flowing out during anti-dive valve assembly test.
- With the fork leg held upright, compress the fork leg and see that the compression stroke is light and smooth when the valve rod is not pushed in and that there is notable damping when the valve rod is pushed in with your finger.

“NOTE”

○The extension stroke should be smooth with the notable damping regardless of valve rod positions

- ★If the fork leg has heavy compression stroke when the valve rod is left released, or if it has light compression stroke when the rod is pushed in; the anti-dive valve assembly does not operate properly necessitating replacement of the anti-dive valve assembly.

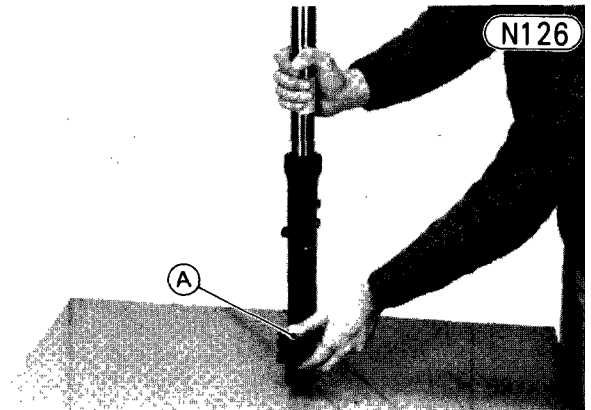

A. Valve rod

Metal Pipe Damage

- The metal pipes which feed the brake fluid to the anti-dive units are made of plated steel, and will rust if the plating is damaged. Replace the pipe if it is rusted, cracked (especially check the fittings), or if the plating is badly scratched.

Replacement of Anti-Dive System Parts

In accordance with the Periodic Maintenance Chart, replace the following anti-dive system parts.

Periodic Replacement Parts of Anti-Dive System

Brake plunger assemblies

368 SUPPLEMENT – 1983 MODEL

●Be sure to bleed the air from the brake line after replacement.

.....
Rear Shock Absorbers (KZ/Z750L)

Refer to p. 213 – 214, noting the following.

**Spring Force – One Shock Unit
 (KZ750L US, Canada Models)**

(N127)

482108

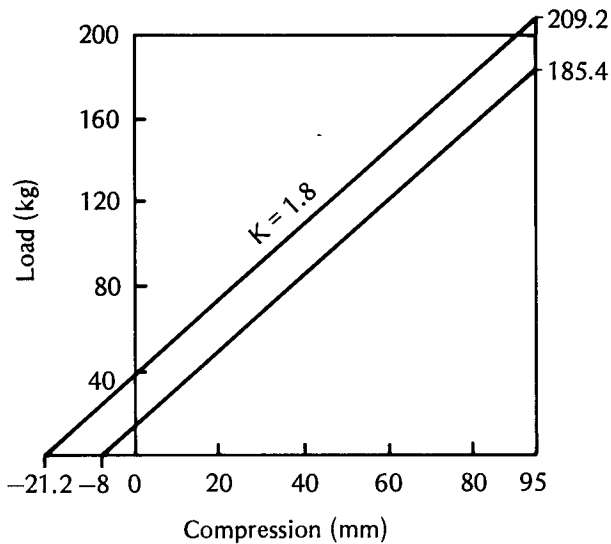

.....
Rear Shock Absorber (ZX750A)

**Spring Force – Shock Absorber
 (US and Canada)**

(N128)

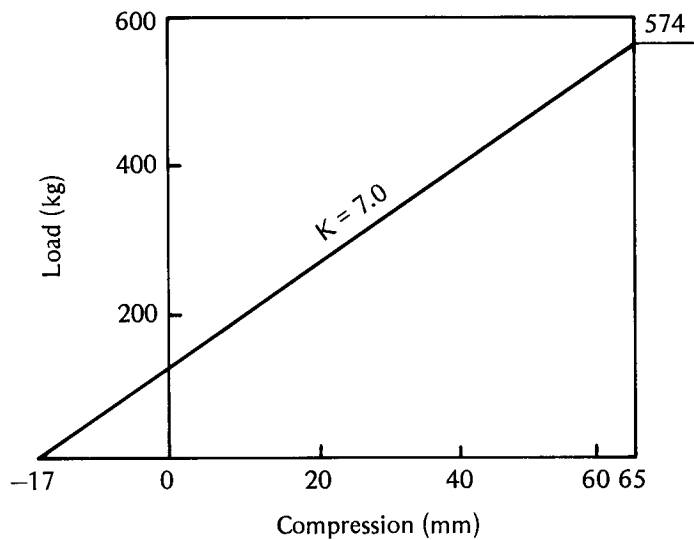

**Spring Force – Shock Absorber
 (Other than US and Canada)**

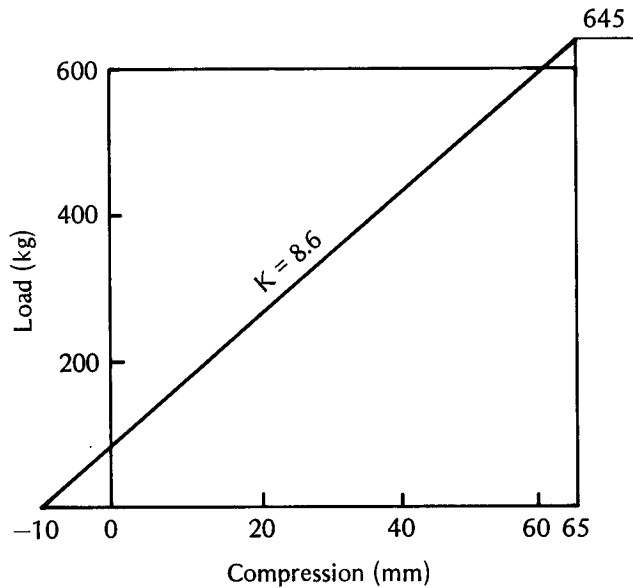

482109

.....
**Swing Arm (ZX750A)
 Uni-Trak (ZX750A)**

Lubrication

In order for the swing arm and uni-trak to function safely and wear slowly, it should be lubricated in

- Remove the rear wheel and swing arm.
- Remove the uni-trak rocker arm and tie rods.
- Remove the dust seal for the swing arm right side pivot, and remove the ball bearing from the right side of the swing arm pivot.
- Pull out the sleeves out of the bearings.
- Using a high flash-point solvent, wash the sleeves, needle bearings, spherical bearings, and ball bearing of old grease, and dry them.
- Inspect the bearings, sleeves, and dust seals.
- Apply a molybdenum disulfide chassis assembly grease to the needle bearings and sleeves.
- Pack the ball bearing and spherical bearings with the same grease.
- Using a new dust seal on the swing arm right side pivot, assemble the uni-trak rocker arm and tie rods.
- Install the swing arm and rear wheel.

Inspection

- Check the sleeves, needle bearings, ball bearing, spherical bearings, and/or dust seals for abrasions, color change, or other damage.
- ★ If there are any doubt as to the condition, replace the damaged parts with new ones. If either needle bearing or sleeve is damaged, replace them as a set.

- ★ The resistance should be low in one direction and more than ten times as much in the other direction. If any diode shows low or high in both directions, the diode is defective and the diode assembly must be replaced.

“NOTE”

- The actual meter reading varies with the meter used and the individual diode, but, generally speaking, the lower reading should be from zero to the first ½ of the scale.

Polarity of Diode

N129

582520

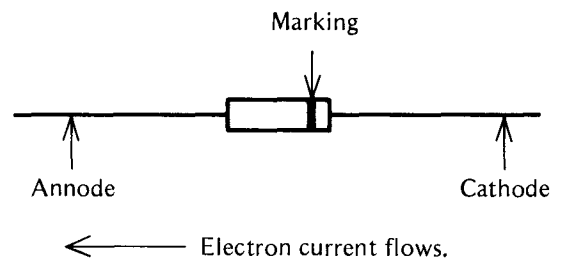

Inspecting Fuse

- Remove the fuse from the junction box.
- Inspect the fuse element for blowout.
- ★ If it has been blown out, replace the fuse.

Fuse

N130

582521

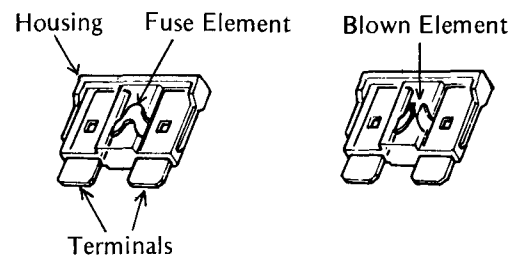

Junction Box (ZX750A)

The junction box contains compactly following electrical components in a small room:

- Fuses
- Relays
- Diodes
- ACC 2-Pin Connector



- **Special care must be taken during removal and installation of the junction box electrical components. Refer to disassembly chapter.**

Inspecting Diodes

- Disconnect the diode assembly from the junction box.
- Zero the ohmmeter, and connect it to each diode leads

Testing Main, Starter Circuit, and Headlight Relays

- Remove the relay from the junction box.
- Connect the ohmmeter and one 12-volt battery to the relay as shown.
- ★ If the relay does not work as specified, the relay is defective.

Testing Relay

Meter range:	1 Ω range
Criteria:	When battery is connected → 0 Ω

370 SUPPLEMENT – 1983 MODEL

Testing Relay

582522

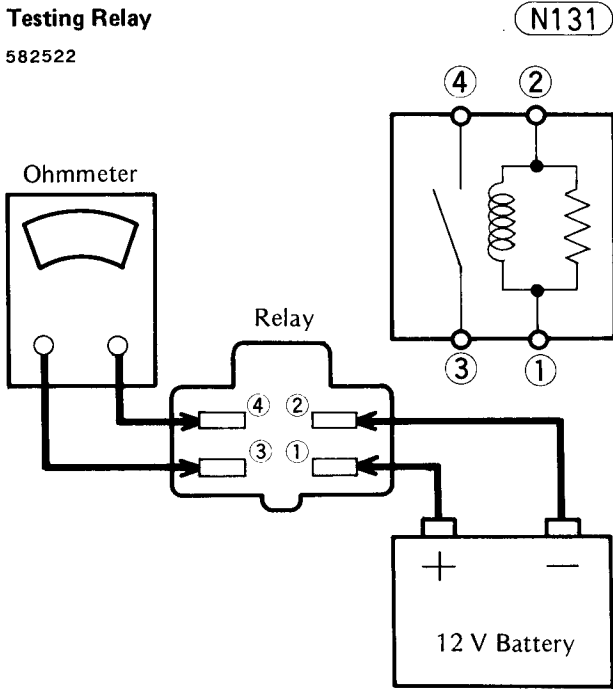

① and ② : Relay Coil Terminals
③ and ④ : Relay Switch Terminals

Testing Turn Signal

The Number of Turn Signal Lights	Load	
	Wattage (W)	Flashing Times (c/m*)
1	21 – 23	More than 150
2	42 – 46	75 – 95
3	63 – 69	
4	84 – 92	

* : Cycle(s) per minute

Inspecting Junction Box Internal Circuit

- Remove the junction box from the motorcycle.
- Disconnect all the fuses, relays, diode assemblies, and connectors from the junction box.
- Make sure all connector terminals are clean and tight, and none of them have been bent.
- ★ Clean the dirty terminals, and correct lightly-bent terminals.
- Check conductivity of the internal circuit. Both terminals of the same number should conduct, and the differently numbered terminals should not conduct.
- ★ If there are open or short circuit, replace the junction box.

Testing Turn Signal Relay

- Remove the turn signal relay from the junction box.
- Connect one 12-volt battery and turn signal lights as indicated in the figure, and count how many times the lights flash for one minute.
- ★ If the lights do not flash as specified, replace the turn signal relay.

**Testing Turn Signal Relay
(Example: Two lights are connected.)**

(N132)

582523

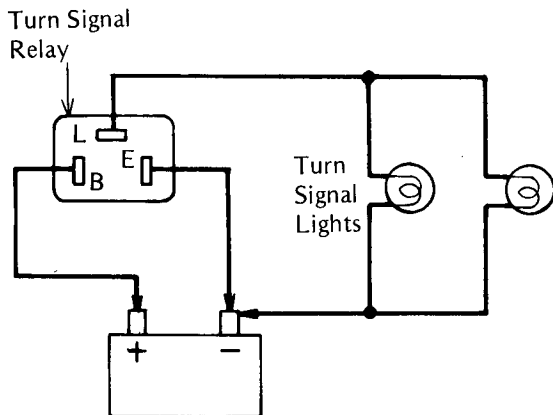

Charging System (ZX750A)

Refer to p. 220 – 225, noting the following.

Regulator/Rectifier Inspection

Regulator Test

582122

(N133)

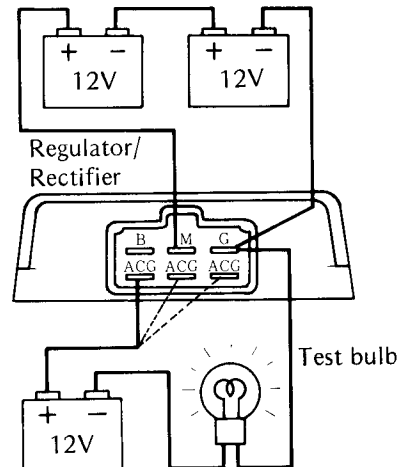

B. B (Battery) terminal
M. M (Monitor) terminal
G. G (Ground) terminal

Junction Box Internal Wiring Diagram

N134

582524

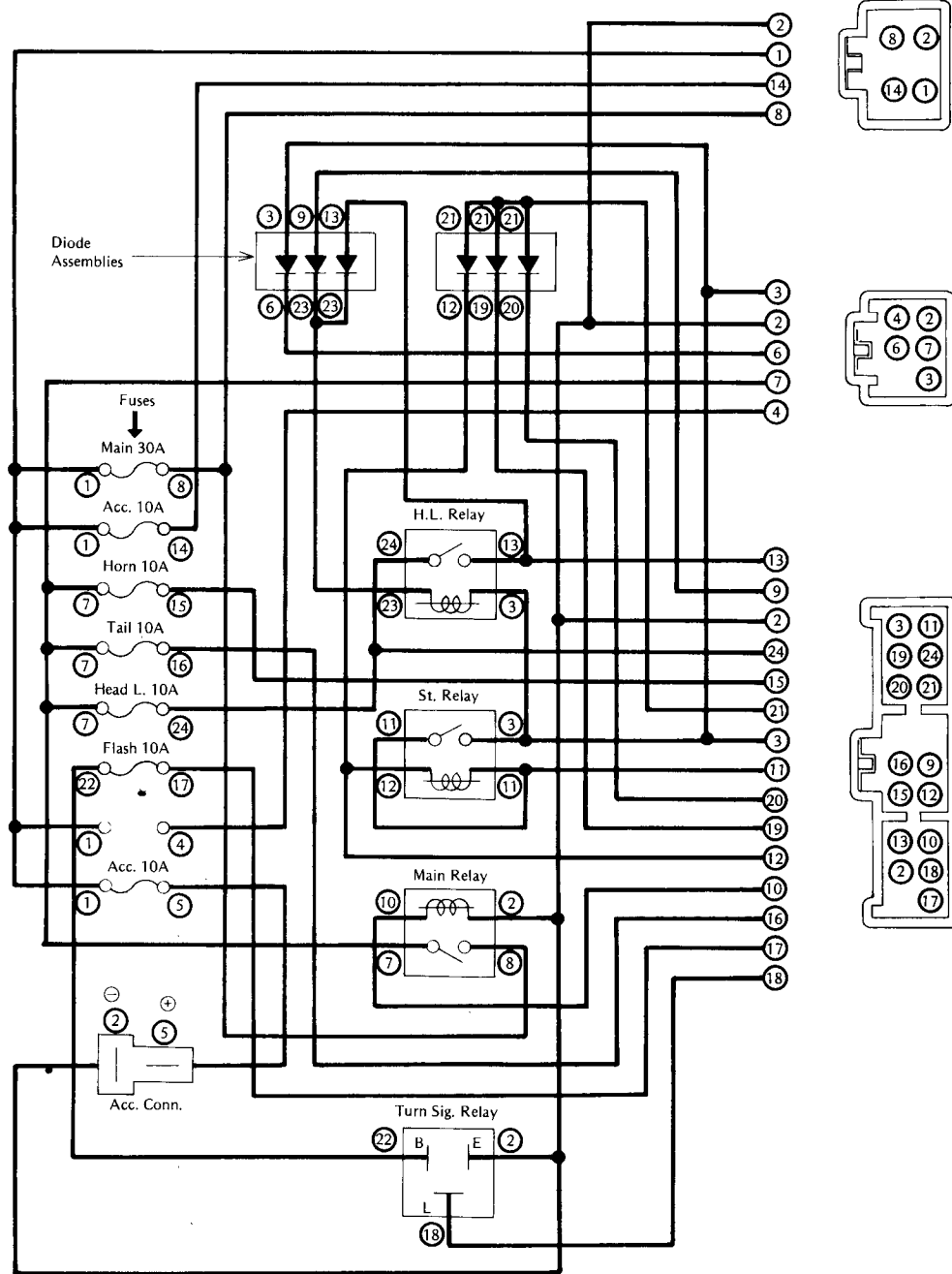

.....
Ignition System (ZX750A)

Introduction:

The ignition system for this model is essentially a battery and coil ignition system where the battery supplies the current for the primary circuit in the ignition system. The current for the primary circuit is controlled by use of an electronic switch called a power transistor. Moreover, the ignition timing is advanced not by a centrifugal advance mechanism but by an electronic

Since there are no moving mechanical parts to wear out, periodic inspection and adjustment of the ignition timing are not required. The working electrical part of the ignition system consists of a battery, two pickup coils, an IC igniter, two ignition coils, and four spark plugs. Except when side stand is left down, clutch lever is released, and gears are not in neutral each spark plug fires every time the piston rises. However, if a spark does jump across the electrodes during the exhaust stroke, it has no effect on engine operation since there is

Safety Instruction:

There are a number of important precautions that must be observed when servicing the transistorized ignition system. Failure to observe these precautions can result in serious system damage. Learn and observe all the rules listed below.

- (1) Because of limited capacity of the voltage regulating circuit in the IC igniter, do not disconnect the battery leads or any other electrical connections when the ignition switch is on, or while the engine is running. This is to prevent IC igniter damage.
- (2) Do not install the battery backwards. The negative side is grounded. This is to prevent damage to the diodes and IC igniter.

Ignition System Inspection:

If trouble is suspected in the ignition system, check the following items. Before inspecting these items, make sure that all connectors and leads in the ignition system are clean, tight, and in good condition.

1. Dynamic Ignition Timing Inspection
2. Checking Power Supply to IC Igniter
3. Ignition Coil Inspection
4. Pickup Coil Inspection
5. IC Igniter Inspection
6. Switches Inspection

“NOTE”

○Refer to the “Junction Box” section for the junction box, diodes, and fuse inspection.

Dynamic Ignition Timing Inspection

Check the ignition timing with a strobe light for both low and high speed operations.

Ignition Timing/Engine Speed Relationship

582124

N136

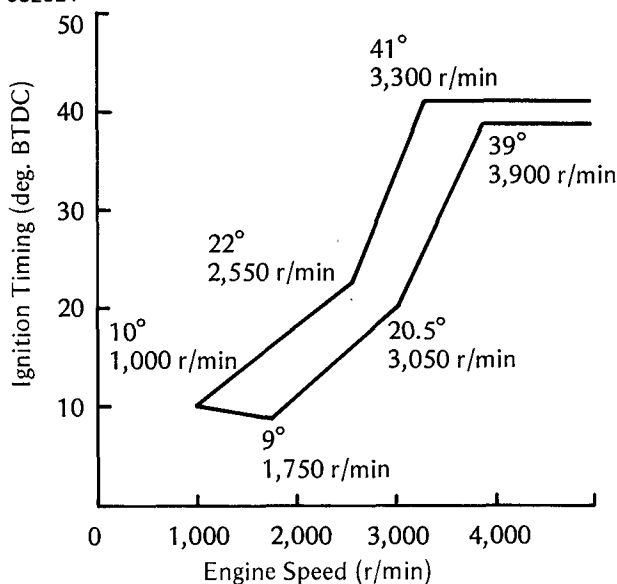

- Connect strobe light to the #1 or #4 spark plug lead in the manner prescribed by the manufacturer in order to check the ignition timing under operating conditions.
- Start the engine, and direct the strobe light at the timing marks.

Checking Engine Speed

Low Speed:	Idle speed
High Speed:	Above 3,900 r/min (rpm)

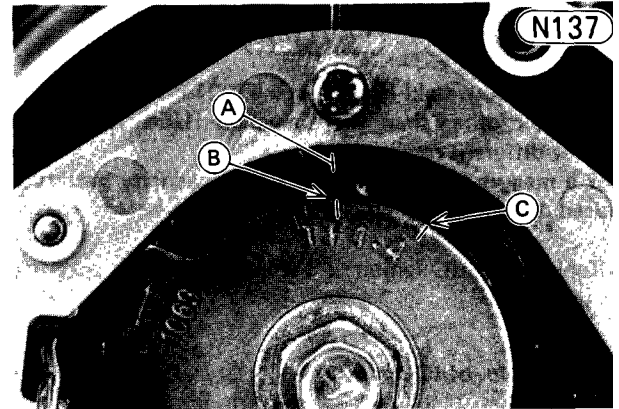

- A. Timing mark
- B. “F” mark
- C. Advanced mark

- ★At low speed, the “F” mark on the timing rotor should be aligned with the timing mark on the engine.
- ★At high speed, the timing mark on the engine should be aligned with the advanced timing mark.

Checking Power Supply to IC Igniter

- Disconnect the IC igniter 10-pin connector.
- Using the voltmeter, check the voltage of the power supply leads.

Checking Power Supply to IC Igniter

Switch Position:	Ignition switch ON Engine stop switch RUN
Voltmeter Connections:	
Lead location	Female IC igniter 10-pin connector
Meter range	25 V DC
Meter (+) →	Red lead
Meter (-) →	Black/yellow lead
Meter Reading:	Battery voltage

- ★If the battery power does not reach the IC igniter inspect the power supply circuit.
 - Junction Box
 - Fuse (main)
 - Diodes
 - Switches (ignition, engine stop/starter)
 - Wires and Connectors

Ignition Coil Inspection

Refer to p. 230.

Pickup Coil Inspection

Refer to p. 231 – 232 and p. 365, noting the following.

- Check the pickup coil air gaps (clearance between timing rotor projection and the pickup coil core).
- ★If both air gaps are not equal, reposition the pickup coil.

374 SUPPLEMENT – 1983 MODEL

IC Igniter Inspection

- Remove the IC igniter.
- Zero the ohmmeter, and connect it to terminals of the IC igniter to check the internal resistance of the igniter.

CAUTION

- Use only Kawasaki Hand Tester 57001-983 for this test. A tester other than the Kawasaki Hand Tester may show different readings.
- If a megger or a meter with a large-capacity battery is used, the IC igniter will be damaged.

★ Replace the IC igniter if the reading is not specified value.

Terminal No. of IC Igniter

582125

N138

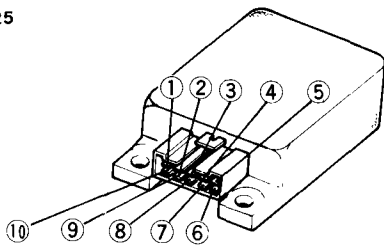

Switches Inspection

- Using the ohmmeter, check to see that only the connections shown in the table have continuity (about zero ohms).

★ If the switch has open or a short, repair it or replace it with new one.

Engine Stop Switch Connections

	R	Y/R
OFF		
RUN	○	○

Side Stand Switch Connections

	G/W	BR
When the side stand is left up	○	○
When the side stand is left down		

Starter Lockout Switch Connections

	BK/Y	Y/G	LG
When the clutch lever is pulled in	○	○	
When the clutch lever is released			○

Neutral Switch Connections

	LG	///
When the gears are in neutral	○	○
When the gears are not in neutral		

Ignition Switch Connections

	BR	W	Y	BL	R	W/BK	O/G
OFF, LOCK							
ON	○	○	○	○	○	○	○
P(Park)		○	○	○	○	○	○
						Only on US	

IC Igniter Internal Resistance

		Tester (+) Lead Connection										
		Terminal Number	1	2	3	4	5	6	7	8	9	10
Tester (-) Lead Connection	1		D	D	D	D	D	D	D	D	D	∞
	2	D		D	D	D	D	D	D	D	D	∞
	3	C	C		B	B	B	B	B	B	B	∞
	4	∞	∞	∞		∞	∞	∞	∞	∞	∞	∞
	5	∞	∞	∞	∞		∞	∞	∞	∞	∞	∞
	6	C	C	B	A	A		A	O	O	O	∞
	7	C	C	B	A	A	A		A	A	A	∞
	8	C	C	B	A	A	O	A		O	O	∞
	9	C	C	B	A	A	O	A	O		O	∞
	10	∞	∞	∞	∞	∞	∞	∞	∞	∞	∞	

Value (kΩ)	
O	Zero
A	0.3 – 4.2
B	6.6 – 21.4
C	25 – 75
D	125 – 375
∞	Infinity

Measured with the Kawasaki Hand Tester 57001-983.

Electric Starter System (ZX750A)

Checking Power Supply to Starter Relay

- Remove the left side cover and disconnect the 2-pin connector from the starter relay.
- Using a multimeter, check the voltage of the power supply wires.
- ★ If the meter does not show the specified reading, inspect the power supply and ground side circuits.
 - Junction box
 - Fuse (main)
 - Relay (starter circuit)
 - Switches (ignition, engine stop/starter, starter lockout, and/or neutral)
 - Wires and connectors
- ★ If the meter shows the specified reading, inspect the starter relay and/or starter motor.

Power Supply Inspection

Switch Position:	
Ignition switch	ON
Engine stop/starter switch	ON (Pushed with RUN)
Starter lockout switch	ON (when clutch lever released and neutral switch ON) or OFF (when clutch lever pulled in and neutral switch OFF)
Meter Connections:	
Meter range	25 V DC
Wire location	Female 2-pin connector (disconnected)
Meter (+) →	Yellow/red wire
Meter (-) →	Black/yellow wire
Meter Reading:	Battery Voltage

Electric Starter Circuit

(N139)

582126

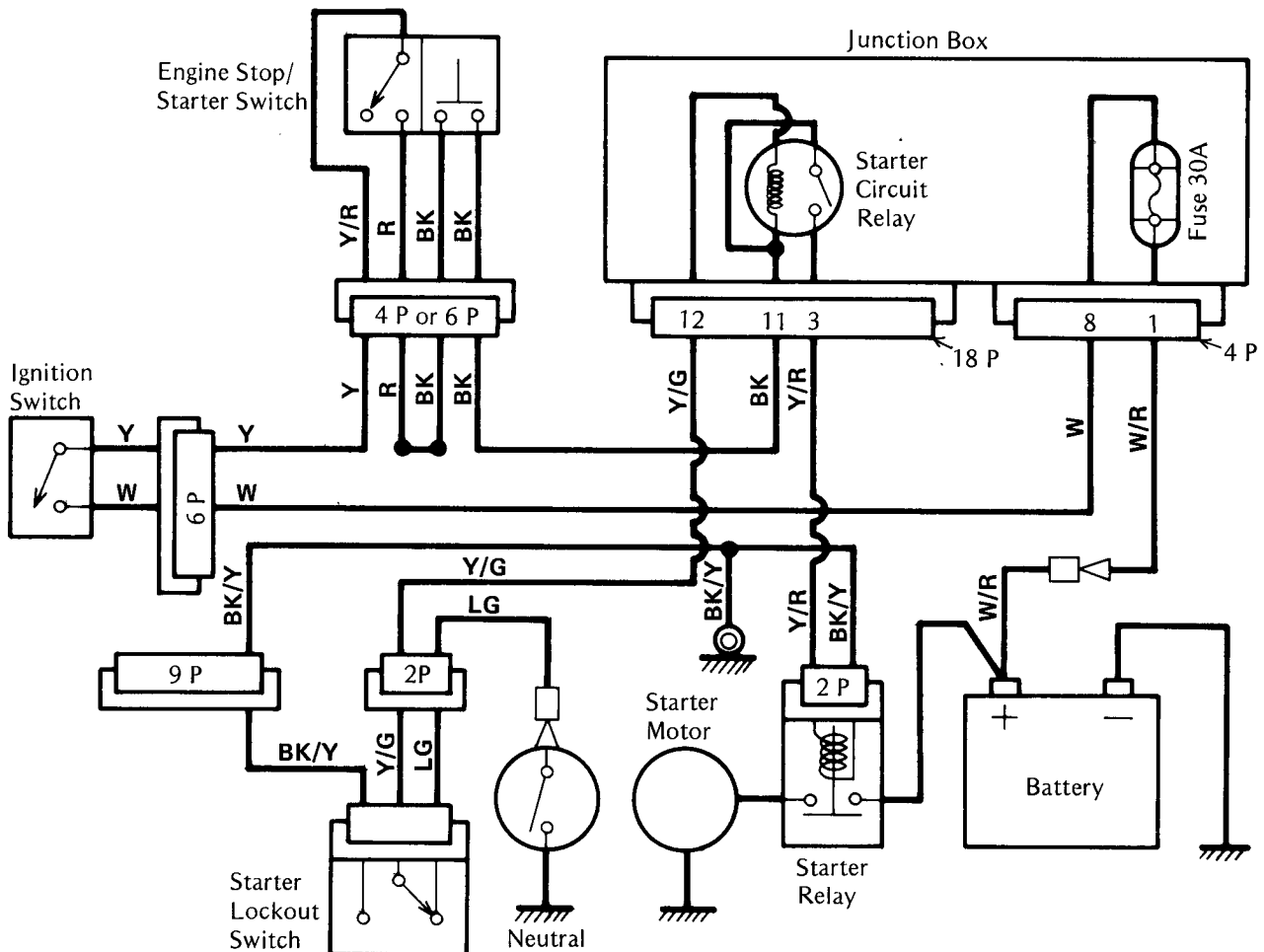

376 SUPPLEMENT – 1983 MODEL

Junction Box Inspection

Refer to p. 370 – 371.

Fuse Inspection

Refer to p. 369.

Starter Circuit Relay Inspection

Refer to p. 369 – 370.

Ignition Switch Inspection

Refer to p. 374.

Engine Stop/Starter Switch Inspection

Refer to p. 374.

Starter Lockout Switch Inspection

Refer to p. 374.

Neutral Switch Inspection

Refer to p. 374.

Starter Relay Inspection

Refer to p. 233.

Starter Motor Inspection

Refer to p. 234 – 236.

Headlight System (ZX750A)

The US and Canadian models of the ZX750A contain a relay in the headlight circuit. In these models, the headlight does not go on when the ignition switch is first turned on, but the headlight goes on once the engine is cranked, and stays on until the ignition switch is turned off. But the headlight goes out whenever the engine stop/starter switch is pushed to restart the engine after engine stalling.

“NOTE”

○The following inspection of the headlight is explained on the assumption that the charging system and electric

Checking Power Supply to Reserve Lighting Device

●Using a multimeter, check the voltage of the power supply wires.

Power Supply Test

Switch Position:	
Ignition switch	ON
Meter Connections:	
Meter range	25 V DC
Wire location	Reserve lighting device connector (connected)
Meter (+) →	Blue wire
Meter (–) →	Black/yellow wire
Meter Reading:	OV when engine stop/starter switch is pushed Battery voltage when engine stop/starter switch is released

★If the meter shows the specified voltage, inspect the reserve lighting circuit.

- Bulbs (headlight, indicator lights)
- Dimmer switch
- Reserve lighting device
- Wires and connectors

★If the meter does not show the specified voltage, inspect the headlight relay circuit.

- Junction box
- Fuses (main, head)
- Relays (main, headlight)
- Diode assembly
- Ignition switch
- Wires and connectors

Dimmer Switch Inspection

Refer to p. 241 – 242.

Reserve Lighting Device Inspection

Refer to p. 242.

Junction Box Inspection

Refer to p. 370 – 371.

Fuse Inspection

Refer to p. 369.

Relay Inspection

Refer to p. 369 – 370.

Diode Inspection

Refer to p. 369.

Ignition Switch Inspection

N140

Headlight Circuit
2127

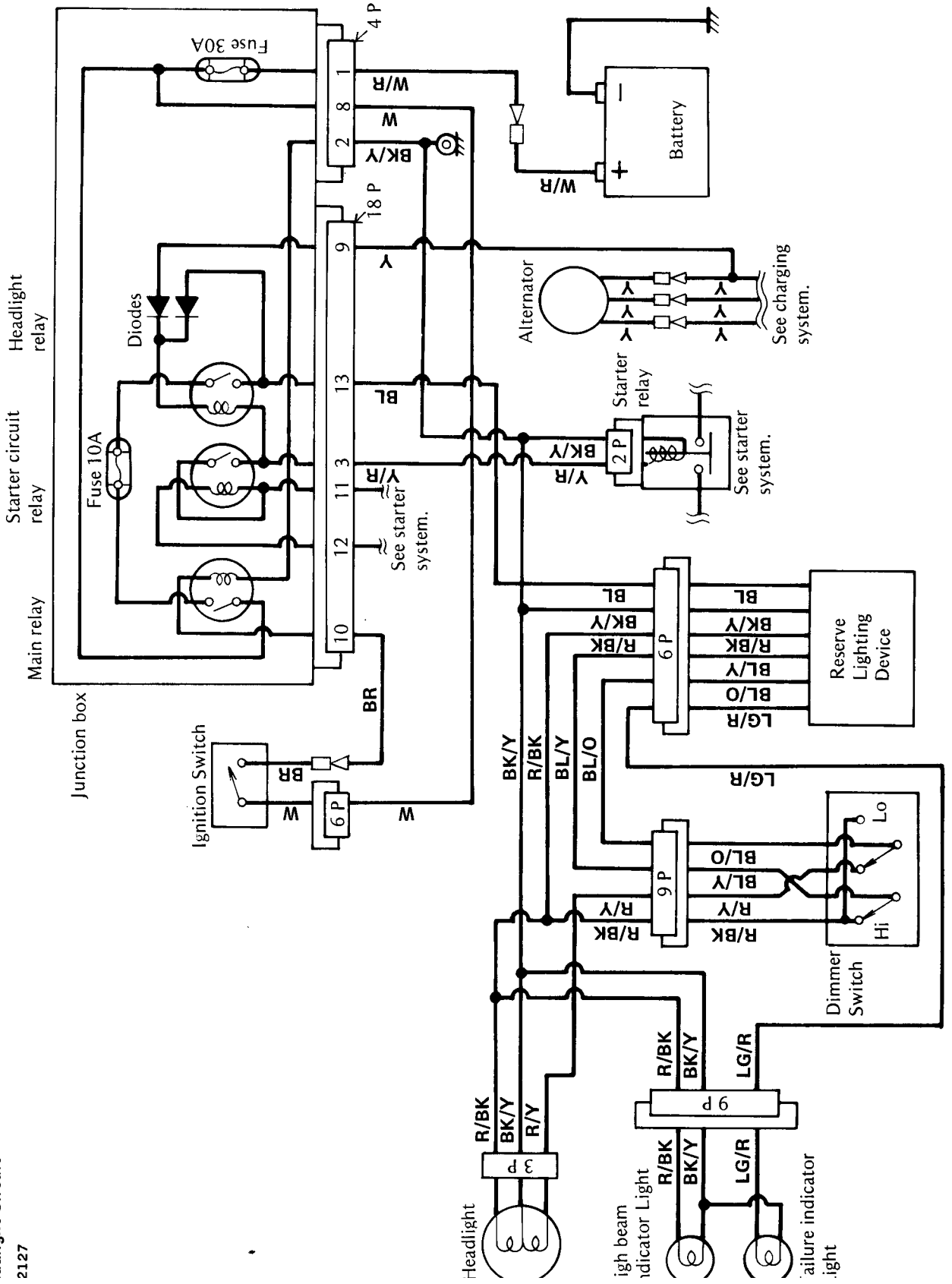

378 SUPPLEMENT – 1983 MODEL

Tachometer (KZ/Z750L)

The tachometer for the 1983 KZ/Z750L is electrically operated but has no voltmeter drive circuit. Refer to p. 319 – 322 to troubleshoot the 1983 KZ/Z750L's tachometer, noting the following.

- It is not necessary to perform the "Voltmeter Test" and "Test No. 4 Switch-Over Switch Test" in the Tachometer Test.

Tachometer Circuit

582128

(N141)

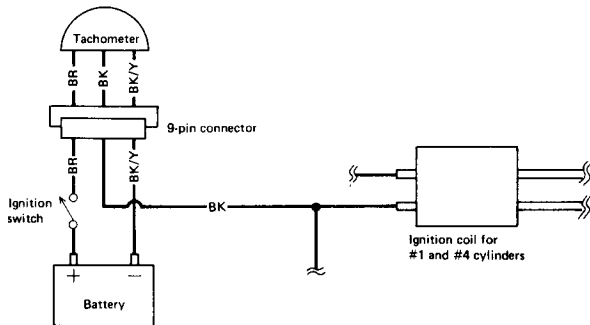

Fuel Gauge (KZ/Z750L)

The fuel gauge is electrically operated through a sensor in the fuel tank. A float in the tank rides up and down with the level of the fuel, changing the internal resistance of the sensor and in this way changing the amount of current flowing through the gauge. The gauge is of the bimetal type with a voltage regulator built into it for over voltage protection.

Troubleshooting:

Circuit Inspection

- Disconnect the fuel level sensor 2-pin connector, and turn on the ignition switch. At this time, the gauge should read E.
- Short together the black/yellow and white/yellow wires of the female connector using an auxiliary test wire.

★ If the above E and F readings are correct, the fuel level sensor is bad. If these readings are not obtained, the trouble is with the gauge and/or wiring.

- Using a voltmeter, check the voltage of the power supply wires for the gauge.

Circuit Inspection

Ignition Switch Position:	ON
Meter Connections:	
Wire location	Fuel gauge 4-pin connector (connected)
Meter range	25 V DC
Meter (+) →	Brown wire
Meter (-) →	Black/yellow wire
Meter Reading:	Battery voltage

★ If the meter does not show the specified voltage, inspect the power supply wires for damage.

Fuel Level Sensor Inspection

Refer to the information for the fuel level sensor test on p. 327.

Fuel Gauge Circuit

582129

(N142)

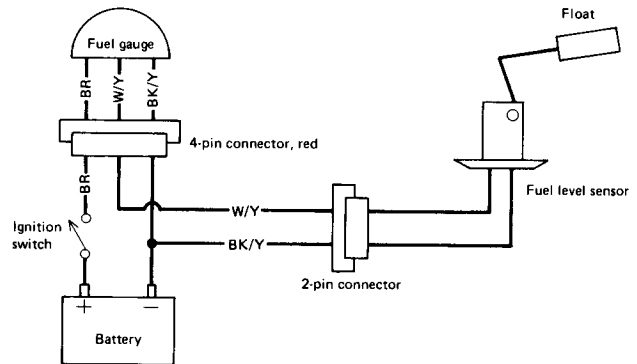

LCD Fuel Gauge and Warner Unit (ZX750A)

Outline:

Gauge and Warning System

582130

N143

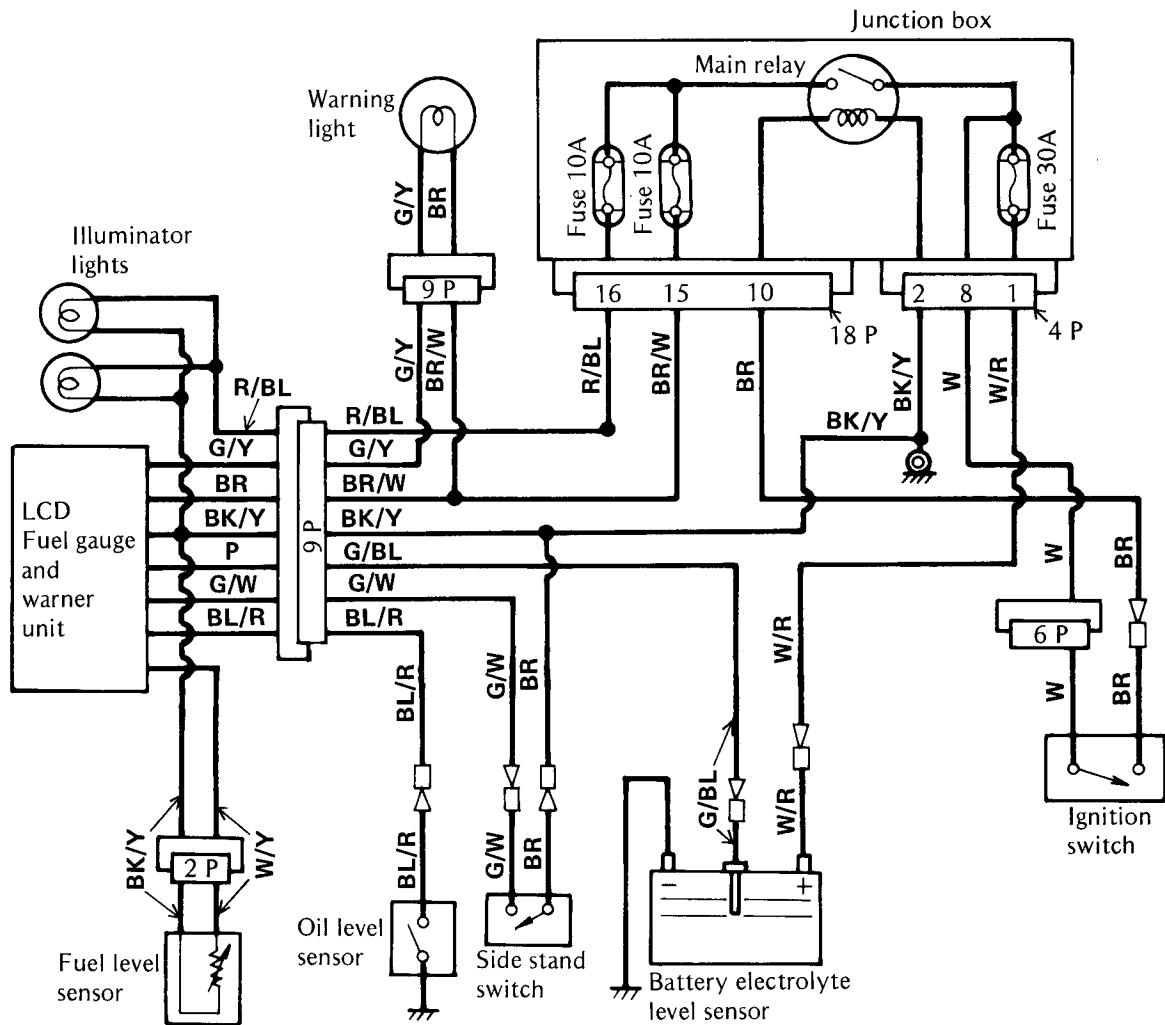

1. The STAND, ENG. SW. warner is changed to the STAND warner, and the ENG. SW. warner is deleted.
 ○STAND (Side Stand Warning): This red LCD warner consists of two segments, upper and lower halves. When the side stand is down, this warner warns the rider by flashing.
2. The warning light is separated from the LCD unit and built in the indicator panel.
 ○Warning Light: This red warning light flashes when any one of the LCD warners flashes.

Test No. 2-Power Supply Test

Voltmeter Connections:	
Lead location	Female gauge and warner unit connector (disconnected)
Meter range	25 V DC
Meter (+) →	Brown/white wire
Meter (-) →	Black/yellow wire
Meter Reading:	
When ignition switch is off	0 V
When ignition switch is on	Battery voltage

Gauge and Warning System Troubleshooting:

Refer to p. 324 – 327, noting the following.

Test No. 1 – Quick Initial Check

★If the meter does not show the specified voltage inspect the brown/white wire, black/yellow wire, and connectors for damage. Repair or replace the damaged

380 SUPPLEMENT – 1983 MODEL

★If the gauge and warner unit is powered by the battery but does not work properly, continue with the “*Test No. 3-Gauge and Warner Unit Test.*”

Test No. 3-Gauge and Warner Unit Test

- Prepare seven auxiliary wires, two to supply battery power to the unit, four to simulate the sensors, and one to connect to the warning light.
- Remove the gauge and warner unit from the fuel tank.
- Connect one wire between the green/yellow wires in the male unit connector and female main harness connector.
- Connect the four sensor simulating wires to the terminals in the unit connectors.

Sensor Simulating Wire Connections

Circuit	Connections
Side Stand Warner	○Green/white lead → Battery (-)
Oil Level Warner	○Blue/red lead → Battery (-)
Battery Electrolyte Level Warner	○Pink lead → Battery (+)
Fuel Gauge and Warner	○White/yellow lead → Battery (-)

Gauge and Warner Unit Test

582131

N144

(a) All sensor simulating wires are connected.

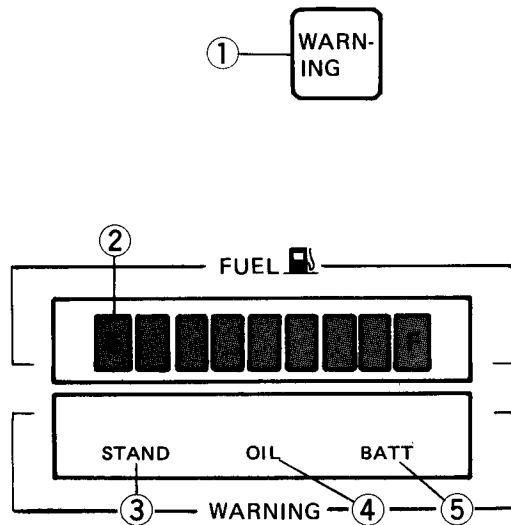

1. Warning Light: Unlits.
2. Fuel Gauge: Nine segments appear.
3. Side Stand Warner: Does not appear.
4. Oil Level Warner: Does not appear.
5. Battery Electrolyte Level Warner: Does not appear.

- Using the wires to supply battery power to the unit, connect the brown terminal in the connector with the battery positive (+) terminal and connect the black/yellow terminal in the connector with the battery negative (-) terminal.

CAUTION

○Take care not to short the wires to the chassis ground.

★When the unit is connected to the battery, the self-checking procedure should start. After the procedure is completed, the gauge and warner display should be as shown in the figure (a). If the self-checking procedure did not start, or if there is any fault on the display; replace the gauge and warner unit.

●Disconnect one of the sensor simulating wires from the connector.

★If both the LCD warner and the red warning light flash as shown in the figure (b), the unit works properly. Proceed to the “*Test No. 4 Wiring and Connector Test.*” If any of them does not flash, or if any of them stays on without flashing, replace the gauge and warner unit.

(b) Sensor simulating wires are disconnected.

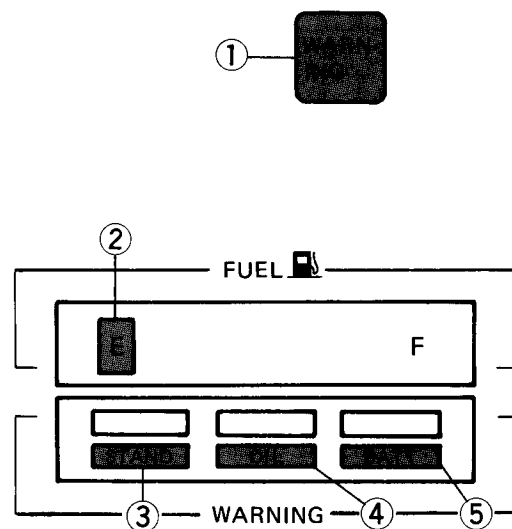

1. Warning Light: Flashes when any one of simulating wires is disconnected.
- *2. Fuel Warner: Flashes when white/yellow wire is disconnected.
3. Side Stand Warner: Flashes when green/white wire is disconnected.
4. Oil Level Warner: Flashes when blue/red wire is disconnected.
5. Battery Electrolyte Level Warner: Flashes when pink wire is disconnected.

*The time delay circuit is provided in the fuel gauge circuit to stabilize the gauge display. It takes 3 to 12 seconds for

Test No. 4-Wiring and Connector Test

- Set the motorcycle on the center stand.
- Remove the fuel tank.
- Connect the multimeter to the wire in the disconnected female connector (main wiring harness side connector) as indicated in the table and read the meter. When checking the wiring for the fuel gauge and low fuel warner, disconnect the fuel level sensor connector.
- ★If the multimeter does not read as shown in the table, first inspect the related wire(s) and connector(s), then repair or replace the damaged part(s). If the wire(s) and connector(s) prove good, proceed to the "Test No. 5-Sensor Test."

Test No. 5-Sensor Test

- (a) **Side Stand Switch:**
Refer to p. 326.
- (b) **Oil Level Sensor:**
Refer to p. 326.
- (c) **Electrolyte Level Sensor:**
Refer to p. 327 and p. 364.
- (d) **Fuel Level Sensor:**
Refer to p. 327.

- Lubricate the points listed below with indicated lubricant.

"NOTE"

○Whenever the vehicle has been operated under wet or rainy conditions, or especially after using a high-pressure spray water, perform the general lubrication.

Pivot Points: Lubricate with Motor Oil

- Center Stand
- Clutch lever
- Front brake lever
- Rear brake pedal
- Rear brake rod joint
- Side stand

Cables: Lubricate with Motor Oil

- Clutch cable
- Throttle cable

Cable Lubrication

282111

N145

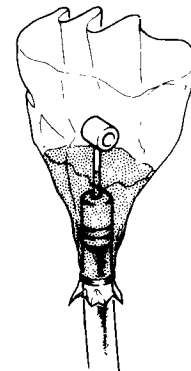

.....
General Lubrication
.....

Lubrication

- Before lubricating each part, clean off any rusty spots with rust remover and wipe off any grease, oil, dirt, or grime.

Wiring and Connector Test

Wire	Meter Range	Meter Connections	Meter Reading (Criteria)
Side stand warner	x 1 Ω	○One meter lead → Green/white wire ○Other meter lead → Black/yellow wire	○0 Ω when side stand is up. ○∞ Ω when side stand is down.
Oil level warner	x 10 Ω	○One meter lead → Blue/red wire ○Other meter lead → Black/yellow wire	○Less than 0.5 Ω when engine oil level is higher than "lower level line" next to the oil level gauge. ○∞ Ω when engine oil level is much lower than the "lower level line."
Battery electrolyte level warner	10 V DC	○Meter (+) → Pink wire ○Meter (-) → Black/yellow wire	○More than 6 V when electrolyte level is higher than "lower level line." ○0 V when electrolyte level is lower than "lower level line."
Fuel gauge and low fuel warner	x 10 Ω	○One meter lead → White/yellow wire ○Other meter lead → Black/yellow wire	○1 – 117 Ω

382 SUPPLEMENT – 1983 MODEL

Points and Portions: Lubricate with Grease

Speedometer inner cable*
Tachometer inner cable* (KZ750H)
Throttle inner cable upper end

*Grease the lower part of the inner cable sparingly.

.....
Bolts

Nuts

Fasteners
.....

Tightness Inspection

- Check the tightness of the bolts and nuts listed here. Also, check to see that each cotter pin or safety clip is in place and in good condition.

"NOTE"

○ *For the engine fasteners, check the tightness of them when the engine is cold (at room temperature).*

★ If there are loose fasteners, retorque them to the specified torque following the specified tightening sequence. (See "Torque and Locking Agent" section. For each fastener, first loosen it by ½ turn, then tighten it.

★ If cotter pins or safety clips are damaged, replace them with new ones.

Bolts, Nuts, and Fasteners to be checked

Wheels:

- Front axle nut
- Front axle clamp bolt or nuts
- Rear axle nut
- Rear axle nut cotter pin

Brakes:

- Front master cylinder clamp bolts
- Rear master cylinder mounting bolts
- Caliper mounting bolts
- Brake pedal bolt
- Brake rod clevis pin cotter pin
- Torque link nuts

Suspensions:

- Front fork clamp bolts and nuts
- Swing arm pivot shaft nut
- Rear shock absorber nuts
- Uni-trak links nuts (ZX750A)

Steering:

- Handlebar clamp bolts
- Handlebar holder bolts (ZX750A)
- Stem head bolt
- Stem head clamp bolt and nut (KZ750H, KZ/Z750L)

Engine:

- Muffler mounting bolts (and nuts)
- Exhaust pipe holder nuts
- Muffler connecting clamp bolts
- Engine mounting bolts and nuts
- Engine mounting bracket bolts and nuts
- Shift pedal bolt(s)
- Cylinder head nuts

Others:

- Clutch lever holder bolt
- Side stand pivot bolt (and nut)
- Center stand cotter pin or bolts and nuts
- Footpeg mounting bolts (and nuts)
- Footpeg cotter pins or circlips

(): If applicable

Appendix

.....
Special Tool (ZX750A)
.....

Refer to p. 258 – 262, p. 279 – 280, and p. 328, noting the following.

- Use driver 57001-1104 to press-fit the oil seal and dust seal into the fork outer tube.



N146

Driver: 57001-1104

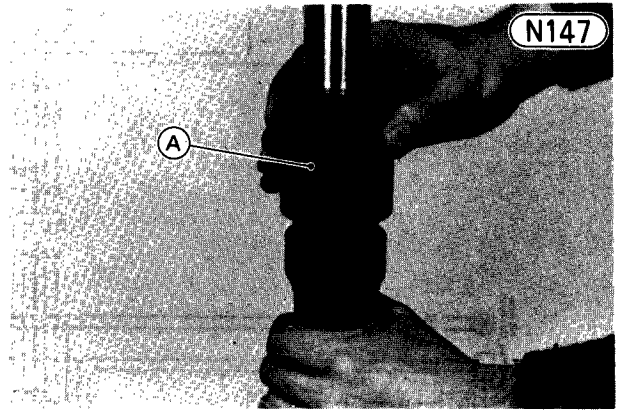

A. Driver: 57001-1104

Supplement – 1984 Model

NOTE

- The service informations for the 1984 KZ700A are newly included in this section. Unless otherwise noted, refer to the informations for the following 1983 models.
KZ/Z750-L3 for KZ700-A1
- Unless otherwise noted, refer to the informations for the following 1983 models to service the 1984 models.
KZ/Z750-L3 for KZ/Z750-L4
ZX750-A1 for ZX750-A2
- See the service data (p. 399) when servicing the 1984 models.

Table of Contents

Model Identification	390
Specifications	392
Periodic Maintenance Chart	389
Service Data	399
Torque and Locking Agent	400
Wiring Diagram	404
Evaporative Emission Control Sytem (US California Vehicle only)	408
Handlebars (ZX750A)	409
Ignition System (KZ700A & KZ/Z750L)	409
Electric Starter System	409
Spark Plugs	410

390 SUPPLEMENT – 1984 MODEL

.....
Model Identification
.....

KZ700-A1

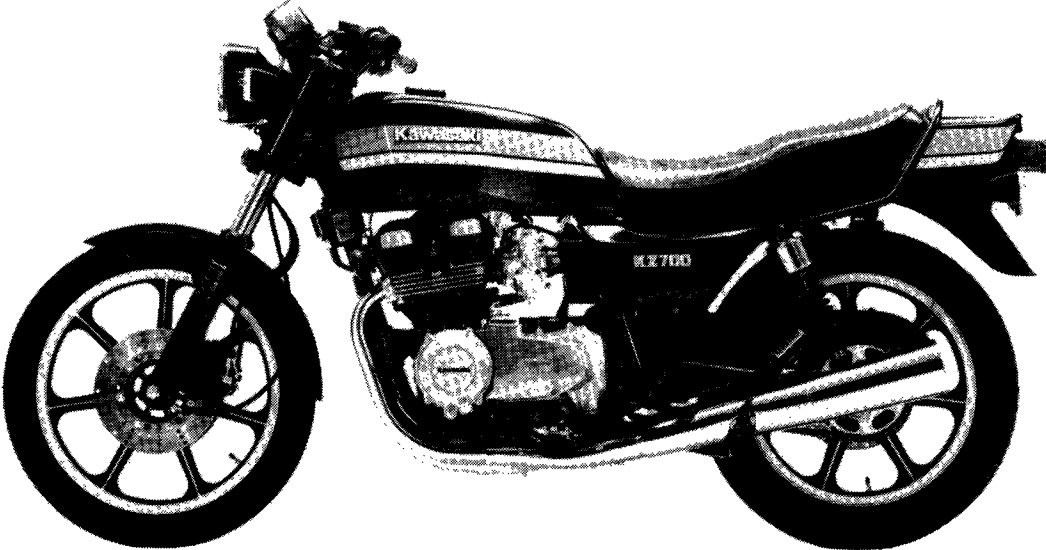

KZ/Z750-L4

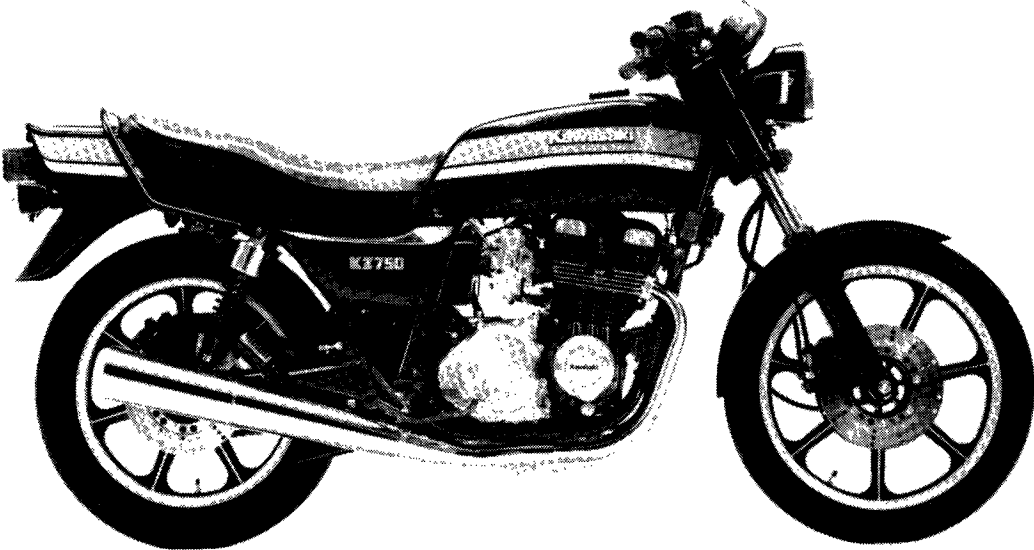

ZX750-A2

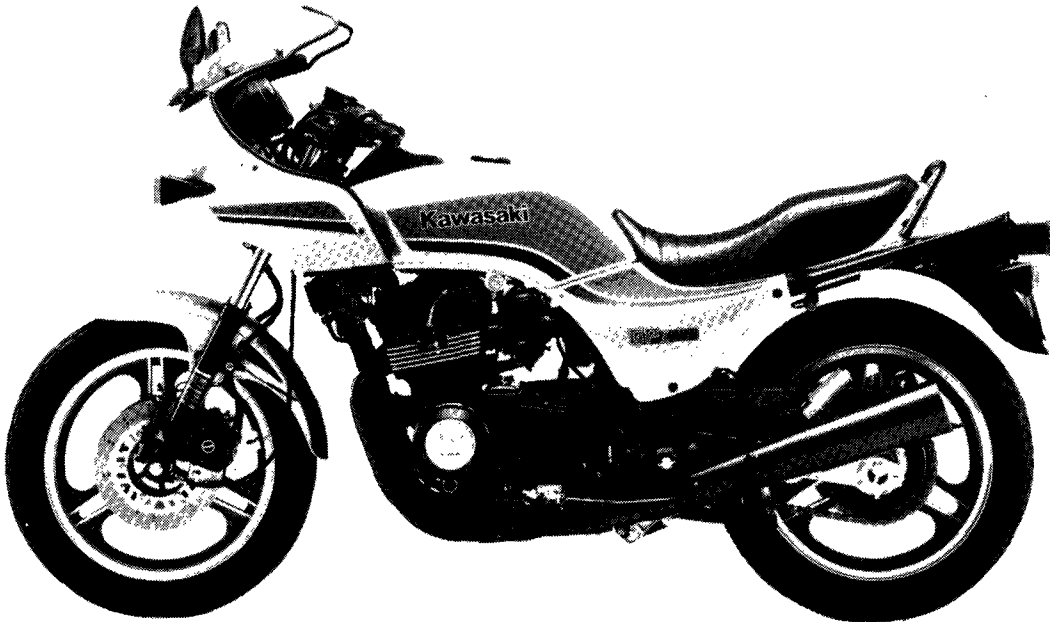

392 SUPPLEMENT — 1984 MODEL

.....
Specifications (KZ700A and KZ/Z750L)

Items	KZ700-A1	KZ/Z750-L4
Dimensions:		
Overall length	2,170 mm	2,215 mm © 2,170 mm
Overall width	770 mm	*
Overall height	1,130 mm	1,135 mm © 1,130 mm
Wheelbase	1,460 mm	*
Road clearance	140 mm	*
Seat height	800 mm	*
Dry weight	2,120 N (216 kg) (Cal) 2,125 N (216.5 kg)	2,110 N (215 kg) © 2,120 N (216 kg)
Curb weight:	Front 1,090 N (111 kg) (Cal) 1,095 N (111.5 kg)	*
	Rear 1,210 N (123 kg)	*
Fuel tank capacity	21.7 L	*
Performance:		
Climbing ability	30°	*
Braking distance	12.5 m from 50 km/h	*
Minimum turning radius	2.5 m	*
Engine:		
Type	4-stroke, DOHC, 4-cylinder	*
Cooling system	Air cooled	*
Bore and stroke	64.0 x 54.0 mm	66.0 x 54.0 mm
Displacement	694 mL	738 mL
Compression ratio	9.7	9.5
Maximum horsepower	56.6 kW (77 PS) @9,500 r/min (rpm)	58.8 kW (80 PS) @9,000 r/min (rpm)
Maximum torque	62.8 N-m (6.4 kg-m, 46.3 ft-lb) @7,500 r/min (rpm)	65.7 N-m (6.7 kg-m, 48.5 ft-lb) @7,500 r/min (rpm)
Carburetion system	Carburetors, Mikuni BS34 x 4	Carburetors, Mikuni BS34 x 4
Starting system	Electric starter	*
Ignition system	Battery and coil (transistorized)	*
Timing advance	Electronically advanced	*
Ignition timing	From 10° BTDC @1,050 r/min (rpm) to 35° BTDC @3,400 r/min (rpm) (Cal) From 10° BTDC @1,200 r/min (rpm) to 35° BTDC @3,400 r/min (rpm)	From 10° BTDC @1,050 r/min (rpm) to 35° BTDC @3,800 r/min (rpm)

SUPPLEMENT — 1984 MODEL 39

Items	KZ700-A1	KZ/Z750-L4
Spark plug	NGK B8ES or ND W24ES-U	NGK BR8ES or ND W24ESR-U
Cylinder numbering method	Left to right, 1-2-3-4	*
Firing order	1-2-4-3	*
Valve timing:		
Inlet		
Open	30° BTDC	*
Close	60° ABDC	*
Duration	270°	*
Exhaust		
Open	60° BBDC	*
Close	30° ATDC	*
Duration	270°	*
Lubrication system	Forced lubrication (wet sump with cooler)	*
Engine oil:		
Grade	SE class	*
Viscosity	SAE 10W40, 10W50, 20W40, or 20W50	*
Capacity	3.5 L	*
Drain Train:		
Primary reduction system:		
Type	Gear and chain	*
Reduction ratio	2.550 (27/23 x 63/29)	*
Clutch type	Wet multi disc	*
Transmission:		
Type	5-speed, constant mesh, return shift	*
Gear ratio:		
1st	2.333 (35/15)	*
2nd	1.631 (31/19)	*
3rd	1.272 (28/22)	*
4th	1.040 (26/25)	*
5th	0.875 (21/24)	*
Final drive system:		
Type	Chain drive	*
Reduction ratio	2.538 (33/13)	*
Overall drive ratio	5.664 @Top gear	*
Frame:		
Type	Tubular, double cradle	*
Caster (rake angle)	27°	*
Trail	107 mm	*

394 SUPPLEMENT — 1984 MODEL

Items	KZ700-A1	KZ/Z750-L4
Front tire:		
Type	Tubeless	*
Size	100/90-19 57H	*
Rear tire:		
Type	Tubeless	*
Size	120/90-18 65H	*
Front suspension:		
Type	Telescopic fork (pneumatic)	*
Wheel travel	150 mm	*
Rear suspension:		
Type	Swing arm	*
Wheel travel	111 mm	*
Brake type:		
Front	Dual disc	*
Rear	Single Disc	*
Electrical Equipment:		
Battery	12 V 12 AH	*
Headlight:		
Type	Semi-sealed beam	*
Bulb	12 V 60/55 W (quartz-halogen)	*
Tail/brake light	12 V 8/27 W x 2	12 V 5/21 W x 2 © 12 V 8/27 W x 2
Alternator:		
Type	Three-phase AC	*
Rated output	17 A @8,000 r/min (rpm), 14 V	*
Voltage regulator:		
Type	Short-circuit	*

Specifications subject to change without notice, and may not apply to every country.

© : Canadian Model

© : Californian Model

.....
Specifications (ZX750A)

Items	ZX750-A2
Dimensions: Overall length Overall width Overall height Wheelbase Road clearance Seat height Dry weight Curb weight: Front Rear Fuel tank capacity	2,220 mm (C) (Cal) (S) (U) 2,190 mm 740 mm (C) (Cal) (F) (U) 720 mm 1,260 mm 1,490 mm 150 mm 800 mm 2,160 N (220 kg) (C) (U) 2,150 N (219 kg) (Cal) 2,150 N (219.5 kg) (S) 2,170 N (221 kg) 1,140 N (116 kg) (C) (U) 1,130 N (115 kg) (Cal) 1,130 N (115.5 kg) 1,200 N (122 kg) (S) 1,210 N (123 kg) 19.0 L
Performance: Climbing ability Braking distance Minimum turning radius	30° 12.5 m from 50 km/h 2.7 m
Engine: Type Cooling system Bore and stroke Displacement Compression ratio Maximum horsepower Maximum torque Carburetion system Starting system Ignition system Timing advance Ignition timing	4-stroke, DOHC, 4-cylinder Air cooled 66.0 x 54.0 mm 738 mL 9.5 63.3 kW (86 PS) @9,500 r/min (rpm) (Cal) (U) 62.5 kW (85 PS) @9,500 r/min (rpm) (Sw) (W) 64.0 kW (87 PS) @9,500 r/min (rpm) 67.7 N-m (6.9 kg-m, 50.0 ft-lb) @7,500 r/min (rpm) (Sw) (W) 68.6 N-m (7.0 kg-m, 51 ft-lb) @7,500 r/min (rpm) Carburetors, Mikuni BS34 x 4 Electric starter Battery and coil (transistorized) Electronically advanced From 10° BTDC @1,050 r/min (rpm) to 40° BTDC @3,600 r/min (rpm) (Cal) From 10° BTDC @1,200 r/min (rpm) to 40° BTDC @3,600 r/min (rpm)

396 SUPPLEMENT – 1984 MODEL

Items	ZX750-A2
<p>Spark plug</p> <p>Cylinder numbering method</p> <p>Firing order</p> <p>Valve timing: Inlet Open</p> <p> Close</p> <p> Duration</p> <p> Exhaust Open</p> <p> Close</p> <p> Duration</p> <p>Lubrication sytem</p> <p>Engine oil:</p> <p> Grade</p> <p> Viscosity</p> <p> Capacity</p>	<p>NGK BR9ES or ND W27ESR-U (A) (Ca) (I) (N) (S) (U) NGK B9ES or ND W27ES-U</p> <p>Left to right, 1-2-3-4</p> <p>1-2-4-3</p> <p>38° BTDC</p> <p>68° ABDC</p> <p>286°</p> <p>68° BBDC</p> <p>38° ATDC</p> <p>286°</p> <p>Forced lubrication (wet sump with cooler)</p> <p>SE class</p> <p>SAE 10W40, 10W50, 20W40, or 20W50</p> <p>3.5 L</p>
<p>Drive Train:</p> <p>Primary reduction sytem:</p> <p> Type</p> <p> Reduction ratio</p> <p>Clutch type</p> <p>Transmission:</p> <p> Type</p> <p> Gear ratios: 1st</p> <p> 2nd</p> <p> 3rd</p> <p> 4th</p> <p> 5th</p> <p>Final drive system:</p> <p> Type</p> <p> Reduction ratio</p> <p> Overall drive ratio</p>	<p>Gear and chain</p> <p>2.550 (27/23 x 63/29)</p> <p>Wet multi disc</p> <p>5-speed, constant mesh, return shift</p> <p>2.333 (35/15)</p> <p>1.631 (31/19)</p> <p>1.272 (28/22)</p> <p>1.040 (26/25)</p> <p>0.875 (21/24)</p> <p>Chain drive</p> <p>2.533 (38/15)</p> <p>5.652 @Top gear</p>
<p>Frame:</p> <p> Type</p> <p> Caster (rake angle)</p> <p> Trail</p>	<p>Tubular, double cradle</p> <p>26.5°</p> <p>103 mm</p>

Items	ZX750-A2
<p>Front tire:</p> <p> Type</p> <p> Size</p> <p>Rear tire:</p> <p> Type</p> <p> Size</p> <p>Front suspension:</p> <p> Type</p> <p> Wheel travel</p> <p>Rear suspension:</p> <p> Type</p> <p> Wheel travel</p> <p>Brake type:</p> <p> Front</p> <p> Rear</p>	<p>Tubeless</p> <p>110/90V 18 © (Ca) U 110/90-18 61H</p> <p>Tubeless</p> <p>130/80V 18 © (Ca) U 130/80-18 66 H</p> <p>Telescopic fork (pneumatic)</p> <p>150 mm</p> <p>Swing arm (uni-trak)</p> <p>130 mm</p> <p>Dual disc</p> <p>Single disc</p>
<p>Electrical Equipment:</p> <p>Battery</p> <p>Headlight:</p> <p> Type</p> <p> Bulb</p> <p>Tail/brake light</p> <p>Alternator:</p> <p> Type</p> <p> Rated output</p> <p>Voltage regulator:</p> <p> Type</p>	<p>12 V 14 AH</p> <p>Semi-sealed beam</p> <p>12 V 60/55 W (quarts-halogen)</p> <p>12 V 5/21 W x 2 © (Ca) S U 12 V 8/27 W x 2</p> <p>Three-phase AC</p> <p>17 A @8,000 r/min (rpm), 14 V</p> <p>Short-circuit</p>

Specifications subject to change without notice, and may not apply to every country.

(A) : Australian Model
 (F) : French Model
 (S) : South African Model
 (W) : West German Model

(C) : Canadian Model
 (I) : Italian Model
 (Sw) : Swedish Model

(Ca) : Californian Model
 (N) : Norwegian Model
 (U) : U.S. Model

398 SUPPLEMENT – 1984 MODEL

Periodic Maintenance Chart

The scheduled maintenance must be done in accordance with this chart to keep the motorcycle in good running condition. The initial maintenance is vitally important and must not be neglected.

OPERATION	FREQUENCY	Which ever comes first		*ODOMETER READING						See Page
		Every	800 km	5,000 km	10,000 km	15,000 km	20,000 km	25,000 km	30,000 km	
Spark plug – clean		•	•	•	•	•	•	•	•	12
Spark plug – check †		•	•	•	•	•	•	•	•	12
Valve clearance – check †		•	•	•	•	•	•	•	•	12
Air suction valve – check † (US model)			•	•	•	•	•	•	•	166
Air cleaner element – clean			•							312,366
Air cleaner element – replace	5 cleanings			•		•			•	148,312
Throttle grip play – check †		•	•	•	•	•	•	•	•	291
Idle speed – check †		•	•	•	•	•	•	•	•	15
Engine vacuum synchronization – check †		•	•	•	•	•	•	•	•	15
Fuel system – check †				•		•			•	19,291
Cylinder head bolt tightness – check †		•		•		•			•	35
Cylinder head nut tightness – check †		•		•		•			•	35
Evaporative emission control system (Cal) – check †		•	•	•	•	•	•	•	•	---
Engine oil – change	year	•	•	•	•	•	•	•	•	18
Oil filter – replace		•		•		•			•	18
Fuel hose – replace	4 years									—
Clutch – adjust		•	•	•	•	•	•	•	•	17,291,346
Drive chain wear – check †			•	•	•	•	•	•	•	198
Drive chain – lurbriate	300 km									198
Drive chain slack – check †	800 km									23, 347
Brake lining wear – check †			•	•	•	•	•	•	•	203
Brake fluid level – check †	month	•	•	•	•	•	•	•	•	207
Brake fluid – change	year			•		•			•	206
Brake hose – replace (Not on ZX750A)	4 years									208
Brake hose and pipe – replace (ZX750A)	4 years									208,367
Anti-dive brake plunger assembly – replace (ZX750A)	2 years									367
Master cylinder cup and dust seal – replace	2 years									201
Caliper piston seal and dust seal – replace	2 years									204
Brake light switch – check †		•	•	•	•	•	•	•	•	25
Steering – check †		•	•	•	•	•	•	•	•	26,293
Steering stem bearing – lubricate	2 years									---
Front fork oil – change				•		•			•	214,318,364
Tire wear – check †			•	•	•	•	•	•	•	193
Wheel bearing – lubricate	2 years					•				197
Speedometer gear – lubricate	2 years					•				197
Swing arm pivot – lubricate (Not on ZX750A)				•		•			•	276
Swing arm pivot, uni-trak linkage – lubricate (ZX750A)				•		•			•	368
Battery electrolyte level – check † (Not on ZX750A)	month	•	•	•	•	•	•	•	•	218
General lubrication – perform			•	•	•	•	•	•	•	381
Nut, bolt, and fastener tightness – check †		•		•		•			•	382

.....
Service Data

Refer to pp.385 through 365, noting the following.

Engine:

Item	Standard	Service Limit	See Page												
Carburetors: (KZ700-A)															
Make, Type	Mikuni, BS34	---													
Main Jet	#105	---													
Needle jet	Y-9	---													
Jet needle:	4BE04	---													
Jet needle clip position:	Non-adjustable	---													
Pilot jet	37.5	---													
Pilot screw:	Non-adjustable	---													
Service fuel level	3 ± 1 mm	---	156,317												
Float height	18.6 ± 2 mm	---	317,366												
Cylinder Head Valves: (ZX750-A)															
Valve clearance Inlet	0.13 – 0.23 mm	---													
Exhaust	0.13 – 0.23 mm	---	13												
Cylinder Compression: (KZ700-A1)	1,120 – 1,310 kPa (11.4 – 13.4 kg/cm ² , 162 – 191 psi) Ⓞ 1,130 – 1,320 kPa (11.5 – 13.5 kg/cm ² , 164 – 192 psi)	855 – 1,310 kPa (8.7 – 13.4 kg/cm ² , 124 – 191 psi), or 98 kPa (1 kg/cm ² , 14 psi) difference between any two cylinders	169												
Cylinder Block, Pistons: (KZ700-A)															
Cylinder inside diameter	64.005 – 64.017 mm	64.1 mm	169												
Piston diameter	63.966 – 63.951 mm	63.80 mm	170												
Piston ring end gap (top and second):	0.10 – 0.25 mm (installed in standard cylinder bore)	0.55 mm	171												
Connecting rod bearing insert selection:															
		<table border="1" style="margin-left: auto; margin-right: auto;"> <thead> <tr> <th colspan="2">Marking for con-rod big end bore</th> </tr> <tr> <th>○</th> <th>None</th> </tr> </thead> <tbody> <tr> <td style="text-align: center;">Black</td> <td style="text-align: center;">Brown</td> </tr> <tr> <td style="text-align: center;">P/N: 92028-1204</td> <td style="text-align: center;">P/N: 92028-1205</td> </tr> <tr> <td style="text-align: center;">Green</td> <td style="text-align: center;">Black</td> </tr> <tr> <td style="text-align: center;">P/N: 92028-1203</td> <td style="text-align: center;">P/N: 92028-1204</td> </tr> </tbody> </table>		Marking for con-rod big end bore		○	None	Black	Brown	P/N: 92028-1204	P/N: 92028-1205	Green	Black	P/N: 92028-1203	P/N: 92028-1204
Marking for con-rod big end bore															
○	None														
Black	Brown														
P/N: 92028-1204	P/N: 92028-1205														
Green	Black														
P/N: 92028-1203	P/N: 92028-1204														
<table border="1" style="margin-left: auto; margin-right: auto;"> <thead> <tr> <th>Marking for crankpin diameter</th> <th>○</th> </tr> </thead> <tbody> <tr> <td style="text-align: center;">None</td> <td style="text-align: center;">None</td> </tr> </tbody> </table>	Marking for crankpin diameter	○	None	None			174,351								
Marking for crankpin diameter	○														
None	None														

400 SUPPLEMENT — 1984 MODEL

Torque and Locking Agent

The following tables list the tightening torque for the major fasteners requiring use of a non-permanent locking agent or liquid gasket. Unless otherwise noted, refer to p. 350 for the ZX750A.

NOTE

○Marks used in "Remark"

● : Apply a non-permanent locking agent to the threads.

★ : Apply a liquid gasket to the threads or washer.

Engine

Parts	Threads Dia. x Pitch (mm)	Quan- tity	Torque			Remarks	See Page
			kg-m	N-m	ft-lb		
Air suction valve cover bolts	6 x 1.0	(8)	0.80	7.8	69 in-lbs	—	52
Alternator rotor bolt	12 x 1.25	1	13.0	125	94	—	351
Alternator stator Allen bolts	5 x 0.8	3	0.80	7.8	69 in-lbs	●	71
Alternator cover Allen bolts	6 x 1.0	4	0.9	8.8	78 in-lbs	—	—
Breather cover bolt	8 x 1.25	1	0.60	5.9	52 in-lbs	—	65
Camshaft cap bolts	6 x 1.0	16	1.2	12	104 in-lbs	—	55
Camchain tensioner cap	18 x 1.5	1	2.5	25	18	—	275
Camshaft sprocket bolts	6 x 1.0	4	1.5	15	11.0	●	57
Carburetor holder screws	6 x 1.0	8	—	—	—	●	—
Clutch cover Allen bolts	6 x 1.0	10	0.9	8.8	78 in-lbs	—	—
Clutch hub locknut	20 x 1.5	1	13.5	130	98	—	75
Clutch release mounting screws	6 x 1.0	2	—	—	—	●	66
Clutch spring bolts	6 x 1.0	5	0.90	8.8	78 in-lbs	—	76
Connecting rod big end can nuts	8 x 0.75	8	3.7	36	27	—	105
Crankcase bolts							
(upper)	6 x 1.0	13	1.2	12	104 in-lbs	—	96
(lower)	6 x 1.0	7	1.2	12	104 in-lbs	—	94
(lower)	8 x 1.25	10	3.0	29	22	—	93
†Cylinder head							
bolts	8 x 1.25	2	3.0	29	22	—	58
nuts	10 x 1.25	12	4.0	39	29	—	57

SUPPLEMENT — 1984 MODEL 40

Parts	Threads Dia. x Pitch (mm)	Quantity	Torque			Remarks	See Page
			kg-m	N-m	ft-lb		
Engine drain plug	12 x 1.5	1	1.3	13	113 in-lbs	—	19
† Engine mounting bolts	10 x 1.25	6	4.0	39	29	—	306
† Engine mounting bracket bolts	8 x 1.25	6	2.4	24	17.5	—	306
Engine sprocket nut	20 x 1.5	1	10.0	98	72	—	67
Neutral switch	12 x 1.5	1	1.5	15	11.0	—	69
Oil filter mounting bolt	20 x 1.5	1	2.0	20	14.5	—	77
Oil pan bolts	6 x 1.0	15	1.0	9.8	87 in-lbs	—	77
Oil pressure switch	PT ¹ / ₈	1	1.5	15	11.0	—	74
Oil pressure relief valve	12 x 1.25	1	2.0	20	14.5	•	77
Oil tube connecting nuts	16 x 1.4	2	2.2	22	16	—	304
Pickup coil cover Allen bolts	6 x 1.0	2	0.9	8.8	78 in-lbs	—	72
Return spring pin (bolt)	8 x 1.25	1	2.0	20	14.5	•	67
Secondary shaft nut	18 x 1.5	1	59	6.0	43	—	81
Shift drum pin plate screw	6 x 1.0	1	—	—	—	•	101
Spark plugs	14 x 1.25	4	2.8	27	20	—	12
Starter motor clutch Allen bolts	8 x 1.25	3	3.5	34	25	•	82
Studs (cylinder head)	6 x 1.0	8	—	—	—	•	—
(crankcase)	10 x 1.25	12	—	—	—	•	—
Timing rotor mounting bolt	8 x 1.25	1	2.5	25	18.0	—	—

Chassis

Parts	Threads Dia. x Pitch (mm)	Quantity	Torque			Remarks	See Page
			kg-m	N-m	ft-lb		
Front axle nut (KZ700-A & KZ750-L)	15 x 1.5	1	6.5	64	47	—	109
(ZX750-A)	14 x 1.5	1	6.0	59	43	—	109
Front axle clamp nut (KZ700A & KZ750-L)	8 x 1.25	4	1.4	14	10	—	109

402 SUPPLEMENT — 1984 MODEL

Parts	Threads Dia. x Pitch (mm)	Quantity	Torque				See Page
			kg-m	N-m	ft-lb		
† Front fender mounting bolts	8 x 1.25	4	—	—	—	—	—
Front fork air valves	8 x 1.0	2	0.8	7.8	69 in-lbs	•	309
Front fork bottom Allen bolts	10 x 1.25	2	2.3	23	16.5	• ★	141
† Front fork clamp bolts							
(upper)	8 x 1.25	2	2.0	20	14.5	—	139
(lower)	10 x 1.25	2	3.8	37	27	—	139
Front fork drain screws	4 x 0.7	2	—	—	—	★	141
Front fork top plugs	28 x 1.0	2	2.3	23	16.5	—	141
† Handlebar clamp bolts	8 x 1.25	4	1.8	18	13.0	—	137
† Rear axle nut	16 x 1.5	1	12.0	12	87	—	24
† Rear shock absorber mounting							
nuts	12 x 1.25	2	3.0	29	22	—	143
bolts	10 x 1.25	2	3.0	29	22	—	143
Rear sprocket nuts	10 x 1.25	6	4.0	39	29	—	115
† Steering stem head bolt	14 x 1.5	1	4.3	42	31	—	293
† Steering stem head clamp bolt nut	8 x 1.25	1	2.1	21	15	—	27, 139
Steering stem locknut	25 x 1.0	1	0.5	4.9	43 in-lbs	—	293
† Swing arm pivot shaft nut	16 x 1.5	1	10.0	98	72	—	144
Tire air valve nuts	8 x 0.8	2	0.15	1.5	13 in-lbs	—	117
† Torque link bolt nuts	10 x 1.25	2	3.0	29	22	—	24, 145

Brake

Parts	Threads Dia. x Pitch (mm)	Quantity	Torque			Remarks	See Page
			kg-m	N-m	ft-lb		
Bleed valves	7 x 1.0	3	0.80	7.8	69 in-lbs	—	119
Brake hose							
banjo bolts	10 x 1.25	7	2.5	25	18.0	—	120,122, 125,126
clamp screws (built in the							

SUPPLEMENT — 1984 MODEL 40

Parts	Threads Dia. x Pitch (mm)	Quan- tity	Torque			Remarks	See Page
			kg-m	N-m	ft-lb		
Brake lever pivot							
bolt	6 x 1.0	1	0.30	2.9	26 in-lbs	—	124
locknut	6 x 1.0	1	0.60	5.9	52 in-lbs	—	124
Caliper holder shaft bolts	8 x 1.25	6	1.8	18	13.0	—	119
Caliper mounting bolts (front and rear caliper)	10 x 1.25	4	3.3	32	24	—	24,120
Disc mounting Allen bolts	8 x 1.25	21	2.3	23	16.5	—	116
† Front caliper mounting bolts	10 x 1.25	4	4.0	39	29	—	120
† Front master cylinder clamp bolts	6 x 1.0	2	0.90	8.8	78 in-lbs	—	122
† Rear caliper mounting bolt nut (torque link)	10 x 1.25	1	3.0	29	22	—	24

Parts marked with a cross (†) must be retorqued according to the Periodic Maintenance Chart (Pg. 398). One at a time, loosen each bolt or nut ½ turn, then tighten it to the specified torque. Follow the sequence if specified. For engine fasteners, retorque them when the engine is cold (at room temperature).

Evaporative Emission Control System
(US California Vehicle only)

The Evaporative Emission Control System routes fuel vapors from the fuel system into the running engine or stores the vapors in a canister when the engine is stopped. Although no adjustments are required, a thorough visual inspection must be made at the intervals specified by the Periodic Maintenance Chart.

Parts Removal/Installation Notes

WARNING

Gasoline is extremely flammable and can be explosive under certain conditions. Turn the ignition switch OFF. Do not smoke. Make sure the area is well ventilated and free from any source of flame or sparks; this includes any appliance with a pilot light.

CAUTION

If gasoline, solvent, water or any other liquid enters the canister, the canister's vapor absorbing capacity is greatly reduced. If the canister does become contaminated replace it with a new one.

To prevent the gasoline from flowing into the canister or from flowing out of the canister, hold the separator perpendicular to the ground.

Connect the hoses according to the diagram of the system. Make sure they do not get pinched or crimped.

Hose Inspection

- Check that the hoses are securely connected.
- Replace any kinked, deteriorated or damaged hoses.

Evaporative Emission Control System
(ZX750-A)

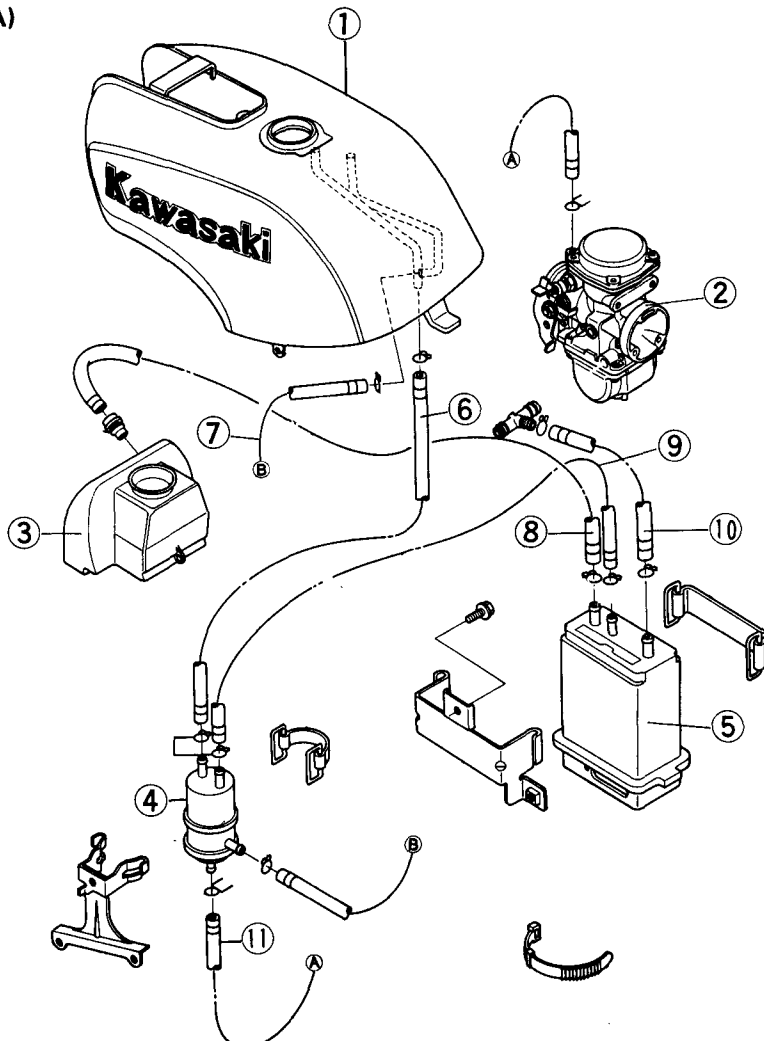

1. Fuel Tank
2. Carburetor
3. Air Cleaner Housing
4. Liquid/Vapor Separator
5. Canister
6. Breather Hose (Blue)
7. Fuel Return Hose (Red)
8. Purge Hose (Green)
9. Breather Hose (Blue)
10. Breather Hose (Yellow)
11. Vacuum Hose

Separator Inspection

- Disconnect the hoses from the liquid/vapor separator, and remove the separator from the motorcycle.
- Visually inspect the separator for cracks and other damage.
- ★ If the separator has any crack or bad damage, replace it with a new one.

Separator Operation Test

WARNING

○ Gasoline is extremely flammable and can be explosive under certain conditions. Turn the ignition switch OFF. Do not smoke. Make sure the area is well ventilated and free from any source of flame or sparks; this includes any appliance with a pilot light.

- Connect the hoses to the separator, and install the separator on the motorcycle.
- Disconnect the breather hose from the separator, and inject about 20 mL of gasoline into the separator through the hose fitting.
- Disconnect the fuel return from the fuel tank.
- Run the open end of the return hose into the container level with the tank top.
- Start the engine, and let it idle.
- ★ If the gasoline in the separator comes out of the hose, the separator works well. If it does not, replace the separator with a new one.

Canister Inspection

- Remove the canister, and disconnect the hoses from the canister.
- Visually inspect the canister for cracks and other damage.
- ★ If the canister has any crack or bad damage, replace it with a new one.

NOTE

○ The canister is designed to work well through the motorcycle's life without any maintenance if it is used under normal conditions.

Handlebars (ZX750A)

- Refer to p. 306 — 307, noting the following.
- The handlebar holder positioning plate must be installed so that the triangular marks on the plate points to the front.
 - Install the handlebars to the handlebar holders so that the mark on the handlebar aligns with the slit on the

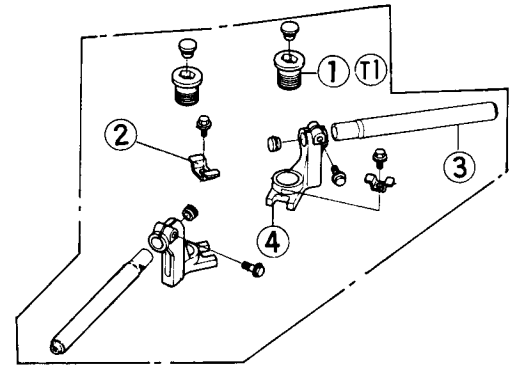

1. Holder Bolt
2. Triangular mark on the handlebar holder positioning plate
3. Mark on the handlebar

*T1: 74 N-m (7.5 kg-m, 54 ft-lb)

Ignition System (KZ700-A & KZ/Z750-L)

The ignition timing is advanced not by a centrifugal advance mechanism but by an electronic circuit in the IC igniter: the electronic advance system.

Dynamic Ignition Timing Inspection

Check the ignition timing with a strobe light for both low and high speed operations.

Checking Engine Speed

Low Speed:	Idle speed
High Speed:	
KZ700A	Above 3,400 r/min (rpm)
KZ/Z750L	Above 3,800 r/min (rpm)

Checking Power Supply to IC Igniter

Refer to p. 373.

Pickup Coil Inspection

Refer to pp. 365 and 373.

Electric Starter System

Refer to p. 375, noting the following. The 1984 model KZ700A and KZ/Z750L have not equipped with

410 SUPPLEMENT – 1984 MODEL

.....
Spark Plugs
.....

Refer to P. 12, noting the following.

KZ700A

	Standard	Low Speed Riding	High Speed Riding
US	NGK B8ES or ND W24ES-U	NGK B7ES or ND W22ES-U	NGK B9ES or ND W27ES-U

ZX750A

	Standard	Low Speed Riding
Europe except below	NGK BR9ES or ND W27ESR-U	NGK BR8ES or ND W24ESR-U
Ⓐ Ⓒal Ⓛ Ⓝ Ⓢ Ⓚ	NGK B9ES or ND W27ES-U	NGK B8ES or ND W24ES-U

Supplement—1985, 1988 Models

Table of Contents

Model Identification	412
Specifications	412

NOTE

*Unless otherwise noted, refer to the informations for the following 1984 model to service the 1985 and 1988 models.
ZX750-A2 for ZX750-A3/A5*

412 SUPPLEMENT — 1985, 1988 MODELS

.....
Model Identification
.....

ZX750-A3/A5

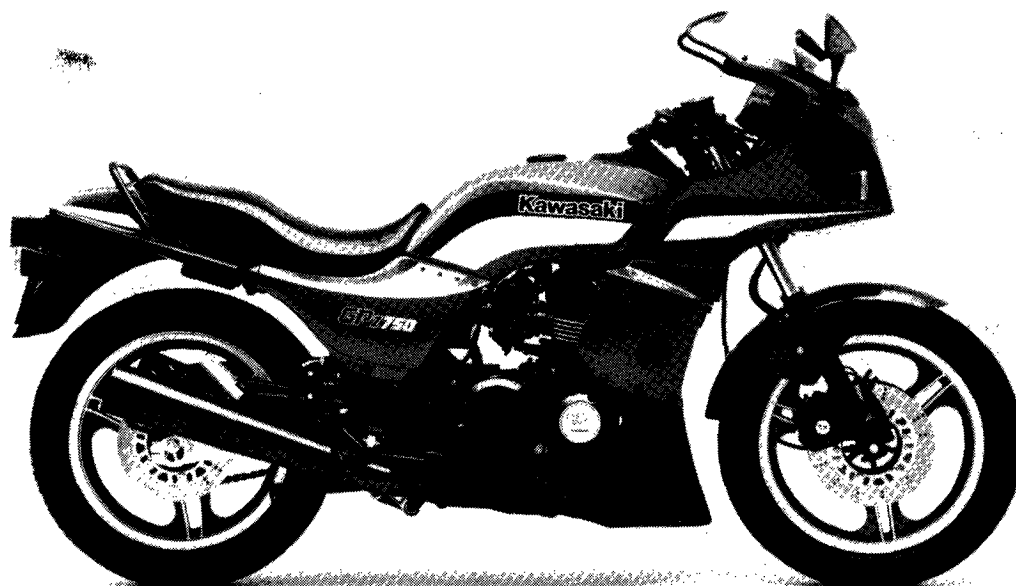

.....
Specifications (ZX750A)
.....

Refer to pp. 395 — 397 for other specifications not specifically mentioned here.

Items	ZX750-A3/A5
Dimensions:	
Road clearance	120 mm
Dry weight	224 kg (Ca) 224.5 kg
Curb weight: Front	119 kg (Ca) 119.5 kg
Rear	123 kg
Engine:	
Engine oil: Grade	SE or SF class

Index

- Additional Considerations for Racing 256, 328
 Air Cleaner 148
 Air Cleaner Element 45, 312, 366
 Air Suction Valve 52, 295, 351
 Air Valve (Tire) 196
 Alternator Rotor 71, 351
 Alternator Startor 70
 Axle 196

 Ball Bearing (Engine) 190
 Battery 218
 Bolts, Nuts, Fasteners 382
 Brake 24, 118, 200, 293
 Brake Caliper 119
 Brake Disc 115
 Brake Hose 126
 Brake Light Switch 25
 Brake Master Cylinder 122, 124
 Brake Pad 118
 Breather Cover 64

 Caliper (brake) 119
 Camshaft 53, 157, 304
 Camshaft Chain 103, 159
 Camshaft Chain Guide 62, 159
 Camshaft Chain Tensioner 52, 159, 273, 275
 Camshaft Sprocket 56
 Carburetor 15, 45, 150, 299, 310, 312, 366
 Charging System 220, 370
 Clutch 17, 74, 177, 291, 346, 351
 Clutch Cable 127
 Clutch Release 65, 295, 351
 Connecting Rod 104, 172, 298, 310, 351
 Crankcase Split 89
 Crankshaft 103, 172
 Cylinder Block 60, 168
 Cylinder Head 57, 160, 275, 318
 Cylinder Head Studs 351
 Cylinder Head Valve 58, 161, 275

 Disc Brake 24, 118, 200, 293, 353, 366
 Drive Chain 23, 145, 197, 347

 Electric Starter System 232, 311, 375, 409
 Engine Lubrication 186
 Engine Oil 18
 Engine Oil Pump 77
 Engine Performance Curves 8
 Engine Removal 86, 305
 Engine Sprocket 66
 Engine Sprocket Cover 65
 External Shift Mechanism 67

 Flow Chart
 Disassembly — Chassis 108
 Disassembly — Engine Installed 42
 Engine Removal 84
 Front and Rear Suspension Setting 23
 Front Brake Light Switch 135, 306
 Front Fork 22, 140, 209, 292,
 307, 318, 346, 354, 366
 Front Wheel 109
 Fuel Gauge 378
 Fuel Level Sensor 43, 273, 299
 Fuel System 19, 291
 Fuel Tank 43, 149, 273
 Fuel Tap 43, 149

 General Lubrication 29, 381
 Grease Seal 196

 Headlight System 376
 Handlebars 136, 306, 353, 354, 409
 Handlebar Holder 306
 Headlight 28
 Headlight Unit 129
 Horn 247

 Ignition Coil 51
 Ignition Switch 134, 237
 Ignition System 225, 371, 409
 Indicator Light 132, 134
 Introduction to Disassembly 34

 Junction Box 357, 369

 Kawasaki Clean Air System 166

 LCD Fuel Gauge and Warner Unit 323, 378
 Lighting System 238, 276, 312
 Low Fuel Warning System 248, 278, 312
 List of Abbreviations 336

 Master Cylinder (Brake) 122, 124
 Meter Light 133, 134
 Model Identification 4, 269, 287, 338, 390, 412
 Muffler 50, 190, 302

 Needle Bearing (Engine) 190
 Neutral Switch 68, 238

 Oil Cooler 304
 Oil Filter 76
 Oil Filter Bypass Valve 76
 Oil Pan 77
 Oil Passage Plug 304
 Oil Pressure Relief Valve 77
 Oil Pressure Switch 74, 351
 Oil Pump (Engine) 77
 Oil Seal 190

 Pad (Brake) 118

414 INDEX

- Pick-up Coil Assembly 72
- Piston 62, 168, 318
- Piston Ring 62, 318
- Primary Chain. 103, 177

- Quick Reference Guide. 3

- Rear Brake Light Switch. 135
- Rear Shock Absorber 22, 143, 213, 273, 291,
310, 346, 356, 368
- Rear Sprocket. 114
- Rear Wheel. 110, 351
- Rear Wheel Coupling 114, 197
- Reservoir (Rear Master Cylinder) 126
- Rim 195
- Running Performance Curves. 9

- Safety Awareness 336
- Secondary Shaft 78, 176
- Service Data 358, 399
- Shift Pedal Linkage 19
- Silencer. 51
- Spark Plug 12, 410
- Special Tools 258, 279, 328, 383
- Specifications. 6, 270, 288, 339, 342, 392, 412
- Speedometer 133, 249
- Speedometer Cable 126
- Speedometer Gear Housing 111, 197
- Sprocket 199, 318
- Starter Lockout Switch 136
- Starter Motor 69, 295
- Starter Motor Clutch 78
- Starter Motor Idle Gear 82
- Steering. 26, 293
- Steering Stem. 138, 208, 309, 318
- Steering Stem Bearing 139, 309
- Supplement 267
 - Supplement — 1981 Model 268
 - Supplement — 1982 Model 285
 - Supplement — 1983 Model 335
 - Supplement — 1984 Model 389
 - Supplement — 1985, 1988 Models 411
- Swing Arm 143, 214, 275, 299, 356, 368

- Tachometer 133, 249, 378
- Tachometer Cable 128
- Tacho/Voltmeter. 319
- Tail/Brake Light 132
- Throttle Cable 14, 127, 298
- Throttle Grip 291
- Timing Advancer. 73
- Tire 116, 192
- Torque and Locking Agent 35, 273, 294, 350, 400
- Transmission 98, 180, 297, 310, 351
- Troubleshooting — Guide 251
- Turn Signal Assembly. 130, 306
- Turn Signal Light 130
- Turn Signal/Running Position Light 130

- Unit Conversion Table 337
- Uni-Trak Links 356, 368

- Valve Clearance. 12
- Valve Guide (Cylinder Head). 58
- Voltmeter 134, 249

- Wheel 109, 192, 275
- Wheel Balance. 27, 292, 348
- Wheel Bearing. 115, 197
- Wiring Diagram 263, 280, 329, 384, 404

MODEL APPLICATION

Year	Model	Beginning Frame No.
1980	KZ/Z750-E1	KZ750E-000001
	KZ/Z750-H1	KZ750H-000001
1981	KZ750-E2	KZ750E-012001 or JKAKZDE1□BA013722
	KZ/Z750-H2	KZ750H-013501 or JKAKZDH1□BA017121
	Z750-L1	KZ750E-012001
1982	KZ750-E3	JKAKZDE1□CA032401
	KZ/Z750-H3	KZ750H-031601 or JKAKZDH1□CA031601
	Z750-L2	KZ750E-032401
	KZ/Z750-R1	KZ750R-000001 or JKAKZDR1□CA000001
1983	KZ750-H4	JKAKZDH1□DA039501
	KZ/Z750-L3	KZ750R-014501 or JKAKZDL1□DA014501
	ZX750-A1	ZX750A-000001 or JKAZXDA1□DA000001
1984	KZ700-A1	JKAKZ6A1□EA000001
	KZ/Z750-L4	KZ750R-017201 or JKAKZDL1□EA017201
	ZX750-A2	ZX750A-018001 or JKAZXDA1□EA018001 or JKAZXDA1□EB500001
1985	ZX750-A3	ZX750A-025501 or JKAZXDA1□FA025501 or JKAZXDA1□FB504101
1988	ZX750-A5	ZX750A-028714

□ : The digit in this position changes from one machine to another.



KAWASAKI HEAVY INDUSTRIES, LTD.
Consumer Products & Machinery Group